

POWER VENTER SYSTEM

MODEL: PVO-300, PVO-600



Included is one ETL and cETL listed Power Venter to be used primarily with a single 120VAC controlled oil fired furnace, boiler, or water heater. The PVO may be used to common vent multiple appliances with the addition of a Control Kit. Please consult Field Control's Technical Support for other options.

TYPICAL VENTING SYSTEM COMPONENTS

One PVO Series Power Venter with pre-wired controls; adjustable post purge relay timer, adjustable draft proving switch, direct access terminal blocks, and piping tee for multiple appliance systems.

- Side Wall Vent Hood (Not included)
- Spill Switches (Not included)
- CK-Series Control Kit for multiple appliance venting (Not Included)

READ THESE INSTRUCTIONS CAREFULLY AND COMPLETELY BEFORE PROCEEDING WITH THE INSTALLATION.

This device **MUST** be installed by a qualified agency in accordance with the manufacturer's installation instructions. The definition of a qualified agency is: any individual, firm, corporation or company which either in person or through a representative is engaged in, and is responsible for, the installation and operation of HVAC appliances, who is experienced in such work, familiar with all the precautions required, and has complied with all the requirements of the authority having jurisdiction.

Please retain these instructions after installation.

Installed By: _____ Phone: _____ Installation Date: _____



FIELD CONTROLS

www.fieldcontrols.com

UNIT SPECIFICATIONS (See Table 1 and Figure 1)

Table 1

UNIT DIMENSIONS (INCHES)				
MODEL	H	W	D	I/O*
PVO-300	7.50	9.25	7.00	4/4
PVO-600	8.75	9.75	8.50	4/4

*Inlet and outlet diameter.

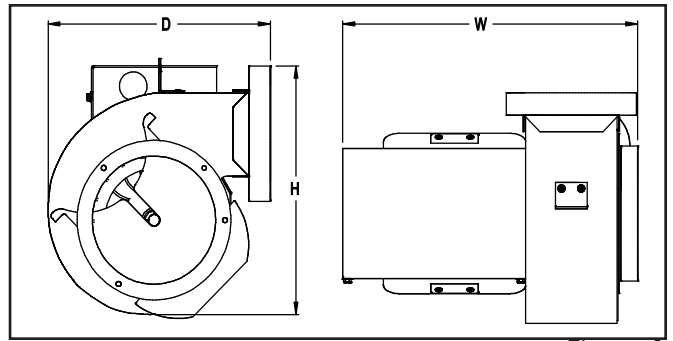

Figure 1

ELECTRICAL RATINGS						
MODEL	VAC	Hz	RPM	WATT	AMP	TP**
PVO-300	120	60	3000	145	2.1	YES
PVO-600	120	60	3000	167	1.5	YES

**Thermally protected motor.

SIDEWALL VENT HOODS (Model SWH-1)

The vent hood should be chosen that matches the outlet size of the Power Venter. (See Figure 2)

NOTE: When using different sizes consider reducers and specific size pipe when determining equivalent length of vent pipe. Sidewall vent hoods are available in the following sizes:

- SWH-1-3 - 3"
- SWH-1-4 - 4"
- SWH-1-5 - 5"
- SWH-1-6 - 6"
- SWH-1-8 - 8"

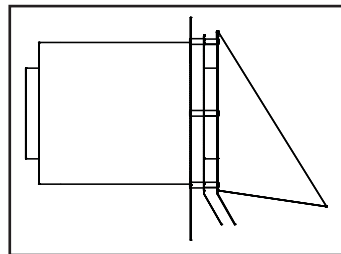

Figure 2

CONTROL KITS

The following Control Kits can be used to common vent multiple appliances with one PVO unit:

CK-61:	For operation with all 120VAC oil-fired systems. Includes draft proving switch, adjustable electronic post purge timer, RJR isolation relay, and WMO-1 secondary safety switch.
CK-62:	Same as CK-61, except has thermally activated post purge.
CK-63:	For operation with all 120VAC oil-fired systems. Includes draft proving switch, adjustable electronic post purge timer, and WMO-1 secondary safety switch.

SYSTEM OPERATION

1. The thermostat (wall thermostat, or aquastat) calls for heat and energizes a relay which activates the power venter. After the venter motor has come up to speed, the pressure switch closes. This completes the circuit to the burner and allows the burner to fire.
2. After the heating requirement has been satisfied, the thermostat circuit will open and de-activate the burner and power venter circuit.
3. The power venter continues to operate for a period of time after the burner has shut off to purge remaining flue gases.

POWER VENTER SIZING

In order to choose the correct size power venter for a particular installation, the total input firing rate and total equivalent length of vent pipe to be used must be known. Refer to Table 2 to determine the maximum allowable equivalent feet of pipe for each model used with the pipe diameters shown. When venting multiple appliances, add the input of each appliance to determine the total input. Always choose a power venter that is capable of handling more than the system requires. The choke plate can be adjusted to compensate for the difference.

Table 2

MAXIMUM EQUIVALENT HORIZONTAL PIPE LENGTH (FEET)						
BTU/HR INPUT	VENTER MODEL NO. AND VENT PIPE DIAMETER					
	PVO-300			PVO-600		
	4"	5"	6"	5"	6"	8"
0.75	287	---	---	---	---	---
1.00	150	257	346	428	---	---
1.50	75	120	172	212	---	---
2.25	---	51	70	86	143	211
3.00	---	---	---	46	74	116
3.75	---	---	---	---	51	84
4.00	---	---	---	---	---	77

PROCEDURE FOR CALCULATING TOTAL EQUIVALENT PIPE LENGTH IN FEET

1. Calculate the total equivalent feet for each type of fitting used in the venting system from the following chart.
2. Calculate the total amount of feet for the straight lengths of vent pipe.
3. Add the equivalent feet for the fittings with the total amount of feet of straight lengths.

Table 3

EQUIVALENT LENGTH (FEET) OF VENT PIPE FOR VENT PIPE FITTINGS									
VENT PIPE FITTINGS		VENT PIPE DIAMETER							
		3"	4"	5"	6"	7"	8"	9"	10"
TEE		19	25	31	38	44	50	56	63
90° ELBOW		5	7	9	11	12	14	16	18
45° ELBOW		3	4	4	5	6	7	8	9
REDUCER (d/D)*	1/4	8	11	14	17	19	22	25	28
	1/2	5	7	8	10	12	13	15	17
	3/4	2	3	3	4	4	5	6	6

*Reducer or increaser ratio (d/D) small diameter divided by the larger diameter. (See Figure 3)

Example: 4" to 8" reducer, the reducer ratio is $d/D = \frac{4}{8} = \frac{1}{2}$. To estimate the equivalent foot length for the fitting, use the smaller pipe diameter for the equivalent length figure. Example: 4" to 8" reducer; the reducer ratio is $\frac{1}{2}$ and the smaller pipe diameter is 4". So, from the chart, the equivalent feet would be 7 feet.

Example: System Pipe Size = 4"

Step 1 2 - 90° Elbows (4") = 14 Ft.

Step 2 10 - 2 Ft. Lengths of 4" Pipe = 20 Ft.

Step 3 Total Equivalent Feet = 14 Ft. + 20 Ft. = 34 Ft.

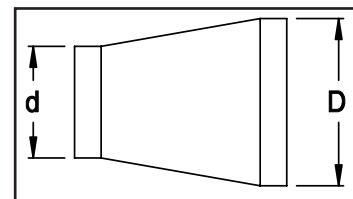

Figure 3

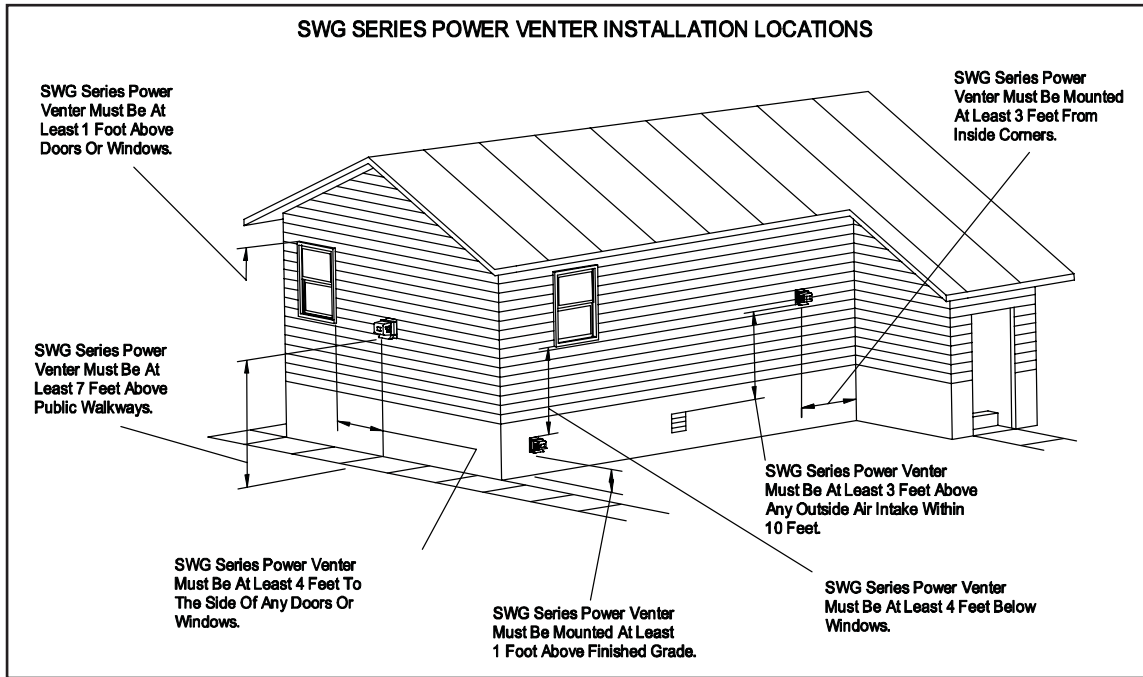

Diagram A

INSTALLATION SAFETY INSTRUCTIONS

CAUTION: This device must be installed by a qualified installer in accordance with the manufacturer's installation instructions. Appliances should have a minimum of 75% combustion efficiency or have a maximum measured flue gas temperature of 550°F at the inlet of the venter.

1. The power venting system must be installed by a qualified installer. "Qualified Installer" shall mean an individual who has been properly trained or a licensed installer. The installer must write or imprint his name, phone number and date of installation on the installation tag. The tag should be attached to the power venter unit. Recording burner and venting system initial operational information is recommended as a guide for service or burner tune-up. Enter this information in the Venting System Operational Information Chart.
2. Safety inspection of a venting system should be performed before and after installing a power venting system on an existing or new appliance. Procedures to follow are those recommended by the National Fuel Gas Code, ANSI Z223.1 or refer to the "General Installation Inspection" section of this manual.
3. Plan the vent system layout before installation to avoid the possibility of accidental contact with concealed wiring or plumbing inside walls.
4. Single wall vent pipe may be used to join an appliance to the venting system, but if proper clearances cannot be maintained from combustibles materials, Class B Vent Pipe should be used for gas appliances. Refer to national or local codes for guidelines.
5. Disconnect power supply before making wiring connections to prevent electrical shock and equipment damage.
6. This equipment is designed to overcome minor negative pressure conditions. To ensure extreme negative pressure does not exist, follow the "General Installation Inspection" section of this manual.
7. Heating appliances equipped with draft hoods, such as boilers or furnaces, LP and natural gas appliances SHOULD have a secondary spillage switch installed. On appliances without draft hoods, it is recommended that the secondary safety switch GSK-3 be installed into the system. Gas-fired 30 millivolt power systems MUST be equipped with a spillage switch.
8. Air flow adjustment MUST be made to ensure appliance efficiency. This should be done at the appliance exhaust outlet with a velocity meter, draft gauge or by the "match test procedure." The match test is in accordance with National Fuel Gas Code ANSI Z223.1, Section 8.6.
9. On heating appliances not equipped with a draft hood, a barometric draft control MUST be installed to regulate proper air flow and fluctuations in the system's air flow during operation. Fluctuations can come from wind loads on the outlet of the venter, house depressurization during windy days, and the different house ventilation requirements between summer and winter operation. Use a Field Controls Type MG-1 Barometric Draft Control. Gas-fired draft induced systems should have a single-acting or double-acting barometric draft control installed.

INSTALLATION OF POWER VENTER

CAUTION: Failure to install, maintain and/or operate the power venting system in accordance with manufacturer's instructions will result in conditions which may produce bodily injury and/or property damage.

1. Remove power venter from box and inspect unit for damage. If the carton has been crushed or mutilated, check unit very carefully for damage. Rotate venter wheel to ensure that the motor and venter wheel rotate freely. DO NOT install if any damage is apparent. Refer to unit sizing chart to check proper venter sizing.
2. Location of the termination of the venting system should be installed in accordance with the National Fuel Gas Code, ANSI Z233.1, manufacturer's recommendations, and/or local codes which are applicable. See the following requirements or refer to Diagram A for typical locations.
 - a. The exit termination of mechanical draft systems shall not be less than 7' above grade when located adjacent to public walkways.
 - b. A venting system shall terminate at least 3' above any forced air inlet located within 10'.
 - c. The venting system of other than a direct vent appliance shall terminate at least 4' below, 4' horizontally from, or 1' above any door, window, or gravity air inlet into the building. When venting oil fired equipment with a Field Controls CAS-2 series Airboot® kit, the intake air hood can be mounted within 12" of the power venter exhaust.
 - d. The vent termination of a direct vent appliance with an input of 50,000 BTU/Hr or less, shall be located at least 9" from any opening through which vented gases could enter the building. With an input over 50,000 BTU/Hr, a 12" termination clearance shall be required.
 - e. The vent termination point shall not be installed closer than 3' from an inside corner of an L-shaped structure.
 - f. The vent termination should not be mounted directly above or within 3' horizontally from an oil tank vent or gas meter.
 - g. The bottom of the vent terminal shall be located at least 12" above finished grade.

CONNECTING VENTER TO APPLIANCE

The venting system should be installed and supported in accordance with the National Fuel Gas Code ANSI Z233.1, or in accordance with any local codes. A vent pipe connector shall be supported for the design and weight of the material employed, to maintain clearances, prevent physical damage and separation of joints. A vent pipe increaser or reducer may be required for connecting the venter to the vent system. Smaller vent pipe sizes than a chimney-vented system may be used for the vent system.

Route the vent pipe from the appliance to the venter using as few elbows as possible. The horizontal section of the vent pipe should have a slight upward slope from the appliance to the venter. For clearances to combustible materials, multiple appliance venting and other installation requirements, refer to the National Fuel Gas Code ANSI Z223.1, and/or any applicable local codes or appliance manufacturer's installation instructions.

GENERAL WIRING INSTRUCTIONS

CAUTION: Disconnect electrical power before wiring power venter!

The PVO is designed to be used with appliances with 120VAC control systems. Wire the venter motor and controls in accordance with the National Electrical Code, and/or applicable local codes. UNIT MUST BE GROUNDED. Check ground circuit to make certain that the unit has been properly grounded. The wiring should be protected by an over-current circuit device rated at 15 amperes. CAUTION MUST be taken to ensure that the wiring does not come in contact with any heat source. All line voltage and safety control circuits between the venter and appliance MUST be wired in accordance with the National Electrical Code for Class 1 wiring, or equivalent methods. Refer to wiring diagrams B & C for typical wiring. For other wiring diagrams, please contact Field Controls Technical Support.

NOTE: When applying power to the PVO for the first time, the venter motor may or may not run for up to 10 minutes. This is normal, and will not affect the operation of the system.

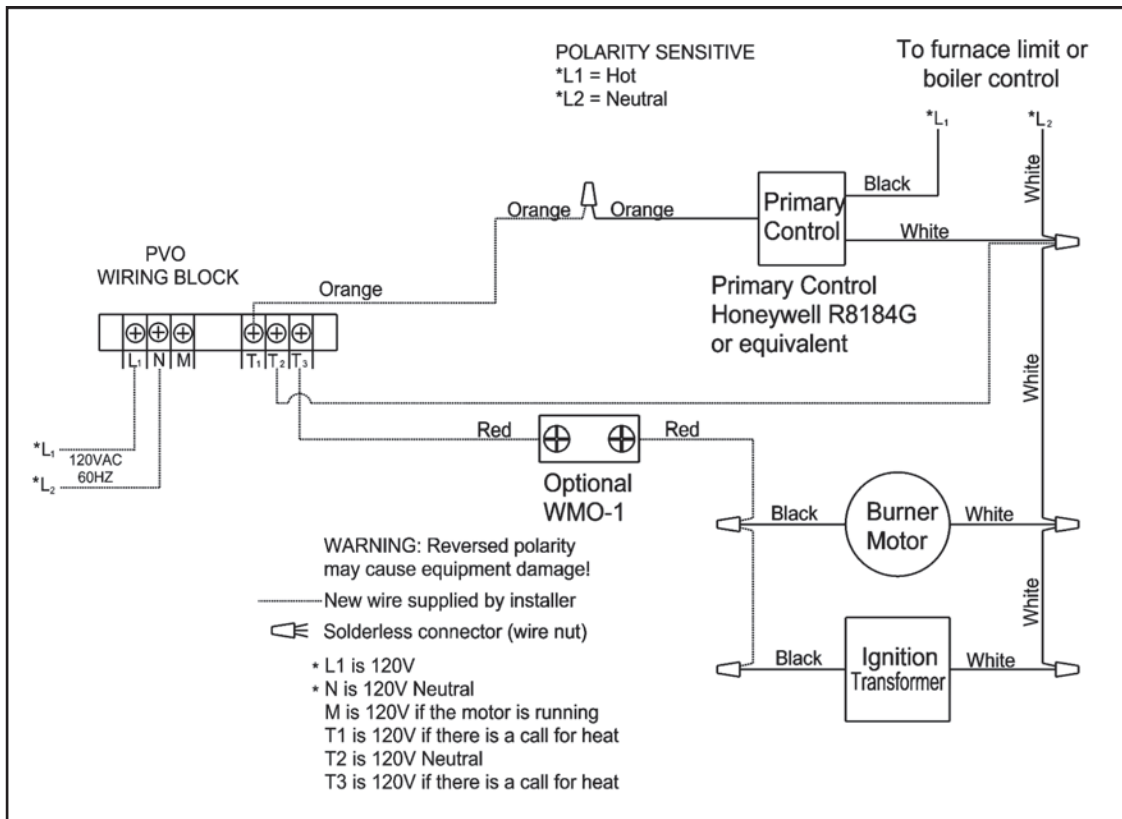

Diagram B

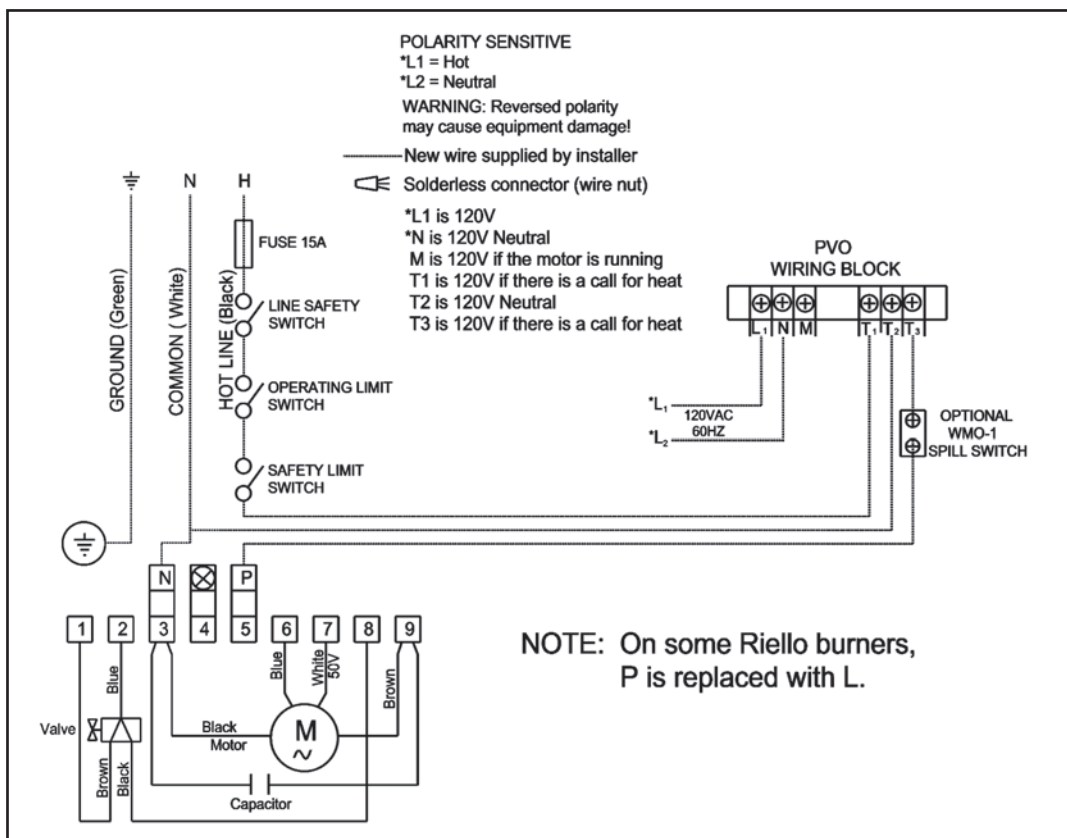

Diagram C

MULTIPLE APPLIANCE SYSTEMS

When using one PVO power venter to common vent more than one appliance, a Control Kit is required for each additional appliance.

1. Connect the negative pressure port of each air pressure fan proving switch on all Control Kits being used to the provided tee mounted on the PVO. (See Figure 4)
2. Remove the cap from the branch of the tee and use the ferrule and compression nut provided in the small envelope with the PVO to attach the connecting tube.
3. Refer to the instruction sheet included with each Control Kit for specific instructions for that kit, including wiring diagrams.

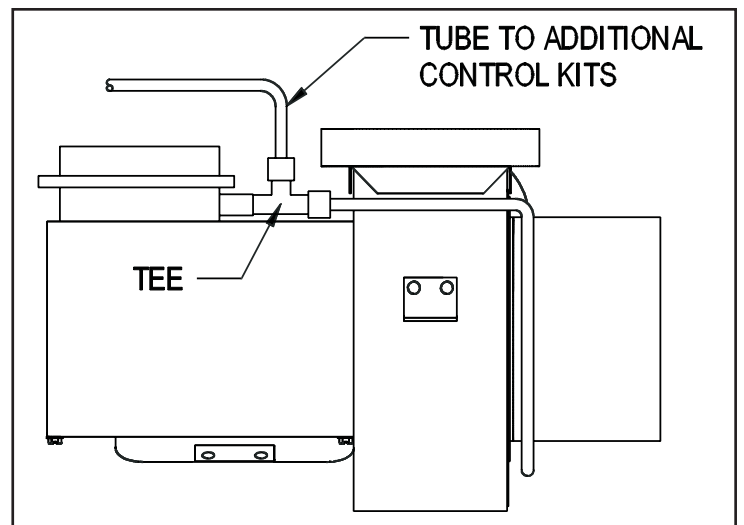

Figure 4

AIR FLOW ADJUSTMENT

NOTE: Before installing, refer to the General Installation Inspection to check for negative pressure problems in the building.

1. To adjust the power venter air flow, open the choke plate $\frac{1}{2}$ to $\frac{3}{4}$ of the way open. (See Figure 5) Follow the appliance manufacturer's procedures for starting the heating appliance.
2. Adjust the thermostat to call for "Heat." After the system has operated for several minutes to stabilize flue gas temperatures, use a draft gauge, velocity meter, or match test procedure to check for negative draft or up-draft at the heating appliance outlet or air flow into the draft hood.
3. Adjust the inlet choke damper on the power venter in or out to obtain the minimum air flow required to maintain draft. Then increase air flow slightly (10% over minimum air flow rate) to ensure proper venting. For power burners, adjust draft to proper over-fired draft. If using a barometric draft control, use the draft control to fine tune the system draft.
4. If proper draft has been established, secure the choke plate by tightening the screws on the inlet collar.
5. Shut off thermostat and check for residual heat spilling from the draft hood or draft control. If this occurs, increase the post purge time on the timer.

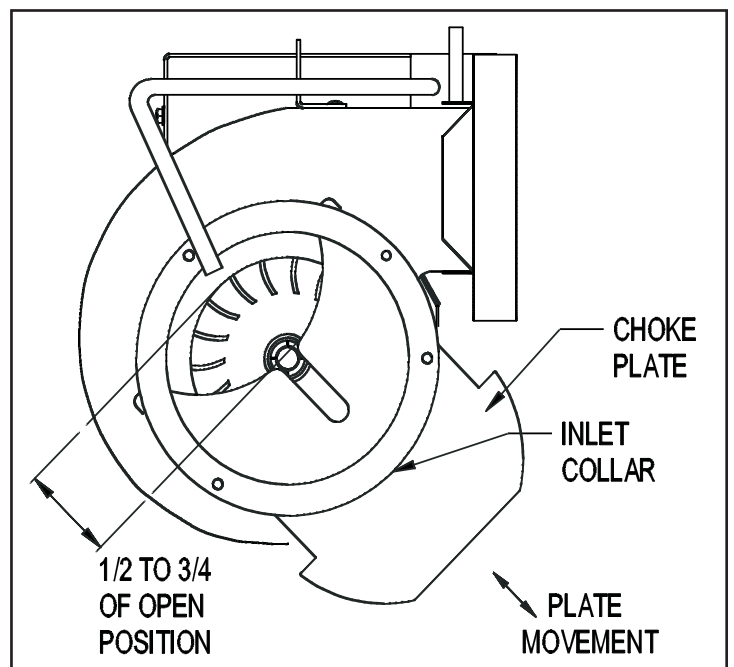

Figure 5

NOTE: After proper venting has been established, it is recommended that a combustion test and a smoke test be performed to ensure maximum burner efficiency. Oil burner air adjustments should be set at a zero to a trace smoke at the highest or recommended CO₂% setting set by heating equipment manufacturer.

PRESSURE SWITCH ADJUSTMENT

1. With the vent air flow set and the appliance operating at the best operating efficiency, adjust the pressure switch by rotating the adjustment screw clockwise until the burner shuts off.
2. Rotate the adjustment screw counterclockwise until the burner fires.
3. Rotate the adjustment screw an additional $\frac{1}{4}$ turn counterclockwise to ensure proper switch setting. (See Figure 6)

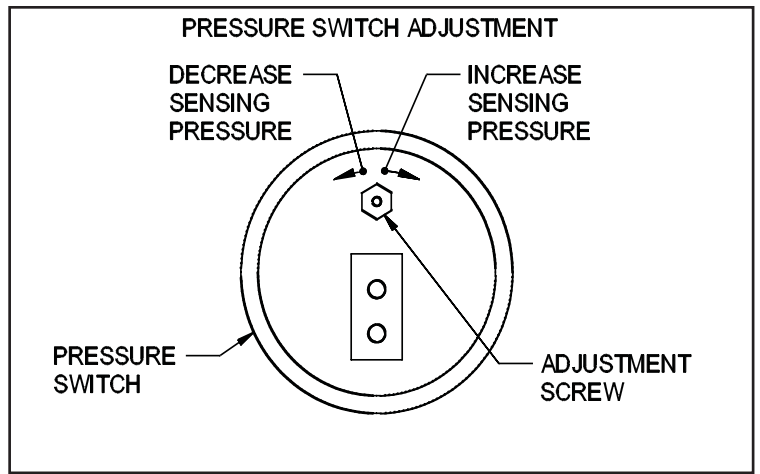

Figure 6

POST PURGE TIMER ADJUSTMENT

To adjust the post purge time, refer to Figures 7 & 8.

For timer that looks like Figure 7: Rotate the timer adjustment on the timer clockwise to increase the operation time. To decrease the operation time, rotate the timer adjustment counterclockwise.

For timer that looks like Figure 8: Rotate the timer adjustment on the timer counterclockwise to increase the operation time. To decrease the operation time, rotate the timer adjustment clockwise.

*Typical post purge time should be between 3 to 5 minutes.

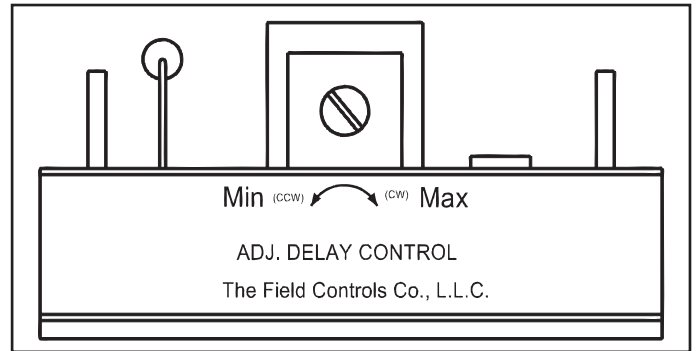

Figure 7

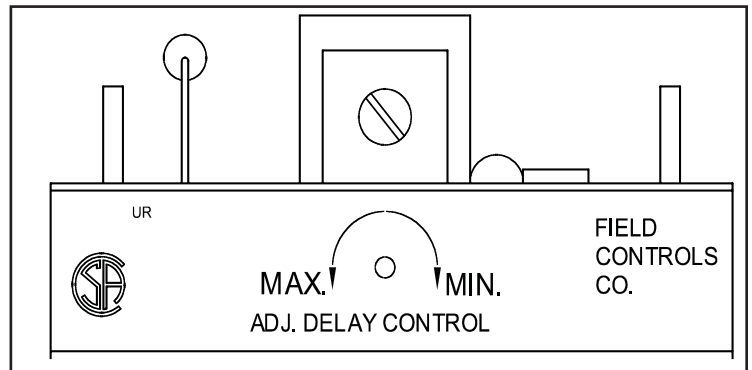

Figure 8

GENERAL INSTALLATION INSPECTION

Follow recommended procedures for safety inspection of a heating appliance in accordance with the National Fuel Gas Code ANSI Z223.1. The following procedure will help in evaluation of the venting system. It is intended as a guide to aid in determining that the appliance is properly installed and is in a safe condition for continuous use. This is a generalized procedure which cannot anticipate all situations. Accordingly, in some cases deviation from this procedure may be necessary to determine safe operation of the equipment. If it is determined that a condition which could result in unsafe operation exists, the appliance should be shut off and the owner advised of the unsafe conditions. Corrections must be made prior to allowing continuous operation. The following steps should be taken in making a safety inspection.

1. Visually inspect the venting system for proper size and determine that there is no blockage, restriction, leakage, corrosion, or other deficiencies which could cause unsafe operation.
2. To the extent possible, close all building doors, windows, and all doors to the room in which the heating appliance is located. Turn on clothes dryers and any exhaust fans so that they operate at maximum speed. Do not operate a summer exhaust fan. Also close all fireplace dampers. If after completing steps 3 through 7 it is believed that sufficient combustion air is not available, refer to the National Fuel Gas Code ANSI Z223.1 or any local codes for proper guidelines.
3. Place the appliance being inspected into operation. Follow the lighting instructions and adjust the thermostat so that the heating appliance will operate continuously.
4. Determine that the burner is operating properly and that the main burner ignition functions satisfactorily, by interrupting the electrical power of the appliance in any safely convenient manner. Test the burner safety device to determine if it is operating properly by extinguishing the pilot or disconnecting the flame safety circuit.
5. Visually determine that the main burner is burning properly, i.e. no floating, lifting, or flashbacks. Adjust the primary air shutter as required by the appliance manufacturer. If the appliance is equipped with high and low flame control or flame modulation, check for proper main burner operation at both flame levels.
6. If appliances are equipped with high and low flame control or flame modulation, check for proper main burner operation at low flame.
7. Test for exhaust gas spillage at the draft hood or the barometric draft control after approximately 5 minutes of main burner operation. Use a draft meter, or flame or smoke from a match, candle, or cigarette. If spillage occurs, adequate air is not available. Shut off heating appliance thermostat and check for spillage around the draft hood, barometric draft control, or burner inlet air location after power venter has stopped operation. If a flow reversal is noticed, house depressurization is occurring and make up air is required. For oil-fired systems, this may be noticed by oil fume smell after post purge cycle.
8. Turn on all fuel burning appliances within the same room so that they operate at their maximum capacity. Then repeat Steps 5 and 7.
9. Return all doors, windows, exhaust fans, fireplace dampers, and any other fuel burning appliances to their previous condition.

MAINTENANCE

1. **Motor:** Inspect the motor once a year - motor should rotate freely. To prolong the life of the PVO-600 motor, it must be lubricated with six drops of SWG Superlube, Part #46226200, annually. The PVO-300 has sealed ball bearings, and therefore does not need to be oiled.
2. **Blower Wheel:** Inspect the blower wheel annually to clear any soot, ash, or coating which inhibits either rotation or air flow. Remove all foreign materials before operating.
3. **Vent System:** Inspect all vent connections annually for looseness, for evidence of corrosion, and for flue gas leakage. Replace, seal, or tighten pipe connections if necessary. Check the power venter choke plate to ensure it is secured in place. Check the barometric draft control, if installed, to ensure the gate swings freely.
4. **System Safety Devices:** With the heating system operating, disconnect the pressure sensing tube from the pressure switch on the venter. This should stop the burner operation. Re-connecting the tube will relight the burner.

PV SERIES POWER VENTER: VERTICAL VENTING OPTION

Diagram D illustrates correct and incorrect installation of PV series venter in vertical vent configuration (except PVE-1200). The correct installation maintains the required vertical position of the pressure switch; the incorrect installation does not. The following conditions must also be observed:

- Natural gas, LP gas or #2 fuel oil appliance rated at 75% or greater non-condensing type of appliance.
- Maximum input temperature at power venter: 575°F

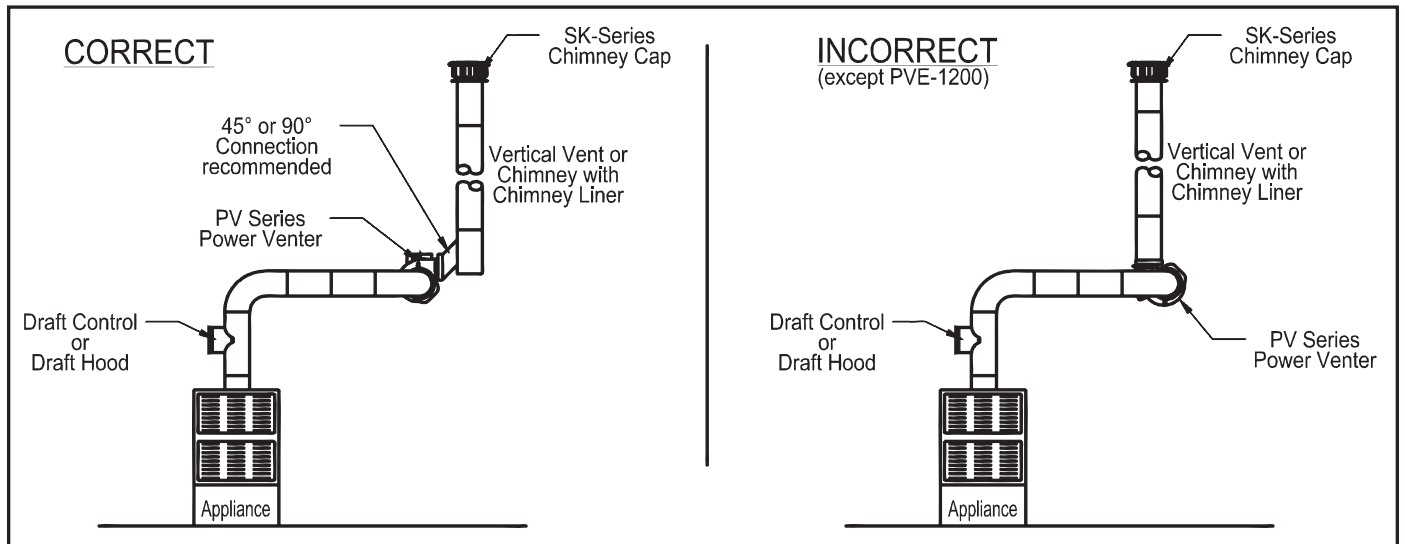

Diagram D

REPLACEMENT PARTS LIST

The following items are available for replacement, if necessary.

REPLACEMENT PARTS LIST		
DESCRIPTION	PVO-300	PVO-600
Motor	46032000	46083300
Blower Wheel	46033400	46089400
Post Purge Relay Timer	46144700	46144700
Pressure Switch	46311000	46311000

VENTING SYSTEM OPERATIONAL INFORMATION

Date:							
Oil Burner Nozzle Size							
Oil Burner Operating Pressure							
Pump Operating Vacuum Pressure							
Smoke Number							
Over-Fire Draft							
Equipment Outlet Flue Gas Temperature							
CO ₂ measurement							

LIMITED WARRANTY

Field Controls, LLC ("Company") warrants that its products shall be free from defects in material and workmanship under normal use for the limited period indicated, **from the date of manufacture, subject to the provisions 1-8 below.**

Eighteen (18) months

All Field Controls Products (except for those listed below as 5 years or 90 days).

Five (5) years

Field Controls Direct Vent Systems (FDVS), Field Oil Vent Kits (FOVP), and ComboVents (CV).

Field Controls warrants that the products listed below shall be free from defects in material and workmanship under normal use for the limited period indicated, **from the date of purchase by the consumer, subject to the provisions 1-8 below.**

Ninety (90) days

UV lamps/bulbs

Provisions:

1. During the limited warranty period, Company, or its authorized service representative, will repair or replace, at Company's option, without charge, a defective Product. Product that is repaired may be repaired with new or refurbished replacement parts. Product that is replaced may be replaced with a new or refurbished product of the same or similar design. Company will return repaired or replacement Product to customer in working condition. Labor charges are not covered as part of the limited warranty.
2. With regard to UV lamps/bulbs, customer shall be required to include a "valid proof of purchase" (sales receipt) identifying the Product purchased (Product model or accurate date code information) and the date the Product(s) was purchased.
3. Product whose warranty/quality stickers, Product serial number plates or electronic serial numbers have been removed, altered or rendered illegible shall not be covered under the limited warranty.
4. Defective Product must be returned to Company, postage prepaid.
5. IN NO EVENT SHALL COMPANY BE LIABLE FOR ANY INDIRECT, SPECIAL, INCIDENTAL, CONSEQUENTIAL, OR SIMILAR DAMAGES (INCLUDING, BUT NOT LIMITED TO, LOST PROFITS OR REVENUE, INABILITY TO USE PRODUCT, OR OTHER ASSOCIATED EQUIPMENT, THE COST OF SUBSTITUTE EQUIPMENT, AND CLAIMS BY THIRD PARTIES) RESULTING FROM THE USE OF PRODUCT. Some states do not allow the exclusion or limitation of incidental or consequential damages, so the above limitation or exclusion may not apply to you.
6. THIS WARRANTY AND REMEDIES ARE EXCLUSIVE AND IN LIEU OF ALL OTHER WARRANTIES, REMEDIES AND CONDITIONS, WHETHER ORAL, WRITTEN, EXPRESS, STATUTORY OR IMPLIED. TO THE EXTENT PERMITTED BY LAW, COMPANY DISCLAIMS ALL IMPLIED AND STATUTORY WARRANTIES, INCLUDING WARRANTIES OF MERCHANTABILITY AND FITNESS FOR A PARTICULAR PURPOSE.
7. Company makes no warranty of any kind in regard to other manufacturer's products distributed by Company. Company will pass on all warranties made by the manufacturer and where possible, will expedite the claim on behalf of the customer, but ultimately, responsibility for disposition of the warranty claim lies with the manufacturer.
8. Product that has been subjected to misuse, accident, shipping or other physical damage, improper installation or application, abnormal operation or handling, neglect, fire, water or other liquid intrusion are not covered by the warranty.



FIELD CONTROLS

Phone: 252.522.3031 • Fax: 252.522.0214
www.fieldcontrols.com