

DU-ALL DUAL DRAIN WASHING MACHINE OUTLET BOX

INSTALLATION INSTRUCTIONS:

1. Before cementing drain line into washer box coupling, remove drain locator tape and place on top of knock-out test cap inside box over the coupling being plumbed. (See Figures A & B below)
2. Cement drain line and P-Trap assemblies.
3. Connect water supply lines.
4. Cement coupling plug into unplumbed drain coupling.*

* This precautionary step may be eliminated if drain line is tested and inspected for leaks, and test cap over plumbed drain coupling is knocked out, *PRIOR TO HANGING SHEETROCK. IT CAN ALSO BE ELIMINATED IF INSTALLED IN TOP MOUNT POSITION.*

** For top mounted valves simply invert box with valves positioned on top.

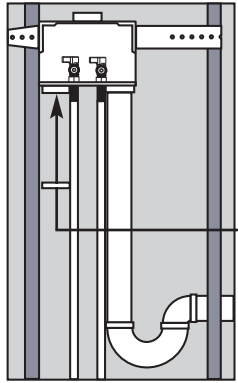

RIGHT HAND DRAIN

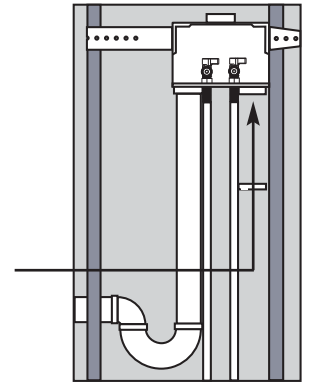

LEFT HAND DRAIN



IMPORTANT NOTICE FOR PROPER KNOCK-OUT

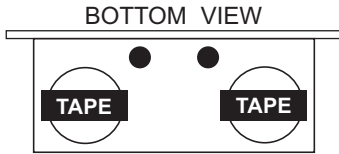

FIGURE A

Remove Tape from
Drain side to be
Plumbed.
See Figure A

Apply Tape Inside
Box over Knock-out
to be Plumbed.
See Figure B



FIGURE B

SEE REVERSE SIDE FOR KNOCKOUT INSTRUCTIONS

Manufacturers of **WELD-ON** and **WATER-TITE** Products

202 Industrial Park Lane, P.O. Box 220, Collierville, TN 38027 • TEL: (901) 853-5001 • FAX: (901) 853-5008

BB12175

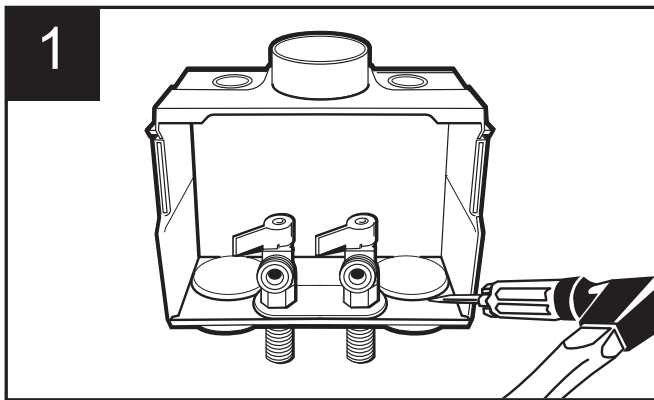

Position flathead screwdriver at intersection of bottom wall and raised test cap.

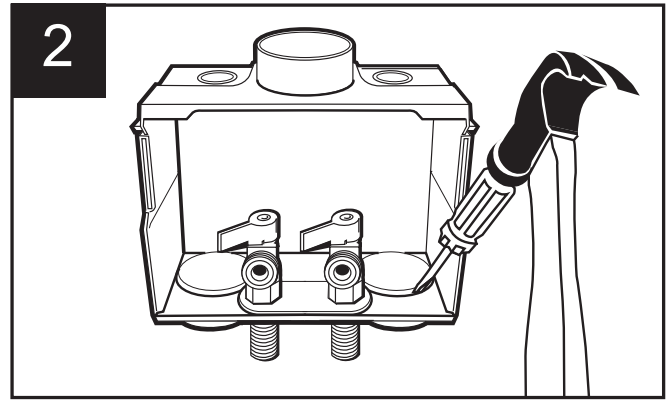

Hit screwdriver until it penetrates under test cap.

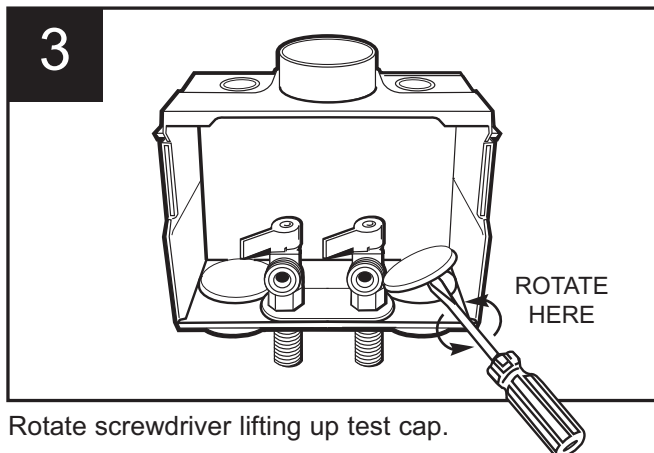

Rotate screwdriver lifting up test cap.

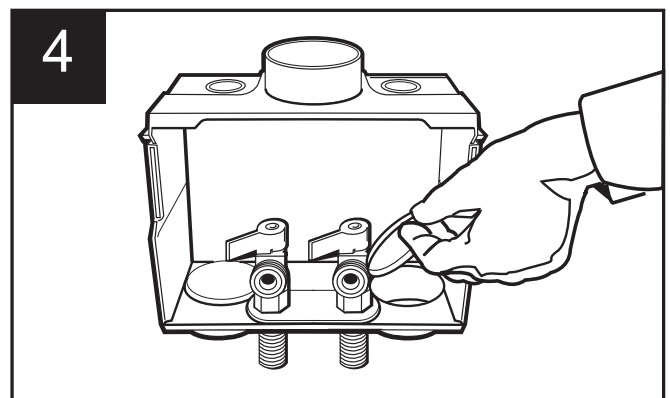

Reach in with hand or pliers and remove test cap.