

INSTALLATION, OPERATING AND SERVICE INSTRUCTIONS CL™ SERIES CAST IRON OIL-FIRED BOILER

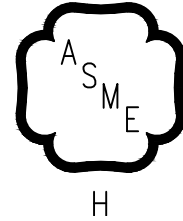

For service or repairs to boiler, call your heating contractor. When seeking information on boiler, provide Boiler Model Number and Serial Number as shown on Rating Label.

Boiler Model Number CL	Boiler Serial Number	Installation Date
Heating Contractor		Phone Number
Address		



IMPORTANT INFORMATION - READ CAREFULLY

All boilers must be installed in accordance with National, State and Local Plumbing, Heating and Electrical Codes and the regulations of the serving utilities. These Codes and Regulations may differ from this instruction manual. Authorities having jurisdiction should be consulted before installations are made.

In all cases, reference should be made to the following Standards:

USA BOILERS

- A. Current Edition of American National Standard ANSI/NFPA 31, “Installation of Oil Burning Equipment”, for recommended installation practices.
- B. Current Edition of American National Standard ANSI/NFPA 211, “Chimneys, Fireplaces, Vents, and Solid Fuel Burning Appliances”, For Venting requirements.
- C. Current Edition of American Society of Mechanical Engineers ASME CSD-1, “Controls and Safety Devices for Automatically Fired Boilers”, for assembly and operations of controls and safety devices.
- D. All wiring on boilers installed in the USA shall be made in accordance with the National Electrical Code and/or Local Regulations.

The following terms are used throughout this manual to bring attention to the presence of hazards of various risk levels, or to important information concerning product life.

DANGER

Indicates an imminently hazardous situation which, if not avoided, will result in death, serious injury or substantial property damage.

CAUTION

Indicates a potentially hazardous situation which, if not avoided, may result in moderate or minor injury or property damage.

WARNING

Indicates a potentially hazardous situation which, if not avoided, could result in death, serious injury or substantial property damage.

NOTICE

Indicates special instructions on installation, operation, or maintenance which are important but not related to personal injury hazards.

NOTICE

This boiler has a limited warranty, a copy of which is printed on the back of this manual. The warranty for this boiler is valid only if the boiler has been installed, maintained and operated in accordance with these instructions.

Surface rust on cast iron sections may be attributed to the manufacturing process as well as condensation during storage. Surface rust is normal and does not affect the performance or longevity of a boiler.

DANGER

DO NOT store or use gasoline or other flammable vapors or liquids in the vicinity of this or any other boiler.

WARNING

Improper installation, adjustment, alteration, service or maintenance can cause property damage, personal injury or loss of life. Failure to follow all instructions in the proper order can cause personal injury or death. Read and understand all instructions, including all those contained in component manufacturers manuals which are provided with the boiler before installing, starting-up, operating, maintaining or servicing this boiler. Keep this manual and literature in legible condition and posted near boiler for reference by owner and service technician.

This boiler requires regular maintenance and service to operate safely. Follow the instructions contained in this manual.

Installation, maintenance, and service must be performed only by an experienced, skilled and knowledgeable installer or service agency.

All heating systems should be designed by competent contractors and only persons knowledgeable in the layout and installation of hydronic heating systems should attempt installation of any boiler.

Installation is not complete unless a pressure relief valve is installed into the tapping located on top left corner of front section- Refer to Figures 1A thru 1C and Section III "Installation Instructions" for additional details.

It is the responsibility of the installing contractor to see that all controls are correctly installed and are operating properly when installation is complete including verifying that the limit sensor is fully installed (seated in bottom of Well).

Failure to properly install Limit Sensor may result in property damage, personal injury or loss of life due to elevated operating temperatures and/or pressures.

This boiler is suitable for installation on combustible flooring. **DO NOT** install boiler on carpeting.

DO NOT tamper with or alter the boiler or controls.

Inspect flueways at least once a year - preferably at the start of the heating season. The inside of the combustion chamber, the vent system and boiler flueways should be cleaned if soot or scale has accumulated.

When cleaning this boiler, **DO NOT** damage combustion chamber liner and/or rear target wall. If damaged, combustion chamber insulation must be replaced immediately.

Oil Burner and Controls must be checked at least once a year or as may be necessitated.

DO NOT operate boiler with jumpered or absent controls or safety devices.

DO NOT operate boiler if any control, switch, component, or device has been subject to water.

Boiler materials of construction, products of combustion and the fuel contain alumina, silica, heavy metals, carbon monoxide, nitrogen oxides, aldehydes and/or other toxic or harmful substances which can cause death or serious injury and which are known to the state of California to cause cancer, birth defects and other reproductive harm. Always use proper safety clothing, respirators and equipment when servicing or working nearby the boiler.

WARNING

This boiler contains very hot water under 12 - 15 PSI pressure. **DO NOT** unscrew any pipe fittings nor attempt to disconnect any components of this boiler without positively assuring the water is cool and has no pressure. Always wear protective clothing and equipment when installing, starting up or servicing this boiler to prevent scald injuries. **DO NOT** rely on the pressure and temperature gauges to determine the temperature and pressure of the boiler. This boiler contains components which become very hot when the boiler is operating. **DO NOT** touch any components unless they are cool.

High water temperatures increase the risk of scalding injury. If this boiler is equipped with a tankless heater for domestic water supply, a flow regulator and automatic mixing valve must be installed properly in tankless heater piping. Refer to Section III "Installation Instructions" for additional details.

This boiler needs fresh air for safe operation and must be installed so there are provisions for adequate combustion and ventilation air.

This boiler must be connected to an approved chimney or vent system in good condition. Serious property damage could result if the boiler is connected to a dirty or inadequate chimney or vent system. The interior of the chimney flue must be inspected and cleaned before the start of the heating season for any obstructions. A clean and unobstructed chimney flue is necessary to allow noxious fumes that could cause injury or loss of life to vent safely and will contribute toward maintaining the boiler's efficiency. **DO NOT** operate boiler with the absence of an approved vent system.

This boiler is supplied with controls which may cause the boiler to shut down and not re-start without service. If damage due to frozen pipes is a possibility, the heating system should not be left unattended in cold weather; or appropriate safeguards and alarms should be installed on the heating system to prevent damage if the boiler is inoperative.

This boiler is designed to burn No. 2 fuel oil only. **DO NOT** use gasoline, crankcase drainings, or any oil containing gasoline. Never burn garbage or paper in this boiler. **DO NOT** convert to any solid fuel (i.e. wood, coal). **DO NOT** convert to any gaseous fuel (i.e. natural gas, LP). All flammable debris, rags, paper, wood scraps, etc., should be kept clear of the boiler at all times. Keep the boiler area clean and free of fire hazards.

All boilers equipped with burner swing door have a potential hazard which if ignored can cause severe property damage, personal injury or loss of life. Before opening swing door, turn off service switch to boiler to prevent accidental firing of burner outside the combustion chamber. Be sure to tighten swing door fastener completely when service is completed.

TABLE OF CONTENTS

I. General Information	5	VIII. Boiler Cleaning	47
II. Pre-Installation	10	IX. Trouble Shooting.....	50
III. Installation Instructions.....	12	X. Repair Parts	53
IV. Electrical	26	XI. Burner Specifications	61
V. System Start-Up	32	Appendix A - Aftermarket Low Water Cut-Off	64
VI. Operating	39		
VII. Maintenance & Service Instructions.	44		

I: GENERAL INFORMATION

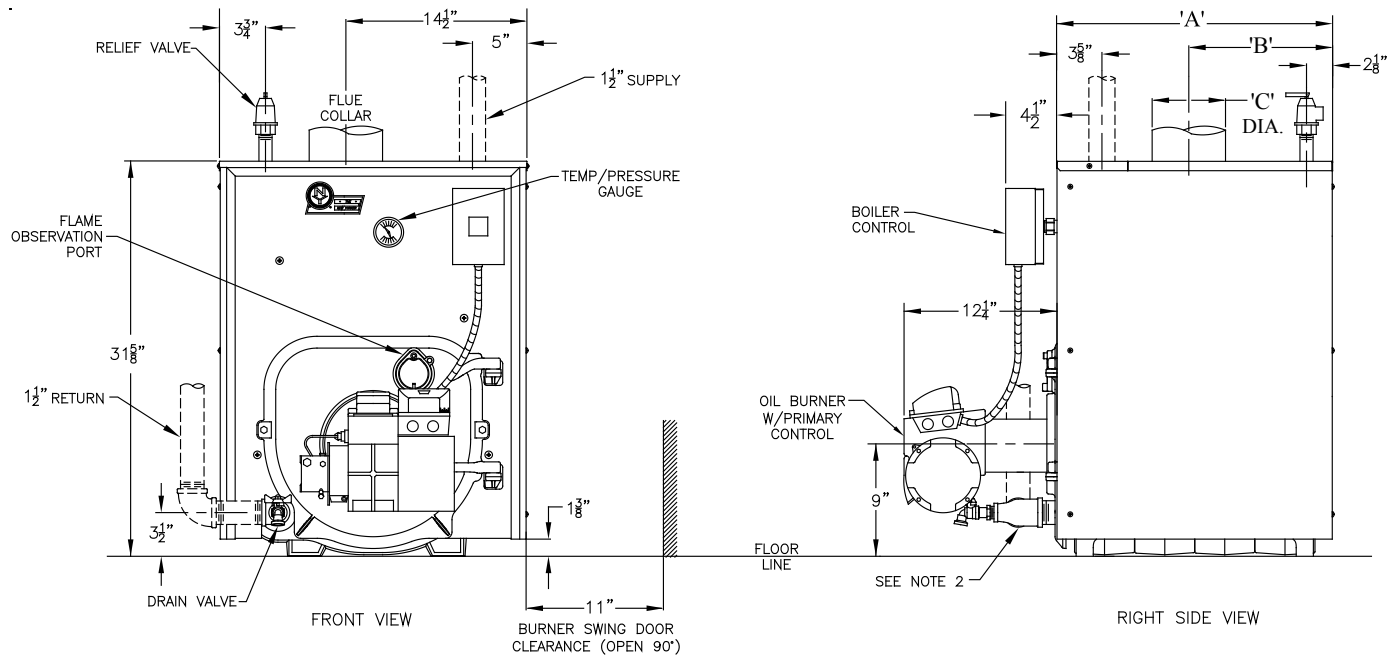

- NOTES:
1. CIRCULATOR SUPPLIED LOOSE - MAY BE INSTALLED ON SUPPLY OR RETURN.
 2. RETURN FITTINGS AND DRAIN VALVE SHIPPED LOOSE.
 3. PIPING SHOWN HIDDEN NOT FURNISHED WITH BOILER.

NOTE: For Carlin Burners Only: Burner extends in front of boiler 11-1/4", burner swing door clearance is 10", burner extends 2-5/8" above floor and burner is not available with cover.

Figure 1A: CL3 Thru CL5 Water Boiler without Tankless Heater, All Burner Options

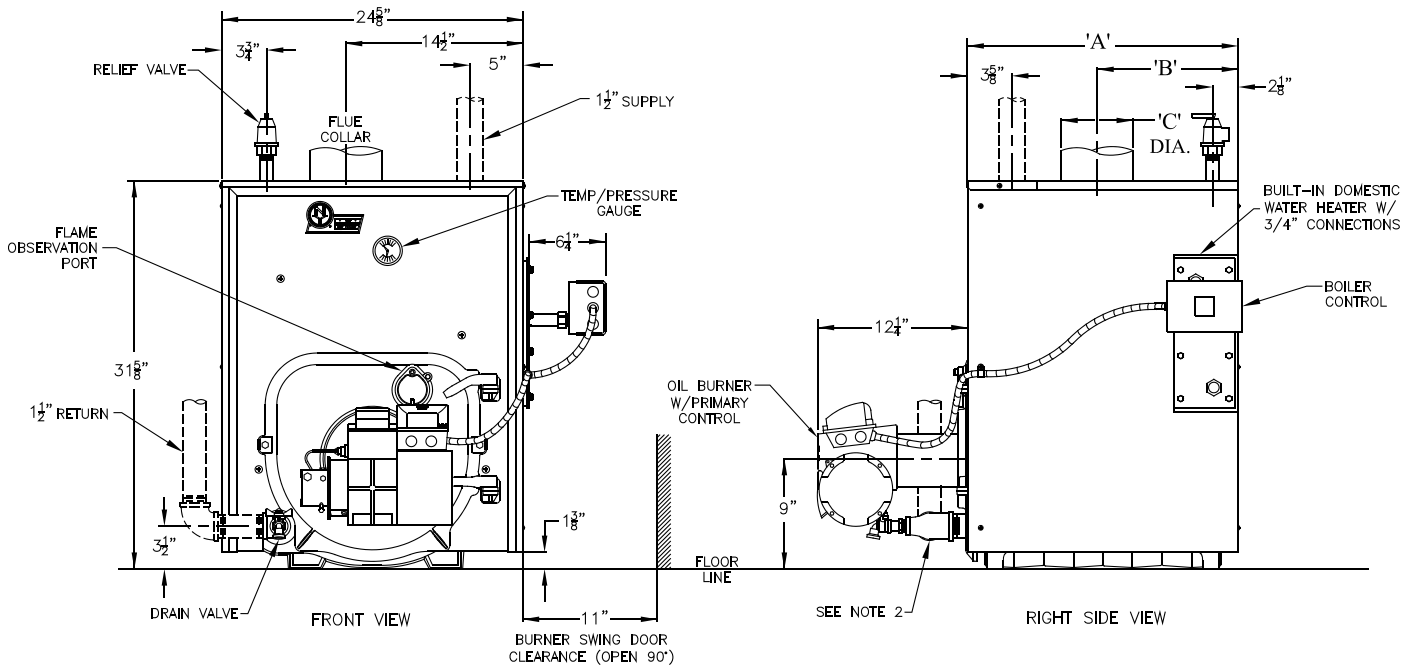

- NOTES:
1. CIRCULATOR SUPPLIED LOOSE - MAY BE INSTALLED ON SUPPLY OR RETURN.
 2. RETURN FITTINGS AND DRAIN VALVE SHIPPED LOOSE.
 3. PIPING SHOWN HIDDEN NOT FURNISHED WITH BOILER.

NOTE: For Carlin Burners Only: Burner extends in front of boiler 11-1/4", burner swing door clearance is 10", burner extends 2-5/8" above floor and burner is not available with cover.

Figure 1B: CL3 Thru CL5 Water Boiler With Tankless Heater, All Burner Options

I: GENERAL INFORMATION (continued)

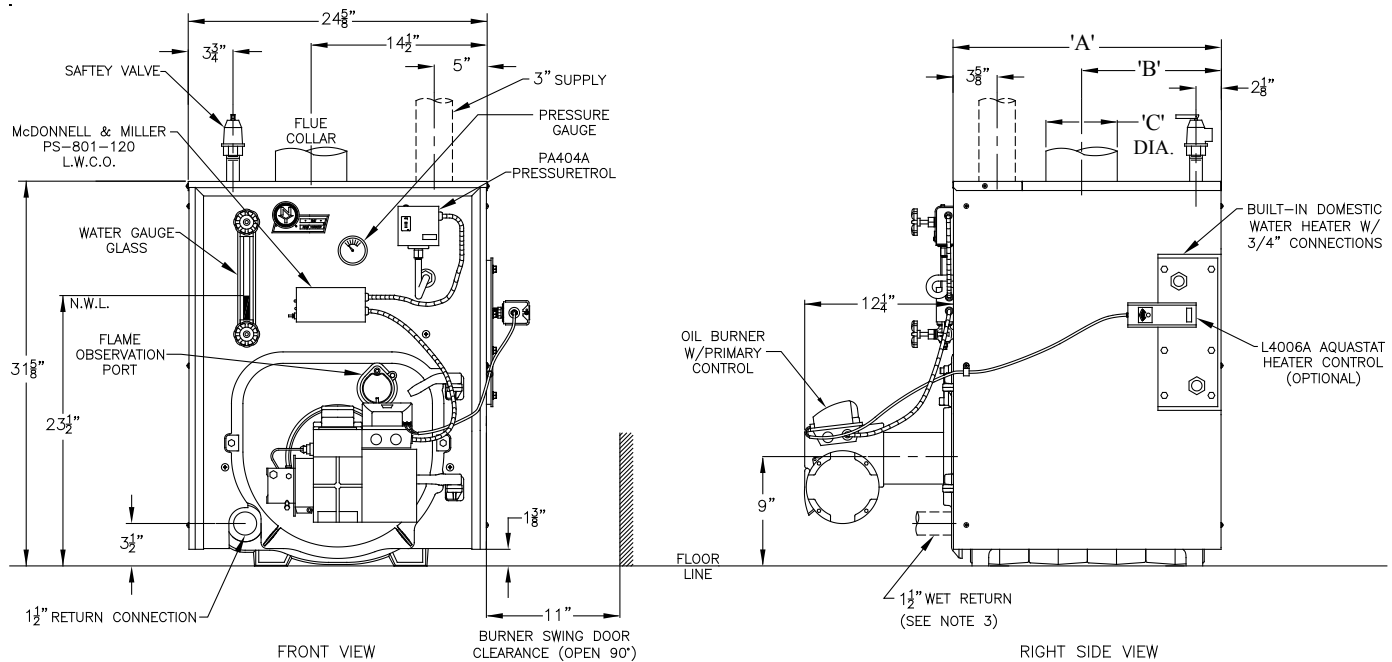

- NOTES:
1. TANKLESS COIL OPENING NOT PRESENT ON LESS-COIL BOILERS.
 2. PIPING SHOWN HIDDEN NOT FURNISHED WITH BOILER.
 3. DRAIN VALVE SHIPPED LOOSE. (NOT SHOWN)

NOTE: For Carlin Burners Only: Burner extends in front of boiler 11-1/4", burner swing door clearance is 10", burner extends 2-5/8" above floor and burner is not available with cover.

Figure 1C: CL3 Thru CL5 Steam Boiler with or without Tankless Heater, McDonnell & Miller PSE-801, Beckett and Carlin Burners

I: GENERAL INFORMATION (continued)

TABLE 1: DIMENSIONAL DATA / GENERAL INFORMATION (SEE FIGURES 1A THRU 1C)

Boiler Series	Dimensions			Approx. Water Content - Gallons	Heat Transfer Surface Area - Sq. Ft.
	"A"	"B"	"C"		
CL3	17-3/8"	8-1/4"	5-7/8"	16	14.33
CL4	22-3/8"	10-7/8"	6-7/8"	20	20.90
CL5	27-3/8"	13-3/8"	7-7/8"	24	27.46

Maximum Working Pressure: Steam: 15 PSI; Water: 30 PSI Shipped Standard from Factory, 50 PSI Optional



TABLE 2: RATING DATA

Boiler Series	Boiler Model	Burner Capacity		Heating Capacity ⁽²⁾		Net AHRI Ratings ⁽³⁾			AFUE %	Minimum Chimney Requirements		
		GPH	MBH	Water MBH ⁽¹⁾	Steam MBH	Water MBH	Steam MBH	Steam Sq. Ft.		Round In. Dia.	Rectangle In. x In.	Height Ft.
CL3-091(W)	CL3-091-W	0.65	91	80		70			86.1	6	8 x 8	15
CL3-091(S)	CL3-091S	0.65	91		78		59	233	84.1	6	8 x 8	15
CL3-105(W)	CL3-105-W	0.75	105	92		80			86.0	6	8 x 8	15
CL3-105(S)	CL3-105S	0.75	105		90		68	283	83.8	6	8 x 8	15
CL3-140(W)	CL3-140-W	1.00	140	120		104			84.3	6	8 x 8	15
CL3-140(S)	CL3-140S	1.00	140		119		89	370	82.7	6	8 x 8	15
CL4-126(W)	CL4-126-W	0.90	126	111		97			86.0	7	8 x 8	15
CL4-126(S)	CL4-126S	0.90	126		108		81	338	84.1	7	8 x 8	15
CL4-175(W)	CL4-175-W	1.25	175	151		131			85.1	7	8 x 8	15
CL4-175(S)	CL4-175S	1.25	175		149		112	467	83.5	7	8 x 8	15
CL4-210(W)	CL4-210-W	1.50	210	179		156			84.0	7	8 x 8	15
CL4-210(S)	CL4-210S	1.50	210		177		133	554	82.6	7	8 x 8	15
CL5-168(W)	CL5-168-W	1.20	168	147		128			85.9	8	8 x 8	15
CL5-168(S)	CL5-168S	1.20	168		144		108	450	83.7	8	8 x 8	15
CL5-245(W)	CL5-245-W	1.75	245	212		184			85.1	8	8 x 8	15
CL5-245(S)	CL5-245S	1.75	245		207		155	646	82.5	8	8 x 8	15
CL5-280(W)	CL5-280-W	2.00	280	241		210			84.7	8	8 x 8	15
CL5-280(S)	CL5-280S	2.00	280		235		176	733	82.3	8	8 x 8	15

⁽¹⁾ MBH refers to thousands of BTU per hour.

⁽²⁾ Based on standard test procedure prescribed by the United States Department of Energy at combustion conditions of 12.5% CO₂.

⁽³⁾ Net AHRI Ratings are based on piping and pickup allowance of 1.15 for water and 1.333 for steam.

I: GENERAL INFORMATION (continued)

TABLE 3A: PURPOSE OF TAPPINGS (WATER)

Tapping Location	Size, NPT	Purpose	
		Less Heater	With Heater
A	1½"	Return	
B	½"	Limit Well	Plug
C	¼"	Temperature/Pressure Gauge	
D	1½"	Supply	
E	1½"	Optional Return	
F	¾"	Relief Valve	
G	¾"	N/A	DHW Outlet
H	¾"	N/A	Limit Well
I	¾"	N/A	DHW Inlet

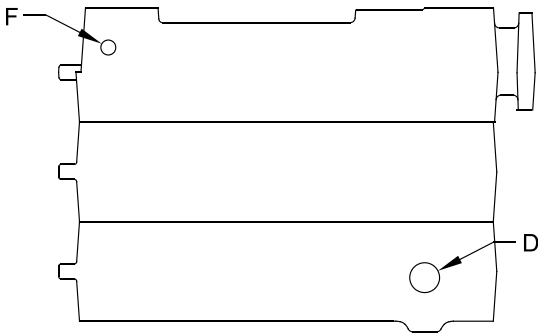

TOP VIEW

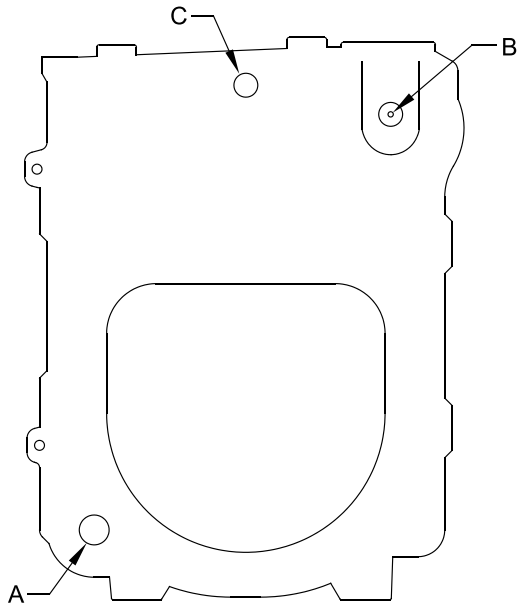

FRONT VIEW

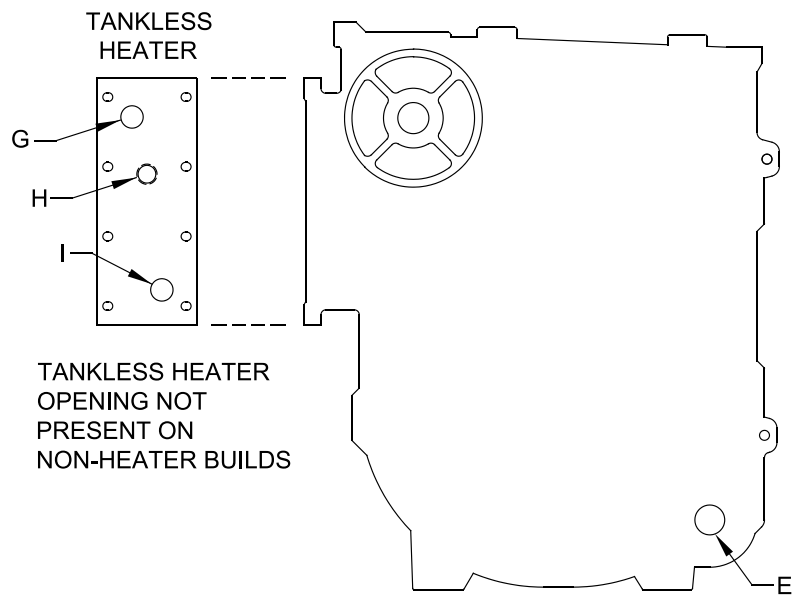

REAR VIEW

Figure 2A: Purpose of Tappings (Water)

I: GENERAL INFORMATION (continued)

TABLE 3B: PURPOSE OF TAPPINGS (STEAM)

Tapping Location	Size, NPT	Purpose	
		Less Heater	With Heater
A	1½"	Return	
B	½"	Pressure Limit	
C	¼"	Pressure Gauge	
D	3"	Supply	
E	1½"	Optional Return	
F	¾"	Relief Valve	
G	¾"	N/A	DHW Outlet
H	¾"	N/A	Limit Well
I	¾"	N/A	DHW Inlet
J	¾"	Drain	
K	¾"	LWCO	
L	½"	Water Gauge Glass	
M	½"	Water Gauge Glass	
N	1"	Indirect Water Heater Supply	
O	½"	Indirect Water Heater Limit	
P	1½"	Surface Blowoff	

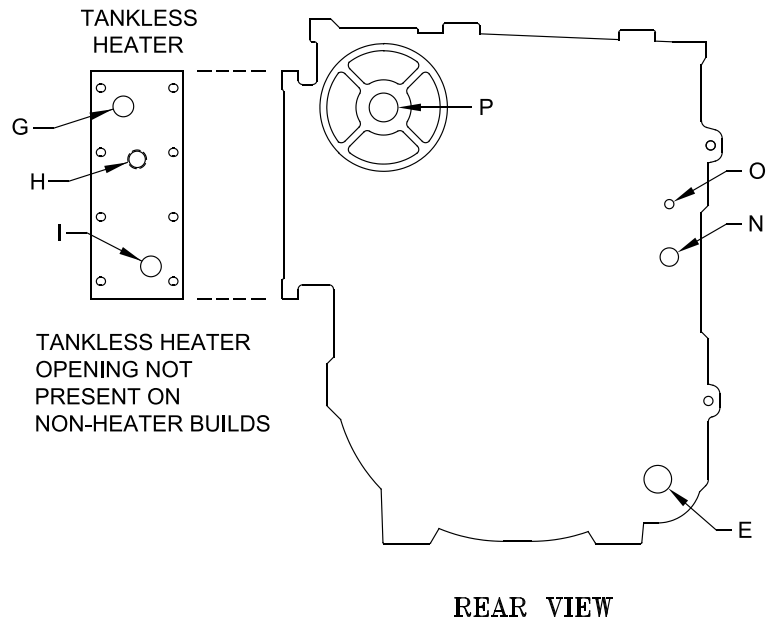
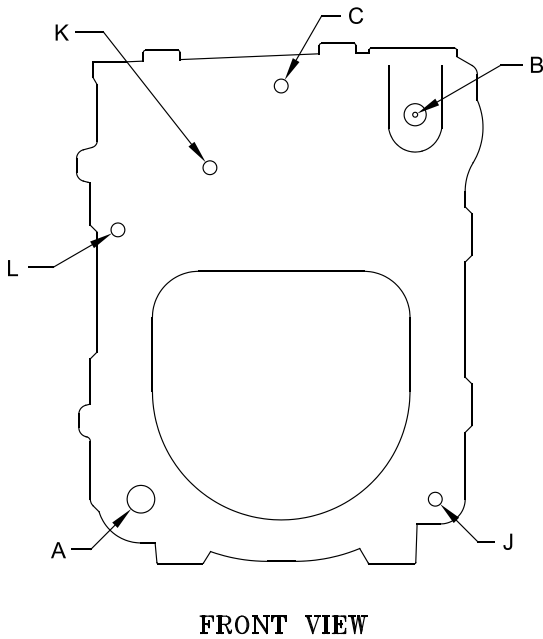
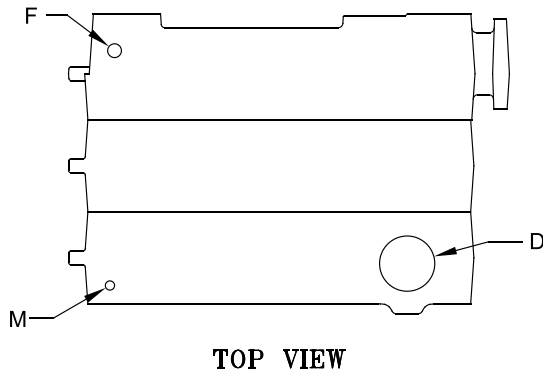

Figure 2B: Purpose of Tappings (Steam)

II: PRE-INSTALLATION

A. INSPECT SHIPMENT CAREFULLY FOR ANY SIGNS OF DAMAGE.

1. **All equipment** is carefully manufactured, inspected and packed. Our responsibility ceases upon delivery of crated boiler to the carrier in good condition.
2. **Any claims for damage or shortage** in shipment must be filed immediately against the carrier by the consignee. No claims for variances from, or shortage in orders, will be allowed by the manufacturer unless presented within sixty (60) days after receipt of goods.

B. LOCATE BOILER NEAR FINAL POSITION BEFORE REMOVING CRATE. See Figures 1A thru 1C. Using hand truck or pipe rollers under skid, move boiler into position along side installation site.

1. **Locate** so that vent pipe connection to chimney will be short and direct.
2. **Boiler is suitable for installation on combustible floor.** Boiler cannot be installed on carpeting.

3. **For basement installation**, provide a solid elevated base, such as concrete, if floor is not level, or if water may be encountered on floor around boiler.
4. **Provide service clearance** of at least 24" clearance from front jacket panel for servicing and removal of front tankless heater. If boiler is equipped with a rear tankless heater, provide at least 24" service clearance on the right side of the boiler. Boiler flueways may be cleaned either from the top or from the right side. Provide at least 24" clearance from either the right side of the boiler or the top of the boiler for cleaning flueways.
5. **For minimum clearances** to combustible materials. See Figure 3.

NOTICE

Clearance to venting is for single wall vent pipe. If Type L vent is used, clearance may be reduced to the minimum required by the vent pipe manufacturer.

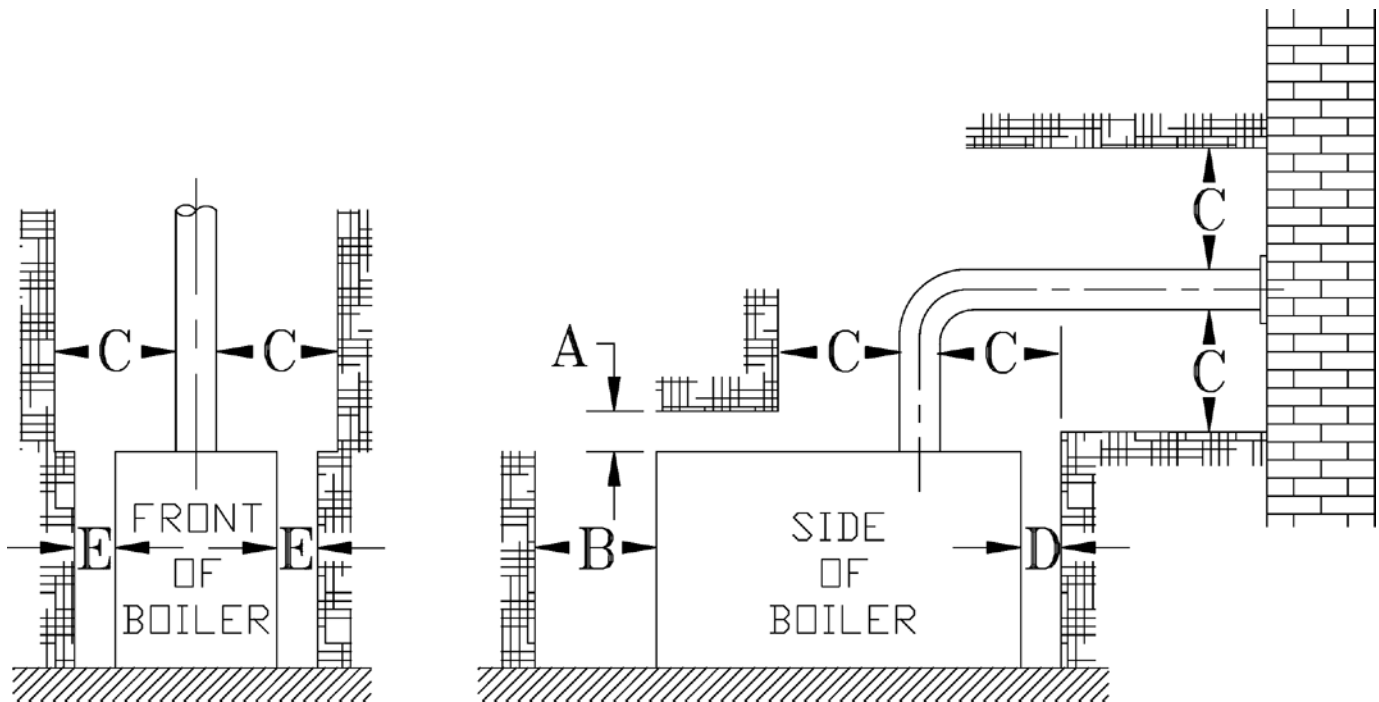

Figure 3: Minimum Installation Clearances To Combustible Materials (Inches)

A	B	C	D	E
Above	Front	Chimney Connector	Rear	Sides
6	24	18	6	6

NOTE 1: Listed clearances comply with American National Standard NFPA 31, Standard for the Installation of Oil Burning Equipment.

NOTE 2: CL Series boilers can be installed in rooms with clearances from combustible material as listed above. Listed clearances cannot be reduced for alcove or closet installations.

NOTE 3: For reduced clearances to combustible material, protection must be provided as described in the ANSI/NFPA 31 standard.

II: PRE-INSTALLATION (continued)

- C. **PROVIDE COMBUSTION AND VENTILATION AIR.** Local and National Codes may apply and should be referenced.

WARNING

Adequate combustion and ventilation air must be provided to assure proper combustion and to maintain safe ambient air temperatures.

DO NOT install boiler where gasoline or other flammable vapors or liquids, or sources of hydrocarbons (i.e. bleaches, fabric softeners, etc.) are used or stored.

- Determine volume of space** (boiler room). Rooms communicating directly with the space in which the appliances are installed, through openings not furnished with doors, are considered a part of the space.
$$\text{Volume}(\text{ft}^3) = \text{Length}(\text{ft}) \times \text{Width}(\text{ft}) \times \text{Height}(\text{ft})$$
- Determine total input** of all appliances in the space.
Add inputs of all appliances in the space and round the result to the nearest 1000 BTU per hour.
- Determine type of space.** Divide Volume by total input of all appliances in space. If the result is greater than or equal to 50 ft³/1000 BTU per hour, then it is considered an *unconfined space*. If the result is less than 50 ft³/1000 BTU per hour then the space is considered a *confined space*.
- For boiler located** in an *unconfined space of a conventionally constructed building*, the fresh air infiltration through cracks around windows and doors normally provides adequate air for combustion and ventilation.
- For boiler located in a confined space** or an unconfined space in a building of unusually tight construction, provide outdoor air.
Outdoor air may be provided with the use of two permanent openings which communicate directly or by duct with the outdoors or spaces (crawl or attic) freely communicating with the outdoors. Locate one opening within 12 inches of top of space.

Locate remaining opening within 12 inches of bottom of space. Minimum dimension of air opening is 3 inches. Size each opening per following:

- Direct communication with outdoors. Minimum free area of 1 square inch per 4,000 BTU per hour input of all equipment in space.
- Vertical ducts. Minimum free area of 1 square inch per 4,000 BTU per hour input of all equipment in space. Duct cross-sectional area shall be same as opening free area.
- Horizontal ducts. Minimum free area of 1 square inch per 2,000 BTU per hour input of all equipment in space. Duct cross-sectional area shall be same as opening free area.

Alternate method for boiler located within confined space. Use indoor air if two permanent openings communicate directly with additional space(s) of sufficient volume such that combined volume of all spaces meet criteria for unconfined space. Size each opening for minimum free area of 1 square inch per 1,000 BTU per hour input of all equipment in spaces, but not less than 100 square inches.

6. Louvers and Grilles of Ventilation Ducts

- All outside openings should be screened and louvered. Screens used should not be smaller than 1/4 inch mesh. Louvers will prevent the entrance of rain and snow.
- Free area requirements need to consider the blocking effect of louvers, grilles, or screens protecting the openings. If the free area of the louver or grille is not known, assume wood louvers have 20-25 percent free area and metal louvers and grilles have 60-75 percent free area.
- Louvers and grilles must be fixed in the open position, or interlocked with the equipment to open automatically during equipment operation.

III: INSTALLATION INSTRUCTIONS

A. REMOVE CRATE.

1. Remove all fasteners at crate skid.
2. Lift outside container and remove all other inside protective spacers and bracing. Remove miscellaneous steam or water trim carton.

B. REMOVAL OF BOILER FROM SKID.

1. Boiler is secured to base with 4 carriage bolts, 2 on left side and 2 on right side. See Figure 4. Remove all bolts.

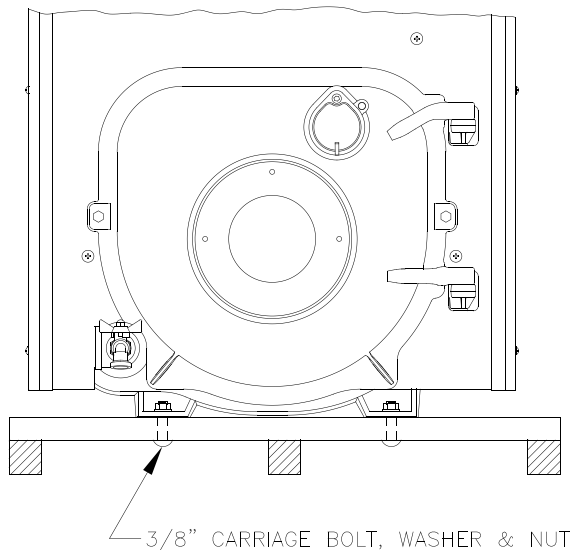

Figure 4: Removal of Boiler From Skid

2. Tilt boiler to right and to rear. Using right rear leg as pivot, rotate boiler 90° in a clockwise direction, and lower left side of boiler to floor. Tilt boiler and remove crate skid. Care should be exercised to prevent damage to jacket or burner.

C. MOVE BOILER TO PERMANENT POSITION BY SLIDING OR WALKING.

D. INSPECT COMBUSTION TARGET WALL AND COMBUSTION CHAMBER LINER.

1. Open flame observation door and/or burner swing door on front of boiler. Use flashlight to inspect target wall secured to rear section with silastic sealant. Inspect ceramic fiber blanket secured to floor of boiler with water glass adhesive. If either is damaged they must be replaced.

E. INSTALL OIL BURNER.

1. Open burner carton and remove contents. Refer to Tables 14A, 14B and 14C as well as the burner parts table on page 60 for proper burner specification.
2. Place oil burner gasket on burner and align holes.

CAUTION

Do not install burner without Gasket.

3. Remove four (4) 5/16-18 x 3/4" long cap screws from burner swing door used for mounting burner.
4. Insert oil burner into opening of burner swing door. Align the top slotted hole in burner flange with the top hole on the burner swing door. Install one (1) cap screw.
5. Align remaining holes and install the three (3) remaining cap screws.

F. INSPECT NOZZLE, ELECTRODES INSERTION DEPTH AND TURBULATOR SETTING/CHANGE FIRING RATE:

1. CL™ Series boilers are shipped with the highest input oil nozzle installed in the burner. Oil nozzles for lower firing rates are shipped loose attached to the burner. Select the proper oil nozzle for the installation. The lower input nozzle will provide greater boiler efficiency. However, boiler output will be reduced. Refer to Table 2 for firing rates.
2. On the Beckett AFG Burner, use the following procedure to complete the inspection, check the settings and to change the nozzle to a lower firing rate:
 - a. Loosen two (2) igniter latching screws, rotate tabs and swing open igniter about hinge.
 - b. Loosen knurled nut and disconnect copper connector tube.
 - c. Remove nozzle line electrode assembly.
 - d. If high firing rate is desired, confirm the nozzle is the proper size and type, refer to Table 14A (at rear of this manual), then proceed to Item i. below.
 - e. If a lower input is desired, remove the nozzle that was factory installed.
 - f. Remove Beckett MB(L1) or MD(V1) head.
 - g. Locate the desired nozzle. Refer to Table 14A (at rear of this manual) for proper nozzle. The nozzle must be securely installed to assure leak free joints between the nozzle and adapter. When installing the nozzle, be careful not to bump or move the burner electrodes.

Note: On the CL3-091 (0.65 GPH) burner application, a low firing rate baffle is required. Baffle is shipped loose with nozzles. Install baffle per Beckett Instruction included with baffle.

III: INSTALLATION INSTRUCTIONS (continued)

- h. Reinstall Beckett MB(L1) or MD(V1) Head.
 - i. Inspect and measure burner electrodes. Refer to Figure 27 for the proper electrode setting. Readjust electrode setting to the proper dimensions if necessary. Refer to Figure 27.
 - j. Reinstall nozzle line electrode assembly.
 - k. Connect copper connector tube.
 - l. Inspect Beckett head setting on left side of burner by insuring the line on the label MB(L1) or the blue line MD(V1) are aligned, readjust if necessary. Refer to Figure 27.
 - m. Tighten knurled nut.
 - n. Swing igniter closed, rotate tabs and tighten two (2) igniter screws.
3. **On the Riello 40 Series Oil Burner**, use the following procedure to complete the inspection, check the settings and to change the nozzle to a lower firing rate: Refer also to *Model F3 & F5 Installation Manual, Riello 40 Series Residential Oil Burners (C6501010)* or *Model F10 Installation Manual, Riello 40 Series Residential Oil Burners No. 2902554*.

a. Installation/Removal of Drawer Assembly, refer to Figure 5.

i. Removal:

- Disconnect oil delivery tube nut from pump.
- Loosen SCREW (3), and then unplug PRIMARY CONTROL (1) by carefully pulling it back and then up.
- Remove the AIR TUBE COVER PLATE (5) by loosening the retaining SCREW (4) (Two SCREWS-Model F5).
- Loosen SCREW (2), and then slide the complete drawer assembly out of the combustion head as shown.

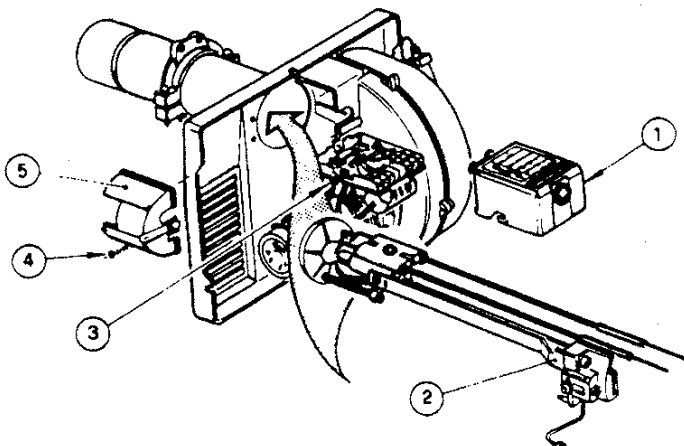

Figure 5: Installation/Removal of Riello Drawer Assembly

- ii. Installation:
To insert drawer assembly, reverse the procedure in Step *i* above.
- b. Nozzle Replacement, refer to Figure 6.
- i. Remove the NOZZLE ADAPTER (2) from the DRAWER ASSEMBLY by loosening the SCREW (1).
 - ii. Remove existing nozzle from nozzle adapter.
 - iii. Insert the proper NOZZLE into NOZZLE ADAPTER and tighten securely (**DO NOT** cover tighten), refer to Table 14B (at rear of this manual).
 - iv. Replace adapter, with nozzle installed, into drawer assembly and secure with screw (1).

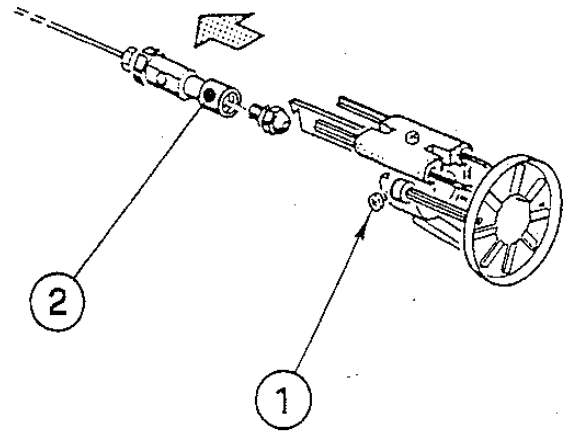

Figure 6: Riello Nozzle Replacement

- c. Inspect and measure burner electrodes. Refer to Figure 7 for the proper electrode settings.
- d. Re-install Drawer Assembly into Combustion Head per Step 3a above.
- e. Insertion Depth, verify the distance between the tip of the end cone is equal to the distance specified in Table 14B (at rear of this manual).
- f. Turbulator Setting, refer to Figure 8.
- g. Pump Connections and Port Identification, refer to Figure 9.

IMPORTANT: THESE DIMENSIONS MUST BE OBSERVED AND VERIFIED.

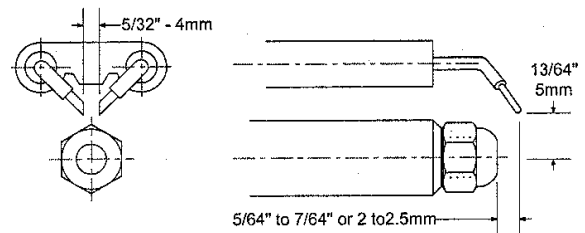

Figure 7: Riello Electrode Setting

III: INSTALLATION INSTRUCTIONS (continued)

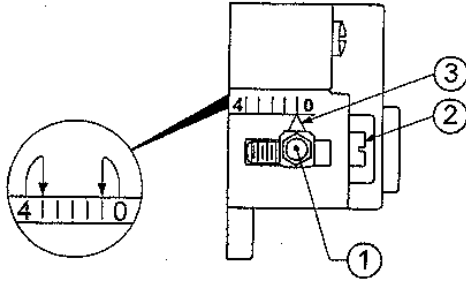

Figure 8: Riello Turbulator Setting

This burner is shipped with the oil pump set to operate on a **single** line system. To operate on a **two-line** system the bypass plug must be installed.

WARNING: DO NOT operate a **single** line system with the by-pass plug installed. Operating a **single** line system with the by-pass plug installed will result in damage to the pump shaft seal.

Note: Pump pressure was factory pre-set but must be checked at time of burner start-up. A pressure gauge is attached to the **PRESSURE/ BLEEDER PORT (7)** for pressure readings. Two **PIPE CONNECTORS (4)** are supplied with the burner for connection to either a single or two-line system. Also supplied are two **ADAPTORS (3)**, two female 1/4" NPT to adapt oil lines to burner pipe connectors. All pump port threads are **British Parallel Thread** design. Direct connection of NPT threads to the pump **will damage** the pump body.

Riello manometers and vacuum gauges **DO NOT** require any adapters, and can be safely connected to the pump ports. An NPT x metric adapter **must** be used when connecting other gauge models.

h. Replace Burner Cover and Tighten Burner Cover Screws.

4. On the Carlin EZ-PH Burner, use the following procedure to complete the inspection, check the settings and to change the nozzle to a lower firing rate:
 - a. Loosen two (2) igniter latching screws, rotate tabs and swing open igniter about hinge.
 - b. Loosen knurled nut and disconnect copper connector tube.
 - c. Remove nozzle line electrode assembly from burner.
 - d. **If high firing rate is desired**, confirm the nozzle is the proper size and type, refer to Table 14C (at rear of this manual), then proceed to Item i.
 - e. **If a lower input is desired**, remove the flame retention head and then remove the nozzle that was factory installed.
 - f. Locate the desired nozzle, refer to Table 14C (at rear of this manual) for proper nozzle. The nozzle must be securely installed to assure leak free joints between the nozzle and adapter. When installing the nozzle, be careful not to bump or move the burner electrodes.
 - g. Reinstall Flame Retention Head on Nozzle Line Electrode Assembly. Make sure the clamp is fully seated against the shoulder on the nozzle adapter before securing.
 - h. Loosen and remove the retaining nut and factory installed head bar from side of burner housing. Install the proper head bar that corresponds to the desired firing rate, refer to Table 14C (at rear of this manual), and tighten retaining nut.
 - i. Readjust air band to preliminary setting that corresponds to the lower firing rate nozzle installed, refer to Table 14C (at rear of this manual).
 - j. Inspect and measure burner electrodes. Refer to Figure 10 for proper electrode setting. Readjust electrode setting to the proper dimensions if necessary.

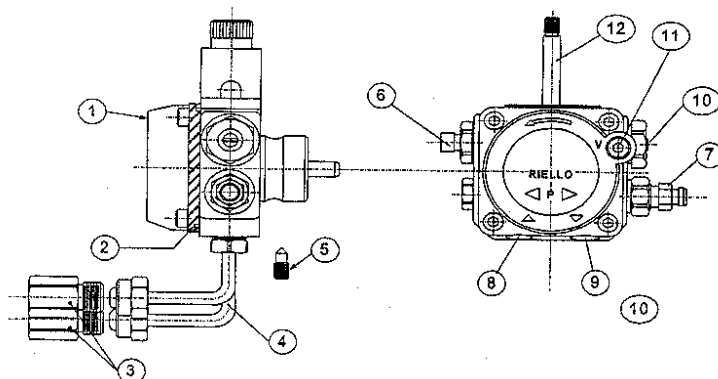

PUMP LEGEND

1. PUMP COVER
2. PUMP COVER O-RING
3. BSPP TO NPT ADAPTORS
4. SUPPLY AND RETURN OIL LINES
5. RETURN PORT BY PASS SCREW
6. NOZZLE PORT - PUMP OULET TO NOZZLE
7. PUMP PRESSURE PORT AND BLEEDER PORT
8. PUMP SUPPLY PORT
9. PUMP RETURN PORT
10. PUMP PRESSURE REGULATING SCREW
11. VACUUM PORT
12. PUMP VALVE STEM

Figure 9: Riello Pump Connections and Port Identification

III: INSTALLATION INSTRUCTIONS (continued)

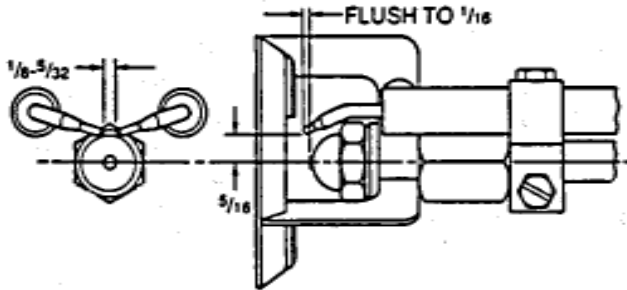

Figure 10: Electrode Settings

- k. Reinstall nozzle line electrode assembly.
- l. Reconnect copper connector tube.
- m. Tighten knurled nut.
- n. Close igniter, rotate and tighten two (2) igniter latching screws.

G. INSTALL WATER BOILER TRIM AND CONTROLS, (see Figures 1A and 1B).

1. **Install return piping** supplied with boiler. Apply Teflon or Sealant to all joints prior to assembly. Thread 1½" NPT x 5" Lg. return nipple into 1½" NPT tapping located in lower left corner of front section. Thread 1½" x ¾" x 1½" NPT tee onto 5" nipple. Thread ¾" drain valve into ¾" NPT connection on tee. Tighten all joints with wrench until water tight and 1½" NPT return connection on tee is facing away from boiler horizontally to allow for proper burner swing door clearance, see Figures 1A, 1B, 12A and 12B.

Note: Vertical piping will prevent door from opening fully for service and cleaning of boiler.

2. **Thread relief valve** onto factory installed ¾" NPT x 7¼" nipple located in left rear corner on top of boiler as shown in Figures 1A and 1B. Valve spindle must be in vertical position. Tighten with wrench. Pipe discharge as shown in Figures 12A and 12B. Installation of the relief valve must be consistent with ANSI/ASME Boiler and Pressure Vessel Code, Section IV.
3. **Connect Field Wiring**
Connect the field wiring to the Warm or Cold Start Intelligent Oil Boiler Control (Boiler Control). Make the wiring connections as shown in Figure 21 and 22.
 - a. On water boilers without rear tankless heater, connect the field wiring from the circulator to the Cold Start Boiler Control and from the Cold Start Boiler Control to the Burner Oil Primary Control. Make the wiring connections as shown on Figure 21.

- b. On water boilers with rear tankless heater, the factory wired Warm Start Boiler Control was not installed in heater. Locate ¾" NPT immersion well, apply sealant, thread into ¾" NPT tapping on tankless heater and tighten with wrench. Apply heat transfer paste (not furnished) to limit sensor and fully insert limit sensor into immersion well such that the tip on the limit sensor touches the bottom of the immersion well. See Figure 11. Tighten clamp screws to secure Warm Start Boiler Control to immersion well. Secure Boiler Control conduit to jacket right side panel with 5/8" cable clamp provided, refer to Figure 1B. Make the wiring connections as shown on Figure 22.

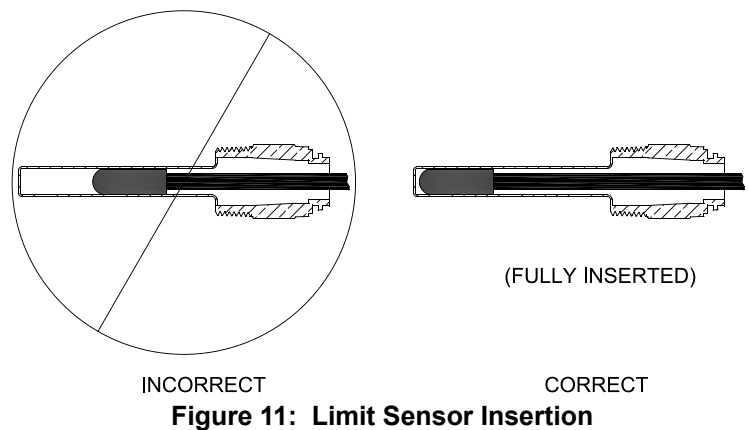
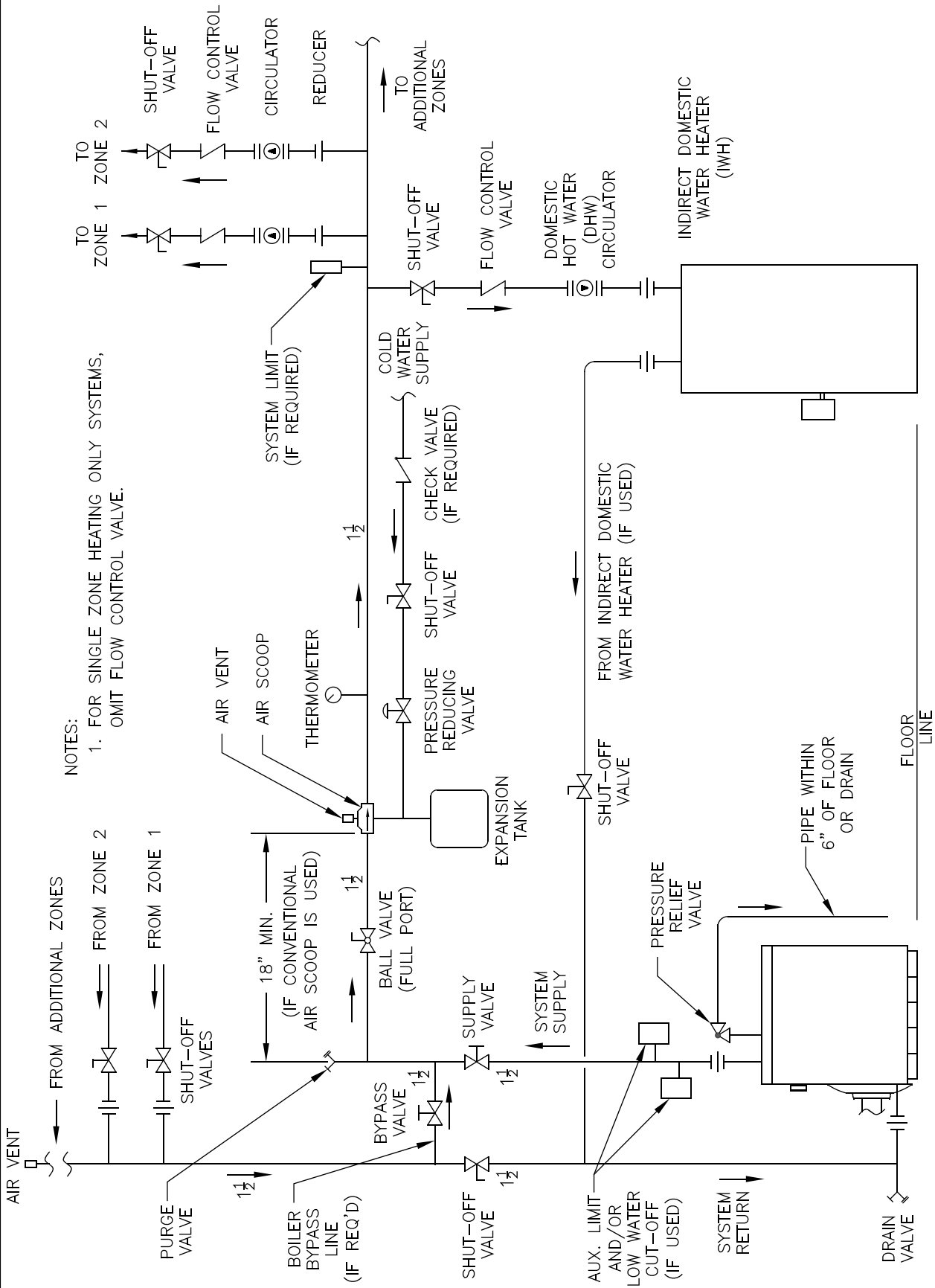

Figure 11: Limit Sensor Insertion

H. INSTALL STEAM BOILER TRIM AND CONTROLS, (SEE FIGURE 1C).

1. **Thread ¾" MPT safety valve** and ¾" NPT coupling onto factory installed ¾" NPT x 7¼" nipple located in left rear corner on top of boiler as shown in Figure 1C. Tighten with wrench. Pipe discharge as shown in Figure 13. Installation of the relief valve must be consistent with ANSI/ASME Boiler and Pressure Vessel Code, Section IV.
2. **Install ¾" drain valve** in wet return piping as shown in Figure 13.
3. **On boilers with rear tankless heater**, factory wired L4006A Aquastat Heater Control was not installed in heater. Locate ¾" NPT Immersion Well, apply sealant and thread into ¾" NPT tapping on heater. Apply heat transfer paste (not furnished) to control bulb and insert bulb into immersion well. Tighten clamping screws to secure Boiler Control to immersion well. Secure 18/2 Control Cable Wire to jacket right side panel with 5/16" cable clamp provided, refer to Figure 1C.

16 III: INSTALLATION INSTRUCTIONS (continued)



RIGHT SIDE VIEW

Figure 12A: Recommended Water Piping for Circulator Zoned Heating System - Supply Side Circulator

III: INSTALLATION INSTRUCTIONS (continued)

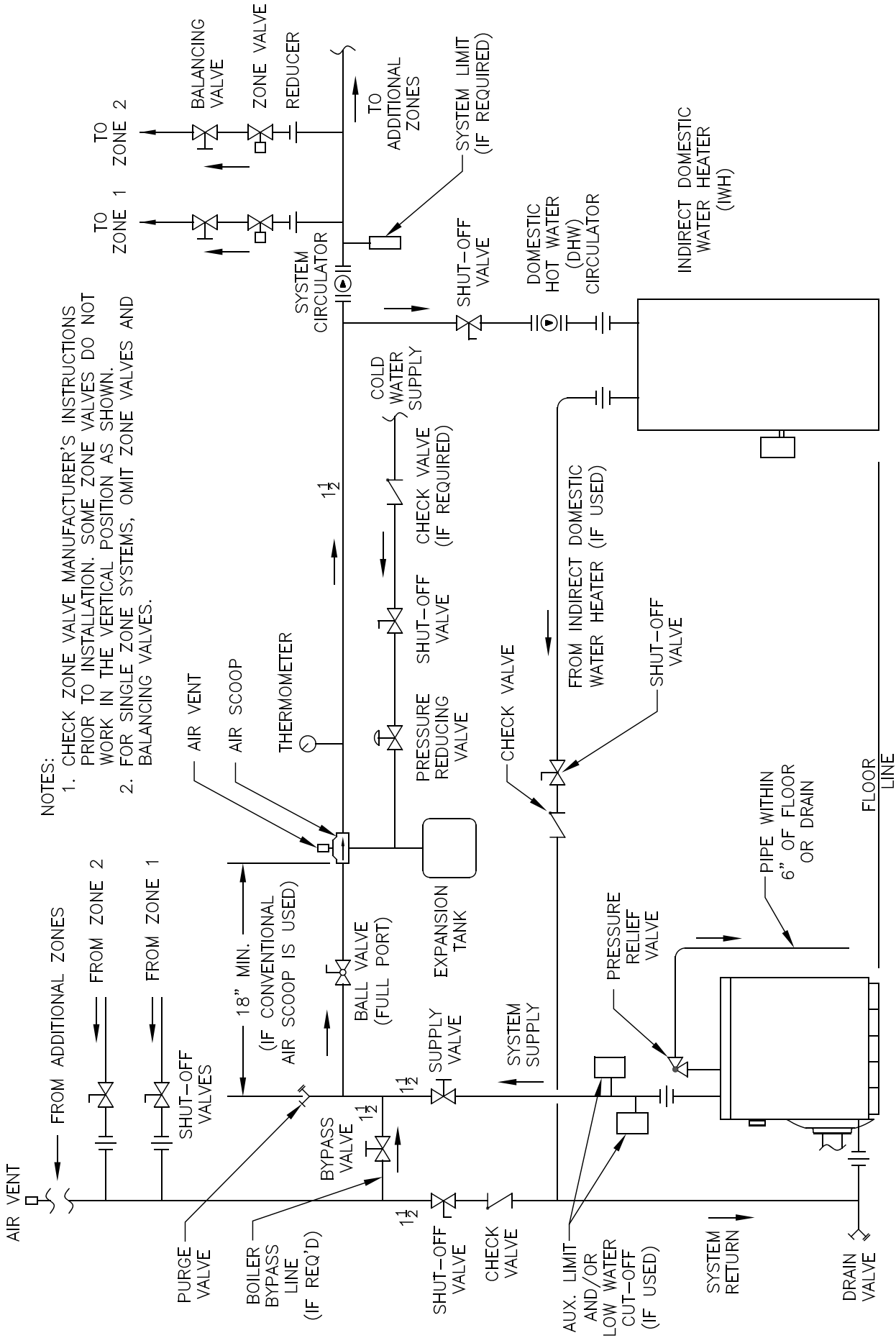

RIGHT SIDE VIEW
Figure 12B: Recommended Water Piping for Zone Valve Zoned Heating System - Supply Side Circulator

III: INSTALLATION INSTRUCTIONS (continued)

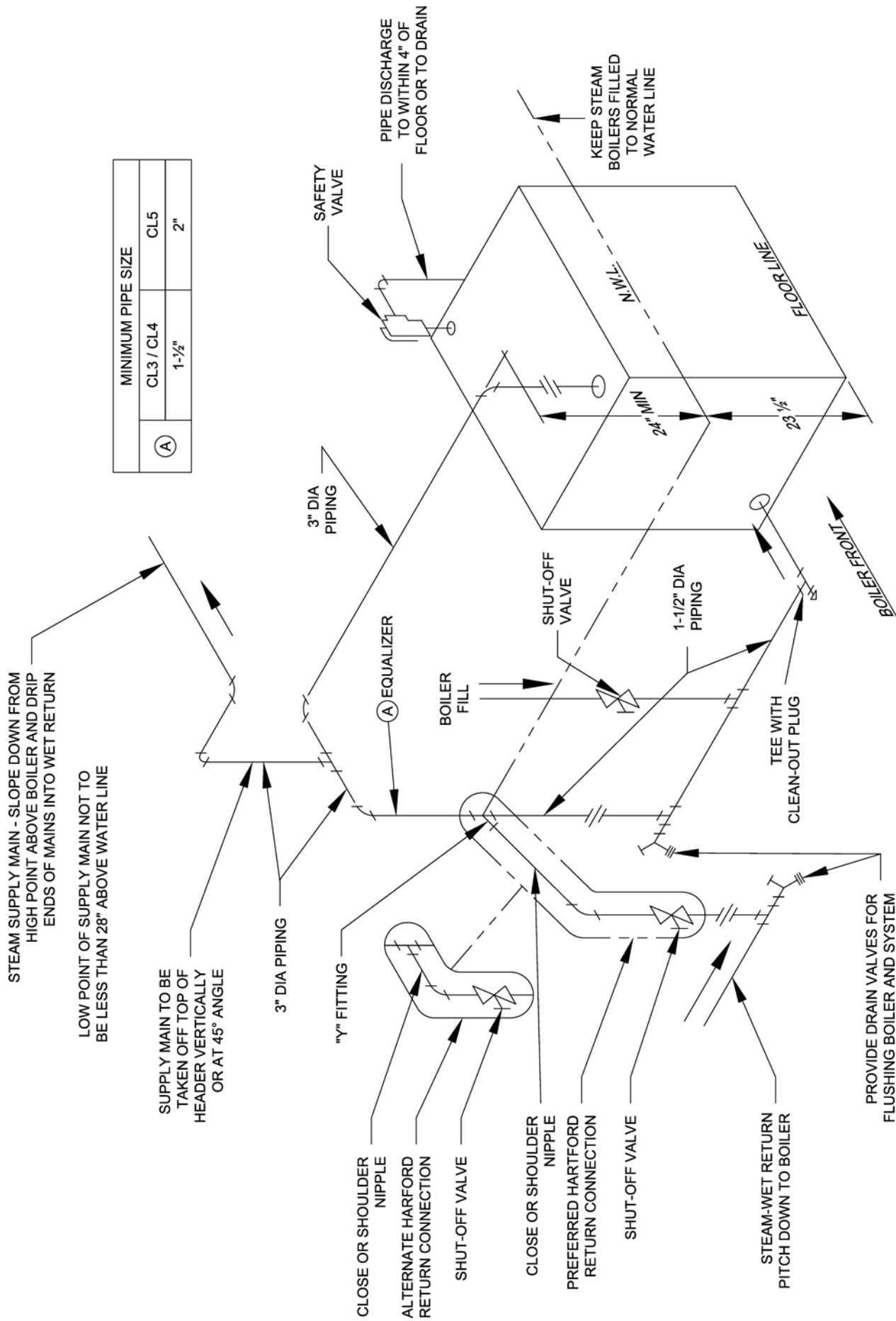

Figure 13: Recommended Boiler Piping for Gravity Return Steam Boiler

III: INSTALLATION INSTRUCTIONS (continued)

4. Connect Field Wiring

- a. Connect the field wiring to the pressure limit, the LWCO and the burner or primary control. If equipped with tankless heater, connect field wiring from the Aquastat Control to the Oil Primary Control "TT" terminals. Make the wiring connections as shown in Figure 23.

Note:

- The GeniSys 7505 Oil Primary Control has pre-installed "T-T" jumper. To activate "T-T" terminals, "T-T" jumper must be removed.
- **DO NOT** remove "T-T" jumper **unless** wiring diagram indicates a direct connection from thermostat and/or tankless heater aquastat control to the oil burner primary control's "T-T" terminal. Refer to Figure 23.

I. CONNECT SUPPLY AND RETURN PIPING TO HEATING SYSTEM.

1. **Clearances** — Steam and hot water pipes shall have clearances of at least ½" from all combustible construction.

2. Water Boiler

- a. For Forced Circulation HOT WATER HEATING. See Figures 12A and 12B. Consult I=B=R, "Residential Hydronic Heating Installation and Design Guide".
- b. Use a boiler water bypass if the boiler is to be operated in a system which has a large volume or excessive radiation where low boiler water temperature may be encountered (i.e. converted gravity circulation system, etc.).

Install a pipe tee in the boiler return piping along with a second tee in the supply piping as shown in Figures 12A and 12B. The bypass should be the same size as the supply and return lines. Locate valves in the bypass and supply outlet as illustrated in Figures 12A and 12B for regulation of water flow to maintain higher boiler water temperature.

Set the by-pass and boiler supply valves to a half throttle position to start. Operate boiler until the system water temperature is a normal operating range.

Adjust the valves to provide 180° to 200°F supply water temperature. Opening the boiler supply valves will raise the system temperature, while opening the bypass valve will lower the system supply temperature.

- c. If this boiler is connected to heating coils located in air handling units where they may be exposed to refrigerated air the boiler piping must be equipped with flow control valves to prevent gravity circulation of boiler water during the operation of the cooling system.
- d. If this boiler is used in connection with refrigeration systems, the boiler must be installed so that the chilled medium is piped in parallel with the heating boiler using appropriate valves to prevent the chilled medium from entering the boiler, see Figure 14. Also, consult I=B=R, "Residential Hydronic Heating Installation and Design Guide".

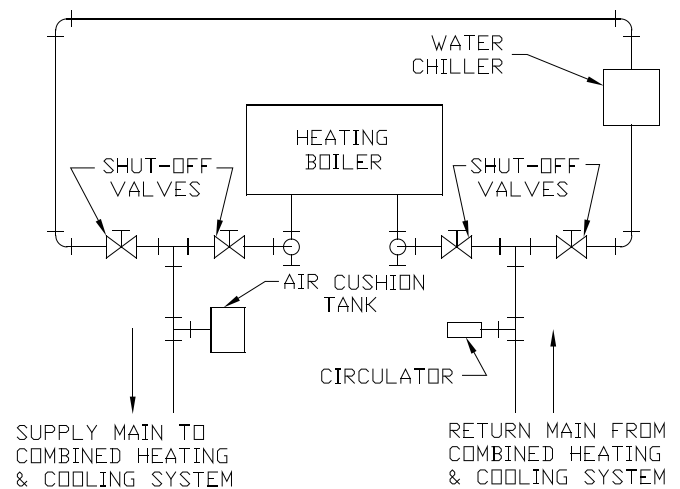

Figure 14: Recommended Piping for Combination Heating & Cooling (Refrigeration) Systems

NOTICE

Before using copper for steam piping, consider the following characteristics of copper piping:

- 1) High coefficient of thermal expansion can induce mechanical stresses and cause expansion/contraction noises if not accounted for in the piping system design and installation,
- 2) **High heat transfer rate (heat loss) of un-insulated copper piping must be included in the normal piping and pickup factors used to size the boiler,**
- 3) **Soldering or brazing pastes and fluxes that end up in the system can cause poor heat transfer, surging, an unsteady water line and wet steam if not thoroughly removed during boil out procedure and,**
- 4) **Galvanic corrosion of the adjoining metal may occur due to dissimilar metals in certain water chemistries if dielectric unions are not used.**

III: INSTALLATION INSTRUCTIONS (continued)

- e. A hot water boiler installed above radiation level must be provided with a low water cutoff device as part of the installation. See Appendix A, Low Water Cut-Off for additional details.

3. Steam Boiler

- a. For Recommended STEAM BOILER PIPING refer to Figure 13. Also, consult I=B=R, "Residential Hydronic Heating Installation and Design Guide".
- b. Evaluate the Existing Steam System.
The single most important factor in determining the expected life cycle of a steam boiler, is the amount of fresh water added to the boiler during operation. Fresh water brings minerals and oxygen into the boiler. These contaminants greatly accelerate corrosion of the cast iron boiler sections.
 - i. Assure that all system radiators, piping and vents are absolutely leak tight.
 - When a steam boiler is installed in an existing system, ALL air vents should be replaced at the same time. This assures that the new boiler will not be compromised by existing system leaks.
 - If the system contains hidden supply or return piping (hidden behind walls, buried in concrete, etc.) pressure test this piping to assure there are no leaks.
 - ii. Repair any leaks in the system.
 - iii. Install accurate water meter on the fresh water supply to the boiler.

- iii. Eliminating and/or repairing fittings which allow oxygen absorption.
- iv. Use of non-permeable materials in the distribution system.
- v. Isolating the boiler from the system water by installing a heat exchanger.

See Section VII, Paragraph B, Step 3 for additional details.

CAUTION

Oxygen contamination of the boiler water will cause corrosion of iron and steel boiler components, and can lead to boiler failure. New Yorker's Standard Warranty does not cover problems caused by oxygen contamination of boiler water or scale (lime) build-up caused by frequent addition of water.

J. CONNECT TANKLESS HEATER PIPING AS SHOWN IN FIGURE 15. See Table 4 for Tankless Heater Ratings.

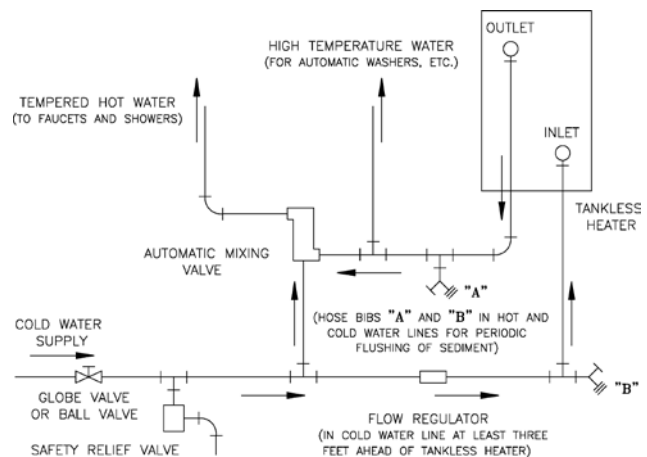

Figure 15: Schematic Tankless Heater Piping

TABLE 4: TANKLESS HEATER DATA

Boiler Series	Rating (Gal/Min)		Pressure Drop (PSI)	
	Steam	Water	Steam	Water
CL3-091	2.25	2.75	2.3	3.9
CL3-105	2.25	3.00	2.3	4.7
CL3-140	2.50	3.25	3.1	5.6
CL4-126	2.50	3.25	3.1	5.6
CL4-175	2.75	3.75	3.9	7.2
CL4-210	3.00	4.00	4.7	8.0
CL5-168	2.75	3.50	3.9	6.4
CL5-245	3.25	4.25	5.6	8.8
CL5-280	3.50	4.75	6.4	9.6

NOTICE

DO NOT use softened water in steam boilers. Accelerated boiler corrosion will result. Tie in fresh water supply to the boiler upstream of a water softener.

4. Oxygen Contamination:

- a. There are many possible causes of oxygen contamination such as:
 - i. Addition of excessive make-up water as a result of system leaks.
 - ii. Absorption through open tanks and fittings.
 - iii. Oxygen permeable materials in the distribution system.
- b. In order to insure long product life, oxygen sources should be eliminated. This can be accomplished by taking the following measures:
 - i. Repairing system leaks to eliminate the need for addition of make-up water.
 - ii. Eliminating open tanks from the system.

III: INSTALLATION INSTRUCTIONS (continued)

The following guidelines should be followed when piping the tankless heater:

1. **Flow Regulation** — If flow through the heater is greater than its rating, the supply of adequate hot water may not be able to keep up with the demand. For this reason a flow regulator matching the heater rating should be installed in the cold water line to the heater. The flow regulator should preferably be located below the inlet to the heater and a minimum of 3' away from the inlet so that the regulator is not subjected to excess temperatures that may occur during "off" periods when it is possible for heat to be conducted back through the supply line. The flow regulator also limits the flow of supply water regardless of inlet pressure variations in the range of 20 to 125 psi.
2. **Tempering Hot Water** — Installation of an automatic mixing valve will lengthen the delivery of the available hot water by mixing some cold water with the hot. This prevents excessive and possibly scalding hot water at the fixtures. In addition, savings of hot water will be achieved since the user will not waste as much hot water while seeking water temperature to his liking. Higher temperature hot water required by dishwashers and automatic washers is possible by piping the hot water from the heater prior to entering the mixing valve. The mixing valve should be "trapped" by installing it below the cold water inlet to heater to prevent lime formation in the valve.

WARNING

Install automatic mixing valve at tankless heater outlet to avoid risk of burns or scalding due to excessively hot water at fixtures. Adjust and maintain the mixing valve in accordance with the manufacturer's instructions.

3. **Flushing of Heater** — All water contains some sediment which settles on the inside of the coil. Consequently, the heater should be periodically backwashed. This is accomplished by installing hose bibs as illustrated and allowing water at city pressure to run into hose bib A, through the heater, and out hose bib B until the discharge is clear. The tees in which the hose bibs are located should be the same size as heater connections to minimize pressure drop.
4. **Hard Water** — A water analysis is necessary to determine the hardness of your potable water. This is applicable to some city water and particularly to well water. An appropriate water softener should be installed based on the analysis and dealer's recommendation. This is not only beneficial to the

tankless heater but to piping and fixtures plus the many other benefits derived from soft water.

K. INDIRECT WATER HEATER PIPING

1. **Connect Indirect Water Heater Piping** as shown in Figures 12A and 12B for water boilers and Figures 13 and 16 for steam boilers. Refer to Indirect Water Heater Instruction Manual for additional installation information.
 - a. **CL Series Water Boiler** - Figures 12A and 12B show indirect water heater piping on typical hot water heating system. Boiler piping is the same as for any two-zone system. Figures 12A and 12B show circulator zoning, which is usually preferred for indirect water heaters. Size the circulator and indirect water heater piping to obtain the boiler water flow through the indirect water heater called for by the indirect water heater manufacturer. Refer to the indirect water heater instruction manual for additional details.
 - b. **CL Series Steam Boiler** - All CL Series steam boilers are equipped with tappings to permit the connect of an indirect water heater, see Figures 2B and 16. In this type of system, hot boiler water is drawn from below the water line and passed through the heat exchanger in the indirect water heater.
This section describes boiler-side piping only. Refer to the indirect water heater instruction manual for additional details.

L. CHIMNEY VENTING

1. **Chimney venting** is an important part of a safe and efficient oil fired appliance system. Contact your local fire and building officials on specific requirements for restrictions and the installation of fuel oil burning equipment. In addition, consult with a professional knowledgeable on the requirements of NFPA 31 – Standard for the Installation of Oil-Burning Equipment and NFPA 211 - Standard for Chimneys, Fireplaces, Vents, and Solid Fuel-Burning Appliances for installations in the United States. Installations in Canada must be reviewed with a professional knowledgeable on the requirements of CSA B139 – Installation Code for Oil-burning Equipment.
2. **The safe venting of oil fired boilers** is dependant on many factors. Some of these factors include:
 - a. sufficient draft during the entire heating season to allow for the safe discharge of combustion by-products and;
 - b. suitable corrosion protection in the event of condensing flue gases. Only a trained and qualified contractor may install this product.

III: INSTALLATION INSTRUCTIONS (continued)

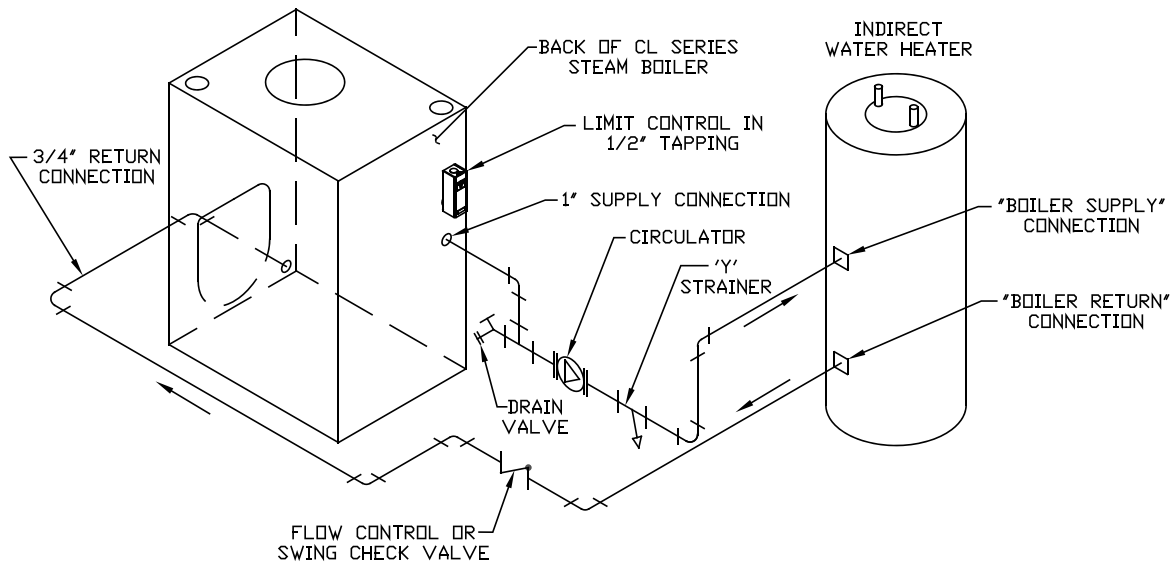

Figure 16: Indirect Water Heater Piping on CL Series Steam Boiler

WARNING

Vent this boiler according to these instructions. Failure to do so may cause products of combustion to enter the home resulting in severe property damage, personal injury or death.

Insufficient Combustion Air Supply may result in the production and release of deadly carbon monoxide (CO) into the home which can cause severe personal injury or death.

Improper venting may result in property damage and the release of flue gases which contain deadly carbon monoxide (CO) into the home, which can cause severe personal injury, death, or substantial property damage.

Inspect existing chimney and vent connector for obstructions and deterioration before installing boiler. Failure to clean or replace perforated pipe or chimney liner will cause severe injury or death.

Do not de-rate the appliance. Failure to fire the boiler at it's designed input may cause excessive condensation upon the interior walls of the chimney. In addition, the lower input may not create enough draft to adequately evacuate the by-products of combustion.

3. **The CL shall be vented** into any of the following:
 - a. Masonry or metal chimney. Build and install in accordance with local buildings codes; or local authority having jurisdiction; or "Standards for Chimney, Fireplace, Vents, and Solid Fuel Burning Appliances", ANSI/NFPA 211 and/or National Building Code of Canada. Masonry chimney must be lined with listed chimney system. Listed clay flue lined masonry chimneys meet venting requirements.
 - External chimneys are more susceptible to flue gas condensation due to colder outside air temperatures. To prevent corrosion due to flue gas condensation, use a listed corrosion-resistant metal liner in chimney.
 - Oversized chimneys are more susceptible to flue gas condensation. To reduce the likelihood of flue gas condensation and ensure proper draft, use a properly sized listed metal liner in oversized chimney.

4. **Chimney Inspection** – Prior to the installation of any new or replacement fuel burning equipment the chimney shall be inspected by a qualified installer. The chimney shall be inspected for integrity as well as for proper draft and condensate control. Some jurisdictions require the use of a liner when changing fuel types. Some jurisdictions require the use of a liner even when the same fuel is used. At a minimum, the chimney shall be examined by a qualified person in accordance with the requirements of Chapter 11 of NFPA 211, Standard for Chimneys, Fireplaces, Vents, and Solid Fuel-Burning Appliances.
 - a. Loose Mortar – Loose mortar could be an indication of a prior history of condensing flue gases upon the inside walls of the chimney. Colder climates are more susceptible to this condition. Under no circumstances shall a chimney of this condition be used until it meets the requirements of NFPA 211 or CSA B139.

III: INSTALLATION INSTRUCTIONS (continued)

- b. Unlined Chimney – Under no circumstances shall a chimney constructed of brick only be used. Only approved clay liners or listed chimney lining systems shall be used as specified in NFPA 31 or CSA B139.
 - c. Abandoned Openings – Openings through the chimney wall that are no longer used shall be sealed in accordance to NFPA 211. Often abandoned openings are improperly sealed and usually covered by a gypsum wall covering.
 - d. Clean Chimney – Chimney shall be free of all loose debris.
5. Draft Regulator – a draft regulator must be used with this appliance. Refer to Figures 17 and 18.

Chimney Connector

DANGER

The chimney and connector shall be inspected annually for signs of debris and corrosion. Loose mortar at the base of the chimney may be a sign of condensate damage to the chimney. A chimney professional shall be contacted immediately to examine the damage and recommend a solution. Long term operation while in this condition may cause a venting failure and force flue gases into the living space. If the chimney is to be re-lined use the recommendations in NFPA 31, Appendix E or CSA B139.

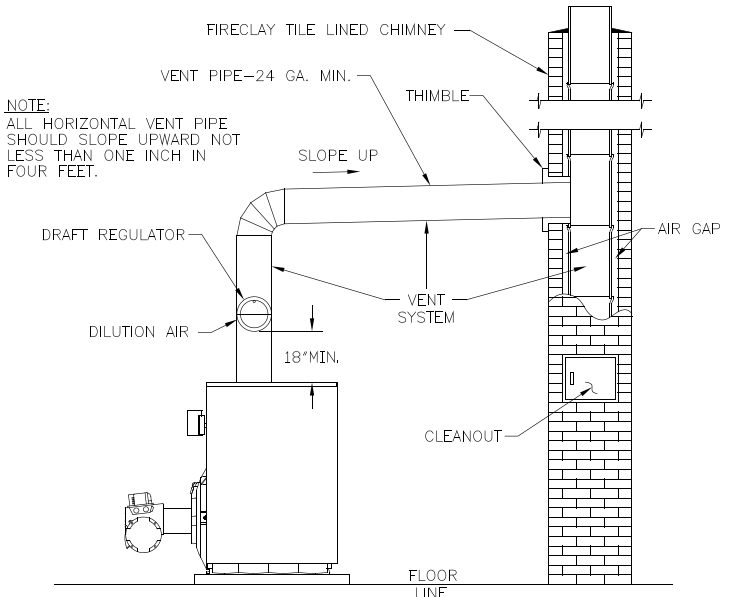

Figure 17: Recommended Smokepipe Arrangement and Chimney Requirements

1. A chimney connector (vent pipe) is used to connect the boiler to the base of the chimney. The chimney connector should be kept as short as possible. The horizontal length of the chimney connector shall not be greater than 10 feet.
2. Vent Connector shall be any of the following and of the same size as the outlet of boiler.

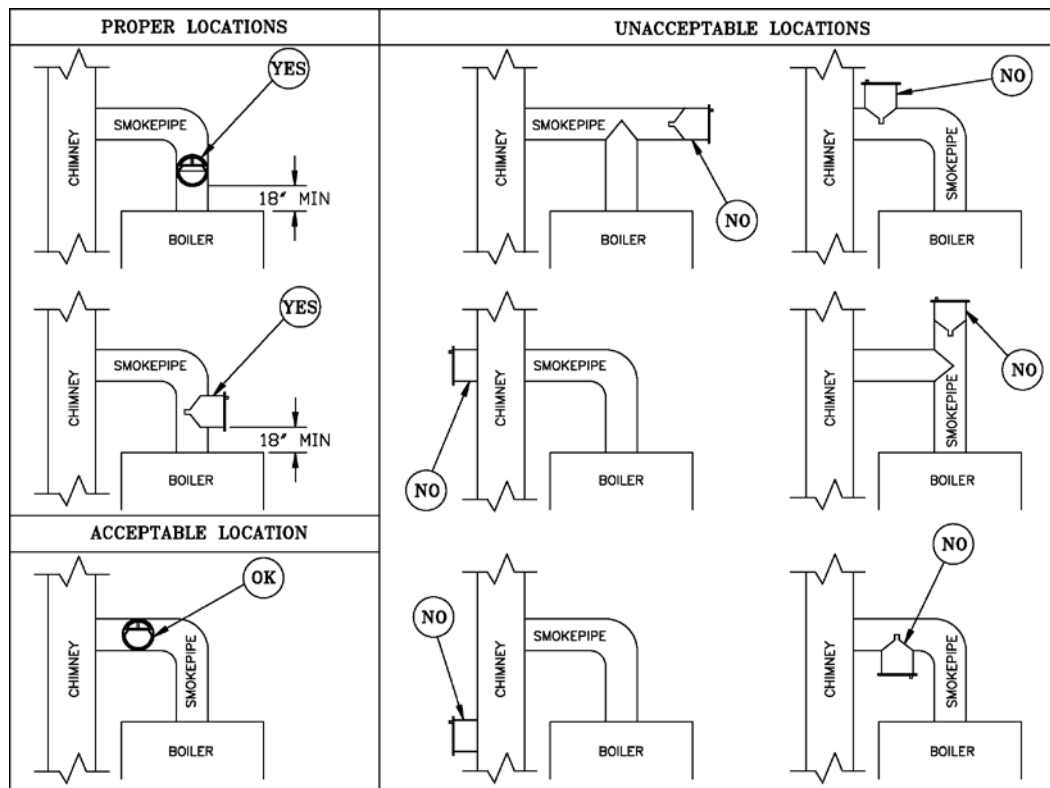

Figure 18: Proper and Improper Locations of Draft Regulator

III: INSTALLATION INSTRUCTIONS (continued)

- a. Type L or a factory built chimney material that complies with the Type HT requirements of ANSI/UL 103. Install in accordance with listing and manufacturer's instructions.
- b. Steel pipe having resistance to corrosion and heat with a minimum wall thickness of 24 Gauge (0.024").

DANGER

Any signs of condensate seepage at the base of the chimney shall be inspected immediately. The discoloration may be a sign of chimney damage and must be remedied immediately.

Draft

1. **The natural draft** generated through a chimney is dependent on several factors including, chimney height, temperature of flue gases, cross section area of chimney, chimney wall insulation value, dilution air and total volume of flue gases, to name a few. Make sure that the boiler has been running for at least 5 minutes before measuring the draft.
2. **Minimum Draft Overfire** – The draft induced by a chimney must create at least a pressure of -0.02 inches water column (" w.c.). The pressure at the canopy cannot be positive since this could create a condition that allows flue gas by-products to escape from the draft regulator. A negative pressure reading up to -.03 inches water column is acceptable for proper operation.

Stack Temperature

1. **The temperature of the flue gases** has a significant effect on the amount of draft created in a vertical chimney as well as the propensity to create condensate. The higher the stack temperature, the greater the amount of draft that can be generated. A lower stack temperature not only reduces the amount of draft that can be created but it also increases the possibility that the flue gases could condense in the chimney connector or stack.
2. **NFPA 31 and CSA B139** have information to help the installer make an appropriate choice of venting materials. In some cases a chimney may have to be lined to create sufficient draft. In other cases, the chimney may have to be lined to prevent the corrosion of a masonry chimney. Consult with a chimney specialist knowledgeable on the requirements for chimney requirements in your area.

CAUTION

Any doubt on the condition of a chimney or its ability to prevent the generation and accumulation of flue gas condensate, must be relined according to NFPA 31 (United States) or CSA B139 (Canada).

CAUTION

Use the chimney venting tables as a guide. It is highly recommended that any borderline application should result in the relining of the chimney with a suitable liner that creates sufficient draft and to protect against corrosion caused by flue gas condensate.

IMPORTANT

Single-pipe installations must be absolutely airtight or leaks or loss of prime may result. Bleed line and fuel unit completely.

M. FUEL UNITS AND OIL LINES

Single-Pipe Oil Lines - Standard burners are provided with single-stage 3450 rpm fuel units with the by-pass plug removed for single-pipe installations.

The single-stage fuel unit may be installed single-pipe with gravity feed or lift. Maximum allowable lift is 8 feet. See Figure 19.

Two-Pipe Oil Lines - For two-pipe systems where more lift is required, the two-stage fuel unit is recommended. Table 5 (single-stage) and Table 6 (two-stage) show allowable lift and lengths of 3/8-inch and 1/2-inch OD tubing for both suction and return lines. Refer to Figure 20.

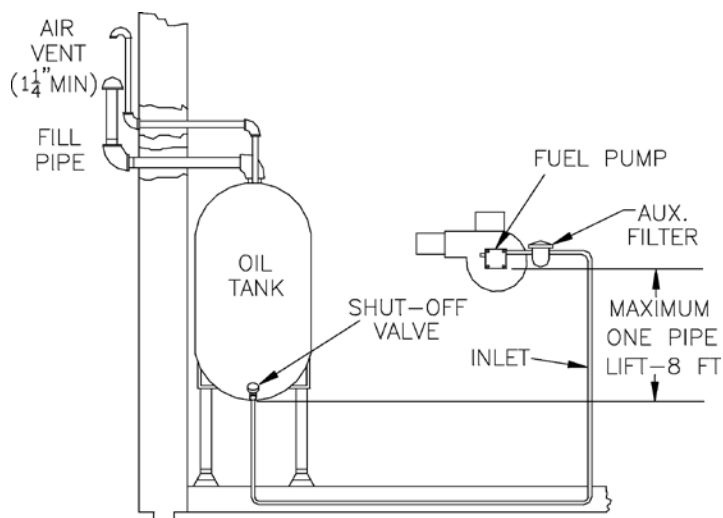

Figure 19: Single Pipe Oil Line

III: INSTALLATION INSTRUCTIONS (continued)

**TABLE 5: SINGLE STAGE UNITS (3450 RPM)
TWO PIPE SYSTEMS**

Lift "H" (See Figure)	Maximum Length of Tubing "H" + "R" (See Figure)	
	3/8" OD Tubing (3 GPH)	1/2" OD Tubing (3 GPH)
0'	84'	100'
1'	78'	100'
2'	73'	100'
3'	68'	100'
4'	63'	100'
5'	57'	100'
6'	52'	100'
7'	47'	100'
8'	42'	100'
9'	36'	100'
10'	31'	100'
11'	26'	100'
12'	21'	83'
13'	---	62'
14'	---	41'

**TABLE 6: TWO-STAGE UNITS (3450 RPM)
TWO-PIPE SYSTEMS**

Lift "H" (See Figure)	Maximum Length of Tubing "H" + "R" (See Figure)	
	3/8" OD Tubing (3 GPH)	1/2" OD Tubing (3 GPH)
0'	93'	100'
2'	85'	100'
4'	77'	100'
6'	69'	100'
8'	60'	100'
10'	52'	100'
12'	44'	100'
14'	36'	100'
16'	27'	100'
18'	---	76'

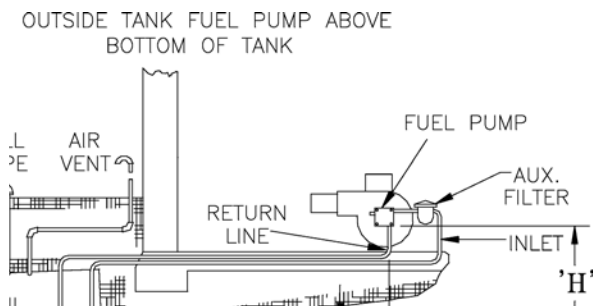

Figure 20: Two Pipe Oil Lines

Be sure that all oil line connections are absolutely airtight. Check all connections and joints. Flared fittings are recommended. Do not use compression fittings.

Open the air-bleed valve and start the burner. For clean bleed, slip a 3/16" ID hose over the end of the bleed valve and bleed into a container. Continue to bleed for 15 seconds after oil is free of air bubbles. Stop burner and close valve.

IV: ELECTRICAL

DANGER

Positively assure all electrical connections are unpowered before attempting installation or service of electrical components or connections of the boiler or building. Lock out all electrical boxes with padlock once power is turned off.

WARNING

Failure to properly wire electrical connections to the boiler may result in serious physical harm.

Electrical power may be from more than one source. Make sure all power is off before attempting any electrical work.

Each boiler must be protected with a properly sized fused disconnect.

Never jump out or make inoperative any safety or operating controls.

WARNING

The primary control may be damaged or may not function properly if 120 volt power supply is **NOT** wired into control as follows:

The 120V interrupted hot (black) wire must be connected to the primary control black wire, the 120V neutral (white) wire must be connected to the primary control white wire and the 120V constant hot (red) wire must be connected to the primary control red wire.

A. GENERAL

1. **Install wiring** and electrically ground boiler in accordance with requirements of the authority having jurisdiction, or in absence of such requirements the National Electrical Code, ANSI/NFPA 70.
2. **Refer to** National Electric Code or Local Electric Codes for proper size and type of wire required. Follow Code.
3. A **separate electrical circuit** must be run from the main electrical service with an over-current device/disconnect in the circuit. A service switch is recommended and may be required by some local jurisdictions.
4. **Use anti-short bushings** on all wiring passing through boiler jacket, junction boxes and/or control boxes.
5. **Use armored cable (BX)** over all exposed line voltage wiring.

6. **If an indirect domestic water heater** is used, use priority zoning. DO NOT use priority zoning for Hydro-Air Systems.
7. **Wiring should conform** to Figures 21 through 25.

- B. INSTALL A ROOM THERMOSTAT** on an inside wall about four feet above floor. Never install thermostat on an outside wall or where it will be influenced by drafts, hot or cold water pipes, lighting fixtures, television, rays of the sun or near a fireplace. Keep large furniture away from thermostat so there will be free movement of room air around this control.
- Heat Anticipator in Thermostat should be set to match the requirements of the control to which it is connected. See Figures 21 through 25 for desired system and heat anticipator setting. If system tends to overheat above the thermostat's temperature setting, reduce heat anticipator setting by .1 or .2 amps. If system tends to short cycle without reaching desired room temperature, increase heat anticipator setting by .1 or .2 amps.

IV: ELECTRICAL (continued)

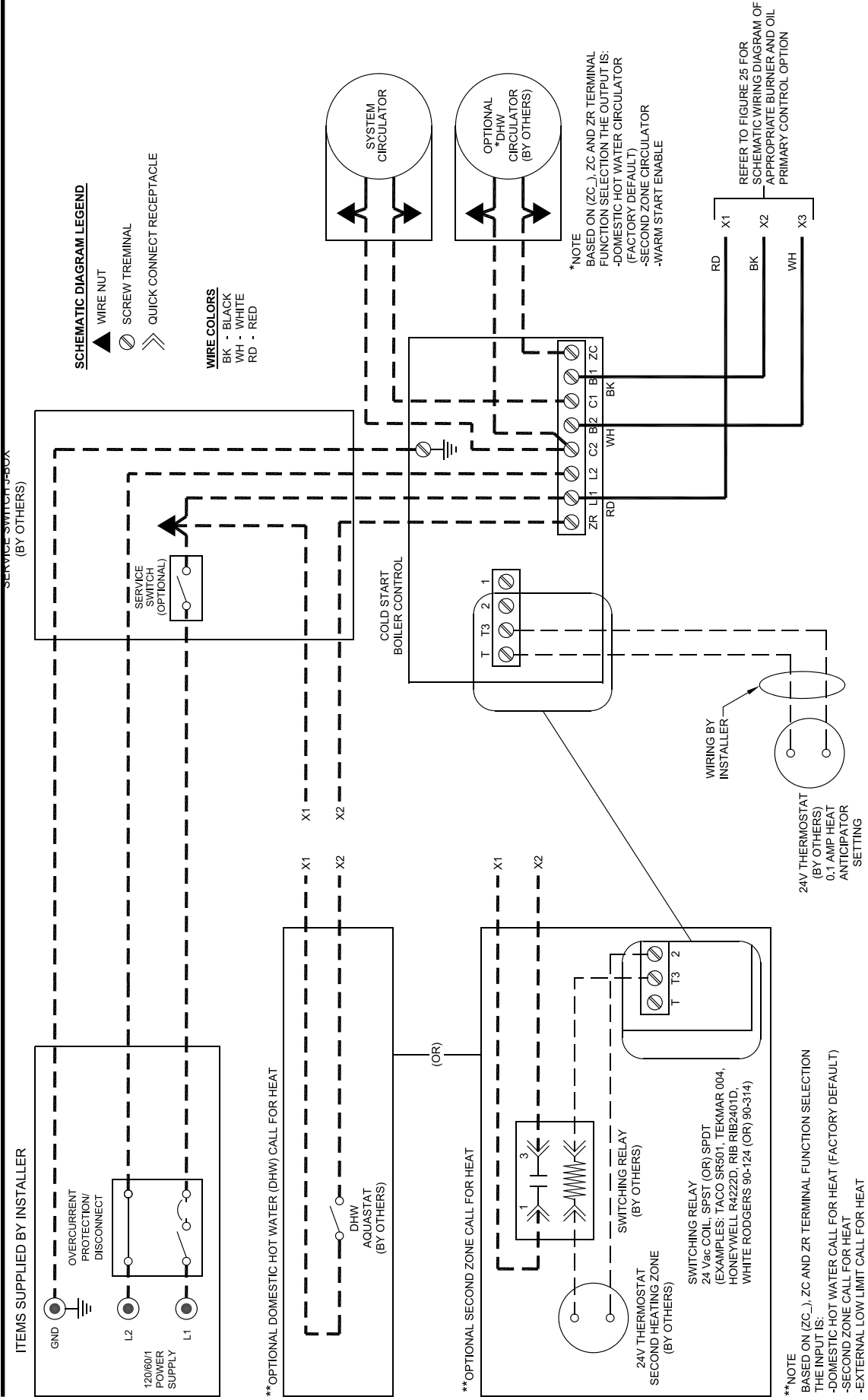

WIRE TYPE LEGEND

— LOW VOLTAGE FACTORY WIRING (SIZE 18 AWG, 105°C)
- - - LOW VOLTAGE FIELD WIRING
— LINE VOLTAGE FACTORY WIRING (SIZE 18 AWG, 105°C)
- - - LINE VOLTAGE FIELD WIRING

NOTES:

- IF ANY ORIGINAL EQUIPMENT WIRE AS SUPPLIED WITH THE APPLIANCE MUST BE REPLACED, IT MUST BE REPLACED WITH WIRE HAVING THE SAME WIRE GAUGE (AWG), SAME WIRE TYPE AND RATED FOR A MINIMUM OF 105°C. **DO NOT REMOVE JUMPER ON OIL PRIMARY CONTROL FOR THIS APPLICATION.**

Figure 21: Schematic Wiring Diagram, without Tankless Heater, Cold Start Control (All Burners)

IV: ELECTRICAL (continued)

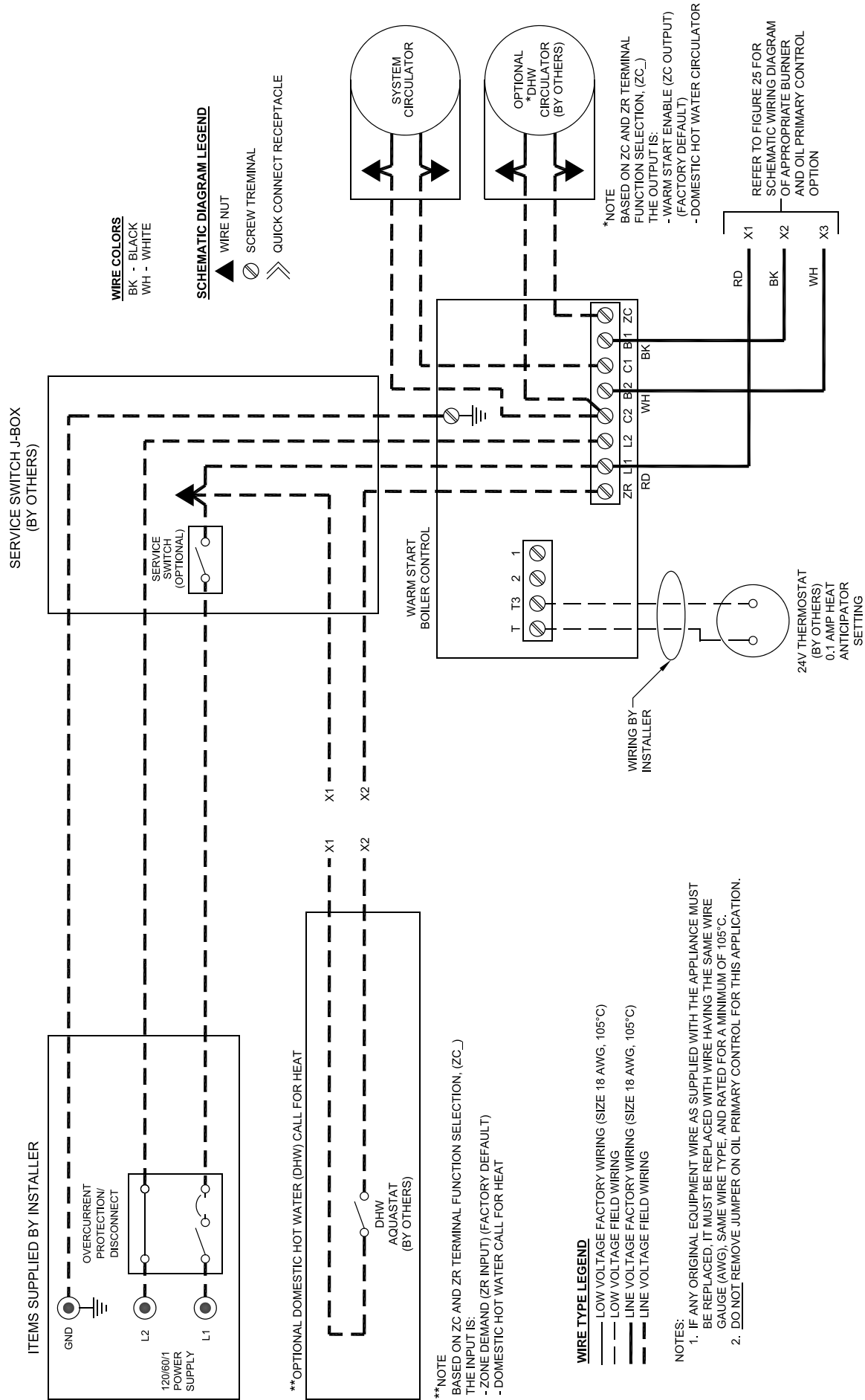

Figure 22: Schematic Wiring Diagram, with Tankless Heater, Warm Start Control (All Burners)

IV: ELECTRICAL (continued)

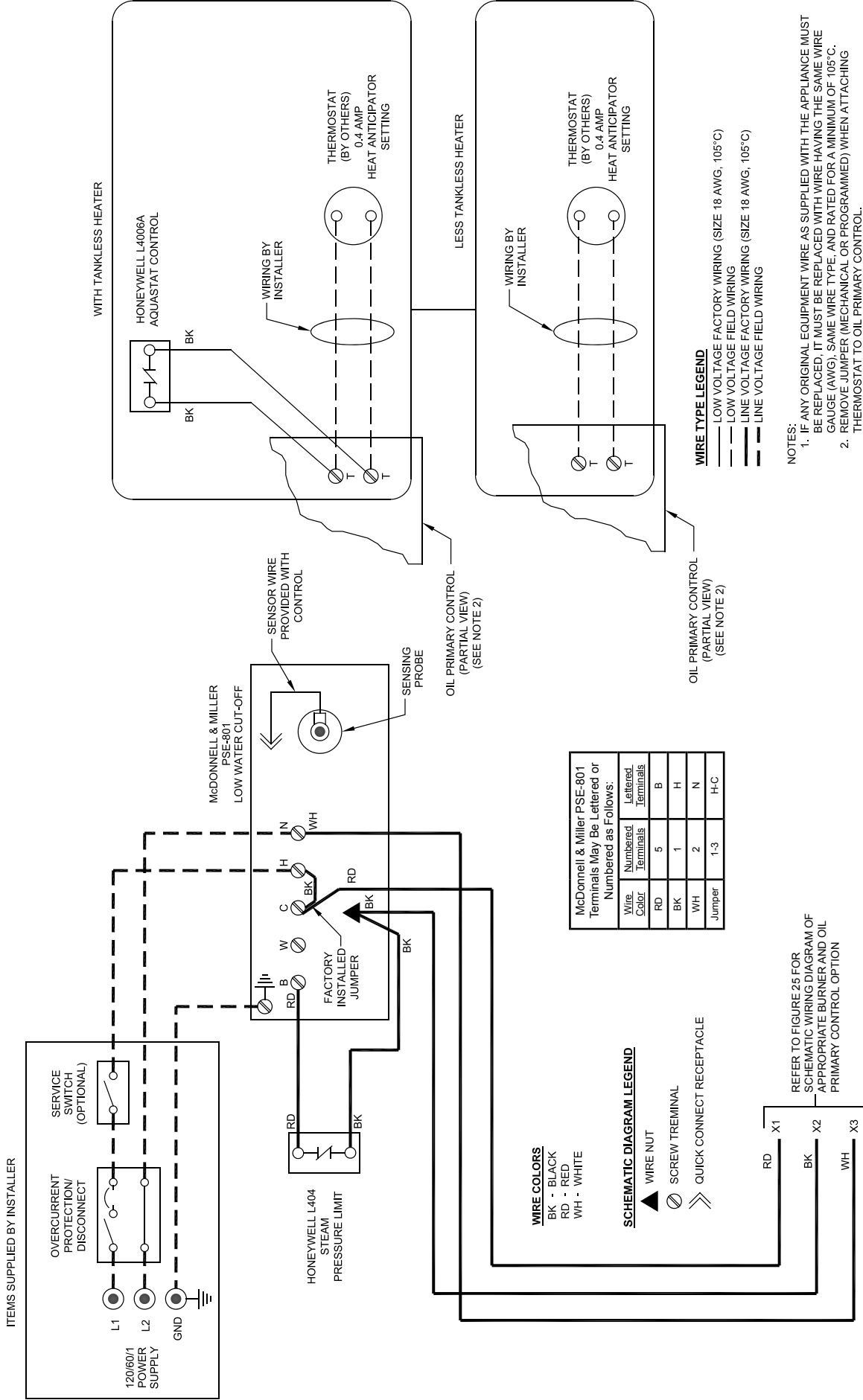
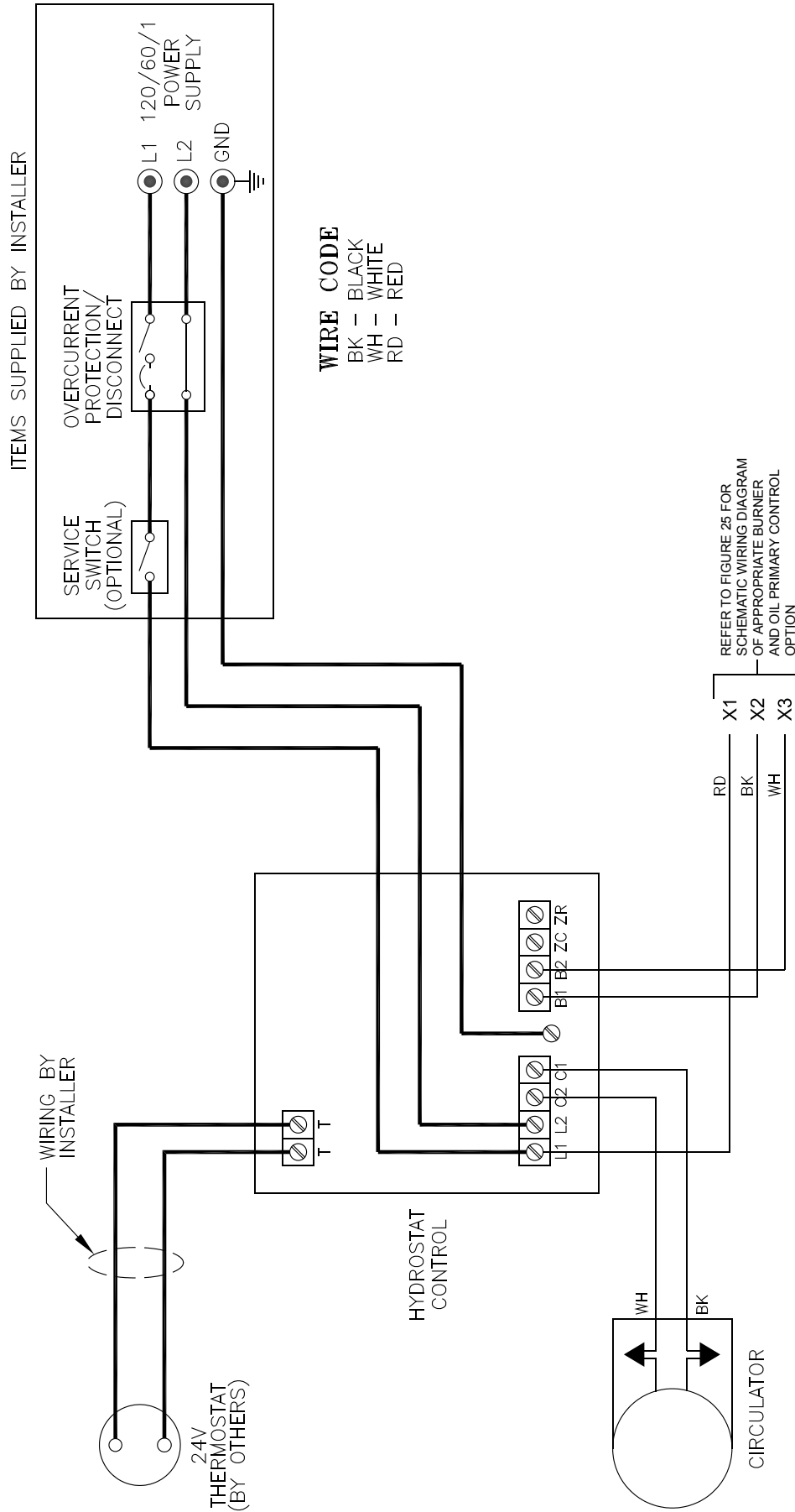

Figure 23: Schematic Wiring Diagram, Steam Boilers With or Without Tankless Heater, McDonnell & Miller PSE-801 Probe LWCO, Beckett AFG and Carlin EZ Burners

IV: ELECTRICAL (continued)



SCHEMATIC DIAGRAM LEGEND

- LINE VOLTAGE SIZE 14 AWG TYPE TW WIRE
- LINE VOLTAGE SIZE 18 AWG TYPE TW OR TEW/AWM WIRE - 105°C
- LOW VOLTAGE SIZE 18/2 AWG TYPE CL2X OR POWER LIMITED CIRCUIT CABLE - 75-105°
- ⊙ SCREW TERMINAL
- ▲ WIRE NUT

Figure 24: Schematic Wiring Diagram, Water Boilers with or without Tankless Heater, Hydrolevel HydroStat, All Burners

IV: ELECTRICAL (continued)

NOTE: APPLY THIS BURNER SCHEMATIC TO APPROPRIATE STEAM OR WATER BOILER CONTROL SCHEMATIC, REFER TO FIGURES 21 THRU 24

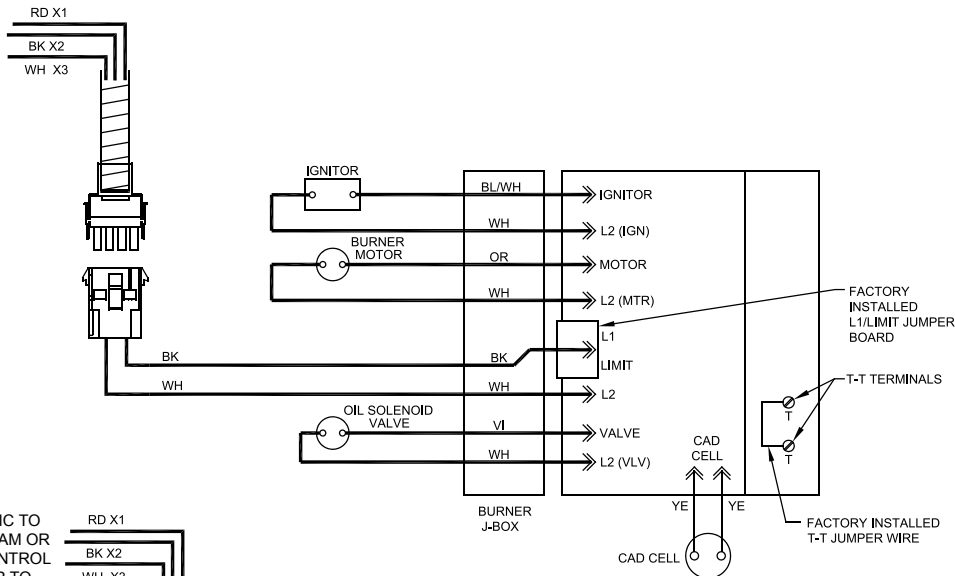

BECKETT AFG BURNER WITH GeniSys OIL PRIMARY CONTROL

SCHEMATIC DIAGRAM LEGEND

- ⊙ SCREW TERMINAL
- QUICK CONNECT RECEPTACLE

WIRE COLORS

- BK - BLACK
- BL/WH - BLUE W/ WHITE TRACER
- WH - WHITE
- VI - VIOLET
- YE - YELLOW
- OR - ORANGE
- RD - RED

WIRE TYPE LEGEND

- LOW VOLTAGE FACTORY WIRING (SIZE 18 AWG, 105°C)
- LOW VOLTAGE FIELD WIRING
- LINE VOLTAGE FACTORY WIRING (SIZE 18 AWG, 105°C)
- LINE VOLTAGE FIELD WIRING

NOTE: APPLY THIS BURNER SCHEMATIC TO APPROPRIATE STEAM OR WATER BOILER CONTROL SCHEMATIC, REFER TO FIGURES 21, 22 AND 24

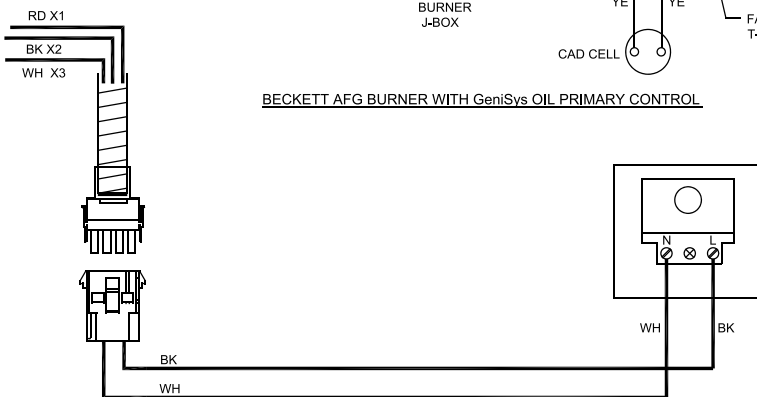

RIELLO 40 SERIES BURNER WITH RIELLO OIL PRIMARY CONTROL

NOTES:

1. IF ANY ORIGINAL EQUIPMENT WIRE AS SUPPLIED WITH THE APPLIANCE MUST BE REPLACED, IT MUST BE REPLACED WITH WIRE HAVING THE SAME WIRE GAUGE (AWG), SAME WIRE TYPE, AND RATED FOR A MINIMUM OF 105°C.

NOTE: APPLY THIS BURNER SCHEMATIC TO APPROPRIATE STEAM OR WATER BOILER CONTROL SCHEMATIC, REFER TO FIGURES 21 THRU 24

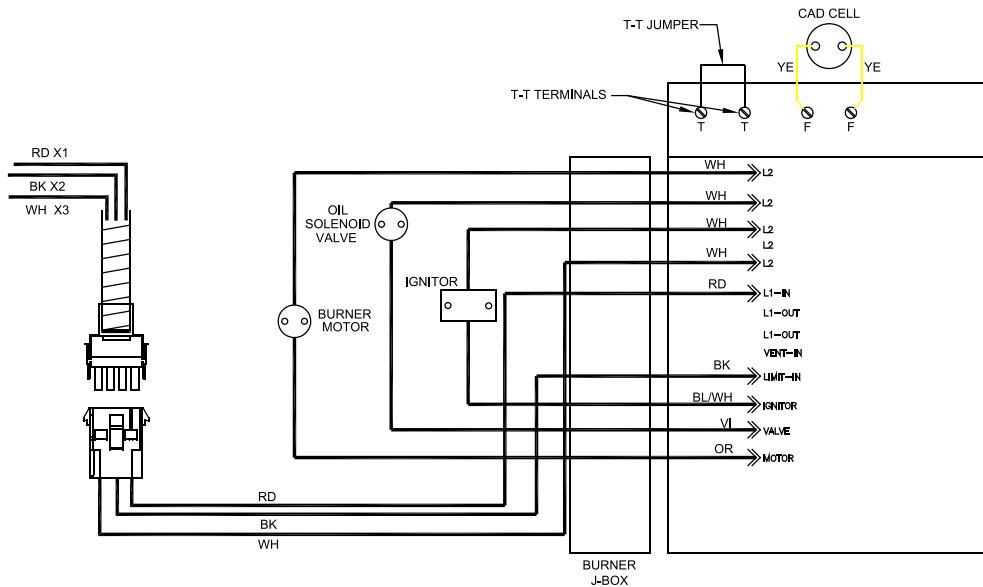

CARLIN EZ1, EZ2 & 102CRD BURNERS WITH CARLIN 70200 OIL PRIMARY CONTROL

Figure 25: Schematic Wiring Diagrams For All Burner Options w/Variou Oil Primary Controls

V: SYSTEM START-UP

WARNING

All boilers equipped with burner swing door have a potential hazard which can cause severe property damage, personal injury or loss of life if ignored. Before opening swing door, turn off service switch to boiler to prevent accidental firing of burner outside the combustion chamber. Be sure to tighten swing door fastener completely when service is completed.

A. ALWAYS INSPECT INSTALLATION BEFORE STARTING BURNER.

1. **Verify** that the venting, water piping, oil piping, and electrical system are installed properly. Refer to Installation Instructions contained in this manual.
2. **Confirm** all electrical, water and oil supplies are turned off at the source and that the vent is clear from obstructions.

WARNING

Completely read, understand and follow all instructions in this manual before attempting start up.

B. FILL HEATING SYSTEM WITH WATER.

NOTICE

It is important, especially in a steam system, to properly remove the oil and dirt from the system. Failure to clean the system can result in erratic water lines and surging.

Clean Heating System if boiler water or condensate return water is dirty or if erratic water lines or surging exist after a few days of boiler operation.

Refer to Maintenance and Service Instructions Section of this manual for proper cleaning instructions for steam and water boilers.

1. **Steam Boilers** — Fill boiler to normal water line. Refer to Figure 1C.
2. **Hot Water Boilers.** Fill entire heating system with water and vent air from system. Use the following procedure on a series loop or multi-zoned system installed as per Figures 12A and 12B, to remove air from system when filling:
 - a. Close full port ball valve in boiler system piping.
 - b. Isolate all zones by closing zone valves or shut-off valves in supply and return of each zone(s).
 - c. Attach a hose to vertical purge valve in boiler system piping.
(**Note** - Terminate hose in five gallon bucket at a suitable floor drain or outdoor area).
 - d. Starting with one zone at a time, open zone valve or shut-off valve in boiler supply and return piping.

- e. Open purge valve.
- f. Open shut-off valve in cold water supply piping located between the air scoop and expansion tank.
- g. Allow water to overflow from bucket until discharge from hose is bubble free for 30 seconds.
- h. When zone is completely purged of air, close zone valve or shut-off valve. Open zone valve to the next zone to be purged. Repeat this step until all zones have been purged. At completion, open all zone valves.
- i. Close purge valve, continue filling the system until the pressure gauge reads 12 psi. Close shut-off valve in cold water supply piping.

WARNING

The maximum operating pressure of this boiler is posted on the ASME Data Label located on the top of the boiler. Never exceed this pressure. **DO NOT** plug safety or relief valve.

NOTICE

If make-up water line is equipped with pressure reducing valve, system will automatically fill to 12 psi. Follow fill valve manufacturer's instructions.

- j. Open full port ball valve in boiler system piping.
- k. Remove hose from purge valve.
- l. Confirm that the boiler and system have no water leaks.

C. CHECK CONTROLS, WIRING AND BURNER

to be sure that all connections are tight and burner is rigid, that all electrical connections have been completed and fuses installed, and that oil tank is filled and oil lines have been tested.

D. ADJUST CONTROL SETTINGS with burner service switch turned "ON".

1. **Set Room Thermostat** about 10°F below room temperature.
2. **Press Red Reset Button** on front of burner cover (Beckett, Riello burners) or Oil Primary Control with burner cover removed. Hold button for one (1) second and release to reset primary control.

V: SYSTEM START-UP (continued)

3. Steam Boilers:

With an PA404A Pressure Limit - set cut-out pressure (MAIN scale) on the pressure limit for (1) PSI and differential pressure (DIFF.) for .5 PSI. These pressures may be varied to suit individual requirements of the system.

4. Steam Boilers with Tankless Domestic Water Heaters, set boiler water temperature dial on L4006 operating control at 190°F (max.). Set differential at 10°.

5. Water Boilers without Tankless Heaters, are equipped with an Intelligent Oil Boiler Control (Boiler Control). The Boiler Control is factory programmed with a High Limit setpoint of 180°F. The High Limit setpoint is adjustable between 140°F and 240°F. This temperature may be varied to suit the installation requirements.

High Limit Differential is factory programmed at 15°F and is adjustable between 10°F and 30°F.

6. Water Boilers with Tankless Heaters are equipped with a Warm Start Intelligent Oil Boiler Control (Warm Start Boiler Control). The Warm Start Boiler Control is factory programmed with a High Limit setpoint of 180°F. The High Limit setpoint is adjustable between 140°F and 240°F. High Limit Differential is factory programmed at 10°F. Additionally, the Warm Start Boiler Control is factory programmed with a Low Limit setpoint of 110°F. The Low Limit setpoint is adjustable between 110°F and 220°F. These temperatures may be varied to suit the installation requirements.

7. Checkout

Put the system into operation and observe at least one complete cycle to make sure that the controller operates properly. See Troubleshooting Section to use LED to assist in determining system operation.

E. ADJUST OIL BURNER BEFORE STARTING.

1. Check Burner Settings and readjust if necessary, see Burner Specifications, Tables 14A and 14B at rear of this manual.

2. Beckett Burners

- Inspect Beckett head setting on left side of burner housing by insuring the blue line MD(V1) or the line on the label MB(L1) are aligned, readjust if necessary. Refer to Figure 27 and Table 14A at the rear of this manual.
- Check burner air band and air shutter settings. Readjust if necessary, see Burner Specifications Table 14A at the rear of this manual.
- Open all oil line valves.**
- Attach a plastic hose to fuel pump vent fitting and provide a pan to catch the oil.

- Open Flame Observation Port cover** on burner swing door.

3. Riello Burners

- Inspect Riello head setting on left side of burner by reading the scale embossed on the housing cover. Refer to Figure 8.
- Inspect Riello burner air damper and turbulator setting. Readjust if necessary, see Table 14B at the rear of this manual.
- OPEN ALL OIL LINE VALVES.
- Provide a pan to catch oil.
- Remove pressure port/bleeder plug from fuel pump and install Riello Combination Pressure Gauge and Bleeder Valve Assembly.
- OPEN FLAME OBSERVATION PORT COVER on burner swing door.

CAUTION

Air Band is set for maximum input and must be readjusted prior to starting burner, if nozzle was changed to a lower firing rate.

4. Carlin Burners

- Inspect Carlin head setting on left side of burner to ensure that the proper head positioning bar matches the nozzle that is installed in drawer assembly. Replace bar if necessary.
- Change the factory air settings according to Table 14C (at rear of this manual)
- Open all oil line valves.**
- Attach a plastic hose to fuel pump vent fitting and provide a pan to catch the oil.
- Open flame observation port cover** on burner swing door.

F. START OIL BURNER.

- Open** vent fitting on fuel pump.
- Turn 'ON' Burner** service switch and allow burner to run until oil flows from vent fitting in a **solid** stream without air bubbles for approximately 10 seconds.
- Close** vent fitting and burner flame should start immediately after prepurge is completed. Prepurge prevents burner flame until 10 seconds has elapsed after initial power is applied to burner. During prepurge the motor and igniter will operate but the oil valve will remain closed. Refer to Oil Primary Control Instructions for more details.

V: SYSTEM START-UP (continued)

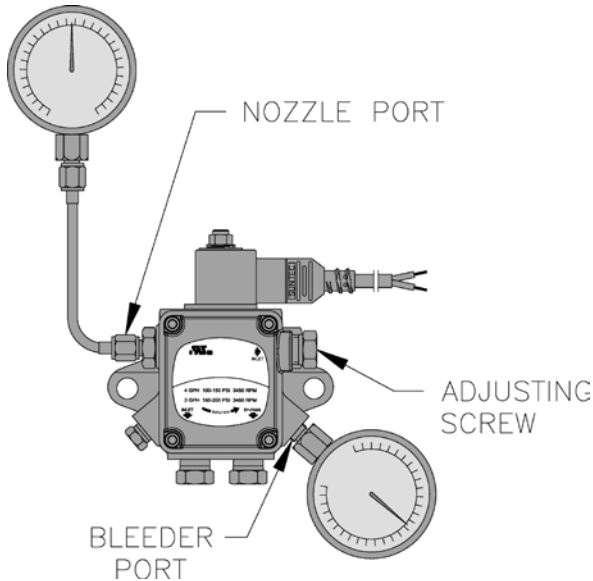

Figure 26: Adjusting Fuel Pump Pressure

4. Adjust oil pressure.

- When checking a fuel unit's operating pressure, a reliable pressure gauge may be installed in either the bleeder port or the nozzle port. Refer to Figure 26. Refer to Figure 9 for Riello burner.
- Locate oil pressure adjusting screw and turn screw to obtain proper pump pressure, refer to Tables 14A and 14B at the rear of this manual.
- To check the cutoff pressure, deadhead a reliable pressure gauge onto the copper connector tube attached to the nozzle port. Run the burner for a short period of time. Shut the burner off. The pressure should drop and hold.
- Remove the gauge and install bleeder port and/or reconnect the nozzle port line.

G. ADJUST OIL BURNER WHILE OPERATING. (FLAME PRESENT)

- Set room thermostat** about 10°F below room temperature.
- Press red reset button** on Oil Primary Control and release.
- Beckett Burners** - Readjust the head setting, only if necessary.
 - CL3-091 thru CL4-126:
Beckett MB(L1) Head burners have a fixed head which are non-adjustable.
 - CL4-175 thru CL5-280:
Beckett MD(V1) (variable) Head burners have the ability to control air by moving the head. It might be necessary to move the head forward or back one position at a time to optimize the smoke and CO₂ readings. See Figure 27 and Table 14A at the rear of this manual.

- Riello Burners** - Readjust the turbulator setting, only if necessary.
 - CL3 through CL5 (All Models)
Move the turbulator setting forward or back one position at a time to optimize the smoke and CO₂ readings. Refer to Figure 8 and Table 14B at the rear of this manual.
- Readjust the Head Setting**, only if necessary.
 - Carlin EZ-1HP and EZ-2HP burners use a head positioning bar to fix the head setting based on nozzle size. To adjust this setting, bar must be changed to the next larger or smaller bar available.
- Readjust the Air Damper Setting** (air Band/Air Shutter/Air Gate) on the burner for a light orange colored flame while the draft over the fire is $-0.02''$. Use a smoke tester and adjust air for minimum smoke (not to exceed #1) with a minimum of excess air. Make final check using suitable instrumentation to obtain a CO₂ of 11.5 to 12.5% with draft of $-0.02''$ (water gauge) in fire box. These settings will assure a safe and efficient operating condition. If the flame appears stringy instead of a solid fire, try another nozzle of the same type. Flame should be solid and compact. After all adjustments are made, recheck for a draft of $-0.02''$ over the fire.
- Only Readjust the Head/Turbulator Setting**, if necessary.
 - CL3 through CL5 (All Models)
Move the setting forward or back one position at a time to optimize the smoke and CO₂ readings.
 - Steps outlined in Paragraph 5 and 6 above must be repeated every time the Head/Turbulator or Air Damper Setting is readjusted.
- Turn "OFF" burner** and remove Riello Combination Pressure Gauge and Bleeder Valve Assembly. Install pressure port/bleeder plug and tighten. Start burner again.

WARNING

DO NOT loosen or remove any oil line fittings while burner is operating.

9. Flame Failure

The CL boiler controls operate the burner automatically. If for unknown reasons the burner ceases to fire and the reset button on the primary control has tripped, the burner has experienced ignition failure. Refer to Oil Primary Control features, Paragraph I, Step 2 of this Section and Section IX, Troubleshooting, Paragraph B. If the failure re-occurs, call your heating contractor immediately before pressing the reset button.

V: SYSTEM START-UP (continued)

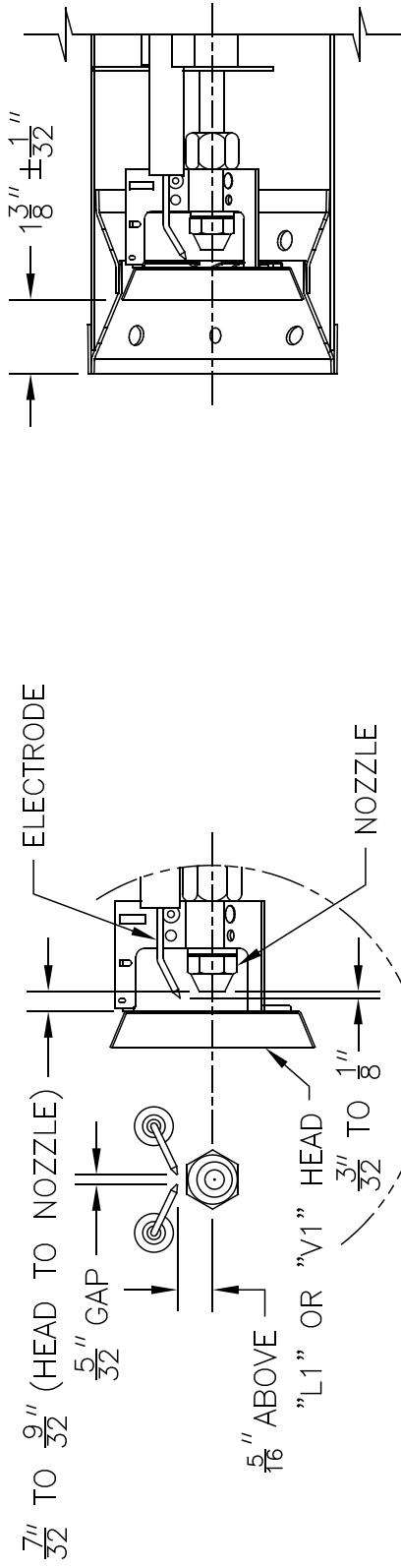

**ELECTRODE ADJUSTMENT
"L1" OR "V1" HEAD**

L1 HEAD

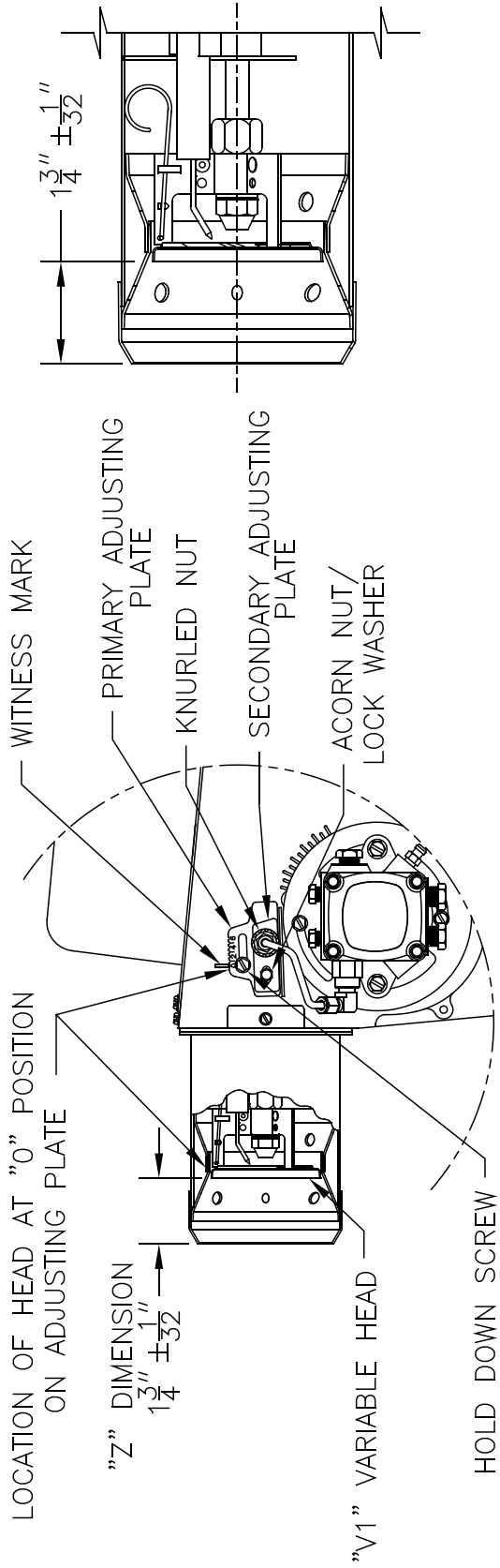

**HEAD SETTING (AT "0")
"V1" HEAD**

V1 HEAD

Figure 27: "L1" and "V1" Head Electrode Positioning and Gun Setting (Beckett AFG)

V: SYSTEM START-UP (continued)

WARNING

DO NOT attempt to start the burner when excess oil has accumulated, when the boiler is full of vapor, or when the combustion chamber is very hot.

10. **Cad Cell Location and Service.** The burner is supplied with a cadmium sulfide flame detector mounted at the factory, mounted on the bottom of the electronic ignitor. See Figure 28. To service cad cell or to replace the plug in portion, swing open the ignitor. After service is complete, be sure to fasten down the ignitor.

H. CHECK FOR CLEAN CUT OFF OF BURNER.

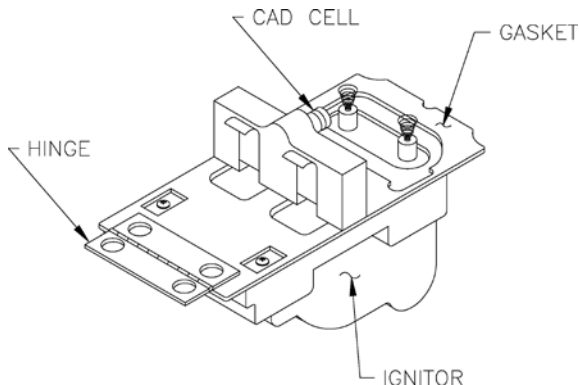

Figure 28: Cad Cell Location

1. **Air in the oil line** between fuel unit and nozzle will compress when burner is on and will expand when burner stops, causing oil to squirt from nozzle at low pressure as burner slows down and causing nozzle to drip after burner stops. Usually cycling the burner operation about 5 to 10 times will rid oil line of this air.
2. **If nozzle continues to drip**, repeat Paragraph H, Step 1 above. If this does not stop the dripping, remove cut-off valve and seat, and wipe both with a clean cloth until clean, then replace and readjust oil pressure. If dripping or after burn persist replace fuel pump.

I. TEST CONTROLS.

1. Check thermostat operation. Raise and lower thermostat setting as required to start and stop burner.

WARNING

Before installation of the boiler is considered complete, the operation of all boiler controls must be checked, particularly the primary control and high limit control.

2. **Verify Oil Primary Control features** using procedures outlined in Instructions furnished with control or instructions as follows:
 - a. **GeniSys 7505 Control Features**, see Figure 29.
 - i. The GeniSys 7505 is a microprocessor-based control. The indicator light provides diagnostic information for lockout, recycling and cad cell status. There is a manual reset button to exit the Lockout Mode.
 - ii. **Pump Priming Cycle:** To facilitate purging air from the oil lines and filters, the 7505 can be placed in a purge routine by:
 - After the burner starts, press and hold the reset button for 15 seconds until the yellow light turns on. This indicates that the button has been held long enough.
 - Release the reset button. The yellow light will turn off and the burner will start up again.
 - At burner start up, click the reset button while the igniter is till on. This will transition the control to a dedicated Pump Prime mode, during which the motor, igniter, and valve are powered for four (4) minutes. The yellow light will be on.

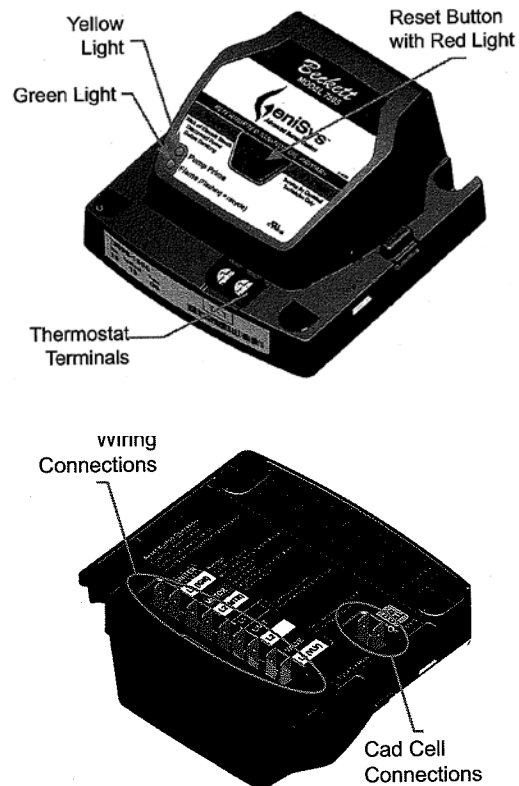

Figure 29: GeniSys 7505 Oil Primary Terminals, LED's and Reset Button

V: SYSTEM START-UP (continued)

- At the end of four (4) minutes, the yellow light will turn off and the control will automatically return to standby mode.
 - iii. Limited Recycle: This feature limits the number of recycle trials (for each call for heat) to a maximum of three trials. If the flame is lost three times and does not successfully satisfy a call for heat, the 7505 locks out.
 - iv. Limited Reset (Restricted Mode): In order to limit the accumulation of unburned oil in the combustion area, the control can only be reset three times. The reset count returns to zero each time a call for heat is successfully completed.
 - v. T-T Jumper: Select models have pre-installed T-T jumper. **DO NOT** remove jumper.
- Note:** **DO NOT** remove "T-T" jumper **unless** wiring diagram indicates a direct connection from thermostat and/or tankless heater aquastat control to the oil burner primary control's "T-T" terminal. Refer to appropriate wiring diagram, see Figure 21, 22, 23 or 24.
- vi. Diagnostic LED: The indicator light on oil primary control provides lockout, recycle and cad cell indications as follows:
 - Flashing at 1 Hz (½ second on, ½ second off): system is locked out or in Restricted Mode.
 - Flashing at ¼ Hz (2 seconds on, 2 seconds off): control is in Recycle Mode.
 - On: cad cell is sensing flame.
 - Off: cad cell is not sensing flame.
 - vii. Cad Cell Resistance Check: For proper operation it is important that the cad cell resistance is below 1600 ohms. During a normal call for heat, the cad cell leads can be unplugged from the control and the resistance measured with a meter in the conventional way.
Conduct these tests with flame present, see chart below.

Flame Detection Range
Normal (0 - 1600 ohms)
Limited (1600 ohms to lockout)

- b. Verify Oil Primary Control Features using procedures outlined in Carlin *Model EZ-1/2/3 Oil Burner-Instruction Manual* (Form "MNEZ123) for Operational details of, Electronic Oil Burner

Primary Control, Model 70200. Also refer to Trouble Shooting Oil Primary Control in this manual.

3. Check Oil Primary Control

CAUTION

Due to the potential hazard of line voltage, only a trained, experienced service technician should perform the following safety checks.

This control contains no field-serviceable parts. DO NOT attempt to take it apart. Replace entire control if operation is not as described.

- a. Preliminary Steps
 - Check wiring connections and power supply.
 - Make sure power is on to the controls.
 - Make sure limit control is closed.
 - Check contacts between ignitor and the electrodes.
 - Check the oil pump pressure.
 - Check the piping to the oil tank.
 - Check the oil nozzle, oil supply and oil filter.
- b. Check Safety Features
 - Safe Start:
 - Place a jumper across cad cell terminals.
 - Follow procedure to turn on burner. Burner must not start, indicator light turns on and control remains in Idle Mode.
 - Remove jumper.
 - c. Simulate Ignition or Flame Failure:
 - Follow procedure to turn on burner.
 - Check cad cell resistance. If resistance is below 1600 OHMS and burner runs beyond safety cut-out time, cad cell is good.
 - If safety switch shuts down burner and resistance is above 1600 OHMS, open line switch to boiler. Access cad cell under ignitor, clean face of cad cell and see that cell is securely in socket. Check gasket around perimeter of ignitor lid for proper seal. If gasket is missing or damaged, replace gasket. Room light can effect cad cell resistance. Reset safety switch.
 - Close line switch to boiler. If burner starts and runs beyond safety switch cut-off time, cell is good. If not, install new cell.
 - Close hand valve in oil supply line.
 - Failure occurs, device enters Recycle Mode.

V: SYSTEM START-UP (continued)

- Device tries to restart system after approximately 60 seconds.
 - After third Recycle Mode trial, safety switch locks out within safety switch timing indicated on label and control enters Restricted Mode. Ignition and motor stop and oil valves closes.
- d. Power Failure Check: After Flame is established, turn the power off to the control/ burner. The burner should shut down safely. When power is restored a normal ignition sequence should be started.

WARNING

Cad Cell Jumper must be removed after this check.

4. Check High Limit

- a. Adjust system thermostat(s) to highest setting.
- b. Allow burner to run until boiler water temperature exceeds high limit setting. The burner should shut down and circulators continue running.
- c. Allow the temperature to drop below control setting. The burner must restart.
- d. Boiler installation is not considered complete until this check has been made.

5. Check Low Water Cut-Off Control

a. Steam Boiler

Check Low Water Cut-off Control with water level at normal water line (see Figure 1C). Raise thermostat setting to allow burner to operate. Open boiler drain to allow water level to drop to bottom of sight glass until burner operation is shut-down by low water cut-off.

Close boiler drain and refill to normal water line. Burner should automatically restart during fill. Lower thermostat setting.

b. Water Boiler

Refer to Appendix "A" at the rear of this manual.

6. **Check operating control** on boiler applications equipped with tankless heater(s). With burner off, draw hot water until burner starts, then turn off hot water and check burner shut-down.

J. **IF CONTROLS MEET REQUIREMENT**

outlined in Paragraph I, allow boiler to operate for approximately 30 minute, confirm the boiler and system have no leaks.

K. **IF CONTROLS DO NOT MEET**

REQUIREMENTS outlined in Paragraphs I-1 thru I-6, replace control and repeat checkout procedures.

VI: OPERATING

TABLE 7: SEQUENCE OF OPERATION

Status Codes Displayed in SEt Mode		
SEt	Status	Description
1	Standby (burner off, pump off)	No call for heat detected
1	Standby (burner off, pump on)	Either condition is true: a. Call for heat detected and boiler temperature higher than operating setpoint. b. Call for heat detected and boiler temperature higher than 140 F and Pump Pre-Purge Time has not expired.
8	Running	The burner runs until the call for heat is satisfied.
17	Self Test	Control internal checking

A. WATER BOILERS SEQUENCE OF OPERATION

1. **Water Boilers Without Tankless Heaters (Cold Start), Sequence Of Operation:**
 - a. The CL Boiler is equipped with an Intelligent Oil Boiler Control (Cold Start Boiler Control). The boiler control replaces the traditional electronic aquastat and circulator relays and adds energy saving thermal purge features. Energy is saved by starting the circulator and delaying the burner start when there is residual heat available in the boiler.
 - b. The boiler's sequence of operation is shown as Status Codes on Boiler Control display. See Table 7 and Figure 30.
 - c. When the thermostat calls for heat the boiler control starts the system circulator and the thermal purge (circulator pre-purge time) begins. If the time is completed or boiler temperature is less than the Start Temperature (140 F default) the start sequence continues by energizing the oil primary to operate the following sequence: blower is started and operates for pre-purge time; spark is energized and fuel valve is opened for ignition trial time; burner fires until the thermostat is satisfied.
 - d. If the thermostat is not satisfied and the Operating Setpoint (SP) is reached the system circulator will continue to operate and the burner will stop. When the boiler water temperature drops below the setpoint less the differential setting the burner will restart.
 - e. After the thermostat is satisfied the burner and circulator are stopped.
 - f. When an indirect water heater aquastat call for heat is wired to the "ZR" terminal the Boiler Control starts a domestic hot water circulator connected to the "ZC" terminal and when the

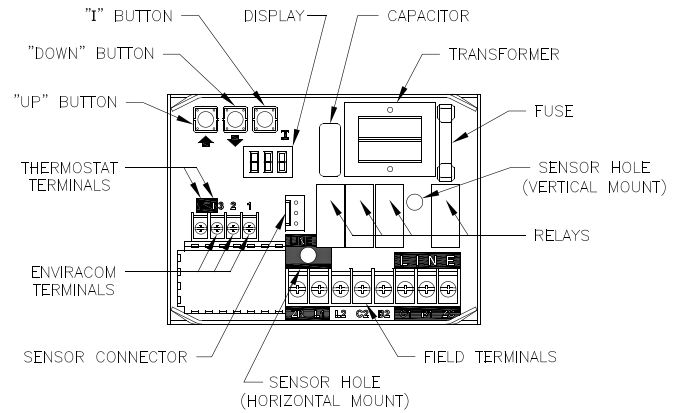

Figure 30: Intelligent Oil Boiler Control

- g. boiler temperature is less than Operating Setpoint (SP), the boiler control energizes the oil primary to turn on the burner without circulator pre-purge delay.
 - g. On burner start, if the CAD cell does not see flame within approximately 15 seconds, primary control will shut down the burner and enter into a lockout mode. A lockout is reset by pressing the reset button located on the primary control. If the flame is lost while the burner is firing, the primary control shuts down the burner, enters a 60 second recycle delay, and repeats the ignition sequence. If after three (3) trials for ignition, flame is not detected, primary control will enter into restricted mode. Restricted mode is reset by holding down the reset button for 15 seconds.
2. **Water Boilers with Tankless Heaters (Warm Start), Sequence Of Operation:**
 - a. The CL Boiler is equipped with a Warm Start Intelligent Oil Boiler Control (Warm Start Boiler Control). The Warm Start Boiler Control replaces the traditional high and low limit aquastat and circulator relays.
 - b. The boiler's sequence of operation is shown as Status Codes on Boiler Control display. See Table 7 and Figure 30.
 - c. When the thermostat calls for heat the boiler control starts the system circulator and the start sequence continues by energizing the oil primary to operate the following sequence: blower is started and operates for pre-purge time; spark is energized and fuel valve is opened for ignition trial time; burner fires until the thermostat is satisfied. Optionally, the thermal purge (circulator pre-purge time) maybe added adjusting the Circulator Pre-purge time parameter. This feature saves energy by starting the circulator and delaying the burner start when there is residual heat available in the boiler .

VI: OPERATING (continued)

- d. If the thermostat is not satisfied and the Operating Setpoint (SP) is reached the system circulator will continue to operate and the burner will stop. When the boiler water temperature drops below the setpoint less the differential setting the burner will restart.
- e. After the thermostat is satisfied the burner and circulator are stopped.
- f. The Warm Start Boiler Control also includes a low limit control function. When the boiler water temperature falls below the Low Limit Setpoint less the Low Limit Differential the “ZC” terminal and System Circulator outputs are de-energized and the oil primary is energized to start the burner. As temperature rises above the Low Limit Setpoint the burner is stopped, the “ZC” output is energized and the System Circulator is enabled to run in response to a call for heat.
- g. On burner start, if the CAD cell does not see flame within approximately 15 seconds, primary control will shut down the burner and enter into a lockout mode. A lockout is reset by pressing the reset button located on the primary control. If the flame is lost while the burner is firing, the primary control shuts down the burner, enters a 60 second recycle delay, and repeats the ignition sequence. If after three (3) trials for ignition, flame is not detected, primary control will enter into restricted mode. Restricted mode is reset by holding down the reset button for 15 seconds.

3. Using Boiler Control

The Boiler Control is located on front of boiler.

The Boiler Control display, along with Up ↑, Down ↓, and “I” keys may be used to view boiler operating status (Figure 31).

4. Viewing the Operating Mode Options

In operating mode the user may view (but not change) boiler operating status, settings and troubleshooting information. To view Boiler Control display information:

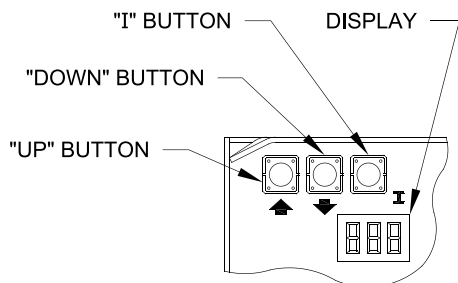
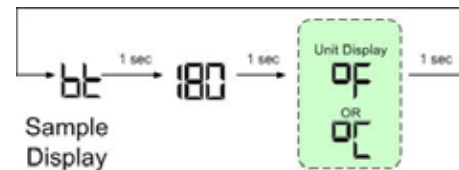

Figure 31: Boiler Control Key Function & Orientation

Press and release the “I” key on the Boiler Control to change from one parameter to the next. Each setting will alternately flash between the relevant display code and its corresponding value.

Operating Mode Options	
Status Numbers:	
<u>S</u> <u>E</u> <u>R</u>	1 Standby
	8 Running
	7 Self Test
<u>b</u> <u>t</u>	Boiler Temperature
<u>S</u> <u>P</u>	Operating Setpoint (Outdoor Reset)
<u>H</u> <u>L</u>	High Limit Setting
<u>H</u> <u>d</u> <u>F</u>	High Limit Differential
<u>L</u> <u>L</u>	Low Limit Setpoint (warm start only)
<u>L</u> <u>d</u> <u>F</u>	Low Limit Differential (warm start only)
<u>H</u> <u>r</u>	Heat Request Status
<u>d</u> <u>H</u>	DHW Request Status
<u>E</u> <u>r</u> <u>r</u>	Boiler Error

For example, when the “I” key is pressed on the Boiler Control until “bt” is displayed, it will then flash a three digit number (such as “180”) followed by either “F” (or “L”). This indicates that the boiler water temperature is 180°F. Other operating parameters display the information in a similar fashion.



Please note that in operating mode to hold the display on the value the user can press and hold either the Up ↑ or Down ↓ keys and the value will be continuously shown. This may be helpful in watching a value “live”.

5. Changing the Adjustable Parameters

To adjust parameters such as the High Limit Setpoint and High Limit Differential:

- a. Using the Boiler Control display, access the adjustment mode by pressing and holding the Up ↑, Down ↓, and “I” keys simultaneously for three (3) seconds. This procedure is intended to discourage unauthorized changes or accidental changes to limit settings.
- b. Press the “I” key to display available Adjustment Mode options. Select an option.

VI: OPERATING (continued)

Cold Start Boiler Control Adjustment Mode Options		
<i>HL</i> ₋	140-240°F	Adjust High Limit Setting
<i>HdF</i>	10-30°F	Adjust High Limit Differential
<i>ZC</i> ₋	<i>dh</i> , <i>Zr</i> or <i>ELL</i>	ZC and ZR Terminal Function
<i>Or</i> ₋	0-10 minutes	Pump Overrun Time
<i>PP</i> ₋	2-20 minutes	Pump Pre-purge Time
<i>St</i> ₋	140 - 180°F	Start Temperature
<i>Pt</i> ₋	<i>On</i> or <i>OFF</i>	Priority Time
<i>F-C</i>	<i>F</i> or <i>C</i>	Select degrees F or C Mode
<i>bAc</i>		Back to Operating Mode

Warm Start Boiler Control Adjustment Mode Options		
<i>HL</i> ₋	140-240°F	Adjust High Limit Setting
<i>LL</i> ₋	110-220°F	Adjust Low Limit Setting
<i>LdF</i>	10-25°F	Adjust Low Limit Differential Setting
<i>ZC</i> ₋	<i>Zr</i> or <i>dh</i>	ZC and ZR Terminal Function
<i>Or</i> ₋	0-10 minutes	Pump Overrun Time
<i>PP</i> ₋	0-20 minutes	Pump Pre-purge Time
<i>St</i> ₋	140 - 180°F	Start Temperature
<i>Pt</i> ₋	<i>On</i> or <i>OFF</i>	Priority Time
<i>F-C</i>	<i>F</i> or <i>C</i>	Select degrees F or C Mode
<i>bAc</i>		Back to Operating Mode

- c. Press the Up \uparrow and Down \downarrow keys to adjust the displayed setpoint to the desired value.
- d. To return to the normal operating mode from the Adjustment Mode, when the "*bAc*" option is displayed, press either the Up \uparrow or Down \downarrow key. If no keys are pressed, after five (5) minutes the Boiler Control will automatically return to the Operating Mode.

6. More Information about Adjustable Parameters

- a. High Limit (*HL*₋)
The Boiler Control is factory programmed with a High Limit Setpoint of 180°F. The boiler turns "off" when the boiler water temperature (*bT*) is above this value. The High Limit setpoint is adjustable between 140° and 240°F. The Operating Setpoint (*SP*) will equal the High Limit Setpoint.
- b. High Limit Differential (*HdF*)
 - i. The Cold Start Boiler Control is factory programmed with a Differential of 15°F. The Differential is the number of degrees the boiler temperature must decrease below the Operating Setpoint before the boiler can restart. The differential is adjustable between 10° and 30°F.
 - ii. On Warm Start Boiler Control the High Limit Differential is not adjustable and is fixed at 10°F.

c. Low Limit (*LL*₋)

The Warm Start Boiler Control is factory programmed with a Low Limit Setpoint of 110°F. On falling temperature the boiler turns "on" and the "ZC" terminal and System Circulator outputs are de-energized when the boiler temperature is less than the Low Limit Setpoint less the differential. On a rising temperature when the boiler temperature is above the Low Limit Setpoint the boiler turns "off", the "ZC" terminal output is energized and the System circulator is enabled to respond to a call for heat. The Low Limit Setpoint is adjustable between 110°F and 220°F.

d. Low Limit Differential (*LdF*)

The Warm Start Boiler Control is factory programmed with a Low Limit Differential Setpoint of 10°F. The Low Limit Differential is the number of degrees the boiler temperature must decrease below the Low Limit Setpoint before the Warm Start Boiler Control takes actions to warm the boiler. These actions include starting the burner and stopping water flow through the boiler. The Low Limit Differential is adjustable between 10°F and 25°F.

e. Circulator Overrun Time (*Or*₋)

Circulator Overrun Time (also called "circulator off delay" or "circulator post purge") continues circulator operation after a call for heat has ended, sending excess heat from the boiler into the priority zone. Ensure system piping and zone panel settings allow water flow to the priority zone after the call for heat ends. The Circulator Overrun Time has a factor setting of 0 minutes and is field adjustable between 0 and 10 minutes.

f. Circulator Pre-Purge Time (*PP*₋)

When the boiler is warm [boiler water temperature higher than 140°F (adjustable using Start Temperature parameter)] and there is a thermostat call for heat, the system circulator is started and boiler firing is delayed pre-purge minutes. If the temperature drops below 140°F or there is a DHW Call for Heat the boiler is started without delay. Additionally, the boiler is started without delay if the thermostat call for heat is initiated when the boiler water temperature is less than 140°F. This feature helps save energy by satisfying home heating needs with residual boiler heat rather than cycling the boiler. The Circulator Pre-purge time has a factory setting of 2 minutes and is field adjustable between 2 and 20 minutes. Refer to Table 8.

The Warm Start Boiler Control Pre-purge Time is factor set to 0 minutes.

VI: OPERATING (continued)

TABLE 8: CIRCULATOR PRE-PURGE TIME EXAMPLE, PARAMETER PP_ = 2 MINUTES

Call for Heat	ZC and ZR Terminal Function ($\mathcal{Z}\mathcal{L}_-$)	Boiler Temp.	Boiler Status, (B1 Output)
TT= on	--	< 140	Start with no delay
TT = on	--	>140	Start after 2 minute delay
ZR = on	$\mathcal{Z}\mathcal{L}_- = \mathcal{Z}r$	<140	Start with no delay
ZR = on	$\mathcal{Z}\mathcal{L}_- = \mathcal{Z}r$	>140	Start after 2 minute delay
ZR = on	$\mathcal{Z}\mathcal{L}_- = dH$	<140	Start with no delay
ZR = on	$\mathcal{Z}\mathcal{L}_- = dH$	>140	Start with no delay

g. Start Temperature ($\mathcal{S}\mathcal{L}_-$)

The amount of “Heat available” is calculated by taking the difference between measured boiler water temperature and the Start Temperature setting. Useful “Heat Available” is dependent on the type of heating emitter installed in the home. Heat emitters require a certain minimum temperature to operate effectively. Our default settings reflect cast iron radiators. Fan Coils may require a start temperature setting of 180°F or 160°F before providing heat to the home. The Start Temperature has a factory setting of 140°F and is field adjustable between 140°F and 180°F.

h. Priority Time ($\mathcal{P}\mathcal{L}_-$)

When the Priority Time parameter is set to “on” and Domestic Hot Water (DHW) call for heat is “on” the DHW demand will take “Priority” over home heating demand and the system circulator will be forced “off”. Priority Time ends and the system circulator is released to service home heating demand when Domestic Hot Water call for heat is over. When Priority Time parameter is set to “Off” the DHW call for heat does not force “off” the system circulator. The Priority Time has a factory setting of “On” and is field adjustable between “On” and “Off” Refer to Table 9.

i. ZC and ZR Terminal Function ($\mathcal{Z}\mathcal{L}_-$)

The boiler control allows configuration of the ZC output functionality to help the CL integrate into each installation more effectively. The ZC output can be connected to a domestic hot water circulator or a second heating zone circulator or be used to enable pumps in a warm start application. These applications are selected as follows:

i. When $\mathcal{Z}\mathcal{L}_-$ is set equal to Domestic Hot Water Demand (dH)

When there is an Indirect Water Heater (IWH) the boiler control provides a “ZR” input terminal for the IWH Aquastat and “ZC” output

terminal for the DHW Circulator. When there is a DHW call for heat, the System Circulator is “forced off”, the DHW Circulator terminal is energized and the circulator pre-purge time delay control logic is bypassed to allow the boiler to fire without delay. When DHW demand ends the System Circulator “force off” is removed, the circulator can respond normally, and the DHW Circulator is de-energized. The DHW call for heat is detected by a voltage on to the "ZR" terminal. When a Priority Time parameter is set to “off” the System Circulator is not forced off for a DHW call for heat. Refer to Table 9.

TABLE 9: DOMESTIC HOT WATER DEMAND, (PARAMETER $\mathcal{Z}\mathcal{L}_- = dH$)

Call for Heat		Priority Time ($\mathcal{P}\mathcal{L}_-$)	Circulator Status	
T-T Input	ZR Input		System Circulator Output	DHW Circulator ZC Output
on	off	On	on	off
on	on	On	off	on
off	on	On	off	on
on	off	OFF	on	off
on	on	OFF	on	on
off	on	OFF	off	on

ii. When $\mathcal{Z}\mathcal{L}_-$ is set equal to Zone Request ($\mathcal{Z}r$)

When there is no IWH the Cold Start Boiler Control “ZC” output may be configured to control a second heating zone. This is particularly helpful when the home uses only two heating zones. The boiler control replaces the need for a two circulator zone panel. When DHW Terminal Function (dH_-) is set to $\mathcal{Z}r$ the boiler control’s two circulator outputs are used to control two independent heating zones. Refer to Table 10. A "TT" input causes a call for heat and energizes the System Circulator output to service heating zone 1. A second zone’s thermostat may be wired to the "ZR" input to energize heating zone 2 circulator wired to the "ZC" output. Both outputs function independently, "TT" input controls only the System Circulator output and the "ZR" input controls only the "ZC" output. Both inputs cause a boiler call for heat.

The Warm Start Boiler Control with $\mathcal{Z}\mathcal{L}_-$ set equal to Zone Request ($\mathcal{Z}r$) energizes the "ZC" terminal while the boiler is warm as described earlier in this section (refer to Paragraph A.2,f). The "ZR" input is a call for heat that starts the boiler.

VI: OPERATING (continued)

TABLE 10: ZONE REQUEST, PARAMETER $zC = zr$

Call for Heat		Circulator Status	
T-T Input	ZR Input	C1 Output	ZC Output
off	off	off	off
on	off	on	off
on	on	on	on
off	on	off	on

iii. External Low Limit, Parameter $zC = ELL$

The Cold Start Boiler Control is capable of functioning as a warm start control when external limit control is installed that closes a contact when boiler water temperature falls below a setpoint. When an external limit contact closes (boiler water is cold) the boiler is started and the "ZC" and "C1" output terminals are de-energized. When the "ZR" terminal is de-energized (boiler water temperature is above setpoint) the call for heat is ended and the "C1" terminal is released to operation and the "ZC" terminal is energized. An External Low Limit Request is detected by sensing a voltage on the "ZR" terminal. The Warm Start Boiler Control does not have the External Low Limit Option. Refer to Table 11.

7. HydroStat 3250 Plus Sequence of Operation
 - a. Refer to the HydroStat Instructions (P/N 104145-01) for all operational instructions.
 2. Refer to the "IMPORTANT" notice below.

B. STEAM BOILERS SEQUENCE OF OPERATION

Upon a thermostat call for heat, when provided, the Oil Primary Control is energized when the steam pressure is below the L404F Pressure Limit and water level is above the Low Water Cut-Off. When energized the Oil Primary Control starts the burner as follows; blower is started and operates for a pre-purge time; spark is energized and

TABLE 11: EXTERNAL LOW LIMIT, PARAMETER $zC = ELL$

Call for Heat		Circulator Status	
T-T Input	ZR Input	C1 Output	ZC Output
off	off	off	on
on	off	on	on
on	on	off	off
off	on	off	off

fuel valve is opened for ignition trail time; the fuel valve remains open when flame is proven. The burner fires until the thermostat is satisfied or the Pressure Limit setting is reached. The Oil Primary Control stops the burner by closing the fuel valve and operating the blower for post-purge time. Upon a drop in pressure, steam pressure below the L404F Pressure Limit, the burner will re-start if the thermostat is still calling for heat. When there is a tankless heater included and there is no demand for heat, the L4006A operating control will maintain the boiler water temperature at the selected setting for proper operation of the domestic water heater.

The probe low water cut-off will shut down the burner after a 10 second delay, if the water level in the boiler drops below the probe level. If the water level is too low the burner will not be allowed to restart. The low water cut-off will reset and restart the burner with a call for heat 30 seconds after the water is returned to its normal level. On burner start, if the CAD cell does not see flame within approximately 15 seconds, primary control will shut down the burner and enter into a lockout mode. A lockout is reset by pressing the reset button located on the primary control. If the flame is lost while the burner is firing, the primary control shuts down the burner, enters a 60 second recycle delay, and repeats the ignition sequence. If after three (3) trials for ignition, flame is not detected, primary control will enter into restricted mode. Restricted mode is reset by holding down the reset button for 15 seconds.

IMPORTANT

This boiler is equipped with a feature that saves energy by reducing the boiler water temperature as the heating load decreases. This feature is equipped with an override which is provided primarily to prevent the use of an external energy management system that serves the same function. THIS OVERRIDE MUST NOT BE USED UNLESS AT LEAST ONE OF THE FOLLOWING CONDITIONS IS TRUE:

- An external energy management system is installed that reduces the boiler water temperature as the heating load decreases.
- This boiler is not used for any space heating.
- This boiler is part of a modular or multiple boiler system having a total input of 300,000 BTU/HR or greater.
- This boiler is equipped with a tankless coil.

VII: MAINTENANCE AND SERVICE INSTRUCTIONS

A. MAINTENANCE OF LOW WATER CUT-OFF DEVICES

WARNING

Probe and float type low water cut-off devices require annual inspection and maintenance.

1. **Although** these devices are solid state in their operation, the probe is exposed to possible contamination in the boiler water and subject to fouling.
2. **It is important** to physically remove the probe from the boiler tapping annually and inspect that probe for accumulation of scale or sediment.
3. **Follow these steps** to inspect, clean and/or replace the probe:
 - a. Turn off electric service to the boiler.
 - b. Drain boiler water to a level below the tapping for the probe.

DANGER

Assure that the boiler is at zero pressure before removing the LWCO probe. **DO NOT** rely on the pressure gauge to indicate that the boiler is at zero pressure. Open the safety valve to relieve all internal pressure prior to proceeding. Safety valve discharge piping must be piped such that the potential for burns is eliminated.

- c. Disconnect wiring connections between the low water cut-off control and the probe.
- d. Remove the low water cut-off control from the probe.
- e. Unscrew the probe from the boiler tapping.
- f. Inspect that portion of the probe that is exposed to the boiler water for a scale or sediment buildup.
- g. Light deposits may be removed by wiping the probe with a damp cloth. Wiping the probe with a cloth soaked in vinegar will remove more tenacious lime deposits. The most stubborn deposits may be removed from the probe by using a diluted amount, 3 parts of water to 1 part of phosphoric acid (H_2PO_4).

CAUTION

Exercise caution when handling phosphoric acid and follow the instruction label on its container.

- h. Clean the pipe threads of the probe to remove old, hardened pipe dope and other foreign matter.
- i. Apply a moderate amount of good quality pipe dope to the pipe threads on the probe, leaving the two end threads bare. **DO NOT** use PTFE (Teflon) tape.
- j. Screw the probe into the boiler tapping.
- k. Mount the low water cut-off control on the probe.
- l. Reconnect the control to probe wiring.
- m. Fill the boiler to its normal waterline.
- n. Add boiler water treatment compound as needed (refer to Paragraph B.).
- o. Restore electric service to the boiler.
- p. Fire burner to bring the water in the boiler to a boil to drive off free oxygen.
- q. **WARNING — BEFORE RETURNING BOILER TO SERVICE:** Follow the low water cut-off check out procedure in Section V "System Start-Up", Paragraph I, Step 5.

B. BOILER AND SYSTEM CLEANING INSTRUCTIONS FOR TROUBLE FREE OPERATION.

1. Steam Boilers:

- a. Oil, greases & sediments which accumulate in a new boiler and piping must be removed from the system in order to prevent an unsteady water line and carry over of the water into the supply main above boiler.

Operate the boiler with steam in the entire system for a few days allowing the condensate to return to the boiler. If the condensate can temporarily be wasted, operate boiler only for the length of time it takes for condensate to run clear. If the latter cannot be achieved or if the condensate is returned to the boiler, boil out the boiler using the SURFACE BLOW-OFF connection.

- i. Drain boiler until 1" of water is visible in gauge glass. Run temporary 1½" NPT pipe line from the surface blow-off connection to an open drain or some other location where hot water may be discharged safely. **DO NOT** install valve in this line.
- ii. Drain about 5 gallons of hot water from boiler into a container and dissolve into it an appropriate amount of recommended boil out compound. Remove safety valve & add solution to boiler water thru exposed tapping using a funnel.

VII: MAINTENANCE AND SERVICE INSTRUCTIONS (continued)

NOTICE

Check with local authorities or consult local water treatment services for acceptable chemical cleaning compounds.

- iii.* Start burner and operate sufficiently to boil the water without producing steam pressure. Boil for about 5 hours. Open boiler feed pipe sufficiently to permit a steady trickle of water from the surface blow-off pipe. Continue this slow boiling and trickle of overflow for several hours until the water coming from the overflow is clear.
 - iv.* Stop burner and drain boiler in a manner and to a location that hot water can be discharged with safety.
 - v.* Refill boiler to normal water line. If water in gauge glass does not appear to be clear, repeat steps (*i.* thru *iii.*) and boil out the boiler for a longer time.
 - b. Low pressure steam boilers such as the CL Series should be maintained with appropriate water treatment compounds. Add suitable water treatment compounds as recommended by your qualified water treatment company.
 - c. Remove temporary surface blow-off piping, plug tapping and reinstall safety valve. Boil or bring water temperature to 180°F promptly in order to drive off the dissolved gases in the fresh water.
 - d. If unsteady water line, foaming or priming persist, install gate valve in Hartford Loop and drain valves in return main and at boiler as shown in Figure 13 and proceed as follows:
 - i.* Connect hoses from drain valves to floor drain. Close gate valve in Hartford Loop and open drain valve in return main. Fill boiler to normal water level, turn on oil burner and operate boiler at this water level for at least 30 minutes after the condensate begins to run hot, then turn off burner.

Close all radiator valves. Remove all supply main air valves and plug the openings in supply main.
 - ii.* Draw about 5 gallons of hot water from boiler into a container and dissolve into it the appropriate amount of a recommended boilout compound. Remove safety valve from boiler and pour this solution into boiler, then reinstall safety valve.
 - iii.* Turn on oil burner and keep operating while feeding water to boiler slowly. This will raise water level in boiler slowly so that water will be boiling hot and will rise slowly into supply main and back through return main, flowing from drain hose at about 180°F. Continue until water runs clear from drain hose for at least 30 minutes.
 - iv.* Stop feeding water to boiler but continue operating oil burner until excess water in boiler flows out through supply main and water lowers (by steaming) until it reaches normal level in boiler. Turn off oil burner. Drain boiler. Open all radiator valves. Reinstall all supply main air valves. Open gate valve in Hartford Loop.
 - v.* When boiler has cooled down sufficiently (crown sheet of sections are not too hot to touch), close the drain valves at boiler and in return main and feed water slowly up to normal level in boiler. Turn on oil burner and allow boiler to steam for 10 minutes, then turn off burner. Draw off one quart of water from bottom gauge glass fitting and discard. Draw off another quart sample and if this sample is not clear, repeat the cycle of draining the boiler and return main and refilling the boiler until sample is clear.
 - vi.* If the boiler water becomes dirty again at a later date due to additional sediment loosened up in the piping, close gate valve in Hartford Loop, open drain valve in return main, turn on oil burner and allow Condensate to flow to drain until it has run clear for at least 30 minutes while feeding water to boiler so as to maintain normal water level. Turn off oil burner, drain boiler, open gate valve in Hartford Loop, then repeat the full "Boiler and System Cleaning" procedure outlined in Paragraph B starting on Page 43.
- e. Make pH or Alkalinity Test.

After boiler and system have been cleaned and refilled as previously described, test the pH of the water in the system. This can easily be done by drawing a small sample of boiler water and testing with hydrion paper which is used in the same manner as litmus paper, except it gives specific readings. A color chart on the side of the small hydrion dispenser gives the reading in pH. Hydrion paper is inexpensive and obtainable from any chemical supply house or through your local druggist. The pH should be higher than 7, but lower than 11. Add some of the washout chemical (caustic soda), if necessary, to bring the pH within the specified range.
- f. Boiler is now ready to be put into service.

VII: MAINTENANCE AND SERVICE INSTRUCTIONS (continued)

2. Water Boilers:

a. Filling of boiler and system.

General — In a hot water heating system, the boiler and entire system (other than the expansion tank) must be full of water for satisfactory operation. Water should be added to the system until the boiler pressure gauge registers 12 psi. To insure that the system is full, water should come out of all air vents when opened.

b. Boiling out of boiler and system. The oil and grease which accumulate in a new hot water boiler can be washed out in the following manner:

- i. Remove relief valve using extreme care to avoid damaging it.
- ii. Add an appropriate amount of recommended boil out compound.
- iii. Replace relief valve.
- iv. Fill the entire system with water.
- v. Start firing the boiler.
- vi. Circulate the water through the entire system.
- vii. Vent the system, including the radiation.
- viii. Allow boiler water to reach operating temperature, if possible.
- ix. Continue to circulate the water for a few hours.
- x. Stop firing the boiler.
- xi. Drain the system in a manner and to a location that hot water can be discharged with safety.
- xii. Remove plugs from all available returns and wash the water side of the boiler as thoroughly as possible, using a high-pressure water stream.
- xiii. Refill the system with fresh water.

c. Add appropriate boiler water treatment compounds as recommended by your qualified water treatment company.

d. Make pH or Alkalinity Test.

After boiler and system have been cleaned and refilled as previously described, test the pH of the water in the system. This can easily be done by drawing a small sample of boiler water and testing with hydriion paper which is used in the same manner as litmus paper, except it gives specific readings. A color chart on the side of the small hydriion dispenser gives the reading pH. Hydriion paper is inexpensive and obtainable from any chemical supply house or through your local druggist. The pH should be higher than

7 but lower than 11. Add some of the washout chemical (caustic soda), if necessary, to bring the PH within the specified range.

e. Boiler is now ready to be put into service.

3. Excessive Make-up Water

A leaky system will increase the volume of make-up water supplied to the boiler, which can significantly shorten the life of the boiler. Entrained in make-up water are dissolved minerals, salts and oxygen. When the fresh, cool make-up water is heated in the boiler, the minerals fall out as sediment, the salts coat the inside of the boiler, and the oxygen escapes as a gas. The accumulation of sediment eventually isolates the water from contacting the cast iron. When this happens the cast iron in that area gets extremely hot and eventually cracks. The presence of free oxygen or chloride salts in the boiler corrodes the cast iron from the inside. More make-up water and higher concentrations of contaminants damage the boiler sooner. Our warranty does not cover corrosion and sediment-related damage. Clearly it is in everyone's best interest to prevent this type of failure. You can do your part by ensuring that your system is leak-free, keeping leakage to less than 2 percent of the boiler water volume each month.

IMPORTANT

IF, DURING NORMAL OPERATION, IT IS NECESSARY TO ADD MORE WATER THAN INDICATED BELOW, CONSULT A QUALIFIED SERVICE TECHNICIAN TO CHECK YOUR SYSTEM FOR LEAKS.

Model No.	Gallons Per Month	Gallons Per Year
CL3	0.3	4
CL4	0.4	5
CL5	0.5	6

C. ATTENTION TO BOILER WHILE NOT IN OPERATION

1. Important

If boiler is not used during winter time, it must be fully drained to prevent freeze damage.

2. Spray inside surfaces with light lubricating or crankcase oil using gun with extended stem so as to reach all corners.

3. With steam boilers, at end of season add sufficient water to fill boiler to top of water column and leave it that way until fall when water should be drained

VII: MAINTENANCE AND SERVICE INSTRUCTIONS (continued)

again to proper level. If, at this time, boiler water is dirty, drain water, flush out boiler, and refill with clean water to prescribed water level.

4. Always keep the manual fuel supply valve shut off if the burner is shut down for an extended period of time.
5. To recondition the heating system in the fall season after a prolonged shut down, follow the instructions outlined in Section V, Paragraphs A through K.

WARNING

This boiler contains controls which may cause the boiler to shut down and not restart without service. If damage due to frozen pipes is a possibility, the heating system should not be left unattended in cold weather; or appropriate safeguards and alarms should be installed on the heating system to prevent damage if the boiler is inoperative.

VIII: BOILER CLEANING

WARNING

All boiler cleaning must be completed with burner service switch turned off.

A. CLEAN THE FLUEWAYS (SEE FIGURE 32).

1. Disconnect oil line(s) and remove burner and burner mounting plate. See Figures 1A thru 1C.
2. Lay protective cloth or plastic over combustion chamber blanket.
3. Remove the smokepipe as necessary to gain access to the boiler canopy.
4. Remove the jacket top panels.
5. Remove the canopy being careful not to damage the cerafelt gasket.
6. Using a 1¼" diameter wire or fibre bristle brush (30" handle) clean the flueways. Brush from the top using diagonal strokes for best results. **DO NOT** allow brush to strike the target wall or liner in the chamber.

B. CLEAN TOP OF BOILER SECTIONS.

1. Brush and vacuum the tops of the boiler sections.

C. CLEAN THE FIREBOX.

1. Using wire or fibre bristle brush, clean crown of boiler and inside of water legs. **DO NOT** allow brush to strike target wall or blanket in the combustion chamber.

- D. AFTER CLEANING,** remove protective cloth with debris and vacuum as necessary, but be careful not to damage blanket. Inspect target wall, combustion chamber blanket and burner mounting plate insulation for signs of damage. If damaged, replace as needed.

E. REASSEMBLE BOILER.

CAUTION: DO NOT start the burner unless canopy, smokepipe and burner swing door are secured in place.

1. Install the canopy taking care to align the gaskets without blocking the flueways. If gasket is damaged, replace as needed.
2. Close and secure burner swing door to front section with fasteners.
3. Reconnect oil line(s).
4. Reinstall Top Panels and secure with sheet metal screws.
5. Reinstall smokepipe on canopy and secure to collar with sheet metal screws.

WARNING

The boiler must be connected to an approved chimney in good condition. Serious property damage could result if the boiler is connected to a dirty or inadequate chimney. The interior of the chimney flue must be inspected and cleaned before the start of the heating season and should be inspected periodically throughout the heating season for any obstructions. A clean and unobstructed chimney flue is necessary to allow noxious fumes that could cause injury or loss of life to vent safely and will contribute toward maintaining the boiler's efficiency.

VIII: BOILER CLEANING (continued)

NOTES:

1. PRIOR TO CLEANING BOILER, LAY A PROTECTIVE CLOTH OR PLASTIC OVER THE BLANKET TO COLLECT DEBRIS FALLING FROM FLUEWAYS.
2. AFTER CLEANING, INSPECT TARGET WALL, COMBUSTION CHAMBER BLANKET AND BURNER SWING DOOR INSULATION FOR SIGNS OF DAMAGE. IF DAMAGED, REPLACE AS NEEDED.
3. REPLACE CANOPY GASKET STRIPS AS NEEDED IF DAMAGED.

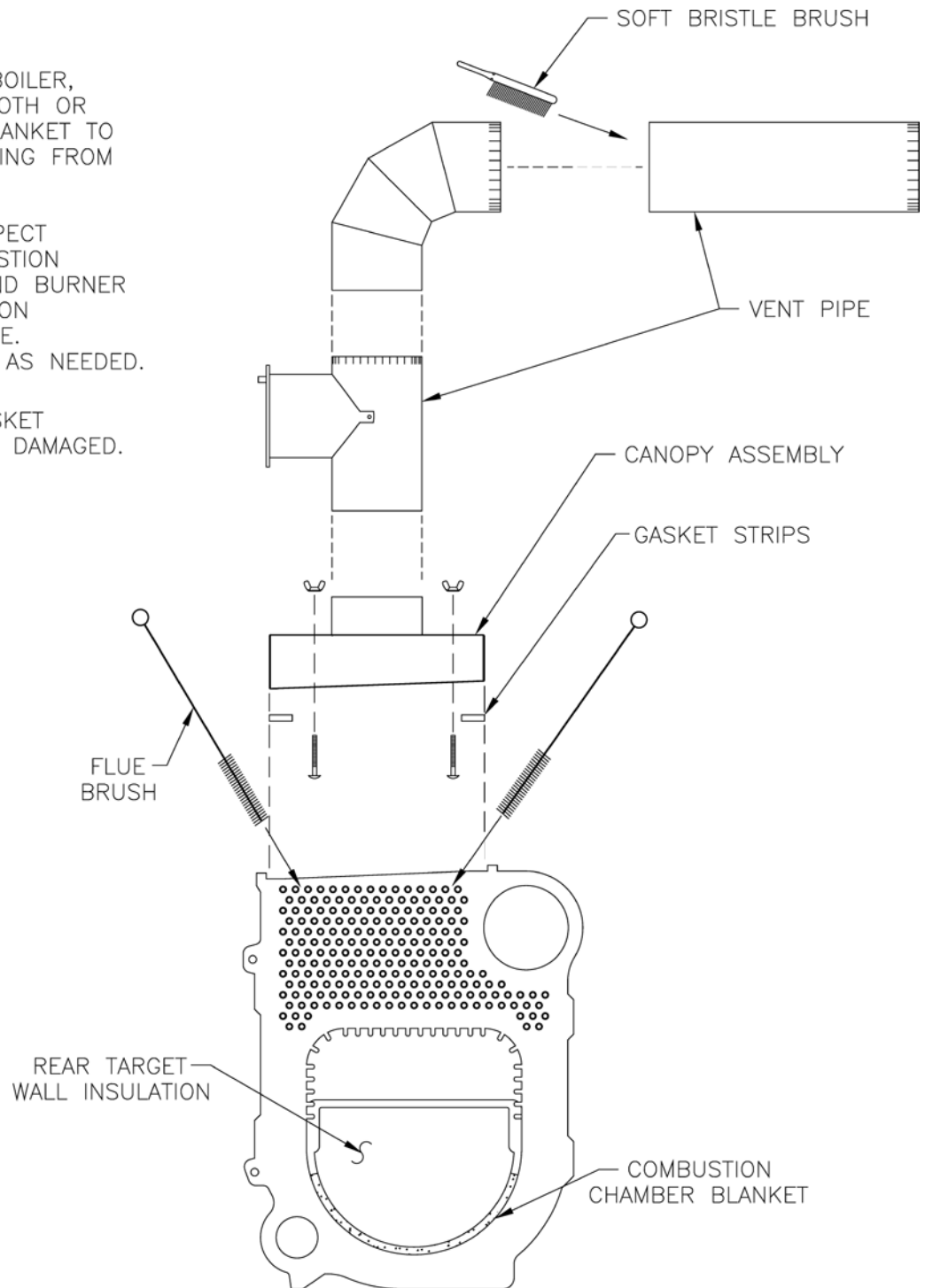

Figure 32: Cleaning of Boiler Flueways

Important Product Safety Information **Refractory Ceramic Fiber Product**

Warning:

The Repair Parts list designates parts that contain refractory ceramic fibers (RCF). RCF has been classified as a possible human carcinogen. When exposed to temperatures above 1805°F, such as during direct flame contact, RCF changes into crystalline silica, a known carcinogen. When disturbed as a result of servicing or repair, these substances become airborne and, if inhaled, may be hazardous to your health.

AVOID Breathing Fiber Particulates and Dust

Precautionary Measures:

Do not remove or replace RCF parts or attempt any service or repair work involving RCF without wearing the following protective gear:

1. A National Institute for Occupational Safety and Health (NIOSH) approved respirator
 2. Long sleeved, loose fitting clothing
 3. Gloves
 4. Eye Protection
- Take steps to assure adequate ventilation.
 - Wash all exposed body areas gently with soap and water after contact.
 - Wash work clothes separately from other laundry and rinse washing machine after use to avoid contaminating other clothes.
 - Discard used RCF components by sealing in an airtight plastic bag. RCF and crystalline silica are not classified as hazardous wastes in the United States and Canada.

First Aid Procedures:

- If contact with eyes: Flush with water for at least 15 minutes. Seek immediate medical attention if irritation persists.
- If contact with skin: Wash affected area gently with soap and water. Seek immediate medical attention if irritation persists.
- If breathing difficulty develops: Leave the area and move to a location with clean fresh air. Seek immediate medical attention if breathing difficulties persist.
- Ingestion: Do not induce vomiting. Drink plenty of water. Seek immediate medical attention.

IX: TROUBLESHOOTING

A. COMBUSTION

1. **Nozzles** — Although the nozzle is a relatively inexpensive device, its function is critical to the successful operation of the oil burner. The selection of the nozzle supplied with the CL boiler is the result of extensive testing to obtain the best flame shape and efficient combustion. Other brands of the same spray angle and spray pattern may be used but may not perform at the expected level of CO₂ and smoke. Nozzles are delicate and should be protected from dirt and abuse. Nozzles are mass-produced and can vary from sample to sample. For all of those reasons a spare nozzle is a desirable item for a serviceman to have.
2. **Fuel Leaks** — Any fuel leak between the pump and the nozzle will be detrimental to good combustion results. Look for wet surfaces in the air tube, under the ignitor, and around the air inlet. Any such leaks should be repaired as they may cause erratic burning of the fuel and in the extreme case may become a fire hazard.
3. **Suction Linw Leaks** — Any such leaks should be repaired, as they may cause erratic burning of the fuel and in extreme cases may become a fire hazard. Whatever it takes, **The Oil Must Be Free of Air**. This can be a tough problem, but it must be resolved. Try bleeding the pump through a clear tube. There must be no froth visible. There are various test kits available to enable you to look at the oil through clear tubing adapted to the supply line at the pump fitting. Air eliminators are on the market that have potential. Also, electronic sight glasses are being used with good success. At times, new tubing must be run to the tank or new fittings put on. Just make sure you get the air out before you leave.

Any air leaks in the fuel line will cause an unstable flame and may cause delayed ignition noises. Use only flare fittings in the fuel lines.

4. **Gasket Leaks** — If 11.5 to 12.5% CO₂ with a #1 smoke cannot be obtained in the breeching, look for air leaks around the burner mounting gasket, observation door, and canopy gasket. Such air leaks will cause a lower CO₂ reading in the breeching. The smaller the firing rate the greater effect an air leak can have on CO₂ readings.
5. **Dirt** — A fuel filter is a good investment. Accidental accumulation of dirt in the fuel system can clog the nozzle or nozzle strainer and produce a poor spray pattern from the nozzle. The smaller the firing rate, the smaller the slots become in the nozzle and the more prone to plugging it becomes with the same amount of dirt.
6. **Water** — Water in the fuel in large amounts will stall the fuel pump. Water in the fuel in smaller amounts will cause excessive wear on the pump, but more importantly water doesn't burn. It chills the flame and causes smoke and unburned fuel to pass out of the combustion chamber and clog the flueways of the boiler.
7. **Cold Oil** — If the oil temperature approaching the fuel pump is 40°F or lower, poor combustion or delayed ignition may result. Cold oil is harder to atomize at the nozzle. Thus, the spray droplets get larger and the flame shape gets longer. An outside fuel tank that is above grade or has fuel lines in a shallow bury is a good candidate for cold oil. The best solution is to locate the tank near the boiler in the basement utility room or bury the tank and lines deep enough to keep the oil above 40°F. Check environmental issues with local authorities having jurisdiction.
8. **Fame Shape** — Looking into the combustion chamber through the observation port, the flame should appear straight with no sparklers rolling up toward the crown of the chamber. If the flame drags to the right or left, sends sparklers upward or makes wet spots on the target wall, the nozzle should be replaced. If the condition persists look for fuel leaks, air leaks, water or dirt in the fuel as described above.
9. **High Altitude Installations** — Air openings must be increased at higher altitudes. Use instruments and set for 11.5 to 12.5% CO₂.
10. **Start-up Noise** — Late ignition is the cause of start-up noises. If it occurs recheck for electrode settings, flame shape, air or water in the fuel lines.
11. **Shut Down Noise** — If the flame runs out of air before it runs out of fuel, an after burn with noise may occur. That may be the result of a faulty cut-off valve in the fuel pump, or it may be air trapped in the nozzle line. It may take several firing cycles for that air to be fully vented through the nozzle. Water in the fuel or poor flame shape can also cause shut down noises.

NOTICE

CHECK TEST PROCEDURE. A very good test for isolating fuel side problems is to disconnect the fuel system and with a 24" length of tubing, fire out of an auxiliary five gallon pail of clean, fresh, warm #2 oil from another source. If the burner runs successfully when drawing out of the auxiliary pail then the problem is isolated to the fuel or fuel lines being used on the jobsite.

IX: TROUBLESHOOTING (continued)

B. OIL PRIMARY CONTROL (OIL PRIMARY)

1. **Burner (Oil Primary) will not come on.**
 - a. No power to Oil Primary.
 - b. Oil Primary is in lockout or restricted mode. Press reset button for one (1) second to exit lockout. If control has recycled three times within the same call for heat, it will enter into restricted mode. To reset from restricted mode, refer to Section V, Paragraph I, Step 2 for details.
 - c. CAD cell seeing light.
 - d. CAD assembly defective.
 - e. Control motor relay is stuck closed (see note below).
2. **Burner (control) will light**, then shut down after a short time, then restart after one (1) minute.
 - a. CAD cell is defective.
 - b. Air leaking into oil line causing flame out.
 - c. Defective nozzle causing flame to be erratic.
 - d. Excessive airflow or draft causing flame to leave burner head.
 - e. Excessive back pressure causing flame to be erratic.
3. Control locks out after Trial For Ignition (TFI).
 - a. No oil to burner.
 - b. Shorted electrodes.
 - c. Nozzle clogged.
 - d. Airflow too high.
 - e. Ignitor module defective.
 - f. CAD cell defective.
 - g. Oil valve stuck open or closed.

Note: The Safety Monitoring Circuit (SMC) is designed to provide lockout in the event of a stuck or welded motor relay.

Also refer to Model EZ-1/2/3 Oil Burner - Instruction Manual (Form #MNEZ123) for additional information.

4. Carlin 70200 Oil Primary Control

- a. Burner (control) will not come on.
 - i. No power to control.
 - ii. Control is in lockout. Press reset button for one (1) second.
 - iii. CAD cell seeing light.
 - iv. CAD assembly defective.
 - v. Control motor relay is stuck closed (see note below).
- b. Burner (control) will light, then shut down after a short time, then restart after one (1) minute.

- i. CAD cell is defective.
 - ii. Air leaking into oil line causing flame out.
 - iii. Defective nozzle causing flame to be erratic.
 - iv. Excessive airflow or draft causing flame to be erratic.
 - v. Excessive back pressure causing flame to be erratic.
- c. Control locks out after Trial For Ignition (TFI).
 - i. No oil to burner.
 - ii. Shorted electrodes.
 - iii. Nozzle clogged.
 - iv. Airflow too high.
 - v. Ignitor module defective.
 - vi. CAD cell defective.
 - vii. Oil valve stuck open or closed.

Note: The Safety Monitoring Circuit (SMC) is designed to provide lockout in the event of a stuck or welded motor relay.

NOTICE

If flame is not established within 15 seconds of oil valve actuation (known as Trial For Ignition [TFI]) lockout will occur. Lockout is indicated by a red LED solid-on located on the oil primary control.

Hard Lockout will occur if the Oil Primary Control locks-out three (3) times during a call for heat. This is indicated by red light reset button solid-on.

C. INTELLIGENT OIL BOILER CONTROL

- **Cold Start Boiler Control** is used on Boilers without Tankless Heaters.
 - **Warm Start Boiler Control** is used on Boilers with Tankless Heaters
1. **When a problem occurs** with the boiler operation, the Boiler Control easily provides specific, valuable information to help resolve the issue quickly. The display on the Boiler Control should be the first place to check.
 - a. If an Error Code "Err" **IS NOT** displayed on the Boiler Control: In this circumstance, Table 12 can be used to determine the problem and possible causes.

IX: TROUBLESHOOTING (continued)

TABLE 12: TROUBLESHOOTING GUIDE

System Condition	Diagnostic Condition	Check	Action
Boiler is cold, house is cold.	Display is OFF.	120 Vac System power.	Turn system power on.
	Display is ON.	24 Vac T-T	No 24 V; replace control.
		24 V present; disconnect thermostat, short T-T.	Boiler starts, check wiring and thermostat.
		120 Vac at B1-B2	<ul style="list-style-type: none"> If no, replace control. If yes, check burner and wiring.
	Refer to Err on display.	-----	
Boiler is hot, house is cold.	Display is ON.	120 Vac at C1-C2	<ul style="list-style-type: none"> 120 Vac at C1-C2, check wiring to pump. Wiring OK, is pump running? If not, replace the pump. If pump is running, check for trapped air or closed zone valves
		Boiler below the Low Limit temperature, wait for boiler to go above Low Limit temperature.	-----
		Boiler above LL? If yes, check for 120 Vac between ZC and L2.	<ul style="list-style-type: none"> If no 120 Vac, replace control. If yes, check zone relays, circulators and wiring.

- b. If the Boiler Control detects an error it will flash "Err" (boiler control error) followed by a number. Use this text and number to identify the boiler problem and corrective action in Table 13 below.

TABLE 13: BOILER CONTROL ERROR NUMBERS

Display	Status	Recommended Corrective Actions
Err 1	Temperature Sensor Fault	Temperature sensor failure, wire harness loose or shorted connection or control hardware failure: <ul style="list-style-type: none"> - Check sensor is securely attached to boiler control - Check that sensor wire is not damaged - If secure and in good condition, replace sensor - If problem persists, replace control
Err 2	Communication Fault	<u>ENVIRACOM TERMINAL IS SHORTED TO GROUND OR LINE VOLTAGE.</u> <u>- CHECK WIRING TO ENVIRACOM TERMINALS 1,2 AND 3. WIRING TO EXTERNAL ENVIRACOM DEVICE IS INCORRECT.</u>
Err 3	Internal Hardware Fault	Error detected with AC power supply frequency or boiler control failure. Cycle power to the control. Replace control if problem persists.
Err 4	Burner Output (B1) Fault	B1 output sensed powered during safety output relay check sequence or un-powered during running, or powered in idle in combination with water temperature above 264°F limit. Cycle power to the control. Replace control if problem persists.
Err 5	Line Voltage Fault (< 80 Vac)	AC voltage out of specification high or low; check L1, L2, 110 VAC.
Err 6	Fuse missing	Internal fuse is blown or missing. The fuse protects the Aquastat from miswiring the L1 and L2 on Oil Primary. When the Oil Primary is correctly wired the fuse is useless and not detected. If Primary is wired incorrectly the fuse is blown out and Aquastat report error 6. EnviraCOM message is sent when the wiring is fixed and the error disappears to indicate the end of the error state. Check wiring and replace fuse.
Err 7	User settings lost, (reset to factory defaults)	Warning: Generated if user adjustments are lost and the device uses factory default values. Error is cleared by entering and exiting the Adjustment mode. Replace control if problem persists.
Err 8	Manual Reset Lockout (resettable)	Set if Err 4 was invoked four times in a row. Check wiring and clear Lockout by pressing all three user keys for 30 seconds.

X: REPAIR PARTS

All **CL™ Series** repair parts may be ordered through New Yorker Boiler Company, Inc., or its authorized distributors.

Should you require assistance in locating a New Yorker Distributor in your area, or have questions regarding the availability of New Yorker products or repair parts, please contact: New Yorker Boiler Company, Inc., P.O. Box 10, Hatfield, PA 19440-0010, Attn: Customer Service Department. Visit our website at www.newyorkerboiler.com

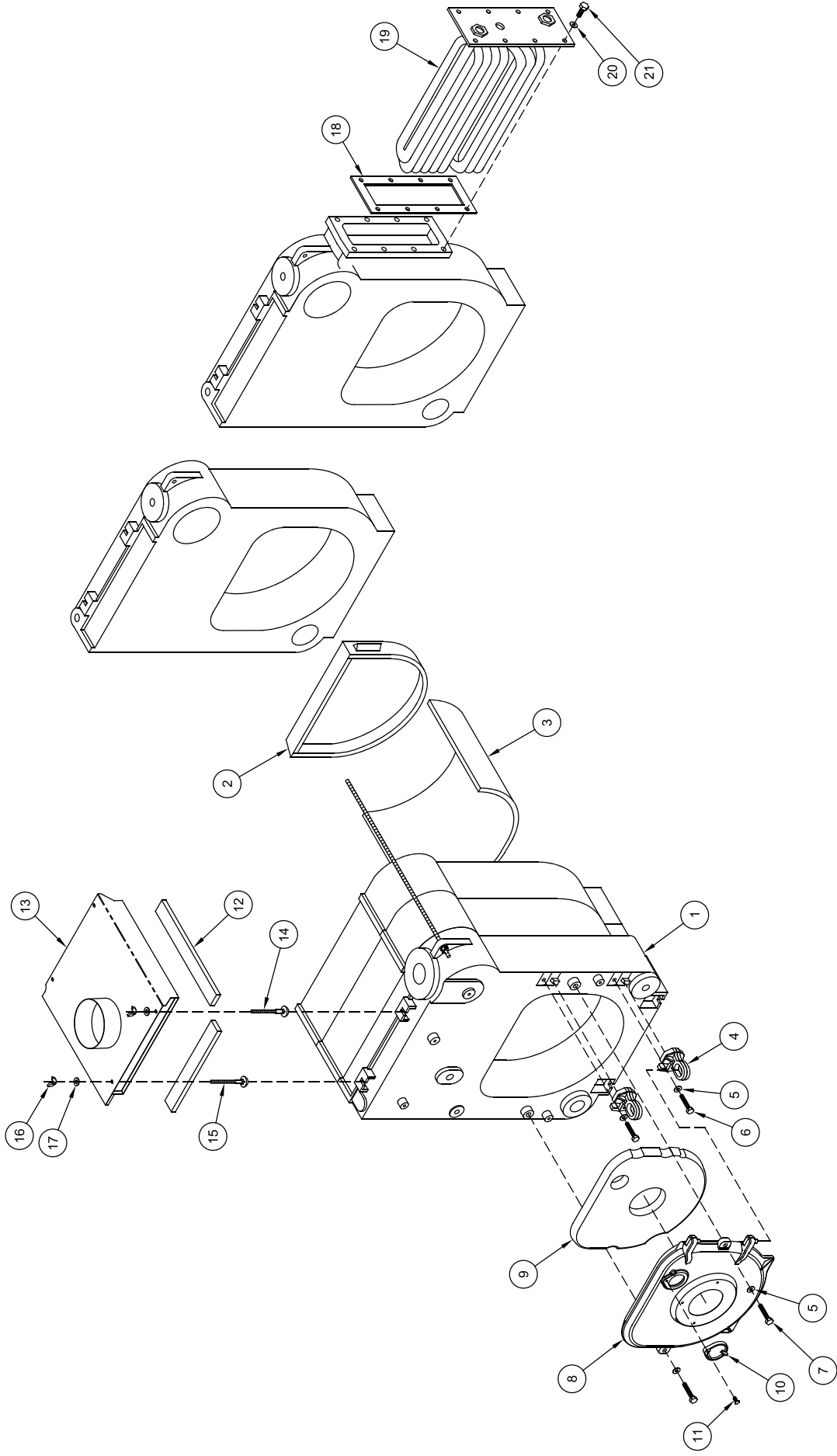

Bare Boiler Assembly (Exploded View)

X: REPAIR PARTS (continued)

Item No.	Description	Boiler Size / Quantity			Part No.
		CL3	CL4	CL5	
Bare Boiler Assembly					
1	Water Replacement Block Assembly, less coil	1	---	---	CL3-WN
	Water Replacement Block Assembly, less coil	---	1	---	CL4-WN
	Water Replacement Block Assembly, less coil	---	---	1	CL5-WN
	Water Replacement Block Assembly, with coil	1	---	---	CL3-WR
	Water Replacement Block Assembly, with coil	---	1	---	CL4-WR
	Water Replacement Block Assembly, with coil	---	---	1	CL5-WR
	Steam Replacement Block Assembly, less coil	1	---	---	61720307
	Steam Replacement Block Assembly, less coil	---	1	---	61720407
	Steam Replacement Block Assembly, less coil	---	---	1	61720507
	Steam Replacement Block Assembly, with coil	1	---	---	61720306
	Steam Replacement Block Assembly, with coil	---	1	---	61720406
	Steam Replacement Block Assembly, with coil	---	---	1	61720506
2	Rear Target Wall Insulation	1	1	1	82020002
3	Combustion Chamber Liner, 1/2" x 19-1/2" x 9-3/4"	1	---	---	82020031
	Combustion Chamber Liner, 1/2" x 19-1/2" x 14-3/4"	---	1	---	82020041
	Combustion Chamber Liner, 1/2" x 19-1/2" x 19-3/4"	---	---	1	82020051
4	BSD Hinge Loop Bracket	2	2	2	100795-02
5	5/16" Flat Washer - Plated	4	4	4	80860611
6	5/16-18 x 1" Lg. Cap Screw, Plated	2	2	2	80861341
7	5/16-18 x 1-1/2" Lg. Cap Screw, Plated	2	2	2	80861349
8	Burner Swing Door (only), Machined / Painted	1	1	1	100793-01
9	Burner Swing Door Insulation	1	1	1	82020001
10	Observation Port Cover, Machined / Painted	1	1	1	71728004
11	5/16-18 x 3/4" Lg. Cap Screw, Plated	1	1	1	80861340
12	Canopy Sealing Strip (1/2" x 1-1/4" x 10') in Poly Bag	1	1	1	6206001
13	Canopy Assembly - 3 Section, 5-7/8" Dia. Collar	1	---	---	104585-03
	Canopy Assembly - 4 Section, 6-7/8" Dia. Collar	---	1	---	104585-04
	Canopy Assembly - 5 Section, 7-7/8" Dia. Collar	---	---	1	104585-05
14	1/4"-20 x 3" Lg. Carriage Bolt, Plated	2	2	2	80860119
15	1/4"-20 x 3-1/2" Lg. Carriage Bolt, Plated	2	2	2	100838-01
16	1/4"-20 Wing Nut - Plated	4	4	4	80860910
17	1/4" Flat Washer - Plated	4	4	4	80860603
18	Heater Cover Plate Gasket - Rear Heater	1	1	1	8036058
19	V1-2 Heater Carton (WT[R] & ST[R]) Rear Heater	1	1	1	6036031
20	5/16" Flat Washer - Plated	8	8	8	80860611
28	3/8"-16 x 7/8" Lg. Cap Screw, ASME Grade, Marked SA307B	8	8	8	80861337

X: REPAIR PARTS (continued)

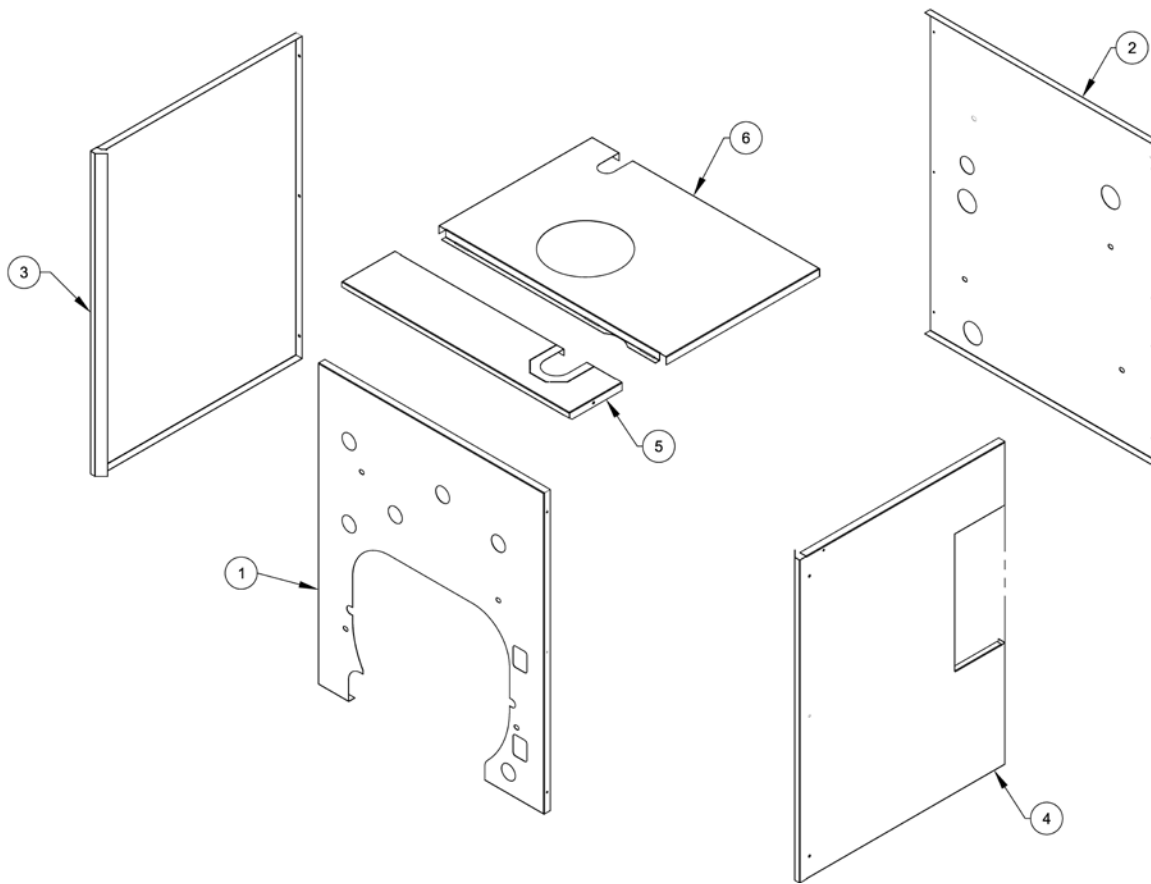

Jacket Assembly (Exploded View)

Item No.	Description	Boiler Size / Quantity			Part No.	
		CL3	CL4	CL5		
Jacket Components -- Items 1 thru 6 Include Insulation as Part of Assembly						
1	Jacket Front Panel Assembly	1	1	1	100819-01	
2	Jacket Rear Panel Assembly	1	1	1	100820-01	
3	Jacket Reversible Side Panel Assembly	Non-Heater Build	2	---	---	100821-03
			---	2	---	100821-04
			---	---	2	100821-05
		With Heater Build	1	---	---	100821-03
			---	1	---	100821-04
			---	---	1	100821-05
4	Jacket Left Side Heater Panel Assembly (WT[R] & ST[R] Heater Builds)	1	---	---	100824-03	
		---	1	---	100824-04	
		---	---	1	100824-05	
5	Jacket Split Front Top Panel Assembly	1	1	1	100823-01	
6	Jacket Split Rear Top Panel Assembly	1	---	---	100822-03	
		---	1	---	100822-04	
		---	---	1	100822-05	

X: REPAIR PARTS (continued)

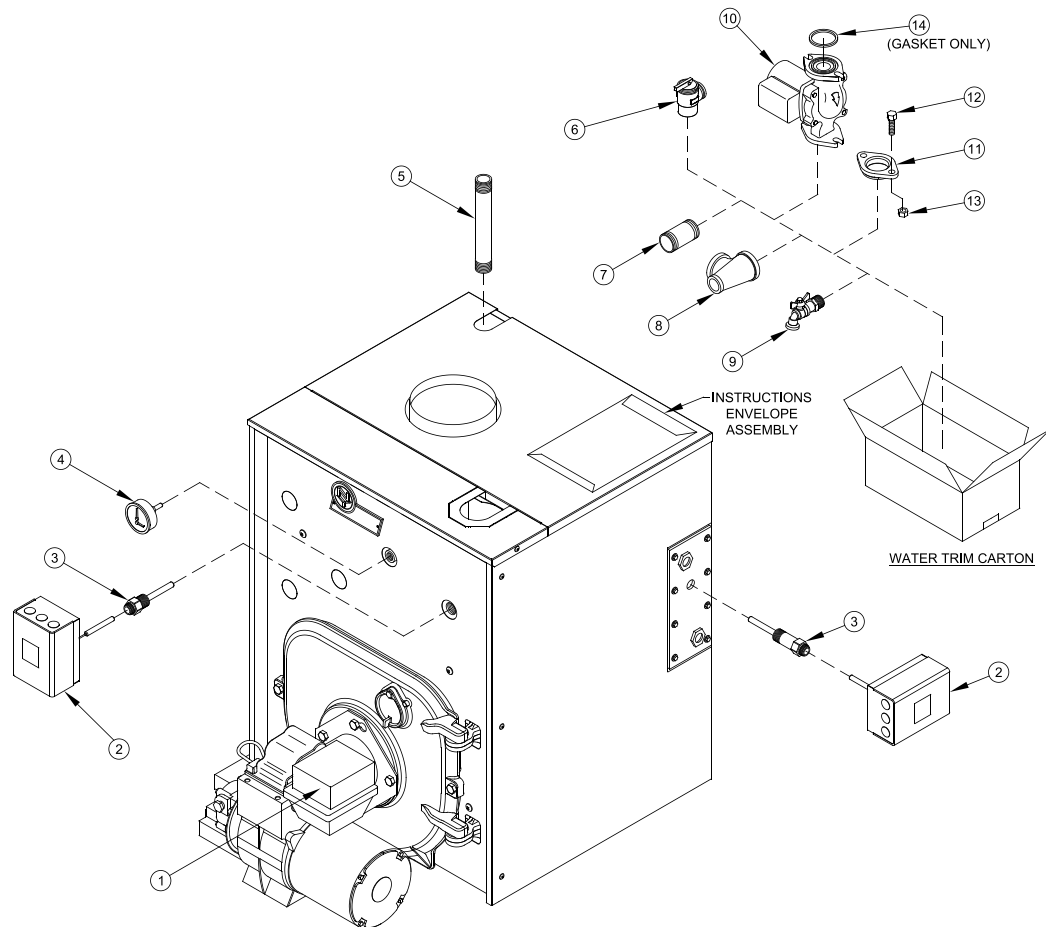

CL3 Thru CL5 Water Boilers - Trim and Controls

Item No.	Description	Boiler Size / Quantity			Part No.	
		CL3	CL4	CL5		
CL3 Thru CL5 Water Boilers - Trim and Controls						
1	Beckett GeniSys 7505B Oil Primary Control	1	1	1	103447-01	
2a	Honeywell L7248L1090 Hi Limit, Circ. Relay (WL)	1	1	1	103850-01	
	Honeywell L7224C1010 Hi & Lo Limit, Circ. Relay (WT)				103854-01	
2b	Hydrolevel HydroStat 48-3257 Boiler control (WL)	1	1	1	104579-01	
	Hydrolevel HydroStat 48-3257TCE Boiler Control (WT)				106967-01	
3a	1/2" NPT x 1-1/2" Immersion Well, Honeywell 123869A (WL)	1	1	1	80160456	
	3/4" NPT x 3" Immersion Well, Honeywell 123871A (WT)				80160452	
3b	1/2" NPT x 1" Electro-Well, Hydrolevel 48-221 (WL)	1	1	1	104098-01	
	3/4" NPT x 4" Electro-Well, Hydrolevel 48-206 (WT)				105310-01	
4	Temperature / Pressure Gauge, 1/4" NPT x 2-1/2" Dia. x 1-1/2" Lg. Shank	1	1	1	100282-01	
5	3/4" NPT x 7-1/4" Lg. Nipple, SCH 80, Black	1	1	1	100839-01	
6	Relief Valve, 3/4" F x 3/4" F, 30 PSI, #10-408-05	1	1	1	81660319	
7	1-1/2" NPT x 5" Lg. Nipple, Black	1	1	1	806600060	
8	1-1/2" x 3/4" x 1-1/2" NPT Tee, Black	1	1	1	806601003	
9	3/4" NPT Ball Drain Valve, Conbraco #35-302-03	1	1	1	806603061	
10	Circulator w/Gaskets	Taco 007	1	1	1	8056170
		Grundfos UP15-42F	1	1	1	8056173
11	Circulator Flange, 1-1/2" NPT	2	2	2	806602014	
12	Cap Screw, Hex Head, 7/16" -14 x 1-1/2" Lg.	4	4	4	80861301	
13	Hex Nut, 7/16" -14	4	4	4	80860406	
14	Taco "00" Series Flange Gasket (Gasket Only)	2	2	2	806602006	

X: REPAIR PARTS (continued)

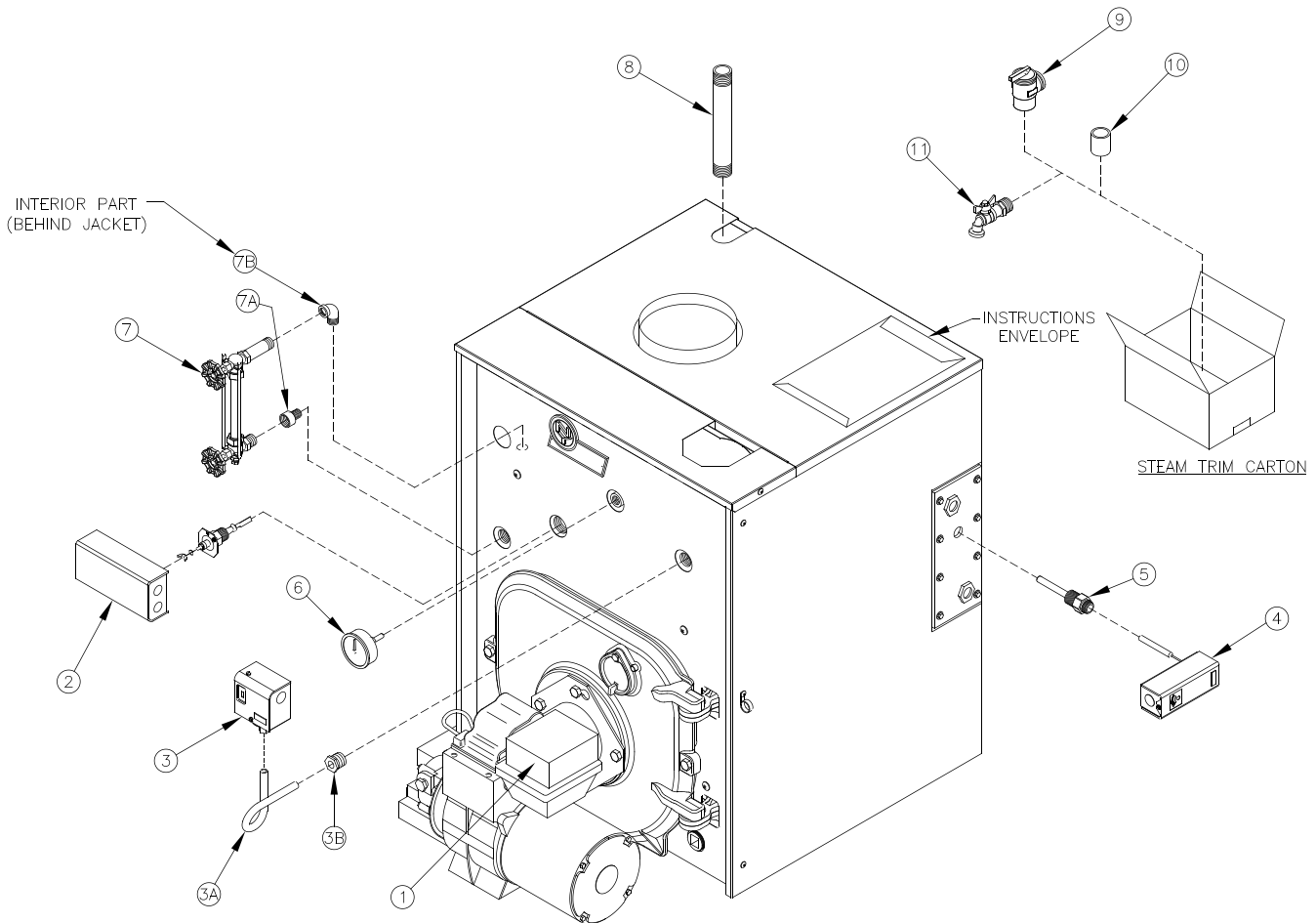

CL3 Thru CL5 Steam Boilers - Trim and Controls

Item No.	Description	Boiler Size / Quantity			Part No.
		CL3	CL4	CL5	
CL3 Thru CL5 Steam Boilers - Trim and Controls					
1	Beckett GeniSys 7505B Oil Primary Control	1	1	1	103447-01
2	McDonnell & Miller PSE801-120 LWCO With Probe	1	1	1	80160723
3	Honeywell PA404A1009 Pressuretrol	1	1	1	80160300
3A	1/4" x 90° Syphon, 1-7/8" Equal Leg	1	1	1	806603014
3B	1/2" x 1/4" NPT Bushing, Black / Steel	1	1	1	806600524
4	Honeywell L4006A2015 Aquastat	1	1	1	80160400
5	3/4" NPT x 3" Immersion Well, Honeywell #123871A	1	1	1	80160452
6	Steam Gauge, 1/4" NPT x 2-1/2" Dia. x 7/8" Shank	1	1	1	100325-01
7	10 1/4" Gauge Glass Set, Conbraco #22-171-10	1	1	1	100854-01
7A	1/2" Male x 1/2" Female NPT Brass Extension Piece	1	1	1	100853-01
7B	1/2" NPT Brass Street Elbow	1	1	1	100852-01
8	3/4" NPT x 7 1/4" Lg. Nipple, SCH 80, Black	1	1	1	100839-01
9	3/4" NPT, M/F, 15 PSI Safety Valve Conbraco #13-511-B15	1	1	1	81660530
10	3/4" NPT Coupling, Malleable	1	1	1	806602561
11	3/4" NPT Ball Drain Valve, Conbraco #35-302-03	1	1	1	806603061

X: REPAIR PARTS (continued)

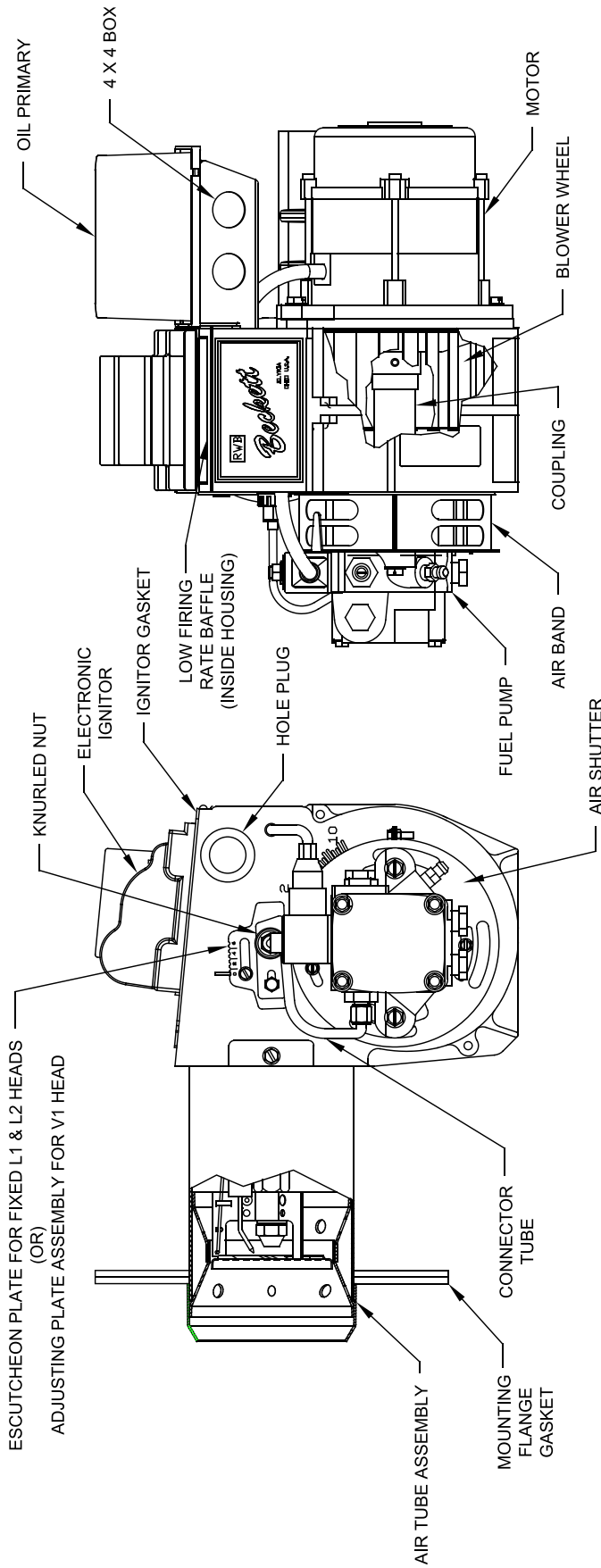

SIDE VIEW

FRONT VIEW

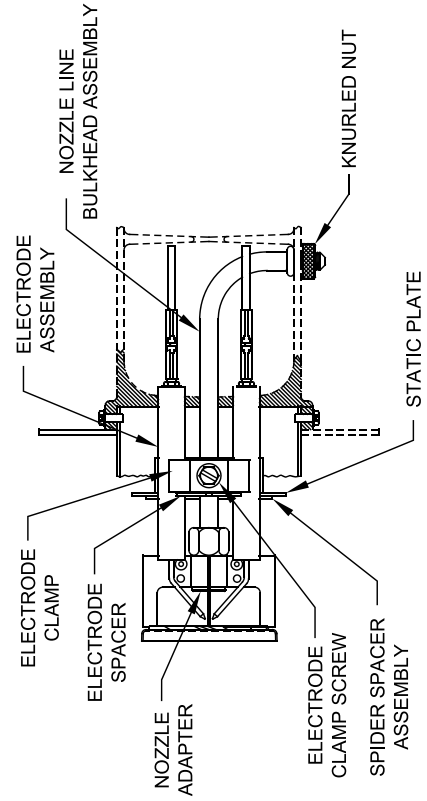

NOZZLE DETAIL

Beckett AFG Burner

BECKETT AFG OIL BURNER PART NOS. FOR CL SERIES BOILERS

NOTE: When ordering parts always give the serial and model numbers shown on the boiler and burner. Also provide the name of the part(s) and part number as listed below.

Boiler Model	CL3-091, 105, 140	CL4-126	CL4-175, 210	CL5-168, 245, 280
Air Tube Combination	AFG70MMAQ	AFG70MMAQ	AFG70MDAQ	AFG70MLAQ
Beckett's Spec No.	NY2710	NY2711	NY2712	NY2713
Air Band	3492A	3492A	3492A	3492A
Air Band Nut	4150	4150	4150	4150
Air Band Screw	4198	4198	4198	4198
Air Shutter	3709	3709	3709	3709
Air Shutter Screw	4198	4198	4198	4198
Blower Wheel	2999	2999	2999	2999
Coupling	2454	2454	2454	2454
Low Firing Rate Baffle	5880[1]	----	----	----
Bulkhead Knurled Locknut	3-666	3-666	3-666	3-666
Connector Tube Assembly	5636	5636	5636	5636
Electrode Clamp	1-49	1-49	1-49	1-49
Electrode Clamp Screw	4219	4219	4219	4219
Electrode Insulator Assembly	5780	5780	5780	5780
Spider Spacer Assembly	5653	5653	5653	5653
Escutcheon Plate	3493	3493	----	----
Adjusting Plate Assembly	----	----	5941	5941
Head	5912	5912	5913	5913
Head Screws	4221	4221	4221	4221
Flange Gasket	3416	3416	3416	3416
AFG Housing	5874BK	5874BK	5874BK	5874BK
Motor	21805	21805	21805	21805
Nozzle Adapter	2-13	2-13	2-13	2-13
Nozzle Line Electrode Assembly	NL70MM	NL70MM	NL70MD	NL70ML
Oil Pump, Clean Cut (Single Stage)	2184404U	2184404U	2184404U	2184404U
Oil Pump, Clean Cut (Two Stage)	21941U	21941U	21941U	21941U
Static Plate	3384	3384	3383	Less
Ignitor	51771U	51771U	51771U	51771U
Ignitor Hinge Screw	4217	4217	4217	4217
Ignitor Holding Screw	4292	4292	4292	4292
Ignitor Gasket Kit	51304	51304	51304	51304
Junction Box	5770	5770	5770	5770
Flame Detector	7006	7006	7006	7006
Oil Solenoid Valve Coil	21755	21755	21755	21755
Oil Solenoid Valve Cord	21807	21807	21807	21807

[1] 5880 used on CL3-091 firing rate only

XI: BURNER SPECIFICATIONS

TABLE 14A: BECKETT AFG BURNER SPECIFICATIONS

Beckett AFG							
Boiler Series	Firing Rate GPH	Settings			Nozzle		³ Pump Pressure
		Head (Setting)	Air Shutter	Air Band	GPH x Angle Type	² Shipped	
¹ CL3-091	0.65	L1	8	0	0.55 x 70B (Delavan)	▲ Loose	140
CL3-105	0.75		10	2	0.65 x 60B (Hago)	▲ Loose	
▲ CL3-140	1.00		5	2	0.85 x 60B (Hago)	Installed	
CL4-126	0.90	L1	7	0	0.75 x 60B (Delavan)	Installed	140
CL4-175	1.25	V1(0)	10	0.5	1.00 x 60B (Hago)	* Loose	140
* CL4-210	1.50		10	6	1.25 x 60B (Hago)	Installed	
CL5-168	1.20	V1(0)	8	1	0.90 x 60B (Hago)	* Loose	175
CL5-245	1.75	V1(3)	6	6	1.35 x 45B (Hago)	* Loose	
* CL5-280	2.00	V1(4)	8	4	1.50 x 45B (Hago)	Installed	

¹ Beckett low firing rate baffle required on CL3-091 (0.65 GPH) application only; shipped loose with nozzle.

² Nozzle(s) for alternate boiler series firing rate(s) are shipped loose in bag attached to the burner designated by corresponding symbol, i.e. (▲) = CL3-140.

³ Single stage fuel pump is standard, two stage fuel pump is optional. Burner manufacturer has preset single stage fuel pump to settings shown in table above.

XI: BURNER SPECIFICATIONS (continued)

RIELLO 40 SERIES OIL BURNER PART NUMBERS FOR CL SERIES BOILERS

TABLE 14B: RIELLO BURNER SPECIFICATIONS

Boiler Series	Firing Rate GPM	Burner Model	Settings		Nozzle		Pump Pressure
			Air Gate	Turbulator	GPH x Angle Type	² Shipped	
CL3-105	0.75	40F5	2.60	0	0.60 x 60A (Delavan)	Installed	150
CL3-140	1.00		2.85	2	0.85 x 60W (Delavan)	Loose	
CL4-126	0.90	40F5	2.25	0	0.75 x 60B (Delavan)	Installed	150
CL4-175	1.25	40F5	4	4	1.00 x 60A (Delavan)	Installed	150
CL4-210	1.50	40F5	3	1	1.25 x 60B (Delavan)	Installed	150
CL5-168	1.20	40F5	2.9	0	1.00 x 80B (Delavan)	Installed	150
CL5-245	1.75	40F10	3	1.5	1.35 x 45B (Delavan)	* Loose	150
* CL5-280	2.00		3.8	2	1.65 x 45B (Delavan)	Installed	

² Nozzle(s) for alternate boiler series firing rate(s) are shipped loose in bag attached to the burner designated by corresponding symbol, i.e. (*) = CL5-280.

NOTE: When ordering parts always give the serial and model numbers shown on the boiler and burner.

Refer to Models F3 & F5 Installation Manual, Riello 40 Series Residential Oil Burners (C6501010) or Model F10 Installation Manual, Riello 40 Series Residential Oil Burners (2902554) for an exploded view of the burner and a list of spare parts.

For replacement Riello oil burner parts, contact your wholesaler or the burner manufacturer:

Riello Corporation of America
 35 Pond Park Road
 Hingham, Massachusetts 02043
 Telephone: (781) 749-8292
 Toll Free: (outside Massachusetts)
 (800) 474-3556

Riello Canada Inc.
 2165 Meadowpine Blvd.
 Mississauga, Ontario L5N 6H6
 Telephone: (905) 542-0303
 Facsimile: (905) 542-1525
 Toll Free: (800) 387-3898

XI: BURNER SPECIFICATIONS (continued)

CARLIN OIL BURNER PART NUMBERS FOR CL SERIES BOILERS

NOTE: When ordering parts always give the serial and model numbers shown on the boiler and burner.

Refer to Carlin Model EZ-1/2/3 Oil Burner-Instruction Manual (Form #MNEZ123) for an exploded view of the burner and a list of spare parts.

For replacement Carlin oil burner parts, contact your wholesaler or the burner manufacturer:

CCT, Carlin Combustion Technology, Inc.
126 Baily Road
North New Haven, CT 06475
Telephone: (203) 680-9401

TABLE 14C: CARLIN EZ-1HP AND EZ-2HP BURNER SPECIFICATIONS

Boiler Series	Firing Rate GPH	Burner Model	Settings		Nozzle		³ Pump Pressure
			Head Bar	Air Band	GPH x Angle Type	² Shipped	
CL3-091	0.65	EZ-1HP	0.50	0.55	0.55 x 70B (Delavan)	▲ Loose	150
CL3-105	0.75		0.60/0.65	0.60	0.60 x 60ES (Hago)	▲ Loose	
▲ CL3-140	1.00		0.85/1.00	0.75	0.85 x 60B (Hago)	Installed	
CL4-126	0.90	EZ-1HP	0.75	0.75	0.75 x 60A (Delavan)	* Loose	150
CL4-175	1.25		0.85/1.00	1.00-1.10	1.00 x 60A (Delavan)	* Loose	
* CL4-210	1.50		1.10/1.25	1.25-1.35	1.25 x 60B (Hago)	Installed	
CL5-168	1.20		0.85/1.00	0.90	1.00 x 60B (Hago)	Installed	150
CL5-245	1.75	EZ-2HP	1.50	1.75	1.50 x 60A (Delavan)	Installed	150

² Nozzle(s) and Head Positioning Bar Kit for alternate boiler series firing rate(s) are shipped loose in bag attached to the burner designated by corresponding symbol, i.e. (▲) = CL3-140.

³ Single stage fuel pump is standard, two stage fuel pump is optional. Burner manufacturer has preset single stage fuel pump to settings shown in table above.

APPENDIX A - AFTERMARKET LOW WATER CUT OFF (LWCO)

WARNING

DO NOT ATTEMPT to cut factory wires to install an aftermarket Low Water Cut Off (LWCO). Only use connections specifically identified for Low Water Cut Off.

In all cases, follow the Low Water Cut Off (LWCO) manufacturer's instructions.

When

A low water cutoff is required to protect a hot water boiler when any connected heat distributor (radiation) is installed below the top of the hot water boiler (i.e. baseboard on the same floor level as the boiler). In addition, some jurisdictions require the use of a LWCO with a hot water boiler.

Where

The universal location for a LWCO on oil hot water boilers is above the boiler, in either the supply or return piping. The minimum safe water level of a water boiler is at the uppermost top of the boiler; that is, it must be full of water to operate safely.

It is recommended that the LWCO control is installed above the boiler to provide the highest level of protection. However, where the LWCO control is approved by the LWCO control manufacturer for installation in a high boiler tapping of a water boiler, the use of the listed LWCO control is permitted when it is installed according to the LWCO manufacturer's instructions

What Kind

Typically, in residential applications, a probe type LWCO is used instead of a float type, due to their relative costs and the simplicity of piping for a probe LWCO.

How to Pipe

A "tee" is commonly used to connect the probe LWCO in the supply or return piping, as shown below.

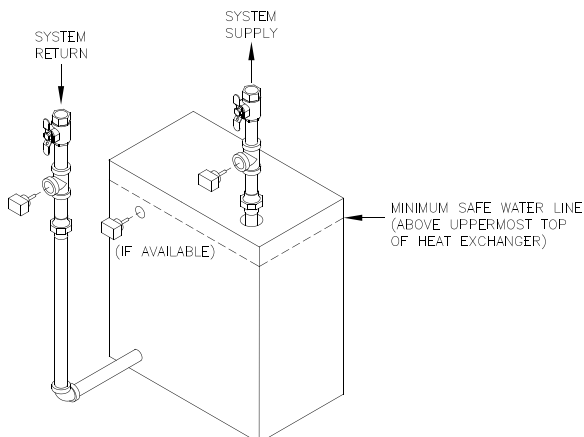

Figure A1: LWCO Location

Select the appropriate size tee using the LWCO manufacturer's instructions. Often, the branch connection must have a minimum diameter to prevent bridging between the probe and the tee. Also, the run of the tee must have a minimum diameter to prevent the end of the probe from touching or being located too close to the inside wall of the run of the tee.

Ideally, manual shutoff valves should be located above the LWCO and the boiler to allow for servicing. This will allow probe removal for inspection without draining the heating system. Many probe LWCO manufacturers recommend an annual inspection of the probe.

How to Wire

LWCO's are available in either 120 VAC or 24 VAC configurations. The 120 VAC configuration must be applied to oil boilers by wiring it in the line voltage service to the boiler (after the service switch, if so equipped). Refer to Figure A2.

The presence of water in a properly installed LWCO will cause the normally open contact of the LWCO to close, thus providing continuity of the 120 VAC service to the boiler.

It is recommended to supply power to the probe LWCO with the same line voltage servicing the boiler as shown below.

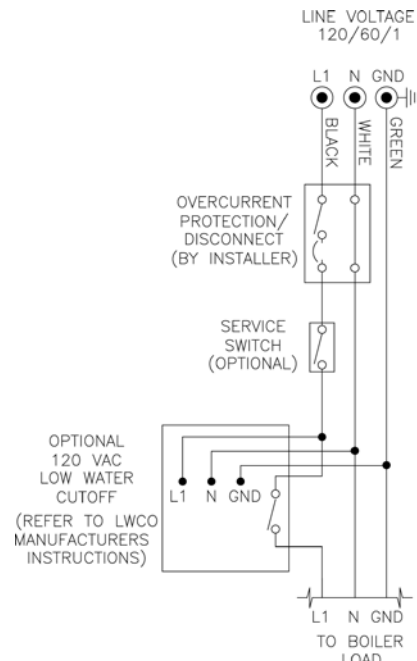

Figure A2: Wiring of Typical LWCO

APPENDIX A - AFTERMARKET LOW WATER CUT OFF (LWCO) (continued)

How to Test

Shut off fuel supply. Close shut-off valves in system supply and return piping located in near boiler piping above LWCO as shown in Figure A1. Open drain valve to lower water level until water is below the LWCO probe. It may be necessary to open relief valve seat to allow air into system for the water to drain, close drain

valve and relief valve once completed. Generate a boiler demand by turning up thermostat. Boiler should not attempt to operate. Open fill valve to increase the water level by filling the system. It may be necessary to open relief valve to allow air to escape during filling process. The boiler should attempt to operate once the water level is above the LWCO.

NEW YORKER BOILER COMPANY, INC.

Limited Warranties

For Residential Cast Iron and Steel Boilers

By this Warranty Statement New Yorker Boiler Company, Inc. ("New Yorker"), issues limited warranties subject to the terms and conditions stated below. These limited warranties apply to residential cast iron and steel water boilers labeled with the New Yorker® brand which are sold on or after March 1, 2004.

ONE YEAR LIMITED WARRANTY

One Year Limited Warranty for Residential Water Boilers New Yorker warrants to the original consumer purchaser at the original installation address that its residential cast iron and steel water boilers will be free from defects in material and workmanship under normal usage for a period of one year from the date of original installation. In the event that any defect in material or workmanship is found during the one year period following the date of installation, New Yorker will, at its option, repair the defective part or provide a replacement free of charge, F.O.B. its factory.

LIFETIME LIMITED WARRANTY

For all gas/oil-fired residential boilers, New Yorker warrants to the original consumer purchaser at the original installation address that the heat exchanger of the boiler will be free of defects in material and workmanship under normal usage for the lifetime of the original consumer purchaser. In the event that any defect in material or workmanship is found during the ten year period following the date of installation, New Yorker will, at its option, repair the defective pressure vessel or provide a replacement free of charge, F.O.B. its factory. In the event that any defect in material or workmanship is found after the tenth year following the date of installation, New Yorker will provide a replacement pressure vessel upon payment by the original consumer purchaser of an amount equal to a percentage of the then current retail price of the model boiler involved (or, in the event that such model is not then in production, the most comparable model then in production), as follows:

	Service Charge as a % of Retail Price																								
Years in Service	1-5	6	7	8	9	10	11	12	13	14	15	16	17	18	19	20	21	22	23	24	25+				
Stainless Steel	No Charge					30	40	50	60	70	100														
Water Boilers	No Charge					5	10	15	20	25	30	35	40	45	50	55	60	65	70	75					
Steam Boilers	No Charge					100																			

EXCEPTIONS AND EXCLUSIONS

- Components Manufactured by Others** - following the expiration of the foregoing one year limited warranty, all component parts of a boiler which are manufactured by others (such as burners, burner controls, circulator, tankless water heater, and New Yorker Link) shall be subject only to the manufacturer's warranty, if any.
- Removal and Replacement Costs** - these warranties do not cover expenses of removal or reinstallation. The consumer purchaser will be responsible for the cost of removing and replacing any defective part and all labor and related materials connected therewith. Replacement parts will be invoiced to the distributor in the usual manner and will be subject to adjustment upon proof of defect.
- Proper Installation** - these warranties are conditioned upon the installation of the boiler in strict compliance with New Yorker's Installation, Operating and Service Instructions. New Yorker specifically disclaims any liability of any kind which arises from or relates to improper installation.
- Improper Use or Maintenance** - these warranties will not be applicable if the boiler is used or operated over its rated capacity, is installed for uses other than home heating, or is not maintained in accordance with New Yorker's Installation, Operating and Service Instructions and hydronics industry standards.
- Improper Operation** - these warranties will not be applicable if the boiler has been damaged as a result of being improperly serviced or operated, including but not limited to the following: operated with insufficient water; allowed to freeze; subjected to flood conditions; or operated with water conditions and/or fuels or additives which cause unusual deposits or corrosion or on the pressure vessel or associated controls.

- Geographic Limitations** - these warranties apply only to boilers installed within the 48 contiguous United States.
- Installation Requirements** - in order for these warranties to be effective:
 - The boiler must be installed in a single or two-family residential dwelling. This warranty does not apply to boilers installed in apartments for commercial or industrial applications.
 - The boiler must be installed in strict compliance with New Yorker's Installation, Operating and Service Instructions by an installer regularly engaged in boiler installations.
 - Boiler sections must not have been damaged during shipment or installation.
 - The boiler must be vented in accordance with chimney recommendations set forth in New Yorker's Installation, Operating and Service Instructions.
- Exclusive Remedy** - New Yorker's obligation in the event of any breach of these warranties is expressly limited to the repair or replacement of any part found to be defective under conditions of normal use.
- Limitation of Damages Under no circumstances will New Yorker be liable for incidental, indirect, special or consequential damages of any kind under these warranties, including, without limitation, injury or damage to persons or property and damages for loss of use, inconvenience or loss of time.** New Yorker's liability under these warranties shall under no circumstances exceed the purchase price paid for the boiler involved. Some states do not allow the exclusion or limitation of incidental or consequential damages, so the above limitation or exclusion may not apply to you.
- Limitation of Warranty** - these limited warranties are given in lieu of all other express warranties and set forth the entire obligation of New Yorker with respect to any defect in a residential water boiler. New Yorker shall have no express obligations, responsibilities or liabilities of any kind, other than those set forth herein.

ALL APPLICABLE IMPLIED WARRANTIES, IF ANY, INCLUDING ANY WARRANTY OF MERCHANT ABILITY OR FITNESS FOR A PARTICULAR PURPOSE, ARE EXPRESSLY LIMITED DURATION TO A PERIOD OF ONE YEAR, EXCEPT THAT IMPLIED WARRANTIES, IF ANY, APPLICABLE TO THE PRESSURE VESSEL OF A RESIDENTIAL WATER BOILER SHALL BE LIMITED IN DURATION TO THE LESSER OF THE DURATION OF SUCH IMPLIED WARRANTY OR A PERIOD EQUAL TO THE TERM OF THE APPLICABLE EXPRESS WARRANTY.

Some states do not allow limitations on how long an implied warranty lasts, so the above limitation may not apply to you.

PROCEDURE FOR OBTAINING WARRANTY SERVICE

Upon discovery of a condition believed to be related to a defect in material or workmanship covered by these warranties, the original consumer purchaser should notify the installer, who will in turn notify the distributor. If this action is not possible or does not produce a prompt response, the original consumer purchaser should write to New Yorker Boiler Company, Inc. at P.O. Box 10, Hatfield, PA 19440-0010, giving full particulars in support of the claim.

The original consumer purchaser is required to make available for inspection by New Yorker or its representatives the parts claimed to be defective and, if requested by New Yorker, to ship those parts prepaid to New Yorker at the above address for inspection or repair. In addition, the original consumer purchaser agrees to make all reasonable efforts to settle any disagreement arising in connection with any warranty claim before resorting to legal remedies in the courts.

THIS WARRANTY GIVES YOU SPECIFIC LEGAL RIGHTS AND YOU MAY ALSO HAVE OTHER RIGHTS WHICH VARY FROM STATE TO STATE.



New Yorker[®]
RESIDENTIAL HEATING BOILERS