



SYMMONS® Ultra-Sense™

Lavatory Faucet S-6080

Battery Powered, Sensor-Activated Installation, Operation & Service Brief



Model Numbers

- S-6080.....Sensor Faucet
- S-6080-G...Sensor Faucet with grid strainer drain assembly

Tools & Materials

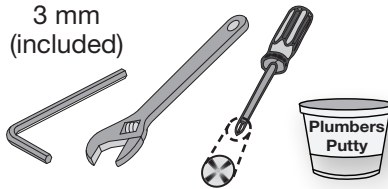

☎ Need Help?

Symmons customer service:
(800) 796-6667, (781) 848-2250
Email: customerservice@symmons.com
Monday - Friday 7:30 am - 7:00 pm EST

 www.symmons.com/service

- Technical help
- Product information
- Warranty policy

Quick Install Guide *Ultra-Sense Lavatory Faucet, S-6080*

Single hole mount

Step 1
Attach faucet to deck

Step 2
Connect water supply lines

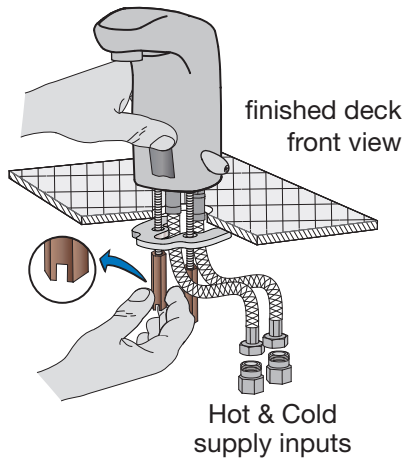

Operation (sensor activated)

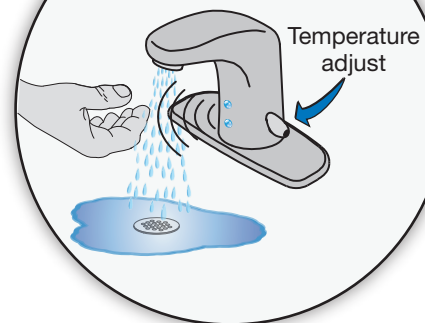

Three hole mount

Step 1
Attach faucet to deck with deck plate

Step 2
Connect water supply lines

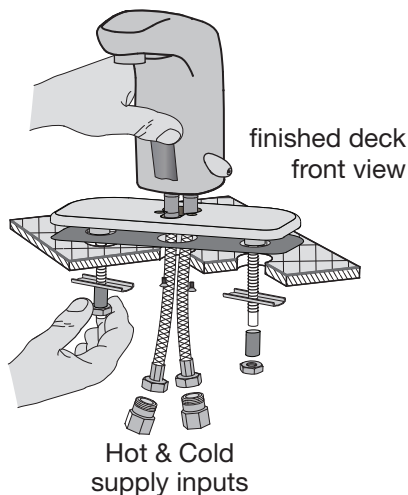

Water supply configuration options

1) Hot & Cold supply with temperature adjust lever handle (*factory standard*)



2) Hot & Cold supply with preset tempered water (*field configured*)



3) Single supply with mixed tempered water (*field configured*)



Installation Instructions

Important! Prior to connecting the water supply, ensure supply lines are flushed. Particles can clog filter and result in malfunction. Excessive particles from supply lines may require installing a separate efficient filter.

Step 1 Attach faucet to deck (1 hole)

Single hole mount without deck plate

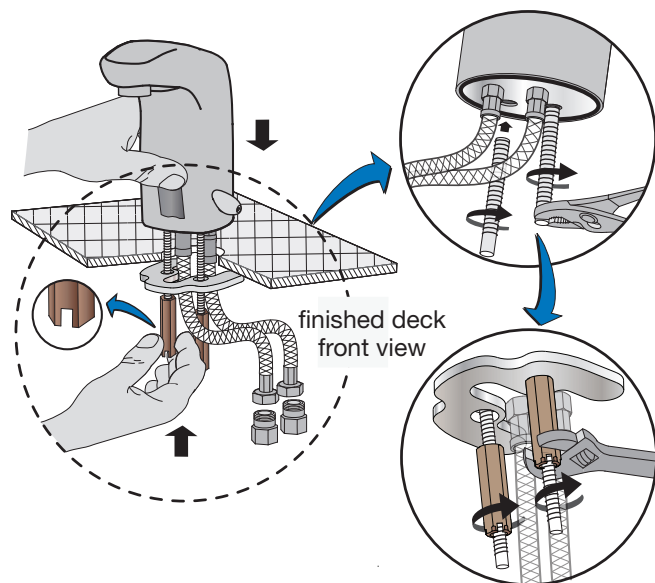

Step 1 Attach faucet to deck (3 hole)

Three hole mount with deck plate

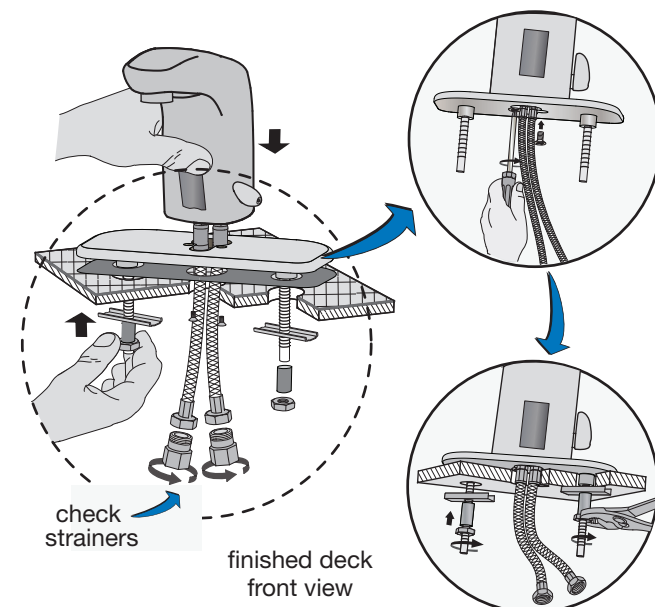

Step 2 Connect water supply line

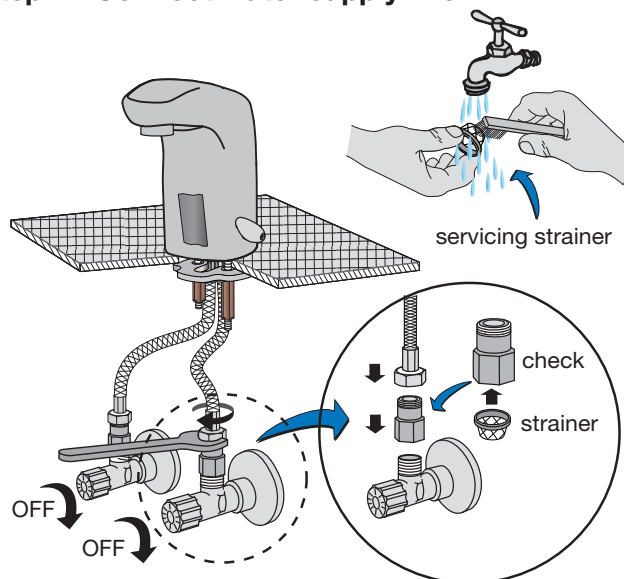

Step 3 Modify faucet for preset tempered hot cold supply (Config option #2 only)

- Remove temperature control handle and limit stop.
- Re-insert handle to adjust supply temperature.
- Remove handle and replace with push plug.

Step 4 Modify faucet for single supply with pre-mixed water (Config option #3 only)

- Turn temperature control handle counter clockwise to the maximum cold position.
- Remove temperature control handle and replace with push in plug.
- Remove the flexible hot water supply hose from base of faucet. (Note: left hand thread)
- Screw plug in place of supply hose into base of faucet.
- Attach single cold supply hose to pre-mixed supply.

Step 5 Test operation and check for leaks

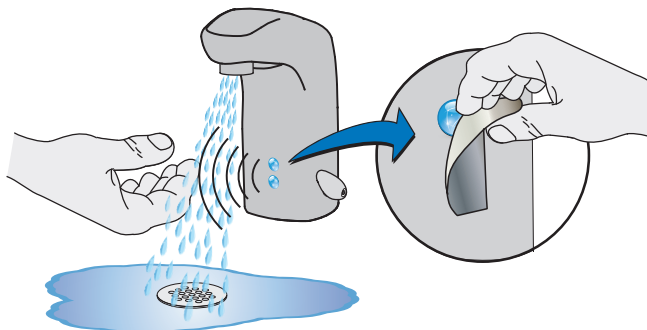

Limiting water temperature

Using Temperature adjustment handle

- Remove temperature adjustment handle.
- Set maximum water temperature limit by turning handle limit stop clockwise (CW).
- Increase maximum water temperature by turning handle limit stop counter clockwise (CCW).
- Re-install temperature adjustment handle.

Adjusting preset water temperature (config #2)

- Remove temperature adjustment handle plug.
- Adjust the maximum water temperature limit by inserting handle into faucet and turning counter clockwise (CCW).
- Increase temperature by turning handle clockwise (CW).
- Remove handle and re-install plug.

Operation

Sensor recognition range is factory preset at 1/2 - 4 inches

Place hand under faucet, water will flow automatically for 10 seconds and shut off.



Auto shut-off time is factory preset at 1/2 to 1 second

Remove hands, water will stop automatically within 1/2 to 1 second.



Security OFF after 10 seconds

Faucet will automatically shut off after continuous water flow for 10 seconds.



Weak or dead battery

LED will flash to signal battery is getting weak and should be replaced soon.



Troubleshooting

Sensor eye is blinking

- Indicates battery is weak and needs to be replaced.

No water flow

- Check water supply to the faucet.
- Clean around photo cell sensor area.
- Check for loose battery connections.
- Replace the solenoid valve.
- Replace the sensor.

Water flow is weak

- Water supply stops are not fully open.
- Clean aerator and check strainer on end of supply line(s). Excessive clogging may require installing of separate efficient filter into supply line.

Water flow from spout fails to turn off

- Sensing range may be too low. Clean around photo cell sensor area.
- Clean solenoid valve membrane or replace solenoid valve.

Water temperature can't be adjusted

- Clean the check strainer on end of supply line(s).
- Clean or replace the mixer.

Faucet care

Cleaning surface finish

- Block sensor with plastic cleaning cover to prevent faucet from turning on while cleaning.
- Clean finish area by using mild soap and water or non-abrasive cleaner and then rinse immediately. A non-abrasive wax may be used to preserve finish area.

Precautions

- Ensure sensor is not damaged through impact or scratches.
- Ensure sensor is not blocked or disturbed by any object within its detection range.
- Ensure that no strong light source is aimed directly at sensor or through a mirror.

Risk of Freezing

When installing the faucet in a location where the temperature may fall below freezing, the entire system must be drained of water to prevent damage in freezing weather.

- Turn off water supply.
- Disconnect all flexible hoses.
- Drain all parts and hoses of water.

Dimensions *Ultra-Sense Lavatory Faucet, S-6080*

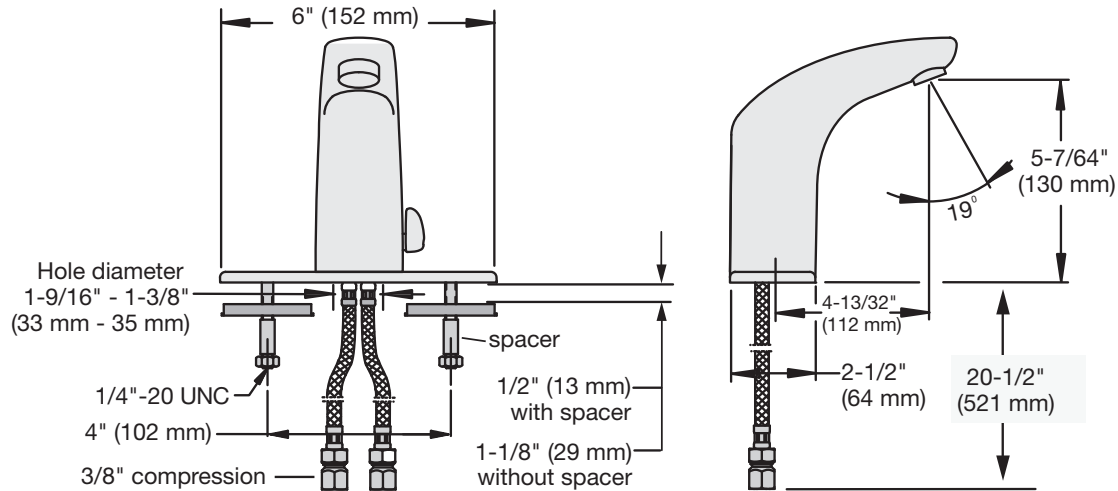





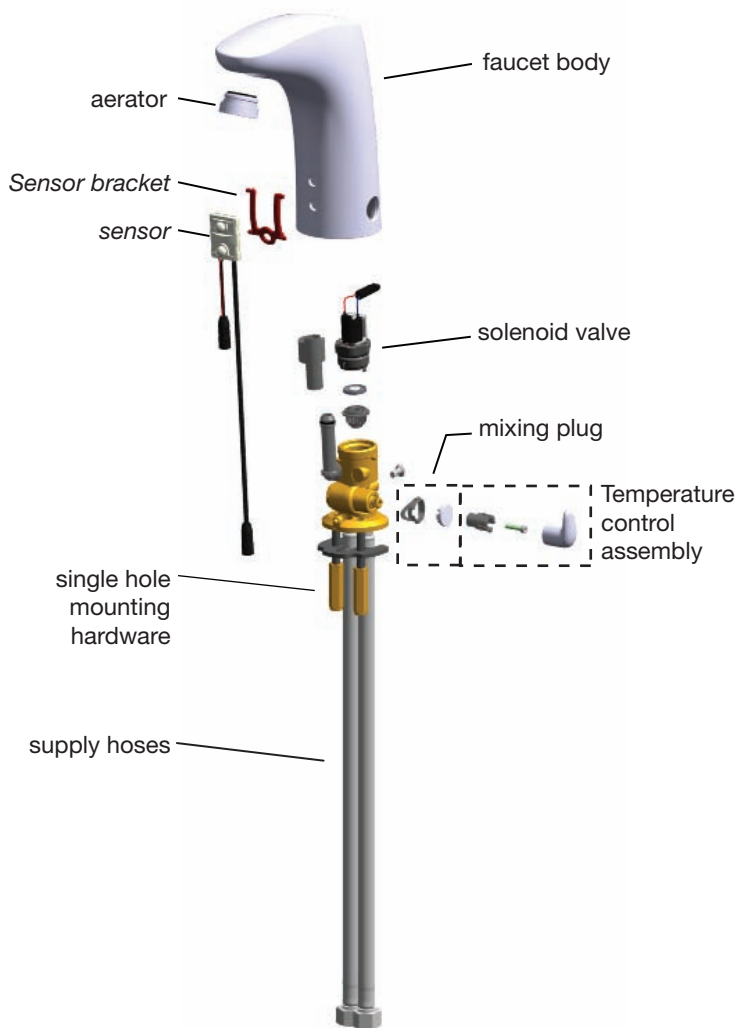

Note: Dimensions subject to change without notice.

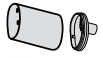
Parts Assembly *Ultra-Sense Lavatory Faucet, S-6080*

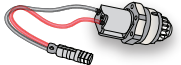

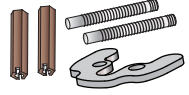
Replacement Parts

Part Number	Item
SF-241	Battery container and red removal paddle 
SF-2CR5	6v Lithium battery, 2CR5 
SF-240	Solenoid kit with membrane 
SF-245	Sensor kit with mounting brackets 
SF-186 SF-181	Check / strainer kit <ul style="list-style-type: none"> ▪ for flex hose ▪ for copper tubing, (option -LST) 
SF-158	Single hole mounting kit 
SF-125	Vandal protective aerator with removal tool #LL-60K <ul style="list-style-type: none"> ▪ 1.5 gpm (5.7 L/min) 
LN-100 LN-217	Vandal protective laminar flow non-aerated spray outlet with removal tool #LL-60K <ul style="list-style-type: none"> ▪ 0.5 gpm (1.9 L/min) ▪ 1.5 gpm (5.7 L/min) 

Ordering replacement parts:

Call Symmons customer service at (800) 796-6667, (781) 848-2250 M-F 7:30 am - 7:00 pm EST or check our website at www.symmons.com for a list of Symmons distributors.