



# LASER CLEAN HEATING SYSTEM/VENTED HEATER INSTALLATION AND OPERATION INSTRUCTIONS



## LASER CLEAN VENTED MODEL **Laser 60AT** (Type D)



**IMPORTANT**

READ AND UNDERSTAND INSTRUCTIONS BEFORE INSTALLING OR USING HEATER.  
RETAIN INSTRUCTIONS FOR FUTURE REFERENCE. CHECK LOCAL CODES FOR PERMITTED USE.

### CONTENTS

SECTION A:	SECTION G:
Specifications ..... 2	Troubleshooting..... 14
Safety Features ..... 3	SECTION H:
SECTION B:	Long Term Storage..... 16
Safety Tips for Operation ..... 4	SECTION I:
SECTION C:	Installation
Fuel Guide ..... 5	Tools Needed for Installation ..... 17
SECTION D:	Standard Installation Parts ..... 17
Operating Controls and Part Names ..... 6	Accessory Parts ..... 19
SECTION E:	Safety Tips for Installation ..... 22
Operation	Installation of Heater and Flue Pipe ..... 23
Before Ignition ..... 9	SECTION J:
Operation ..... 9	Fueling ..... 29
Turning Heater Off ..... 12	
SECTION F:	
Routine Maintenance ..... 12	

# SECTION A: SPECIFICATIONS

---

Model:	Laser 60AT
Heater Efficiency:	90% (1)
Heat Rating:	High - 30,000 BTU/h (8,800 Watts) Med - 21,000 BTU/h (6,160 Watts) Low - 12,000 BTU/h (3,520 Watts)
Fuel Consumption:	High - 0.230 gal/h (0.870 L/h) Med - 0.161 gal/h (0.609 L/h) Low - 0.095 gal/h (0.360 L/h)
Fuel System:	External tank (2)
Fuel Type:	ASTM D3699 1-K Kerosene, ASTM D396 Low Sulfur No.1 Fuel Oil, or ASTM D975 Ultra Low Sulfur Diesel (ULSD)
Dimensions (W × H × D): (Includes drip tray)	30" × 24" × 19" (76.0 × 60.8 × 48.3 cm)
Weight:	77 lbs. (35 kg) Empty
Vent Pipe Hole:	2-3/4" ~ 3" diameter (7.0 - 7.5 cm)
Maximum Length of Vent Pipe System:	10 ft. (3 m), 3 bends or less
Electrical Rating:	120 Volts AC, 60 Hz Preheat — 280W Burning — 60W
Typical Room Size (3):	1250 square feet (0°F) 1500 square feet (20°F)

(1) Heat and vaporized water are produced by the combustion process of this heater. This rating does not take into account heat loss due to condensation of water vapor.

(2) External tank to be purchased from local suppliers.

(3) 0° F Heat Load = 24 BTU/ft<sup>2</sup>/hr  
20° F Heat Load = 20 BTU/ft<sup>2</sup>/hr

Room size for which this heater is suitable will vary depending on outside temperature, house insulation, window size, and other factors.

## SAFETY FEATURES

Your Laser 60AT is equipped with the following safety features. Please familiarize yourself with these features. When your heater is extinguished due to a safety mechanism, be sure to identify and correct the problem.

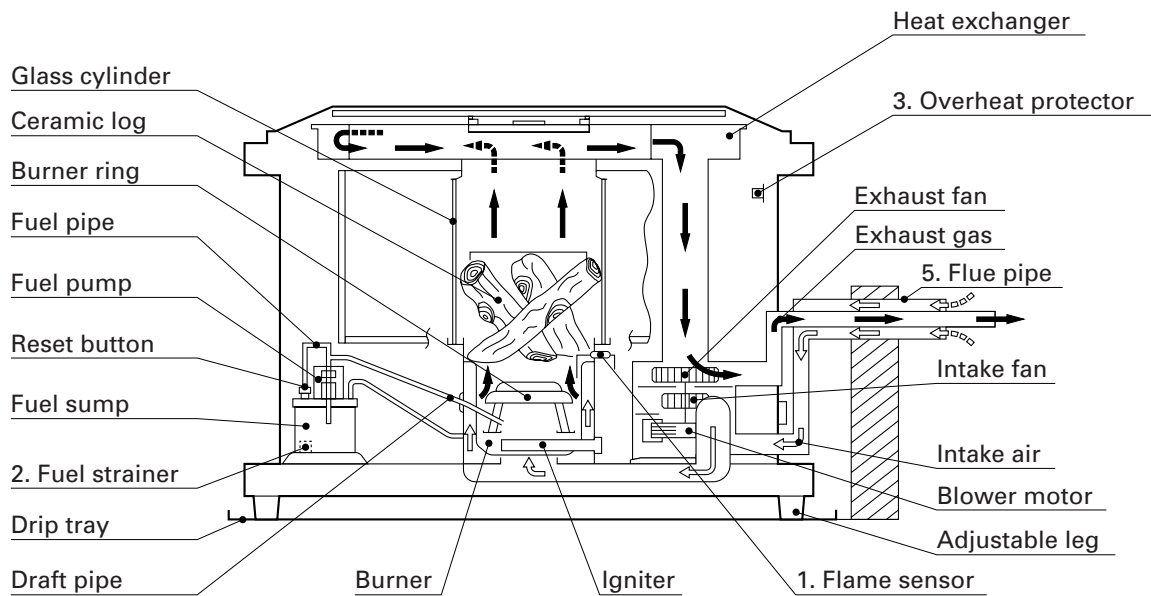

### 1. Flame Sensor

Heater will automatically stop all operations if ignition fails or if flame fails during combustion, in order to prevent fuel overflow. Error code will be displayed on the digital indicator.

### 2. Fuel Strainer

Special strainer catches any dirt or impurities present in the fuel before it is sent to the burner.

### 3. Overheat Protector

Automatically stops all operations if heater cabinet reaches abnormally high temperature due to motor malfunction or abnormal combustion, in order to prevent fire.

### 4. Power Failure Recovery System

If power fails during heater operation, heater will turn off. When power resumes, heater will automatically reignite to maintain the selected room temperature.

### 5. Fully Vented System

Flue pipe system provides outside air for combustion and vents all combustion products to the outdoors.

### 6. Fusible Link Valve

If a household fire should occur, bringing the fuel line or heater to extremely high temperatures, the fusible link valve will stop the fuel supply to the burner. This will prevent the fuel supply from the external tank continuing to flow into the house.

# SECTION B: SAFETY TIPS FOR OPERATION

**CAUTION:** Heater and vent pipe system must be properly installed before operation.  
Please follow instructions under "Installation", Section I.

1. Never use any fuel other than clear or red colored kerosene (ASTM D3699 1-K Kerosene, ASTM D396 Low Sulfur No.1 Fuel Oil, or ASTM D975 Ultra Low Sulfur Diesel (ULSD)). NEVER USE GASOLINE. Use of gasoline can lead to uncontrollable flames, resulting in destructive fire.

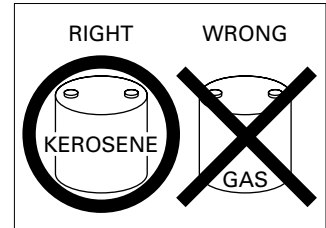

2. Due to high surface temperatures, keep heater away from children, furniture and clothing while in operation (See Page 24).

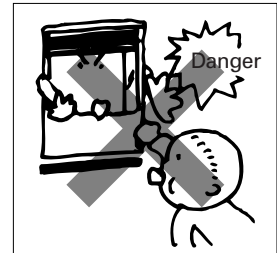

3. To prevent abnormal operation and prolong heater life, be sure to perform routine maintenance (See Pages 12–13).



4. Never store or transport kerosene in other than a metal or plastic container that is (1) acceptable for kerosene, (2) non-red in color, and (3) clearly marked, "KEROSENE", "No.1 FUEL OIL", or "ULTRA LOW SULFUR DIESEL". Never store fuel in the living space.

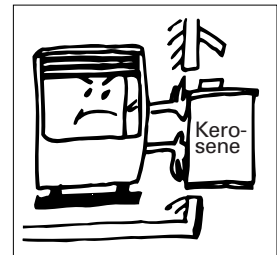

5. Operating Temperature Range  
Use heater within the range of temperatures indicated in the right figure.

Point A: If outside temperature -20°F than room temperature has to be 0°F or above

Point B: If outside temperature -45°F than room temperature has to be 60°F or above

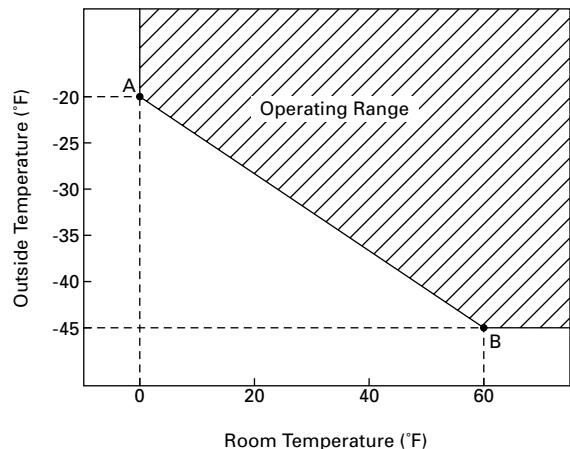

# SECTION C: FUEL GUIDE

The Toyostove Laser 60AT is designed for use with clear or red dyed ASTM D3699 1-K Kerosene, ASTM D396 Low Sulfur No.1 Fuel Oil, or ASTM D975 Ultra Low Sulfur Diesel (ULSD). Use of low-quality kerosene will cause burner performance to drop, leading to abnormal combustion and reduced heater life.

Purchase only ASTM D3699 1-K kerosene, ASTM D396 Low Sulfur No.1 Fuel Oil, or ASTM D975 Ultra Low Sulfur Diesel (ULSD) in non-red cans reserved exclusively for fuel and marked accordingly with the word "KEROSENE", "No.1 FUEL OIL", or "ULTRA LOW SULFUR DIESEL". Always store your fuel in a separate area from where you store gasoline for your power equipment to avoid accidental use of gasoline in your heater.

### What to Buy . . .

- ALWAYS : Clean and high-quality ASTM D3699 1-K Kerosene, ASTM D396 Low Sulfur No.1 Fuel Oil, or ASTM D975 Ultra Low Sulfur Diesel (ULSD).
- ALWAYS : Fuel free of contaminants, water or cloudiness.
- NEVER : Gasoline, alcohol, white gas, camp stove fuel or additives.
- NEVER : Yellow or sour-smelling fuel.



### How to Store It . . .

- ALWAYS : Store in a clean container, non-red in color, clearly marked KEROSENE, No.1 FUEL OIL, or ULTRA LOW SULFUR DIESEL.
- ALWAYS : Store away from direct sunlight, heat sources or extreme temperature changes.
- NEVER : In a glass container, or one that has been used for other fuels.
- NEVER : For longer than six months. Begin each heating season with fresh fuel; discard at the end of season.
- NEVER : In the living space.

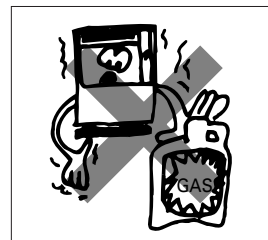

### Why It is Important . . .

Good, clean fuel is essential for safe and efficient heater operation. Poor quality or contaminated fuel can cause:

- Excess tar deposits on burner and flue pipe
- Incomplete combustion
- Reduced heater life

Use of a highly volatile flammable fuel such as gasoline can produce uncontrollable flames, creating a severe fire hazard.



Note: The fluidity of Ultra Low Sulfur Diesel becomes worse at temperatures of 21°F (-6°C) and below and can "gel". This condition may cause ignition failure. To prevent congealing it is recommended to use an additive with the fuel. Check with a fuel supply company for the proper additive and mix.

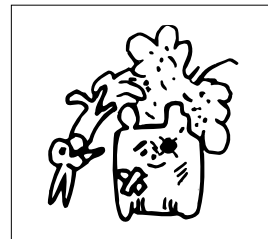
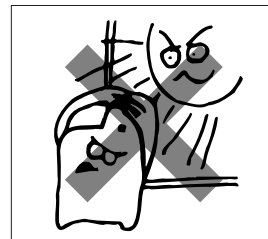

# SECTION D: OPERATING CONTROLS AND PART NAMES

Before using heater, familiarize yourself with the following operating controls and part names.

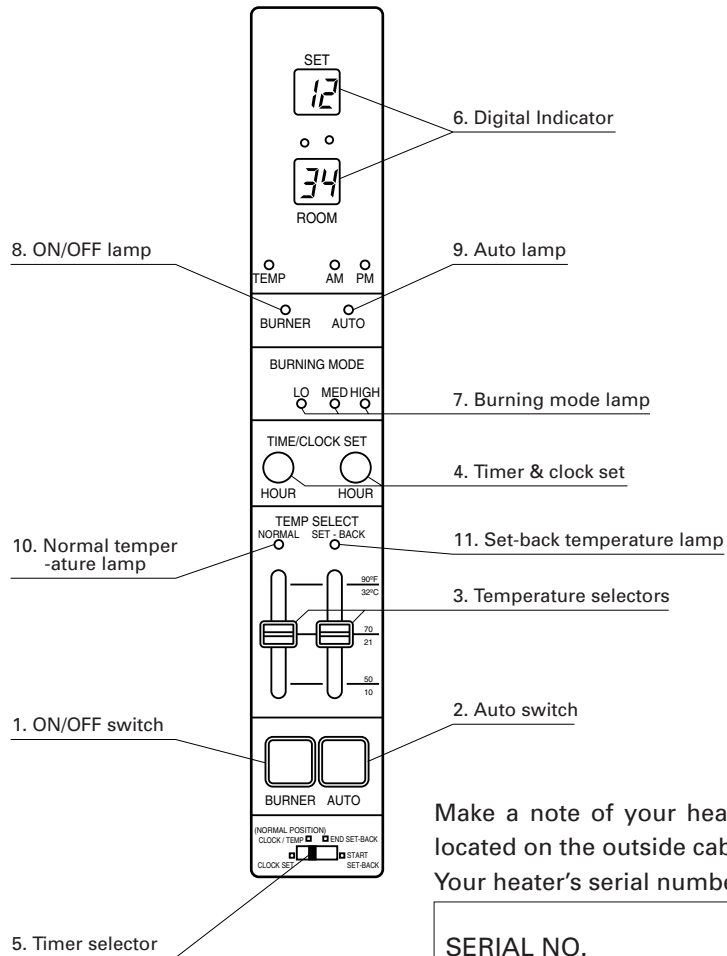
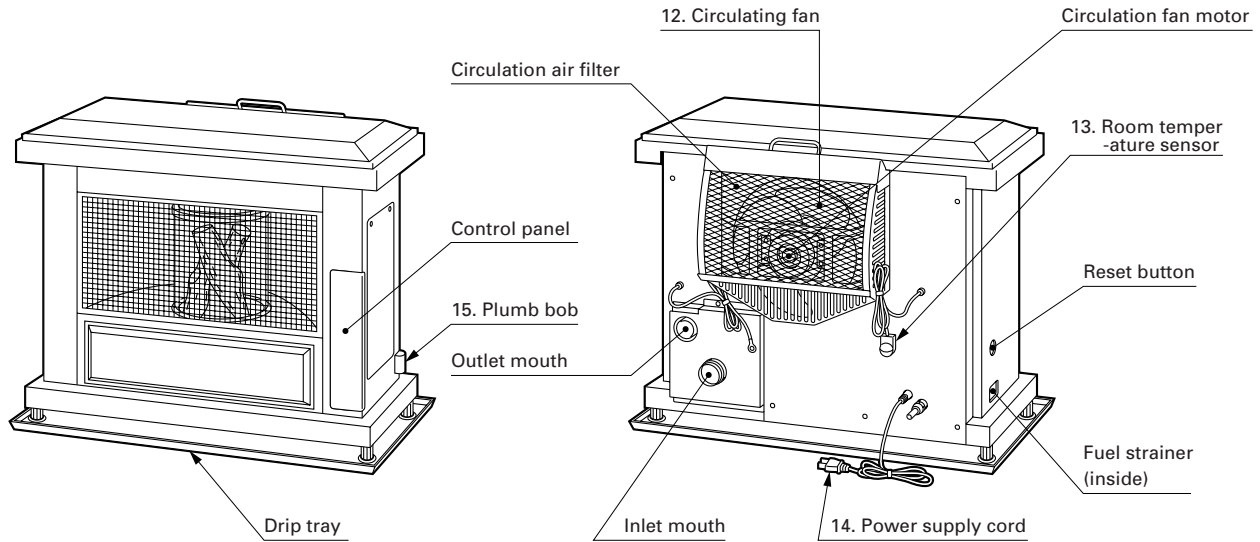

1. ON/OFF switch: Main switch which turns heater on and off. When switched on, heater begins operation and combustion starts after preheat period.
2. Auto switch: The switch turns automatic operation modes on and off which have been programmed into timer.
3. Temperature selectors: "NORMAL" and "SET-BACK" temperature selectors allow user to select desired temperature during manual or automatic operation.
4. Timer & clock set: Timer and clock set modes can be set by pressing hour or minute buttons.
5. Timer selector: Clock, clock set, "SET-BACK" mode, start time set and end time set can be selected by this switch.
6. Digital indicator: Displays clock, set temperature, room temperature and error code.
7. Burning mode lamp: Indicates whether heater is operating at high, medium or low combustion.
8. ON/OFF lamp: Lights when heater is in operation and flashes when heater is in prepurge or postpurge.
9. Auto lamp: Lights when automatic operation is in use.
10. Normal temperature lamp: Lights when heater runs with manual or "NORMAL" mode of automatic operation.
11. Set-back temperature lamp: Lights when heater runs with "SET-BACK" mode of automatic operation.
12. Circulating fan: Three-speed motor supplies high-capacity warm air flow during high combustion for heating room up quickly, and low or medium capacity warm air flow during low or medium combustion for maintaining comfortable room temperature.
13. Room temperature sensor: Constantly senses room temperature and supplies information to heater so that desired room temperature can be maintained.
14. Power supply cord: For use in 120V, AC electrical outlets only.
15. Plumb bob: Allows user to check if heater is positioned evenly.

### **INDICATOR LAMPS**

ON/OFF lamp	Flashing - Pre-heating, pre-purging and post-purging mode Lit - Heater in operation
AUTO lamp	Flashing - Power loss of more than 10 seconds Lit - Heater in operation at auto mode
LOW lamp	Lit - Heater in operation at low combustion
MED lamp	Flashing - Pre-purging mode (without flame) Lit - Heater in operation at medium combustion
HIGH lamp	Lit - Heater in operation at high combustion
NORMAL lamp	Lit - Heater in operation at normal mode
SET-BACK lamp	Lit - Heater in operation at set-back mode

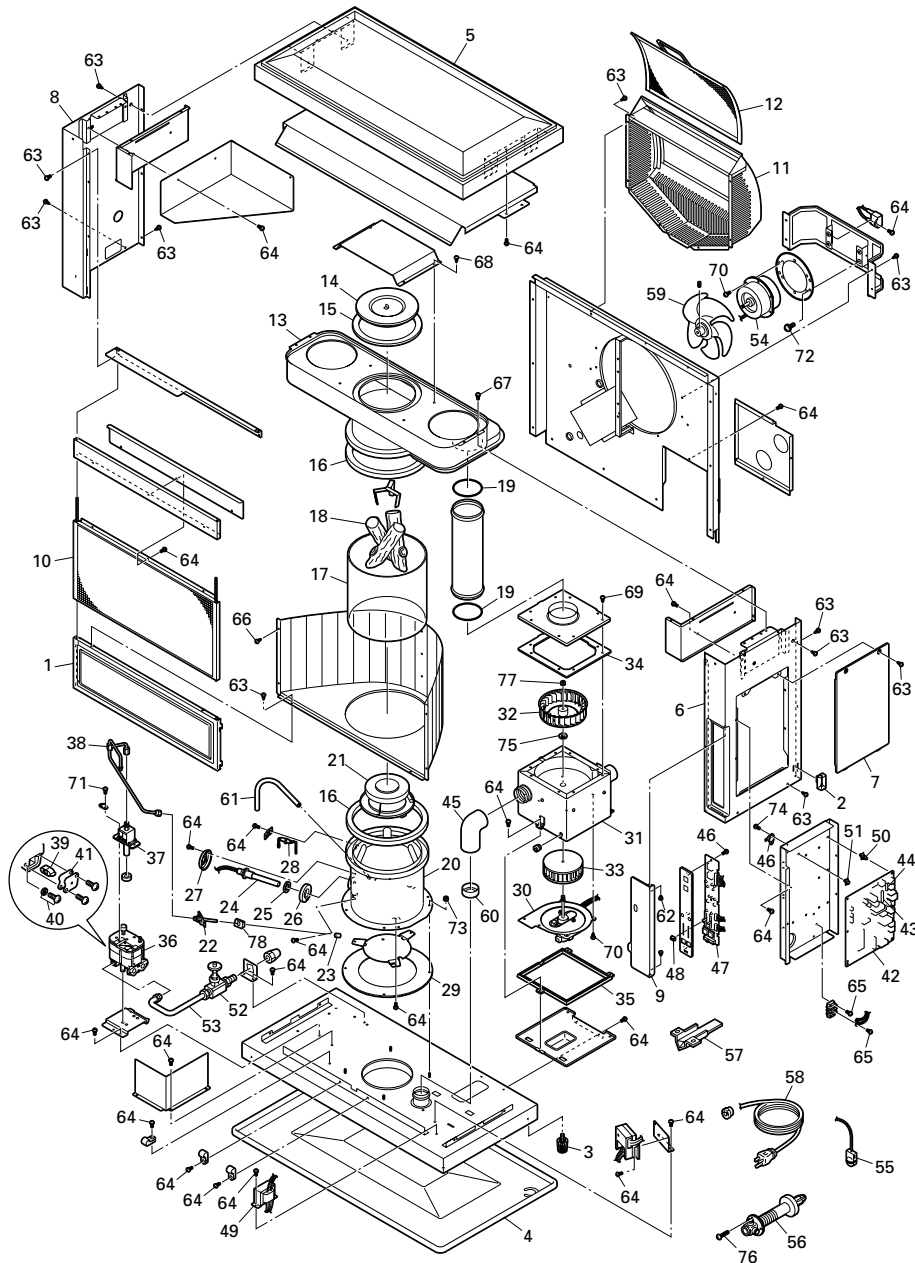

REF #	PART #	PART NAME	REF #	PART #	PART NAME	REF #	PART #	PART NAME
1	20479946	Front panel	28	20479911	Primary flame rod	55	20478373	Thermistor
2	20450007	Plumb bob	29	20475194	Burner gasket	56	20479891	Flue pipe
3	20479570	Adjustable leg	30	20479938	Blower motor assembly	57	20474925	Oil catch
4	20479929	Drip tray	31	20479948	Blower motor assembly with case	58	20479935	Power supply cord
5	20479960	Top plate	32	20478871	Blower motor exhaust fan	59	20475071	Circulation fan
6	20479963	Right side panel	33	20475883	Blower motor intake fan	60	20478366	Air damper (P25)
7	20479970	Access panel	34	20475875	Blower motor case gasket	61	20479987	Draft tube
8	20479964	Left side panel	35	20475878	Rubber mat	62	20474059	Holder A
9	20479931	Control panel door	36	20478534	Fuel sump	63	20479956	Screw AT1
10	20479903	Grille	37	20479919	Fuel pump	64	20474050	Screw C
11	20479972	Fan cover	38	20479941	Fuel pipe assembly	65	20476482	Screw B10
12	20479940	Circulation air filter	39	20478550	Fuel inlet strainer	66	20479958	Screw AT2
13	20479944	Heat exchanger	40	20475551	Drain screw with o-ring	67	20474051	Screw D
14	20479945	Canopy	41	20475552	Strainer gasket	68	20476452	Screw B2
15	20479955	Canopy gasket	42	20478512	Main circuit board	69	20475554	Screw 1Q
16	20479981	Glass cylinder gasket	43	20478378	Fuse A (10A)	70	20476454	Screw B4
17	20479949	Coated glass cylinder	44	20478379	Fuse B (5A)	71	20474053	Screw F
18	20479908	Ceramic log	45	20479983	Outlet adapter	72	20474055	Screw O
19	20475877	O-ring (P75)	46	20478306	High limit switch (=20474506)	73	20474057	Flange Nut
20	20479942	Burner assembly	47	20479976	Indicator lamp circuit	74	20450120	Screw for igniter unit
21	20479943	Burner ring	48	20479901	Knob for temp selector	75	20475874	Washer for blower motor
22	20478026	Fuel nozzle	49	20479917	Transformer	76	20474272	Screw M
23	20478383	Fuel nozzle gasket	50	20479914	PCB support	77	20479957	Nut J
24	20479518	Igniter	51	20479915	PCB support (S)	78	20479885	Outside nozzle gasket
25	17185580	Igniter gasket	52	10005597	Fusible link valve	79	20479994	Instruction manual
26	20474921	Igniter guide gasket	53	20479952	Leveler fuel pipe	80	20479997	Carton
27	20474920	Igniter cover	54	20479969	Circulation fan motor			



# SECTION E: OPERATION

## BEFORE IGNITION

### 1. Open the Valve(s)

Open the valve(s) of the external fuel tank.

### 2. Start the Fuel flow

If using heater for the first time, or after heater has been out of fuel, press the red reset button once for a period of one second in order to send fuel to the fuel sump.

Note: Make sure there is no fuel leakage from the fuel line or joints.  
Also make sure fuel tank is not too high. See installation instructions.

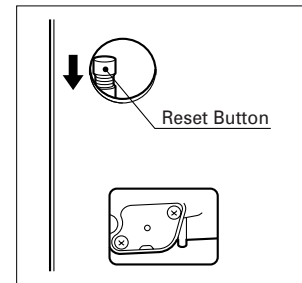

### 3. Plug in the Heater

Plug heater into a 120V AC electrical outlet.

Note: Do not connect to an outlet shared with other appliances.

### 4. Set Clock

Important: Clock on the heater always must be set to current time.

- A. Position timer selector to "CLOCK SET".
- B. Press "HOUR" and "MINUTE" button of TIMER/CLOCK SET to correct time.

Important: Check for the AM or PM indicators, to insure the correct time.

Note: "HOUR" or "MINUTE" button will change the time every one (1) unit. Holding the button continuously will cause the time to change rapidly.

Note: In the event of a power failure over ten (10) seconds, all clock and timer settings are cancelled. Digital indicator will flash "PM 12:00" when heater is off, or "AUTO" lamp will flash when heater is on and in automatic operation, after is power is restored. However, no indications when heater is in manual operation. At this point, you need to reset all time and set-back functions.

- C. Position timer selector to "CLOCK/TEMP (NORMAL POSITION)" after clock setting is completed. Current time will be shown on digital indicator.

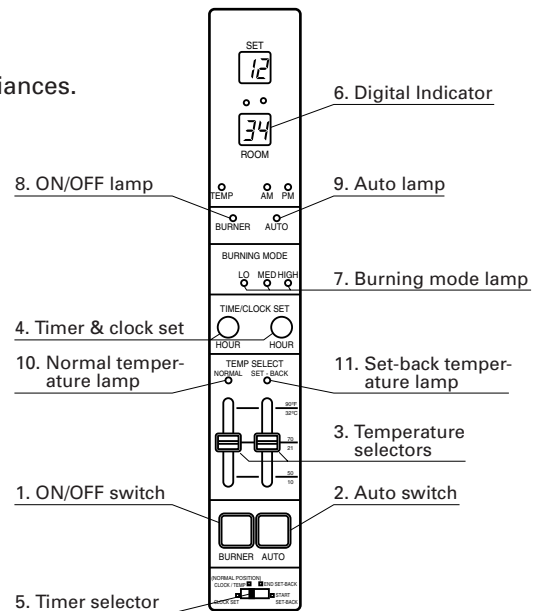

## OPERATION

Operation of Laser Heater can be controlled manually by the user - "MANUAL" operation (NORMAL mode only) or run automatically by the programming - "AUTOMATIC" operation (NORMAL mode and SET-BACK mode).

### MANUAL OPERATION

"MANUAL" operation means that the set-back will not be in use but in "NORMAL" mode.

Operation of the heater is under the direct control of the user ("AUTO" switch is off). Heat output will, however, be automatically adjusted in accordance with the room temperature registered by the temperature sensor.

**1. Select Manual Operation**

Press the "AUTO" switch to "OFF" position.

**2. Turn Heater ON**

A. Push in ON/OFF switch to "ON" position. The current room temperature and the set temperature will be shown on the digital indicator. ON/OFF lamp will start to flash and then blower motor and ignition will start.

Note: Heater will not start when room temperature is higher than the desired temperature setting.

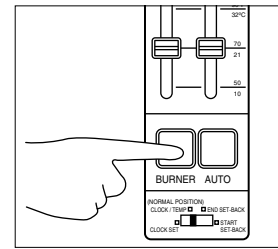

B. Burning mode lamp "MED" will start to flash after approx. 3 - 9 minutes and ignition will take place. (\*) After ignition, burning mode lamp "MED" will change from flashing to continuous. And, after 10 seconds, burning mode lamp will turn to "LOW" and heater will start "LOW" burning mode. Circulation fan will turn on after approx. 3 minutes.

Note: (\*) Pre -heating depends on the room temperature.

Room temperature: below 34°F - 9 minutes  
 34°F - 61°F - 6 minutes  
 over 61°F - 3 minutes

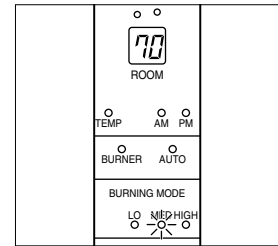

C. Heater will operate at "LOW" or "MED" burning mode for approx. 6 minutes after ignition, regardless of temperature control setting. Heater will not go into "HIGH" burning mode while the prepurging is in effect. After this period, output can be adjusted as desired by using the "NORMAL" temperature selector as directed in following instructions.

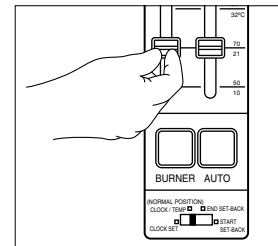

**3. Adjusting Room Temperature**

A. Slide "NORMAL" temperature selector to set the room temperature desired. The temperature control should be set at the position you find most comfortable.

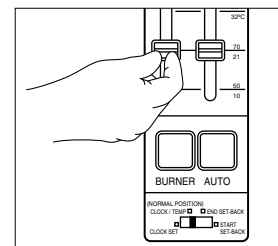

Note: Desired temperature setting will be displayed on the digital indicator when you set the room temperature.

Note: The scale on temperature selector is just for your reference. The figures on the digital indicator and on the scale may not match exactly; This is normal.

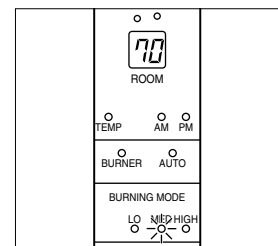

B. Burning mode will be regulated automatically in accordance with the room temperature registered by the room temperature sensor. Heater will be operated at "HIGH" burning mode until room temperature reaches the selected temperature level.

C. When room temperature reaches the selected setting, heater will automatically shift to "MED" or "LOW" burning mode to maintain the desired temperature.

When room temperature exceeds the selected setting by approx. 4°F, the heater will automatically shut off. As room temperature drops, the heater will automatically re-start to maintain the desired temperature.

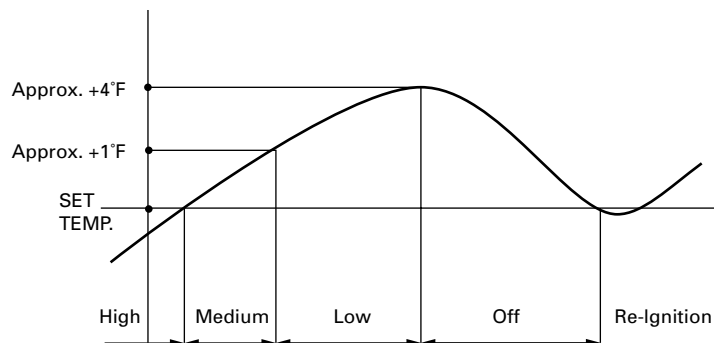

## AUTOMATIC OPERATION

"AUTOMATIC" operation is established by programming the time/temperature settings for specific time, "SET-BACK" mode operation will be programmed in a 24-hour period. It is designed for energy efficiency by using a lower temperature setting, generally at night.

**Ex.**

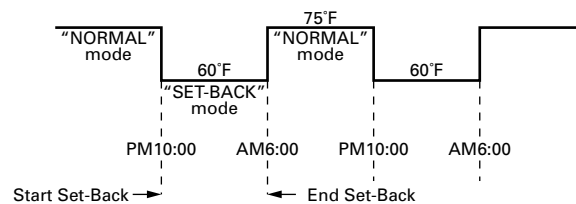

### 1. Set Start Time of "SET-BACK" Mode.

A. Slide the timer selector to "START SET-BACK".

B. Press "HOUR" and "MINUTE" button of TIMER/CLOCK SET to set desired start time.

Note: When setting "SET-BACK" time, the "MINUTE" button will advance time by ten (10) units.  
(Ex. 10:00, 10:10, 10:20, etc.)

C. Start time of "SET-BACK" mode will be shown on digital indicator. (Ex. PM 10:00)

### 2. Set End Time of "SET-BACK" Mode.

With the timer selector slide switch in the "END SET-BACK" position, program the end time as described above. (Ex. AM 6:00)

Important: Always return timer selector to "CLOCK/TEMP (NORMAL POSITION)" after settings.

### 3. Set Room Temperature.

Slide "NORMAL" temperature selector and "SET-BACK" temperature selector at the position you desire. (Ex. "NORMAL" — 75°F, "SET-BACK" — 60°F)

Note: The temperature setting currently being used is displayed on the digital indicator. To view and set the Set-Back temperature setting, press the "MINUTE" button for more than three (3) seconds. The display will go back to the Normal temperature setting after ten (10) seconds.

### 4. Push in AUTO switch to "ON" position.

### 5. Turn Power ON.

Press ON/OFF switch to "ON" position. ON/OFF lamp will start to flash and AUTO switch lamp will light. And then blower motor and ignition will start.

Note: SET-BACK OPERATION IRREGULARITIES: If a heater is switched "OFF"; if the "AUTOMATIC" operation is switched off; or there is a power interruption while the unit is operating in the "SET-BACK" mode, the "SET-BACK" mode may be temporarily disabled until the next Start Set-Back time.

## TURNING HEATER OFF

Press ON/OFF switch to "OFF" position. (AUTO lamp and temperature lamp will go out. Burning mode lamp will flash until flame disappears.) Circulation fan and blower motors continue to run for approx. three (3) minutes to cool down the heater. Make sure ON/OFF lamp goes out when the fan stops.

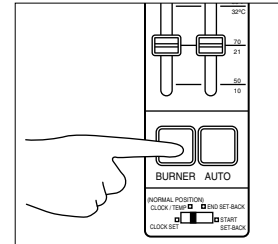

Note: If ON/OFF switch is pressed to "ON" position during the cool down period, the heater will automatically re-start at the end of cool down period.

Note: Disconnect the heater plug from the electrical outlet after the power lamp has turned off if the heater will go unused for a prolonged period. The plug should also be disconnected during electrical storms.

Note: Heater may also be shut down by lowering the setting on the temp. selector thermostat(s) because heater goes into "OFF" cycle.

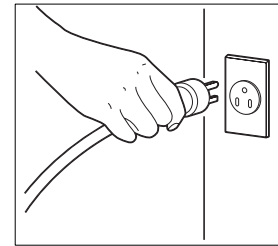

## MANUAL COMBUSTION

Important: This feature is for testing purpose only!

This heater also can be kept burning at desired combustion mode (High, Medium or Low) manually, regardless of room temperature.

1. Press the "HOUR" button and "MINUTE" button at the same time for more than three (3) seconds when ON/OFF switch is "ON".
2. P1, P2 or P3 will be displayed on the Digital Indicator;
  - P1 = Low mode
  - P2 = Medium mode
  - P3 = High mode

Then select desired combustion mode by pressing "MINUTE" or "HOUR" button. "MINUTE" button changes combustion mode to higher, "HOUR" button changes combustion mode to lower.

3. To clear, press the "HOUR" button and "MINUTE" button at the same time for more than three (3) seconds until normal temperature display returns.

## SECTION F: ROUTINE MAINTENANCE

**CAUTION:** Be sure to unplug heater before performing any checks or cleaning.

**CAUTION:** Allow heater to cool completely before cleaning or maintenance.

FOR OPTIMUM HEATER PERFORMANCE, THE PARTS SHOWN BELOW SHOULD BE CLEANED REGULARLY:

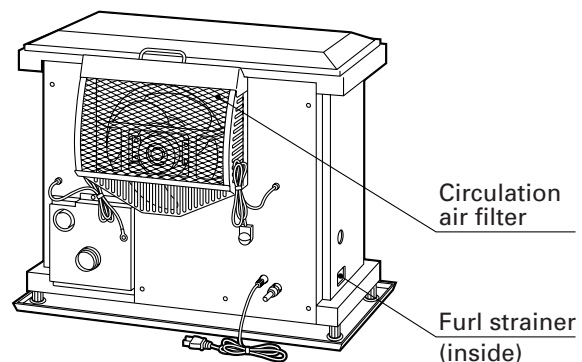
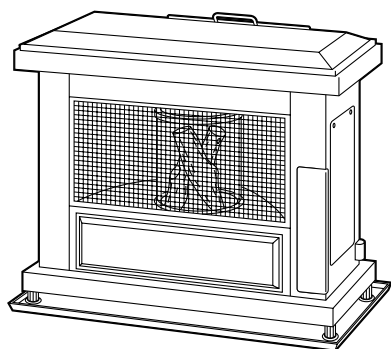

**1. Clean Louvers (ONCE A WEEK)**

Dust and stains should be wiped off louvers with a damp cloth.

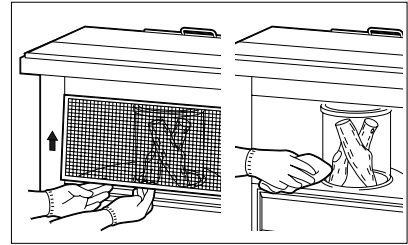

**2. Clean Circulation Fan Cover (ONCE A WEEK)**

Remove only dust or pet hair from the cover on the back of the heater.

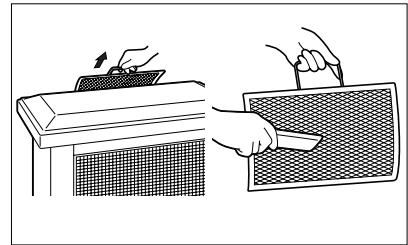

**3. Check for Fuel Leaks (REGULARLY)**

Make it a habit to check for any sign of fuel leakage along the fuel line and at all joints. Fuel leaks may lead to risk of fire.

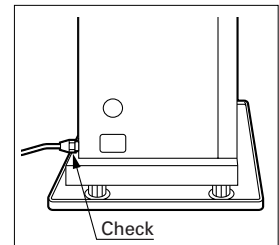

**4. Check Flue Pipe Area (ONCE A WEEK)**

Check the flue pipe joint to make sure connection is firm. Use a vacuum cleaner to remove any dust or pet hair.

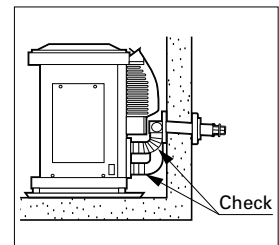

**5. Clean Fuel Strainer (ONCE A MONTH)**

The strainer of the fuel sump should be cleaned once a month and before storing heater at the end of each season.

- (a) Close the valve(s) of the separate fuel tank.
- (b) To catch the fuel which will drain out, set the oil catch below the strainer cover, with a small container under it.
- (c) Loosen the two screws from the strainer cover and remove.
- (d) Remove the strainer and wash with kerosene.
- (e) Return the strainer to its original position. Replace strainer cover and screw to secure.
- (f) Wipe away any spilled fuel.
- (g) Open the valve(s) of separate fuel tank. Check for fuel leakage.

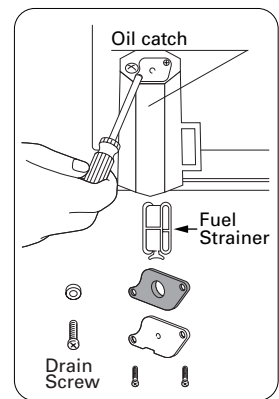

Note: Be sure to unscrew the drain screw to remove all remaining fuel from the fuel sump at the end of each season.

**6. Recommended Periodic Maintenance**

As a state-of-the-art furnace, your heater requires periodic inspection and service by an authorized technician to insure optimum, trouble free performance. This inspection should include: a combustion check; flue pipe check; burner assembly check; cleaning all necessary parts and replacing gaskets as needed. Please ask your authorized Toyostove dealer for details and scheduling. When using Ultra Low Sulfur Diesel (ULSD) the heater should be serviced at least every two years because the distillation of ULSD is heavier than 1-K Kerosene and No. 1 Fuel Oil. When using 1-K Kerosene or Low Sulfur No. 1 Fuel Oil your heater can be serviced less frequently.

# SECTION G: TROUBLESHOOTING

## NOTE BEFORE REQUESTING FOR REPAIR AND SERVICES

The following symptoms are normal during operation of the heater.

	CONDITION	REASON
When heater is started or extinguished.	White smoke or smell at initial use after purchase.	Machine oil or dust burns of the surfaces of the burner or heat exchanger.
	Flames flashing for a few minutes after ignition.	The burner is cold and igniter is kept running for a while after ignition.
	Occasionally makes "cracking" noise when heater is ignited or extinguished.	Expansion and shrinkage of metal parts when they are heated or cooled.
	Warm air will not blow as soon as ignited.	To prevent uncomfortable cool air from coming out at the beginning, circulation fan start up is delayed.
	Audible chugging sound from fuel pump when started first time or after running out of fuel.	Air is in the pump. However, noise should stop within 1 minute.*
When heater is in operation.	"Ticking" noise.	Noise of fuel pump in operation. Normal.
	Part of the heat chamber or the heat exchanger is heated to a cherry red color.	Normal.
	Occasional yellow flickering in blue flame.	Normal.

\*If sound from fuel pump does not decrease and heater shuts off, check:

1. Push red reset button on fuel sump. DO NOT hold down.
2. Insure that all valves are open and filter is clear.
3. Insure external fuel tank has fuel and filters are clean.

## AUTOMATIC CLEANING SYSTEM

Heater will automatically clean igniter for ten (10) minutes every day at 2:00 a.m. and display "CL:10" on Digital Indicator if heater is running at that time.

## MANUAL CLEANING SYSTEM

Heater will clean igniter for ten (10) minutes manually.

1. Press the "HOUR" button and "MINUTE" button at the same time for more than three (3) seconds when ON/OFF switch is "OFF".
2. Display will appear "CL:10" on Digital Indicator. Cleaning will begin and end without any additional input.

Note: Cleaning igniter is important to prolong igniter life. It is recommended that the igniter be cleaned once a week.

Should problems arise during operation or ignition, use this chart to determine the cause and the proper steps to take. Be sure to unplug heater and allow to cool completely before taking corrective measures. In the event that heater should extinguish itself, without any action or your part, you should look to the digital indicator for any of the following error codes.

DISPLAY/LAMP	PROBLEM	CAUSE	SOLUTION
	POWER LAMP FAILS TO TURN ON	Disconnected power plug Circuit board malfunction	Plug into 120V AC outlet. Consult your dealer.
EE2 EE2 EE2  EE2 EE2 EE2  EE8	NO IGNITION*	Out of fuel Fuel tank valve closed Air pocket in fuel line  Clogged flue pipe Clogged fuel strainer Igniter, circuit board, flame sensor or fuel pump malfunction Blower motor malfunction	Check fuel gauge on fuel tank; refuel. Open valve by turning counterclockwise. Push reset button on the fuel sump, located right inside, once. Clean flue pipe. Clean fuel strainer (See page 13). Consult your dealer.  Consult your dealer.
EE6 EE6 EE6 EE6 EE6 EE6 EE8	EXTINGUISHED AFTER IGNITION	Air pocket in fuel line  Out of fuel High limit switch activated  Fuel flow obstruction Tank too high Fuel sump valve malfunction Flame sensor malfunction Blower motor malfunction	Push reset button on the fuel sump, located right inside, once. Check fuel gauge on fuel tank; refuel. Clean circulation fan cover, remove any obstructions. Consult your dealer. Re-locate fuel tank. Consult your dealer. Consult your dealer Consult your dealer.
	POOR COMBUSTION/ NOISY COMBUSTION	Soot buildup in flue pipe Burner ring not properly seated Altitude too high (See page 23.)	Clean out any soot. Consult your dealer. Consult your dealer.
EE10	DOES NOT EXTINGUISH	Possibly excess fuel in burner Flame sensor malfunction	Consult your dealer. Consult your dealer.
	ODOR	Leaking flue pipe Fuel leakage  Faulty packing or gasket in combustion area	Tighten all flue pipe connections. Tighten all fuel line joints. Wipe away any fuel drippage. Consult your dealer.
Hi		Room temp is over 95°F. Incorrect location of room temp sensor	Correct the location of the room temp sensor.
Lo		Room temp is lower than 14°F. Room temp sensor malfunction or disconnected	Check room temp sensor.
Low/Med/ High lamps flashing at the same time	DOES NOT EXTINGUISH	Possibly excess fuel in the burner or flame sensor malfunction (miss detection)	Consult your dealer.

**WARNING:** Do not re-use the unit until the cause of the “EE10” code has been determined.

If the corrective measures outlined above do not solve the problem, please consult your TOYOSTOVE dealer.

\*Note: If the unit fails 3 times after checking all causes listed, DO NOT CONTINUE turning the power switch on and off. (Consult your dealer.)

## SECTION H: LONG TERM STORAGE

---

At the close of each heating season, or when you do not plan to use your heater for an extended period, the following procedures are recommended.

1. As the end of the season approaches, calculate your fuel purchases so that you can use up all the fuel you have on hand. When fuel is stored for over six months, its quality may deteriorate. The use of such fuel will have an unfavorable effect on heater operation.
2. If your heater needs any service or repair, now is the time to call your dealer and get it done before storage. That way your heater will be ready for immediate use when the next heating season begins.
3. If you plan to store your heater in place,
  - (a) Disconnect power supply.
  - (b) Close the main tank valve.
  - (c) Remove all fuel from the fuel sump and clean the fuel strainer.  
(See page 13.)
  - (d) Wipe off any stains or dust on heater with a damp cloth, then wipe once again using a dry cloth.
  - (e) Cover heater completely with a large plastic bag to protect from dust.

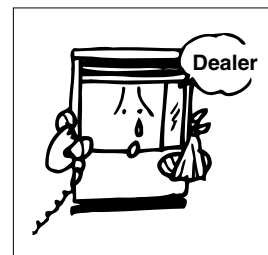



# SECTION I: INSTALLATION

---

## TOOLS NEEDED FOR INSTALLATION

### Tool

Phillips Head Screwdriver  
 Electric Drill  
 Hole Saw, 2-3/4 to 3" diameter

### Use

Installation of flue pipe, etc.  
 Drilling hole in wall for flue pipe  
 Making hole in wall for flue pipe

## STANDARD INSTALLATION PARTS

The following standard installation parts are enclosed with heater. For alternate installation methods, you may need to purchase additional accessories which are available from your TOYOSTOVE dealer. See "Accessory Parts", page 19.

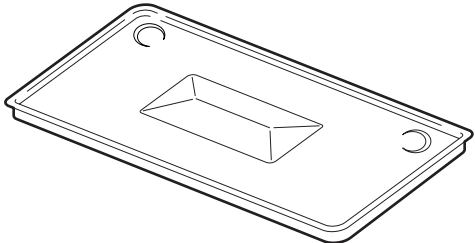
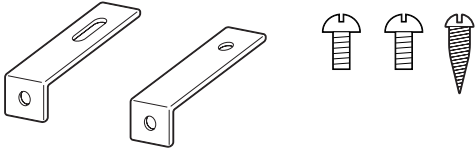
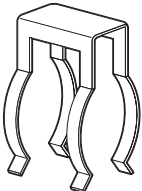
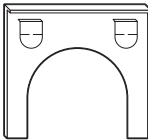
 <p>Drip Tray (1) (PART #20479929)</p>	 <p>Wall Brackets (2 sets) (PART #20474962)</p>
 <p>Pipe Holder (1) (PART #20474963)</p>	 <p>Pipe Stopper (1) (PART #20474964)</p>



(3)

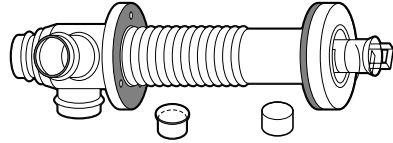

Flue Pipe (1) (PART #20479891)  
 Exhaust Air Cap (1) (PART #20479845)  
 Intake Air Cap (1) (PART #20474949)  
 Screw 4G (3) (PART #20474985)

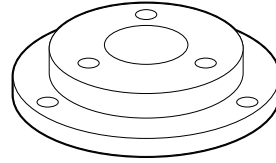

Spacer (1) (PART #20478967)  
 Screw M (3) (PART #20474272)



(3)

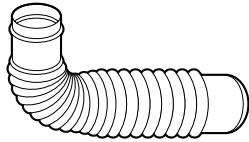

Bent Joint (1) (PART #20474984)

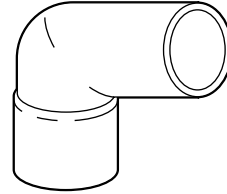

L-Shaped Hose (2) (PART #20474975)

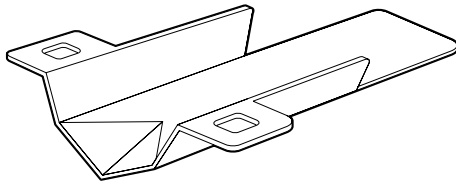

Oil Catch (1) (PART #20474925)

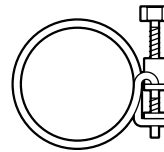

Hose Band (2) (PART #20474977)

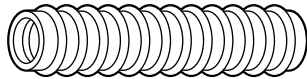

Inlet Hose (1) (PART #20474951)

## ACCESSORY PARTS

The following accessory parts are available for use in non-standard installation of the Laser 60AT. After giving careful consideration to your desired heater and flue pipe locations and fueling system, consult your TOYOSTOVE dealer to purchase the necessary accessory parts.

Important: Use only genuine TOYOSTOVE parts for your heater. Use of unauthorized generic or other brand parts can severely reduce performance and safety, and will invalidate factory warranty.

Accessory	Part No.	Application
Extension pipe kit (L)*	20479898	Extends pipe system by 61-3/4 to 78-3/4"
Extension pipe kit (M)*	20479897	Extends pipe system by 22-1/2 to 39-3/8"
Extension pipe kit (S)*	20479896	Extends pipe system by 12-5/8 to 19-5/8"
L-Shaped exhaust joint*	20479861	For 90 degree bend in exhaust pipe
Fuel lifter pump Model OPT-91UL	20477500	Used to lift fuel to heater when fuel tank is located underground or outdoors in a position lower than the heater. With automatic recovery.
External Fuel Supply Installation Kit	10005098	For installation of external tank system
Pressure reducing valve	10005099	See Note on page 30.

\* Total length of extension pipe between heater and flue pipe must be no greater than 10 ft. No more than three bends may be used in extension pipe.

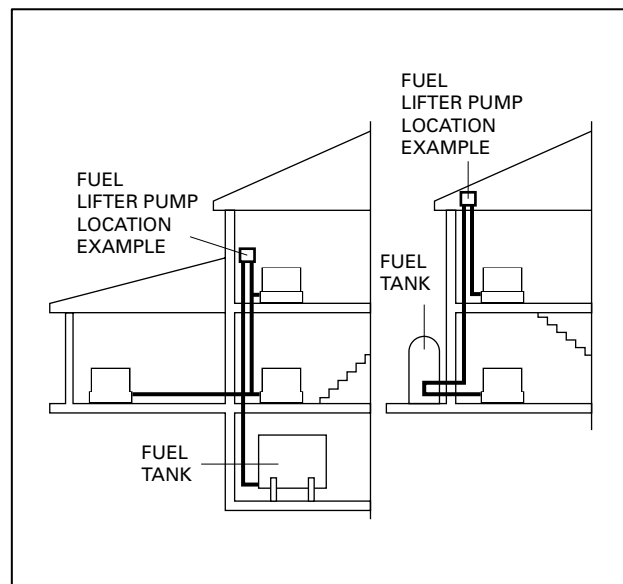
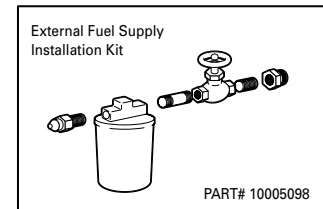
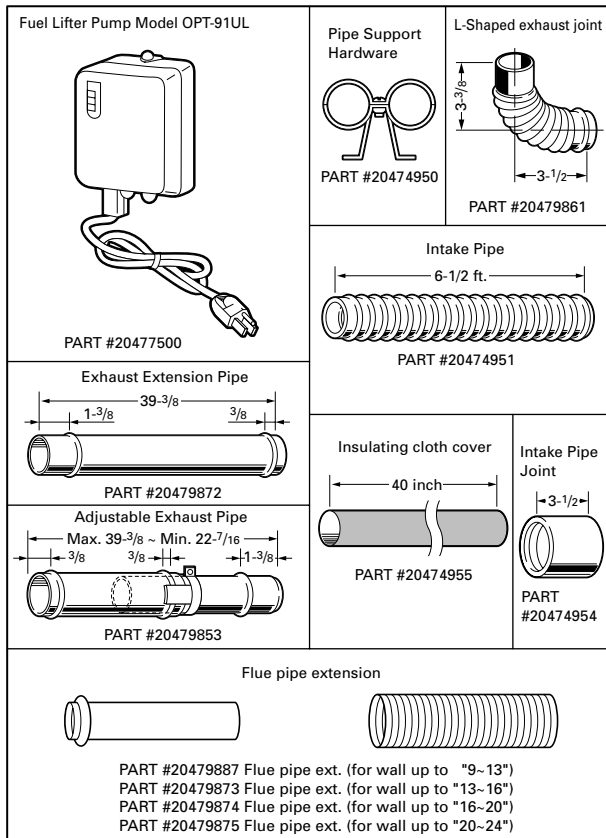

# EXTENSION KIT

### Extension Pipe Kit (L) PART #20479898

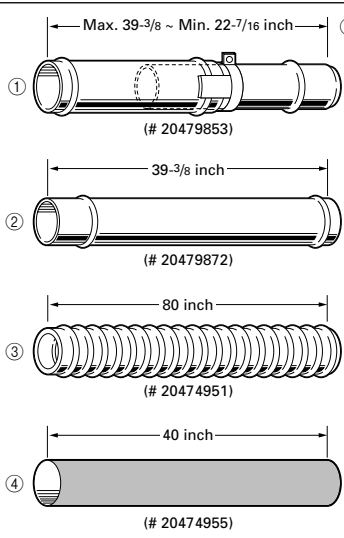

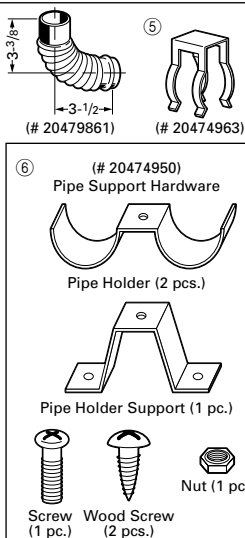

No.	Name of Part	Q'ty
①	Adjustable Exhaust Pipe Max. 39-3/8 ~ 22-7/16	1
②	Exhaust Extension Pipe (long, 39-3/8 inch)	1
③	Intake Pipe (80 inch)	1
④	Insulating cloth cover (40 inch)	2
⑤	Pipe Holder	2
⑥	Pipe Support Hardware	3 sets
⑦	L-Shaped Exhaust Joint	1

**Figure 1**

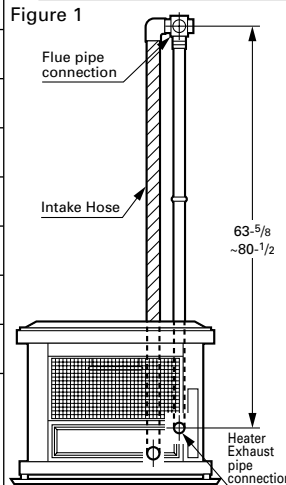

When using the "Extension pipe (L)" extension kit, the distance between the heater exhaust pipe connection and the flue pipe connection must be at least 63-5/8 inch but no more than 80-1/2 inch. (See Figure 1 for reference.)

### INSTALLATION WITH EXTENSION PIPE KIT (L)

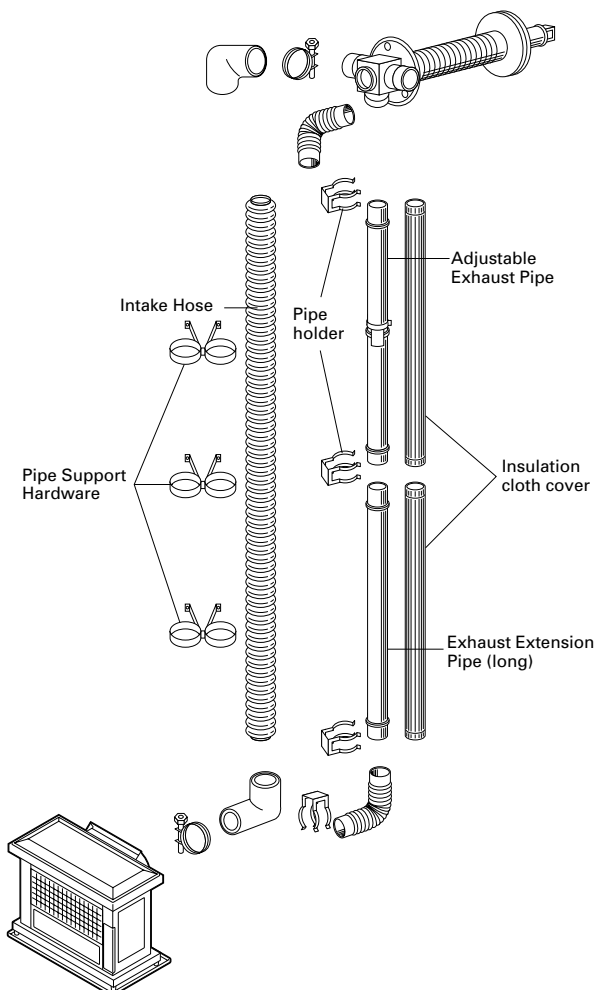

**NOTE: Use "L"-shaped Exhaust Joint if necessary.**

### Extension Pipe Kit (M) PART #20479897

No.	Name of Part	Q'ty	<b>Figure 2</b> 
①	Adjustable Exhaust Pipe Max. 39- <sup>3</sup> / <sub>8</sub> - Min. 22- <sup>7</sup> / <sub>16</sub>	1	
②	Intake Pipe (40 inch)	1	
③	Insulating cloth cover (40 inch)	1	
④	Pipe Holder	1	
⑤	Pipe Support Hardware	2 sets	
⑥	L-Shaped Exhaust Joint	1	

When using the "Extension pipe (M)" extension kit, the distance between the heater exhaust pipe connection and the flue pipe connection must be at least 25-<sup>5</sup>/<sub>8</sub> inch but no more than 42-<sup>1</sup>/<sub>2</sub> inch. (See Figure 2 for reference.)

### Extension Pipe Kit (S) PART #20479896

No.	Name of Part	Q'ty	<b>Figure 3</b> 
①	Adjustable Exhaust Pipe Max. 19- <sup>11</sup> / <sub>16</sub> - Min. 12- <sup>5</sup> / <sub>8</sub>	1	
②	Intake Pipe (20 inch)	1	
③	Insulating cloth cover (40 inch)	1	
④	Pipe Holder	1	
⑤	Pipe Support Hardware	1 sets	
⑥	L-Shaped Exhaust Joint	1	

When using the "Extension pipe (S)" extension kit, the distance between the heater exhaust pipe connection and the flue pipe connection must be at least 15-<sup>3</sup>/<sub>4</sub> inch but no more than 22-<sup>3</sup>/<sub>4</sub> inch. (See Figure 3 for reference.)

## SAFETY TIPS FOR INSTALLATION

Follow the safety tips below when planning the installation of your Laser 60AT.

1. Intake and exhaust flue pipe openings must be fully exposed to outside air. Do not vent into chimney garage, basement under the floor, or into any enclosed area.

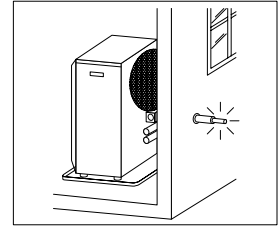

2. Do not install flue pipe in close proximity to other objects or materials (See page 23).

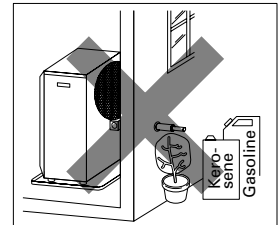

3. Before making a hole in your wall for the flue pipe, make sure the area is free of electrical wires, gas pipes and other obstacles.

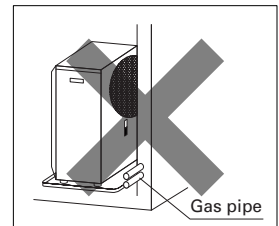

4. Do not install flue pipe where it will be exposed to heavy snow collected leaves or strong drafts.

**Important:**

In areas of heavy snow falls, ground surface clearance must be increased according to average snow falls.

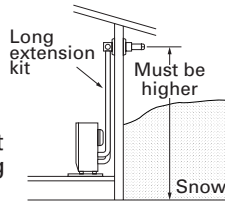

**Important:**

In open area with strong wind, a wind break may be necessary.

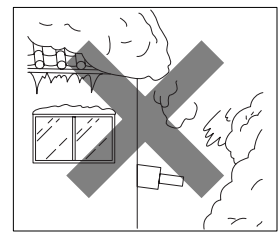
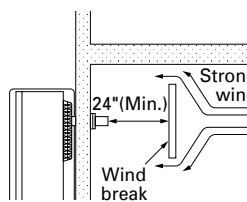

5. Do not install the flue pipe down from the heater.

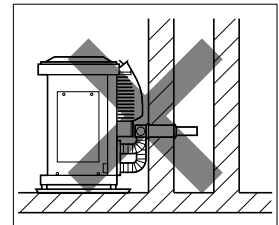
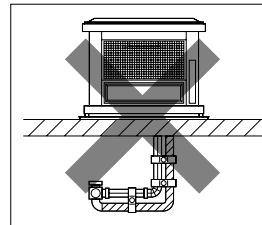
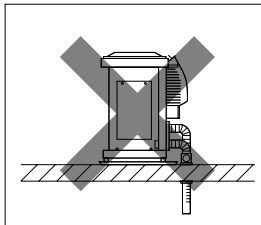

6. Total length of extension pipe between heater and flue pipe must be no greater than 10 ft. and 3 bends may be used.

NOTE: When using extension pipes always cover the exhaust pipe with the insulating cloth cover.

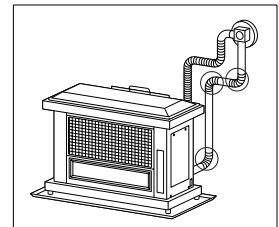

7. A B-Vent shall not be used in the vent system.

8. Installing in the mobile home, the eaves non combustible must be necessary.

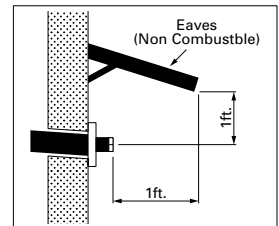

# INSTALLATION OF HEATER AND FLUE PIPE

**IMPORTANT:** Check and comply with all state and local codes that may apply to vented heaters before beginning installation.

**NOTE:** This heater is designed to be used at altitudes up to 3,000 FT. above sea level.

For use at altitudes higher than 3,000 FT. and up to 6,000 FT., adjustments to the heater must be made. Consult with your dealer.

1. Select heater location. Allow clearances as indicated below between heater and all other materials. (See Fig. 1)

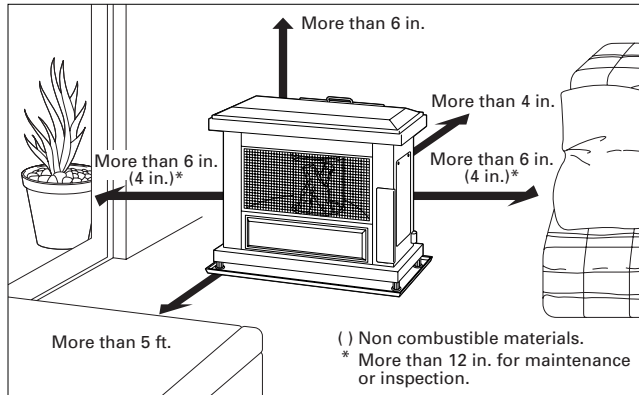

Fig. 1

2. Make sure that the outside area to where the flue pipe will reach is clear of any objects. (See Fig. 2 & 3)

**CAUTION!** The standard flue pipe installation, as shown in Fig. 2, is for wall thickness from 4 in. to 9 in. ONLY.

Note: For wall thickness more than 9 in., refer to page 18 for available flue pipe extensions.

Note: The flue pipe can be installed through any standard building materials.

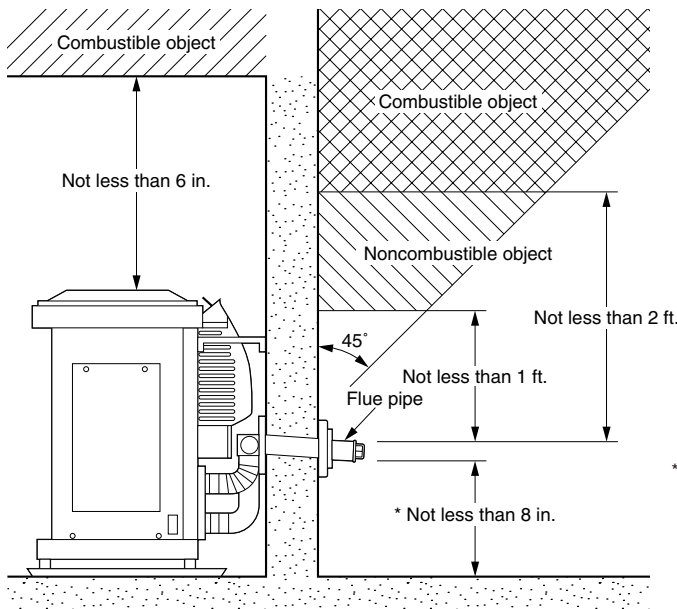

Fig. 2

<Standard Flue Pipe Installation>

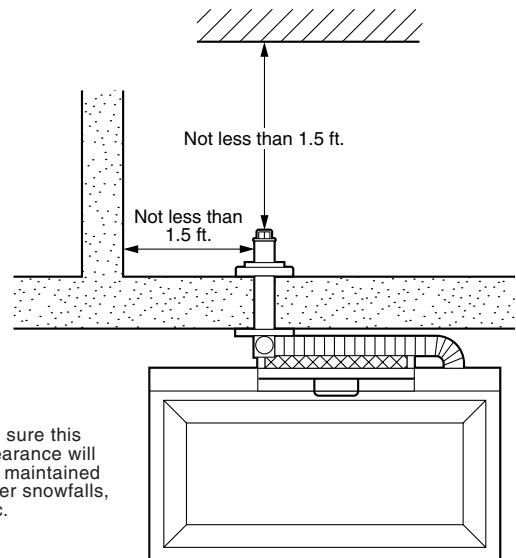
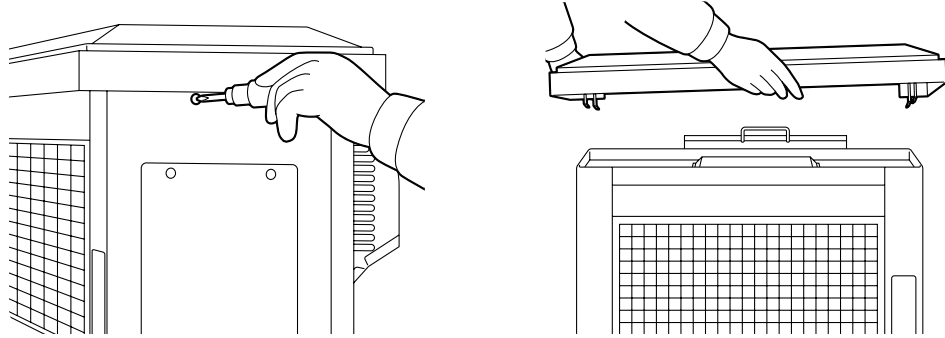

Fig. 3

3. Install the ceramic log.

a. Remove four (4) screws from top plate and remove the top plate.



b. Remove four (4) screws from canopy guard and remove the canopy guard. Remove the heat chamber lid from the heat exchanger.

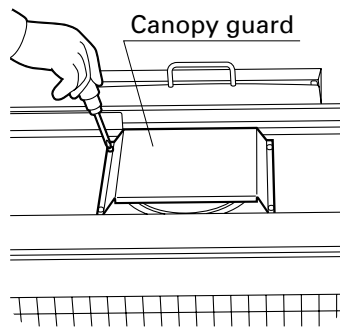

<Canopy Guard>

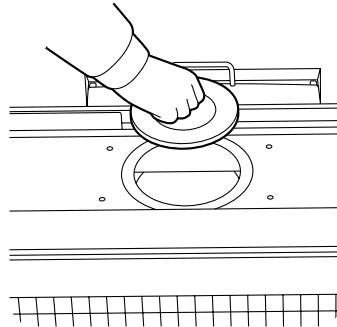

<Heat Chamber Lid>

c. Gently insert the ceramic logs into three (3) brackets inside of burner properly. After inserting the ceramic logs, install log supporter on the upper holes of the ceramic logs. Adjust the log supporter so as to place the logs at the center of the burner.

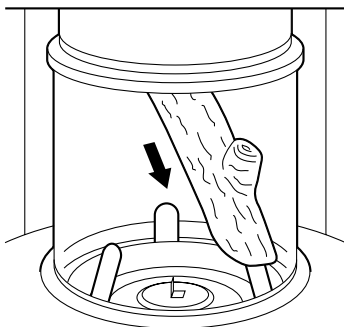

Correct

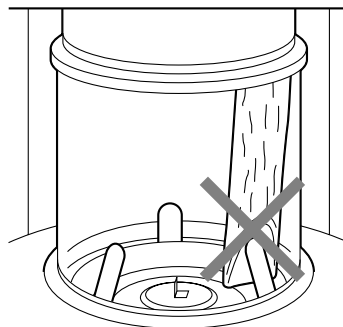

Wrong

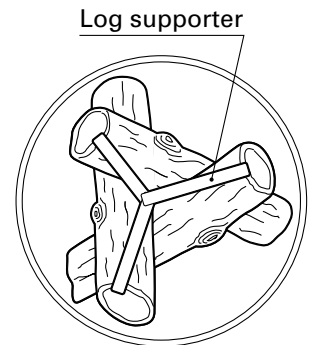

Top View



- For standard installation, use the template enclosed with the heater to position the hole for the flue pipe. Tack or tape template to the wall at the desired position (See Fig. 4).

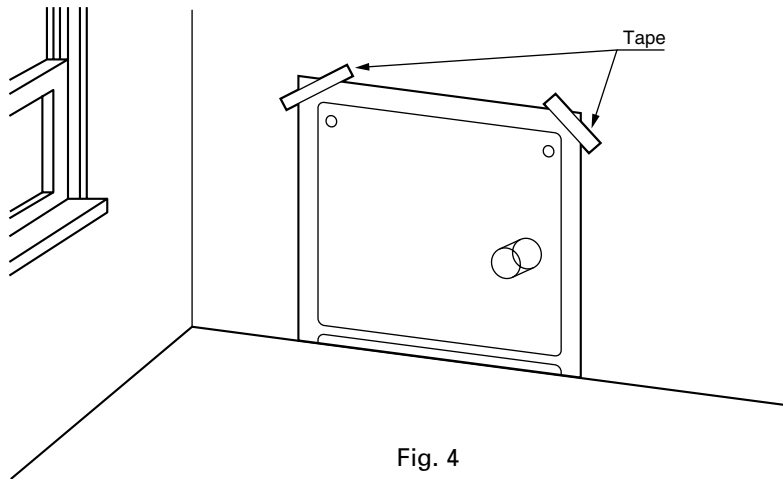

Fig. 4

NOTE: Heater should be installed on a sturdy floor that is level and flat.

NOTE: The template can be adjusted for use of non-standard installations such as the use of extension pipe kits.

- Cut the hole for the flue pipe from inside the room. Use a 2-3/4 to 3" diameter hole saw attached to an electric drill (See Fig. 5). The opening on the inside wall should be slightly higher than the outside opening (approximately 1/4") so that the flue pipe will slope slightly downward (approximately 2 degrees) after it is installed (See Fig. 6). This will enable the draining of condensed moisture from the flue pipe to the outside and prevent rain or snow entering from outside after installation.

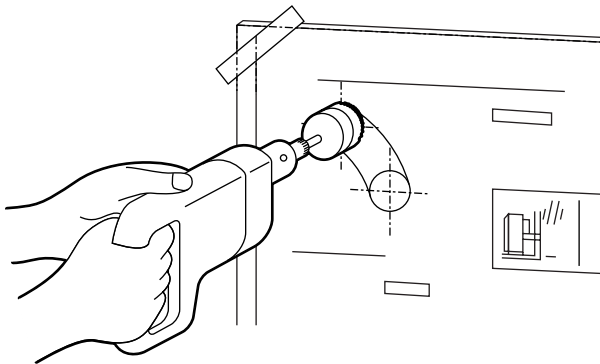

Fig. 5

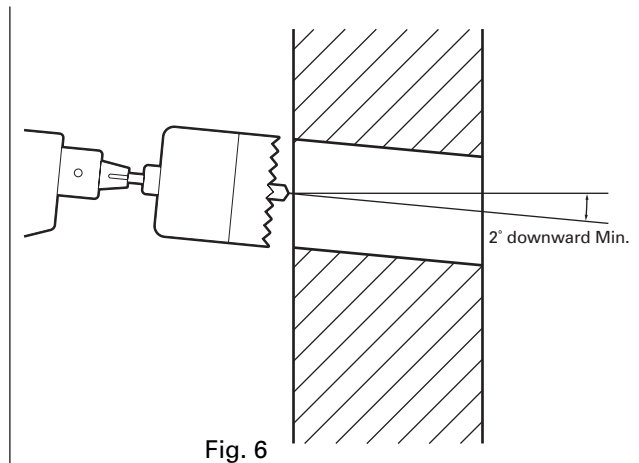

Fig. 6

NOTE: After the cutting of the hole is completed, remove the template from the wall.

6. Install the inner flue pipe.

a. For wall thickness 5-3/16" to 9"

From inside the room, insert the inner flue pipe through the hole. Make sure the arrow on the inner flue pipe is pointing up. Secure the inner flue pipe to the wall with the three wood screws. (See Fig. 7.)

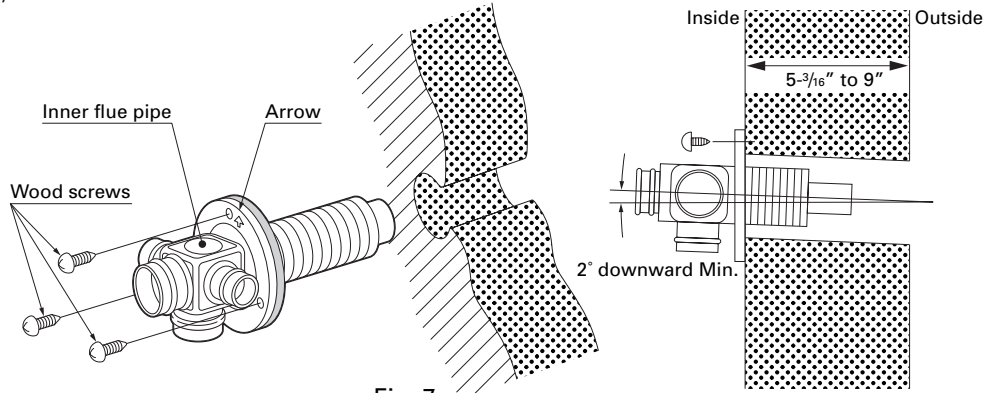

Fig. 7

b. For wall thickness 4" to 5-3/16"

In the event that the wall is too thin, use the spacer as indicated in Fig. 8.

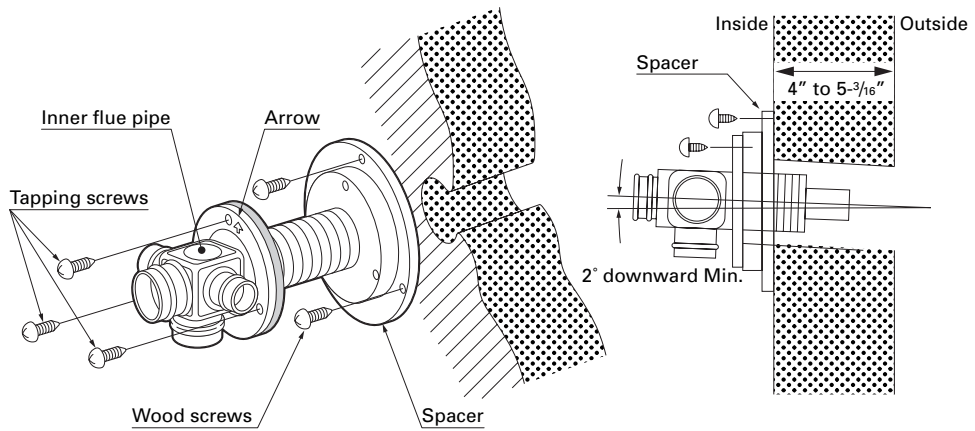

Fig. 8

c. From outside, insert the outer flue pipe through the hole. Secure the outer flue pipe to the wall by turning it clockwise. This locks the two halves together (See fig. 9).

**IMPORTANT:** Make sure the arrow on the outer flue pipe flange is pointing up. Make sure to secure the outer flue pipe well. (A-part shown in Fig. 9)

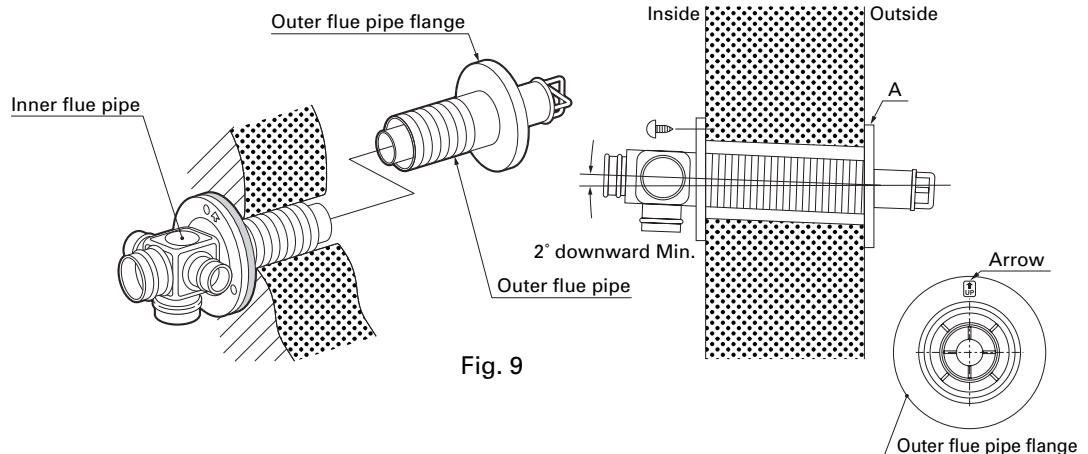

Fig. 9

7. Insert the bent joint to the exhaust opening of the flue pipe. Cut the inlet hose for desired length if necessary. Attach the L-shaped hose to each end of the inlet hose and attach the L-shaped hose to the intake opening of the flue pipe. Secure the L-shaped hose to the intake opening with the hose band. Plug the unused exhaust and intake opening with the caps provided with the heater. Make sure the caps fit tightly onto the opening (See Fig. 10).

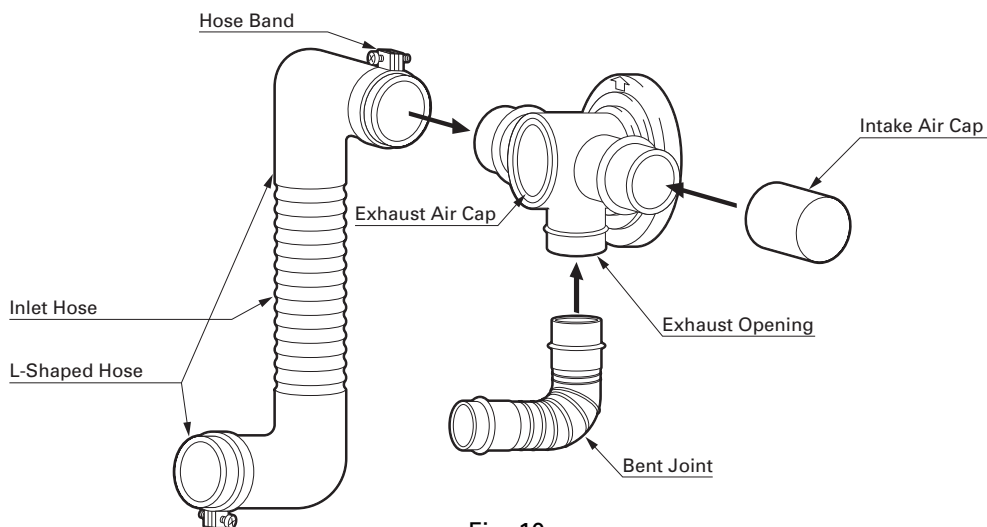

Fig. 10

NOTE: If the inlet hose is not smoothly inserted into the L-shaped hose, apply water or soap suds to the inlet hose.

8. Move the heater into position. Connect the bent joint to the exhaust outlet opening (upper opening) and attach the L-shaped hose to the intake inlet opening. Make sure all connections are tight (See Fig. 11).

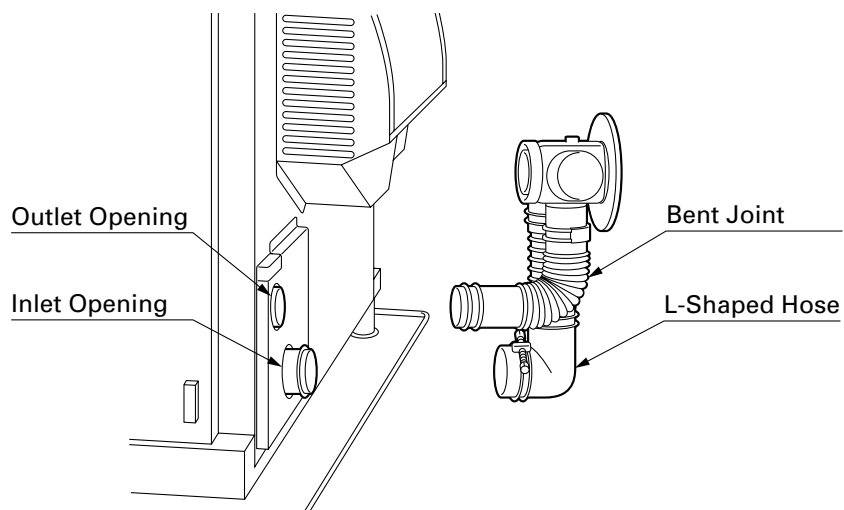

Fig. 11

- Secure the L-shaped hose to the intake inlet opening with the hose band. Secure the bent joint to the flue pipe with the pipe holder (If the extension pipe is used, also attach the pipe holder to the connection of the bent joint and the extension pipe). Secure the bent joint (or the extension pipe) to the exhaust outlet opening by sliding the pipe stopper in the exhaust opening bracket (See Fig. 12).

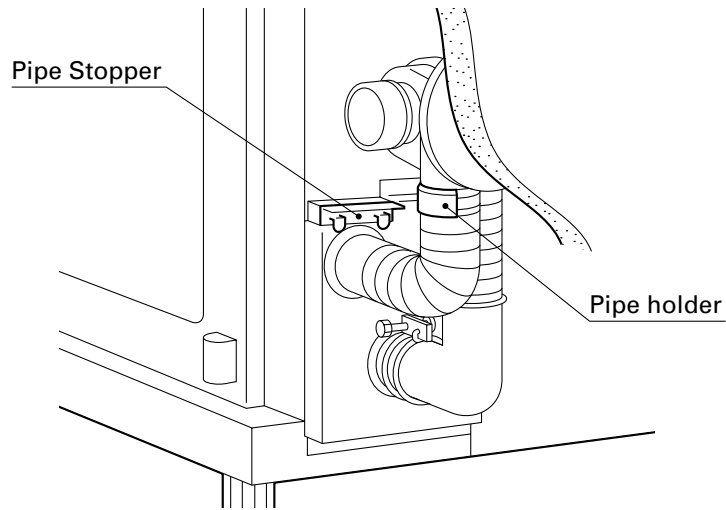
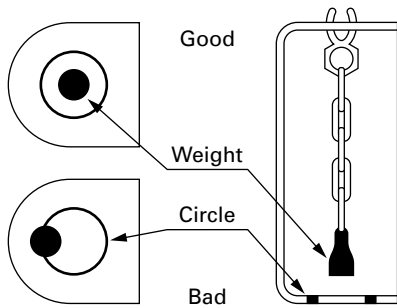

Fig. 12

- Make sure the position of the heater is level by using the plumb bob located at the right side of the heater. The plumb bob weight should be within the circle. If the plumb bob weight is not within the circle, adjust the heater legs until the plumb bob weight is within the red circle (See Fig. 13 & 14).



Plumb bob as viewed from above

Fig. 13

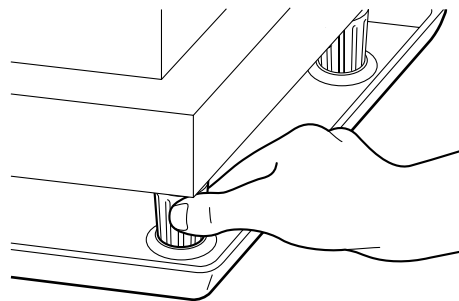

Fig. 14

11. A room temperature sensor is provided with an eight (8) feet long extension wire. It is located on the rear of the cabinet. Make sure that the extension wire is not touching the exhaust pipe. The room temperature sensor can be installed either with the self adhesive tape on the back or with a wood screw provided with the sensor depending on the type of surface chosen for installation.

NOTE: Choose a location for the sensor that is not in the path of direct sunlight, drafts or the flow of warm air from the heater.

(a) Self Adhesive Tape

Peel off the protective tape on the back of the sensor and expose the adhesives. Place the sensor on the desired location on the wall and press down.

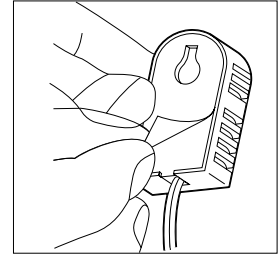

(b) Wood Screw

Screw down the wood screw provided with the heater into the desired location on the wall. Hook the back of the room temperature sensor.

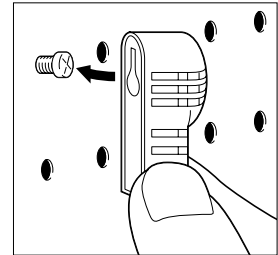

12. After installation is completed, secure heater to the wall with the wall brackets provided with the heater. Make sure the heater is parallel to the wall (See Fig. 15).

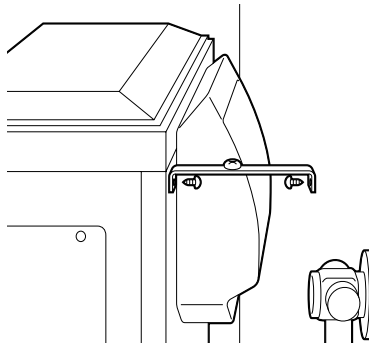

Fig. 15

13. Before ignition, recheck the following:
- All connections are tight and firm.
  - The heater and the flue pipe areas are free of any materials.
  - The heater is level and parallel to the wall.

# SECTION J: FUELING

WARNING: Use only ASTM D3699 1-K kerosene, ASTM D396 Low Sulfur No.1 Fuel Oil, or ASTM D975 Ultra Low Sulfur Diesel (ULSD). NEVER USE GASOLINE. Use of gasoline can lead to uncontrollable flames resulting in destructive fire.

## Laser 60AT FUEL SYSTEM OPTIONS

- **Large Capacity External Tank**

Tank must be purchased separately and installed by a qualified fuel supply technician.

### EXTERNAL TANK INSTALLATION

NOTE: External tank installation must comply with National Fire Protection Association Code NFPA 31, CSA Standard B139, the Installation Code for Oil Burning Equipment, or locally applicable codes. Check with local building officials.

The following instructions should be followed for installation of a large capacity, gravity-fed external fuel tank.

- Installation height of tank's fuel outlet should be at least 16 in. above floor surface upon which heater rests.
- To avoid excess fuel pressure to heater, top of fuel tank should be no more than 8-1/2 ft. above floor surface upon which heater rests.
- Fuel tank should be located at least 6 ft. away from all heat sources.
- 3/8" OD copper tubing should be used for fuel line.
- To prevent air locks in fuel line, fuel line should be smooth with no U-shaped or sharp bends.
- Install a UL listed fuel filter at the fuel tank outlet (**it is highly recommended to use an in-line small mesh size filter with water block, e.g. 10 micro filter**). Shut-off valves should also be installed on the fuel line and connected the tank as illustrated on page 30.

NOTE: An additional shut-off valve installed next to the exterior wall will minimize fuel to be drained should heater have to be disconnected. If the valve is on interior side, a fusible link type is recommended.

1. Be sure all external tanks have an operating vent.
2. Be sure to observe the maximum and minimum tank heights as specified.

NOTE: If the maximum height from the top of the fuel tank to the bottom of the heater exceeds 8-1/2 ft., a fuel pressure reducing valve, preset at 2.5 psi, is required. Pressure Reducing Valve Part#10005099 has 3/8 in. (N.P.T.) inlet and outlet female openings to accept the fuel line fittings.

NOTE: Fusible Link Valve (#10005597)

- It is most important that the valve, depending on its use, be fully opened or fully closed.
- The top nut on the valve (below the turn handle) is sealed and should never be tightened or removed.
- When installing fuel lines to the valve, be sure to check for fuel leakage.
- A LEAKING VALVE MUST ALWAYS BE REPLACED.

NOTE: The fusible link valve is in the open position when the valve stem appears above the center of the turn handle as shown in the illustration.



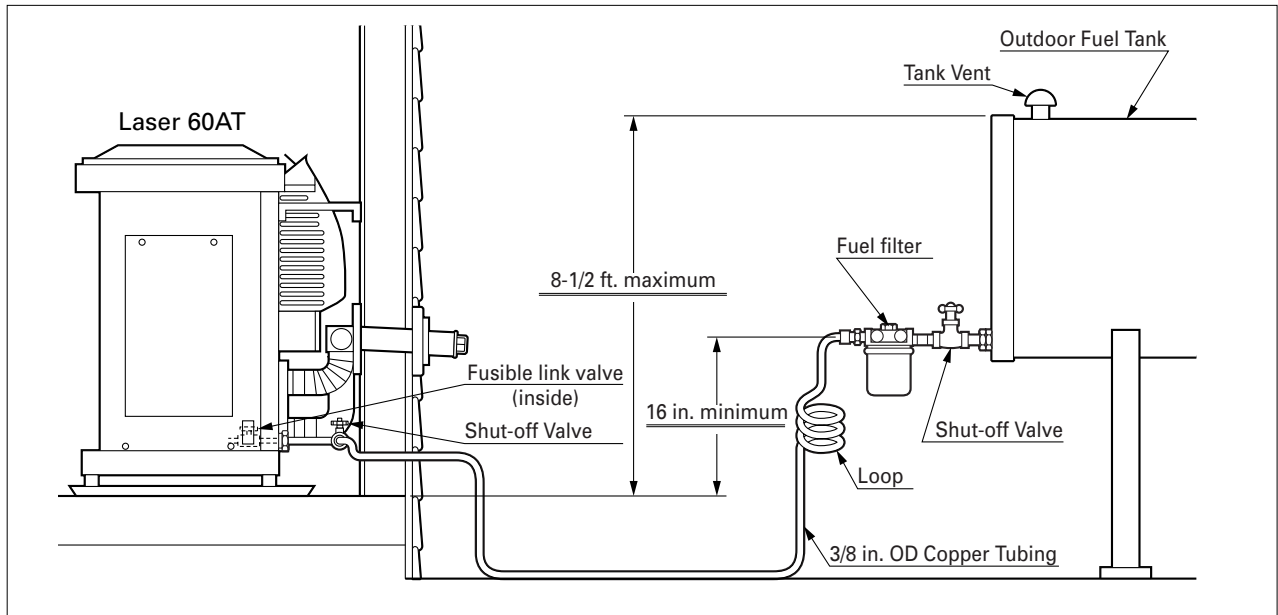

# LIMITED WARRANTY

TOYOTOMI U.S.A., INC. ("TOYOTOMI") warrants each product and any parts thereof sold by it to be free from defects in materials or workmanship under normal use and service for TWELVE (12) MONTHS\* from the date of delivery to the original purchaser at retail subject to the following terms and conditions :

**WHAT IS COVERED :** Product or any parts thereof which are defective in materials or workmanship.

**WHAT IS NOT COVERED :**

(1) This warranty does not extend to any defect due to the negligence of others: failure to install, operate, or maintain unit in accordance with instructions (Installation and Operation instructions are furnished with each new unit); unreasonable use; accidents; alteration, use of unauthorized or non-standardized TOYOTOMI parts and accessories; electrical malfunction, i.e., as resulting from large power surges, short circuit, etc.; incorrect installation; use of any fuel other than that specified in owner's manuals; or repair by anyone other than a service facility specified by TOYOTOMI.

(2) Normal wear and tear of parts, including hoses, wires, burner mats, fuel nozzles, filters and accessories.

(3) This warranty does not cover shipping costs.

**WHO IS COVERED :** The original purchaser at retail.

**WHAT WE WILL DO :** TOYOTOMI will either repair or replace, at its option, all defective parts free of charge that are covered by this limited warranty on a carry-in basis, to your nearest authorized dealer or distributor of TOYOTOMI.

**WHAT YOU MUST DO FOR WARRANTY SERVICE :** You must return the defective Product or part to any authorized dealer or distributor of TOYOTOMI with this LIMITED WARRANTY and a copy of your bill of sale or credit card charge receipt or other documents evidencing the date of the Product's delivery, if service is not available locally, please contact our CUSTOMER RELATIONS DEPARTMENT at :

TOYOTOMI U.S.A., INC.  
604 Federal Road, Brookfield, CT 06804  
(203)775-1909

THE FOREGOING EXPRESSES ALL OF TOYOTOMI'S OBLIGATIONS AND LIABILITIES WITH RESPECT TO THE QUALITY OF PRODUCT FURNISHED BY IT. ALL OTHER WARRANTIES, EXPRESSED OR IMPLIED, INCLUDING THE WARRANTIES OF MERCHANTABILITY OR FITNESS FOR A PARTICULAR PURPOSE ARE DISCLAIMED. TOYOTOMI SHALL NOT BE LIABLE FOR THE LOSS OF USE OF THE PRODUCT, INCONVENIENCE, LOSS OR ANY OTHER DAMAGES, DIRECT OR CONSEQUENTIAL ARISING OUT OF, THE USE OF, OR INABILITY TO USE, THE PRODUCT OR DAMAGES RESULTING FROM OR ATTRIBUTABLE TO DEFECTS IN THE PRODUCT.

No one other than TOYOTOMI has authority to extend or modify the terms of this Limited Warranty in any manner whatsoever.

Some states or provinces do not allow the exclusion or limitation of incidental or consequential damages or limitations on how long an implied warranty lasts, so these limitations or exclusions may not apply to you. This Limited Warranty gives you specific legal rights and you may also have other rights that vary from state to state, or province to province.

\* In addition to the warranty period stated above, an extended two (2) year warranty (3 years from date of purchase) is on for the following parts. :

1. Vented Heater :
  - A. Burner Pot
  - B. Heat Chamber (Excluding Glass Cylinder)
  - C. Heat Exchanger
2. Hot Water Heater :
  - A. Burner Top
  - B. Heat Exchanger

**NOTE :** THE EXTENDED WARRANTY POLICY IS APPLICABLE ONLY FOR THE REPLACEMENT OF THE ORIGINAL FACTORY-INSTALLED PARTS THAT HAVE FAILED WITHIN THE TIME LIMITATIONS AS INDICATED. REPLACEMENT PARTS ARE WARRANTED FOR THE REMAINDER OF THE ORIGINAL PART WARRANTY PERIOD. LABOR IS NOT COVERED ON THE EXTENDED WARRANTY.

7104002060



**TOYOTOMI U.S.A., INC.**

604 Federal Road, Brookfield, CT 06804  
www.toyotomiusa.com

Rev. 6/14

Part #20479994

Printed in Japan