

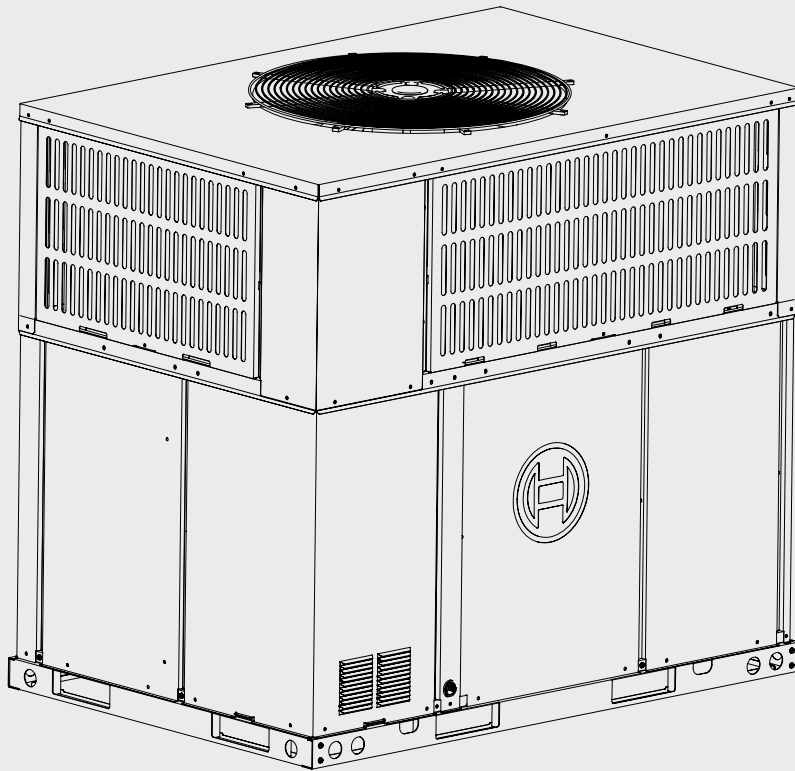

Installation and Operating Instructions

Bosch IDP Heat Pump Premium Series Packaged Unit

18 SEER2 | 3 & 5 Ton Capacity | R454B



BTC 762003316 D / 02.2026



Table of Contents

1	Key to Symbols and Safety Instructions	4	14	System Operation and Troubleshooting	38
1.1	Key to Symbols	4	14.1	Control Logic Description	38
1.2	Explanation of Symbols Displayed on the Unit	4	14.2	Sensors (Thermistors/Pressure Transducer)	38
1.3	Safety	4	14.3	Defrost Description	39
<hr/>			14.4	Compressor Crankcase Heater Description	39
2	Component Location	10	14.5	Reversing Valve Operation	39
2.1	3 Ton Model	10	14.6	A2L Refrigerant Sensor	40
2.2	5 Ton Model	11	14.7	Protection Functions	41
<hr/>			14.8	Fault Code Table	42
3	Dimensions	12	14.9	System Protection Status Codes	43
3.1	3 Ton Model	12	14.10	Parameter Point Check Table	44
3.1.1	Unit Dimensions	12	14.11	Control Board Overviews	45
3.1.2	Dimensions - Back and Bottom	13	14.12	Error Code Troubleshooting	48
3.1.3	Dimensions - Left and Top	14	14.12.1	LED Flashing Troubleshooting (IDU)	62
3.2	5 Ton Model	15	14.12.2	Online Help Resources	64
3.2.1	Unit Dimensions	15	14.13	Temperature and Resistance Relationship Tables (for Sensors)	65
3.2.2	Dimensions - Back and Bottom	16	14.14	Temperature and Resistance Relationship Tables (for T5 Sensor)	66
3.2.3	Dimensions - Right and Top	17	<hr/>		
<hr/>			15	Wiring Diagram	67
4	Bosch IDS Gateway Accessory and EasyAir Mobile App	18	<hr/>		
5	Installation	19	16	Care and Maintenance	68
5.1	Pre-Installation	19	16.1	Cleaning Precautions	68
5.2	Rigging and Lifting	19	16.2	Regular Maintenance	68
5.3	Location Restrictions	19	<hr/>		
5.4	Refrigerant Charge and Room Area Limitations	21	17	Disposal	68
5.4.1	The Room Area Calculation Requirements	21	<hr/>		
5.4.2	The Allowed Maximum Refrigerant Charge and Required Minimum Room Area	23	18	Care and Maintenance	68
5.5	Rooftop Installation - Curb Mounting	26	18.1	Cleaning Precautions	68
<hr/>			18.2	Regular Maintenance	68
6	Airflow Performance	27	<hr/>		
7	Indoor Fan Motor Function	28	19	Disposal	69
8	Ductwork	29	<hr/>		
9	Condensate Drain Connection	30	<hr/>		
9.1	Install Drain Pipe	30	<hr/>		
10	Air Filter (Not Factory-Installed)	30	<hr/>		
11	Electrical Wiring	31	<hr/>		
11.1	Power Wiring	31	<hr/>		
11.2	Grounding	31	<hr/>		
11.3	Control Wiring	31	<hr/>		
12	Start Up	34	<hr/>		
12.1	System Start Up	34	<hr/>		
12.2	Communication with BCC100/BCC110 (Recommended)	35	<hr/>		
13	System Charge Adjustment	36	<hr/>		
13.1	Charging: Weigh-In Method (Recommended)	36	<hr/>		
13.2	Subcooling Charging And Refrigerant Adjustment In Cooling (Above 55°F Outdoor Temp.)	36	<hr/>		

1 Key to Symbols and Safety Instructions

1.1 Key to Symbols

Warnings

In warnings, signal words at the beginning of a warning are used to indicate the type and seriousness of the ensuing risk if measures for minimizing danger are not taken.

The following keywords are defined and can be used in this document:

DANGER
DANGER indicates a hazardous situation which, if not avoided, will result in death or serious injury.

WARNING
WARNING indicates a hazardous situation which, if not avoided, could result in death or serious injury.

CAUTION
CAUTION indicates a hazardous situation which, if not avoided, could result in minor to moderate injury.

NOTICE
NOTICE is used to address practices not related to personal injury.

Important information

The info symbol indicates important information where there is no risk to people or property.

1.2 Explanation of Symbols Displayed on the Unit

Symbol	
	WARNING This symbol shows that this appliance uses a mildly flammable refrigerant. If the refrigerant is leaked and exposed to an external ignition source, there is a risk of fire.
	WARNING This symbol shows that appliance shall be installed, operated and stored in a room with a floor area not less than the minimum room area.
	CAUTION This symbol shows that the operation manual should be read carefully.
	CAUTION This symbol shows that a service personnel should be handling this equipment with reference to the installation manual.
	CAUTION This symbol shows that information is available such as the operating manual or installation manual.
	CAUTION This symbol shows that when addition of charge is required by the manufacturer installation instructions for completing the REFRIGERATING SYSTEM. Recorded the resulting total REFRIGERANT CHARGE for each REFRIGERATING SYSTEM.

Table 1

1.3 Safety

Please read safety precautions before installation

WARNING

Electrical hazard 380 Volts DC!

Failure to follow this warning could result in property damage, severe personal injury, or death.

WAIT FIVE (5) MINUTES after disconnecting power prior to touching electrical components as they may hold a dangerous charge of 380 VDC, then verify DC Voltage is less than 42VDC at inverter TEST POINTS P-N.

This document is customer property and is to remain with this unit. Please return to service information pack upon completion of work.

These instructions do not cover all variations in systems or provide for every possible contingency to be met in connection with the installation.

Should further information be desired or should particular problems arise which are not covered sufficiently for the purchaser's purposes, the matter should be referred to your installing dealer or local distributor.



The manufacturer recommends installing only approved matched indoor and outdoor systems. The approved matchups are AHRI rated and indoor units must be equipped with R454B TXV. Some of the benefits of installing approved matched indoor and outdoor split systems are maximum efficiency, optimum performance and the best overall system reliability.



This document contains a wiring diagram and service information. This is customer property and is to remain with this unit. Please return to service information pack upon completion of work. installation.



WARNING

Personal injury, product damage!

This information is intended for use by individuals possessing adequate backgrounds of electrical and mechanical experience. Any attempt to repair a central air conditioning product may result in personal injury and/or property damage.



WARNING

Hazardous voltage!

Failure to follow this warning could result in property damage, severe personal injury, or death.

Disconnect all electric power, including remote disconnects before servicing. Follow proper lockout/tagout procedures to ensure the power cannot be inadvertently energized.



WARNING

Refrigerant oil!

Any attempt to repair a central air conditioning product may result in property damage, severe personal injury, or death. These units use R454b refrigerant. Use only R454b approved service equipment. All R454b systems with variable speed compressors use a POE oil (VG75 or equivalent) that readily absorbs moisture from the atmosphere. To limit this 'hygroscopic' action, the system should remain sealed whenever possible. If a system has been open to the atmosphere for more than 4 hours, the compressor oil must be replaced. Never break a vacuum with air and always change the driers when opening the system for component replacement.



WARNING

Hot surface!

May cause minor to severe burning. Failure to follow this Caution could result in property damage or personal injury.

Do not touch high temperature components such as the compressor.



WARNING

Contains flammable refrigerant!

Failure to follow proper procedures can result in personal illness or injury or severe equipment damage. System contains oil and refrigerant under high pressure. Recover refrigerant to relieve pressure before opening system. Flammable refrigerant used.



WARNING

Contains lead!

This product can expose you to chemicals including Lead and Lead components, which are known to the State of California to cause cancer and birth defects or other reproductive harm. For more information go to www.P65Warnings.ca.gov.



CAUTION

Grounding required!

Failure to inspect or use proper service tools may result in equipment damage or personal injury. Reconnect all grounding devices. All parts of this product that are capable of conducting electrical current are grounded. If grounding wires, screws, straps, clips, nuts, or washers used to complete a path to ground are removed for service, they must be returned to their original position and properly fastened.



WARNING

Service valves!

Failure to follow this warning will result in abrupt release of system charge and may result in personal injury and/ or property damage. Extreme caution should be exercised when opening the Liquid Line Service valve. Turn valve stem counterclockwise only until the stem contacts the rolled edge.



WARNING

Brazing or crimping required!

Failure to inspect lines or use proper service tools may result in equipment damage or personal injury. If using existing refrigerant lines, make certain that all joints are re-crimped or brazed, not soldered.

If refrigerant gas leaks during installation, ventilate the area immediately.

Comply with national gas regulations.



WARNING

High current leakage!

Grounding is required before connecting electrical supply. Failure to follow this warning could result in property damage, severe personal injury, or death.



WARNING

Risk of fire!

Mildly flammable refrigerant used.

Follow handling instructions carefully in compliance with national and local regulations.



DANGER

Fire, explosion!

Store in a well ventilated room without continuously operating flames or other potential ignition.



WARNING

Risk of electric shock!

Can cause injury or death. Disconnect all remote electric power supplies before servicing.

 **WARNING**
Risk of fire!

Flammable refrigerant used. To be repaired only by trained service personnel. Do not puncture refrigerant tubing.

Dispose of properly in accordance with federal or local regulations. Flammable refrigerant used.

Flammable refrigerant used. Consult repair manual/owner's guide before attempting to service this product. All safety precautions must be followed.

Auxiliary devices which may be ignition sources shall not be installed in the ductwork, other than auxiliary devices listed for use with the specific appliance. See instructions.

 **WARNING**
Personal injury!

This appliance is not intended for use by persons (including children) with reduced physical, sensory or mental capabilities, or persons who lack experience and knowledge, unless they are supervised or have been given instructions concerning the use of the appliance by a person responsible for their safety.

Children should be supervised to ensure that they do not play with the appliance.

Any person who is involved with working on or opening a refrigerant circuit should hold a current valid certificate from an industry-accredited assessment authority, which authorizes their competence to handle refrigerants safely in accordance with an industry recognized assessment credential.

Servicing shall only be performed as recommended by the equipment manufacturer.

Maintenance and repair requiring the assistance of other skilled personnel shall be carried out under the supervision of a person competent in the use of flammable refrigerants.

Prior to beginning work on systems containing flammable refrigerants, safety checks are necessary to minimize the risk of ignition.

 **WARNING**
Flammable refrigerant!

Do not use means to accelerate the defrosting process or to clean, other than those recommended by the manufacturer.

The appliance shall be stored in a room that does not have continuously operating ignition sources (for example: open flames, an operating gas appliance or an operating electric heater).

Do not pierce or burn the unit.

Be aware that refrigerants may not contain an odour.

 **WARNING**
Safe handling of flammable refrigerant!

Be sure the heat pump is grounded. In order to avoid electric shock, make sure that the unit is grounded and that the earth wire is not connected to a gas or water pipe, lightning conductor or telephone earth wire.

Do not operate the heat pump with wet hands. An electric shock may happen.

Do not operate the heat pump when using a room fumigation such as insecticide. Failure to observe this precaution could cause the chemicals to become deposited in the unit, which could endanger the health of those who are hypersensitive to chemicals.

To avoid oxygen deficiency, ventilate the room sufficiently if equipment with a burner is used together with the heat pump.

Arrange the drain hose to ensure smooth drainage. Incomplete drainage may cause wetting of the building, furniture, etc.

Never touch the internal parts of the controller. Do not remove the front panel. Some parts inside are dangerous to touch, and machine troubles may occur.

Attention is drawn to the fact that additional transportation regulations may exist with respect to equipment containing flammable gas. The maximum number of pieces of equipment or the configuration of the equipment permitted to be transported together will be determined by the applicable transport regulations.

Signs for similar appliances used in a work area are generally addressed by local regulations and give the minimum requirements for the provision of safety and/or health signs for a work location.

Storage package protection should be constructed such a way that mechanical damage to the equipment inside the package will not cause a leak of the REFRIGERANT CHARGE.

The maximum number of pieces of equipment permitted to be stored together will be determined by local regulations.

Do not place appliances which produce open flame in places exposed to the air flow from the unit or under the indoor unit. It may cause incomplete combustion or deformation of the unit due to the heat.

Do not install the heat pump in a location where flammable gas may leak out. If the gas leaks out and stays around the air conditioner, a fire may break out.

 **WARNING**
Flammable refrigerant!

The appliance uses R454B refrigerant.

**NOTICE****Indoor unit required!**

The indoor units must be matched with R-454B TXV. The model of R-454B TXV can be changed according to the system capacity.

WARNING
Personal Injury, flammable refrigerant!

When repairing the refrigerating system, comply with the following precautions prior to conducting work on the system:

- Work shall be undertaken according to controlled procedures to minimize the risk of the presence of flammable gases or vapors while the work is being performed.
- All maintenance staff and others working in the local area shall be instructed on the nature of work being carried out. Work in confined spaces shall be avoided.
- The area shall be checked with an appropriate refrigerant detector prior to and during work, to ensure the technician is aware of potentially toxic or flammable environment. Ensure that the leak detection equipment being used is suitable for use with all applicable refrigerants, i.e., non-sparking, adequately sealed or intrinsically safe.
- If any hot work is to be conducted on the refrigerating equipment or any associated parts, appropriate fire extinguishing equipment shall be available and easily accessible. Have a dry powder or CO2 fire extinguisher adjacent to the charging area.
- When carrying out work in relation to a refrigerating system that involves exposing any pipe work, no sources of ignition shall be used in such a manner that it may lead to the risk of fire or explosion. All possible ignition sources, including cigarette smoking, should be kept sufficiently far away from the site of installation, repair, or removal and disposal of the unit, during which refrigerant can possibly be released into the surrounding space. Prior to beginning work, the area around the equipment is to be surveyed to make sure that there are no flammable hazards or ignition risks. "No Smoking" signs shall be clearly displayed.

WARNING
Personal Injury, flammable refrigerant!

Ensure that the area is in the open or that it is adequately ventilated before opening the system or conducting any hot work. A degree of ventilation shall continue during the period that the work is carried out. The ventilation should safely disperse any released refrigerant and preferably expel it externally into the surroundings.

Where electrical components are being changed, they shall be fit according to their purpose and to the correct specification. At all times the manufacturer's maintenance and service guidelines shall be followed. If in doubt, consult the manufacturer's technical department for assistance. The following checks shall be applied to installations using flammable refrigerants:

- The actual refrigerant charge is in accordance with the room size within which the refrigerant containing parts are installed.
- The ventilation machinery and outlets are operating adequately and are not obstructed.
- If an indirect refrigerating circuit is being used, the secondary circuit shall be checked for the presence of refrigerant.
- Equipment marking must remain visible and legible. Markings and signs that are illegible shall be corrected.

WARNING
Personal Injury, flammable refrigerant!

Refrigerating pipe or components are installed in a position where they are unlikely to be exposed to any substances which may corrode refrigerant containing components, unless the components are constructed of materials that are inherently resistant to corrosion or are suitably protected against corrosion.

Repair and maintenance of electrical components shall include initial safety checks and component inspection procedures. If a fault exists that could compromise safety, then no electrical supply shall be connected to the circuit until the fault has been dealt with.

- That capacitors are discharged: this shall be done in a safe manner to avoid the possibility of sparking.
- That no live electrical components and wiring are exposed while charging, recovering or purging the system.
- That there is continuity of grounding.

WARNING
Flammable refrigerant!

Sealed electrical components shall be replaced.

Intrinsically safe components must be replaced.

Check that cabling will not be subject to wear, corrosion, excessive pressure, vibration, sharp edges or any other adverse environmental effects. The check shall also take into account the effects of aging or continual vibration from sources such as compressors or fans.

Under no circumstances shall potential sources of ignition be used while searching for or detection of refrigerant leaks. A halide torch (or any other detector using a naked flame) shall not be used.

Electronic leak detectors may be used to detect refrigerant leaks but, in the case of flammable refrigerants, the sensitivity may not be adequate, or may need re-calibration. (Detection equipment shall be calibrated in a refrigerant-free area.) Ensure that the detector is not a potential source of ignition and is suitable for the refrigerant used. Leak detection equipment shall be set at a percentage of the LFL of the refrigerant and shall be calibrated for the refrigerant employed, and the appropriate percentage of gas (25 % maximum) is confirmed.

If a leak is suspected, all naked flames shall be removed/extinguished.

If refrigerant leakage is found, brazing or crimping is required, and all refrigerants should be recovered from the system or isolated from the leakage point.

Leak detection fluids are also suitable for use with most refrigerants but the use of detergents containing chlorine shall be avoided as the chlorine may react with the refrigerant and corrode the copper pipe-work.

Examples of leak detection fluids are:

- bubble method,
- fluorescent method agents.

 **WARNING**
Flammable refrigerant!

When breaking into the refrigerant circuit to make repairs or for any other purpose conventional procedures shall be used. However, for flammable refrigerants it is important that best practice be followed, since flammability is a consideration. The following procedure shall be adhered to:

- safely remove refrigerant following local and national regulations.
- evacuate.
- purge the circuit with inert gas.
- continuously flush or purge with inert gas when using flame to open circuit, and.
- open the circuit.

The refrigerant charge shall be recovered into the correct recovery cylinders if venting is not allowed by local and national codes. For appliances containing flammable refrigerants, the system shall be purged with oxygen-free nitrogen to render the appliance safe for flammable refrigerants. This process might need to be repeated several times. Compressed air or oxygen shall not be used for purging refrigerant systems.

For appliances containing flammable refrigerants, refrigerants purging shall be achieved by breaking the vacuum in the system with oxygen-free nitrogen and continuing to fill until the working pressure is achieved, then venting to atmosphere, and finally pulling down to a vacuum. This process shall be repeated until no refrigerant is within the system. When the final oxygen-free nitrogen charge is used, the system shall be vented down to atmospheric pressure to enable work to take place.

The outlet for the vacuum pump shall not be close to any potential ignition sources, and ventilation shall be available.

Ensure that contamination of different refrigerants does not occur when using charging equipment. Hoses or lines shall be as short as possible to minimize the amount of refrigerant they contain.

Cylinders shall be kept upright. Ensure that the refrigeration system is grounded prior to charging the system with refrigerant.

If not already labeled, label the system when charging is complete.

Take extreme care not to overfill the refrigeration system.

 **WARNING**
Flammable refrigerant!

Prior to recharging the system, it shall be pressure-tested with the appropriate purging gas. The system shall be leak-tested on completion of charging but prior to commissioning. A follow up leak test shall be carried out prior to leaving the site.

Before carrying out this procedure, it is essential that the technician is completely familiar with the equipment and all its detail. It is recommended that all refrigerants are recovered safely. Prior to the task being carried out, an oil and refrigerant sample shall be taken in case analysis is required prior to re-use of reclaimed refrigerant. It is essential that electrical power is available before the task is commenced.

- a. Become familiar with the equipment and its operation.
- b. Isolate system electrically.
- c. Before attempting the procedure ensure that:
 - mechanical handling equipment is available, if required, for handling refrigerant cylinders.
 - all personal protective equipment is available and being used correctly.
 - the recovery process is supervised at all times by a competent person.
 - recovery equipment and cylinders conform to the appropriate standards.
- d. Pump down refrigerant system, if possible.
- e. If vacuuming is not possible, make an opening so that refrigerant can be removed from various parts of the system.
- f. Make sure that the cylinder is situated on the scales before recovery takes place.
- g. Start the recovery machine and operate it in accordance with the manufacturer's instructions.
- h. Do not overfill cylinders with more than 80% volume liquid charge.
- i. Do not exceed the maximum working pressure of the cylinder, even temporarily.
- j. When the cylinders have been filled correctly and the process has been completed, make sure that the cylinders and the equipment are removed from site promptly and all isolation valves on the equipment are closed off.
- k. Recovered refrigerant shall not be charged into another refrigeration system unless it has been cleaned and checked.

Equipment shall be labeled stating that it has been de-commissioned and emptied of refrigerant. The label shall be dated and signed. Ensure that there are labels on the equipment stating the equipment contains flammable refrigerant.

When removing refrigerant from a system, either for servicing or decommissioning, it is recommended that all refrigerants are removed safely.

When transferring refrigerant into cylinders, ensure that only appropriate refrigerant recovery cylinders are employed. Ensure that the correct number of cylinders for holding the total system charge is available. All cylinders to be used are designated for the recovered refrigerant and labelled for that refrigerant (i.e. special cylinders for the recovery of refrigerant). Cylinders shall be complete with pressure-relief valve and associated shut-off valves in good working order. Empty recovery cylinders are evacuated and, if possible, cooled before recovery occurs.

**WARNING****Flammable refrigerant!**

The recovery equipment shall be in good working order with a set of instructions concerning the equipment that is at hand and shall be suitable for the recovery of the flammable refrigerant. If in doubt, the manufacturer should be consulted. In addition, a set of calibrated weighing scales shall be available and in good working order. Hoses shall be complete with leak-free disconnect couplings and in good condition.

The recovered refrigerant shall be processed according to local legislation in the correct recovery cylinder, and the relevant waste transfer note arranged. Do not mix refrigerants in recovery units and especially not in cylinders.

If compressors or compressor oils are to be removed, ensure that they have been evacuated to an acceptable level to make certain that flammable refrigerant does not remain within the lubricant. The compressor body shall not be heated by an open flame or other ignition sources to accelerate this process. When oil is drained from a system, it shall be carried out safely.

Do not use the heat pump for other purposes. In order to avoid any quality deterioration, do not use the unit for the cooling of precision instruments, food, plants, animals or works of art. Before cleaning, be sure to stop the operation, turn the breaker off or unplug the supply cord. Otherwise, electric shock and injury may occur.

To avoid electric shock or fire, make sure that a leak detector is installed. Never touch the air outlet or the horizontal blades while the swing flap is in operation. Fingers may be caught or the unit may break down.

Never put any objects into the air inlet or outlet. Objects touching the fan at high speed can be dangerous. Never inspect or service the unit by yourself. Ask a qualified service person to perform this task.

Do not dispose of this product as unsorted municipal waste. This waste should be collected separately for special treatment. Do not dispose of electrical appliances as unsorted municipal waste. Use separate collection facilities. Contact your local government for information regarding the connection systems available.

If electrical appliances are disposed of in landfills or dumps, hazardous substances can leak into the groundwater and get into the food chain, hazardous to one's health and well-being.

To prevent refrigerant leak, contact your dealer.

When the system is installed and operates in a small room, it is required to maintain the concentration of the refrigerant below the limit, in case a leak occurs. Otherwise, oxygen in the room may be affected, resulting in a serious accident.

The refrigerant in the heat pump is safe and normally does not leak.

If the refrigerant leaks into the room and encounters the fire of a burner, a heater or a cooker, a harmful gas could be released.

Turn off any combustible heating devices, ventilate the room, and contact the dealer where the unit was purchased.

Do not use the heat pump until a service person confirms that the refrigerant leak is repaired.

Keep ventilation openings clear of obstruction.

**WARNING****Product damage, personal injury!**

This outdoor unit must combine the indoor unit with refrigerant leak detection device.

These instructions are exclusively intended for qualified contractors and authorized installers. Work on the refrigerant circuit with mild flammable refrigerant in safety group A2L may only be carried out by authorized heating contractors. These heating contractors must be trained in accordance with UL 60335-2-40, Section HH. The certificate of competence from an industry accredited body is required.

Work on electrical equipment may only be carried out by a qualified electrician.

Before initial commissioning, all safety – related points must be checked by the particular certified heating contractors. The system must be commissioned by the system installer or a qualified person authorized by the installer.

2 Component Location

2.1 3 Ton Model

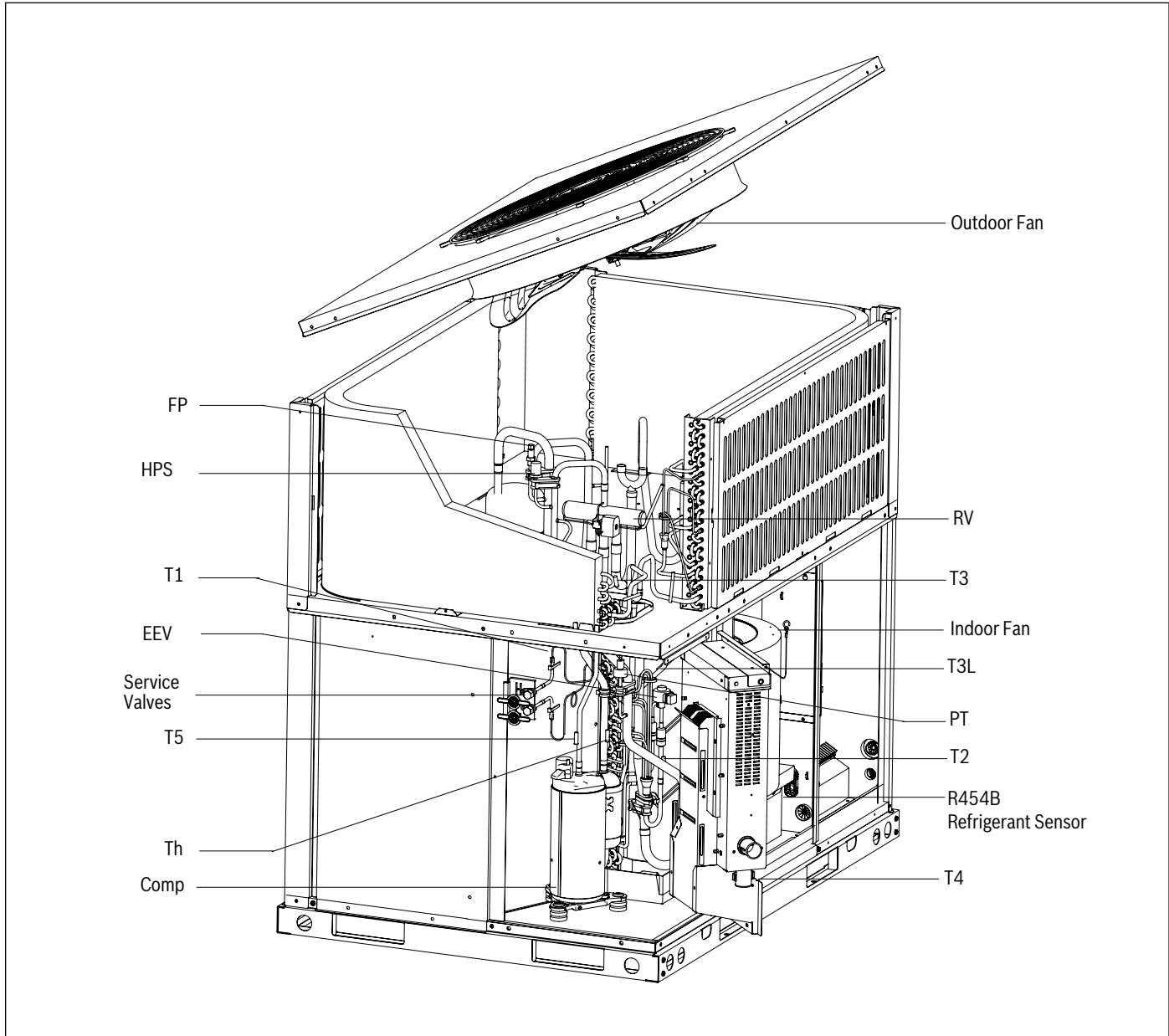

Figure 1

Component	Descriptions	Component	Descriptions
HPS	High pressure switch	T3L	Condenser outlet temp. sensor
PT	Pressure transducer	Th	Comp. return temp. sensor
T1	Return air temp. sensor	EEV	Electronic expansion valve
T2	Indoor coil temp. sensor	RV	Reversing valve
T3	Condenser temp. sensor	COMP	Compressor
T4	Ambient temp. sensor	FP	Fusible Plug
T5	Comp. discharge temp. sensor		

Table 2 Component Descriptions

2.2 5 Ton Model

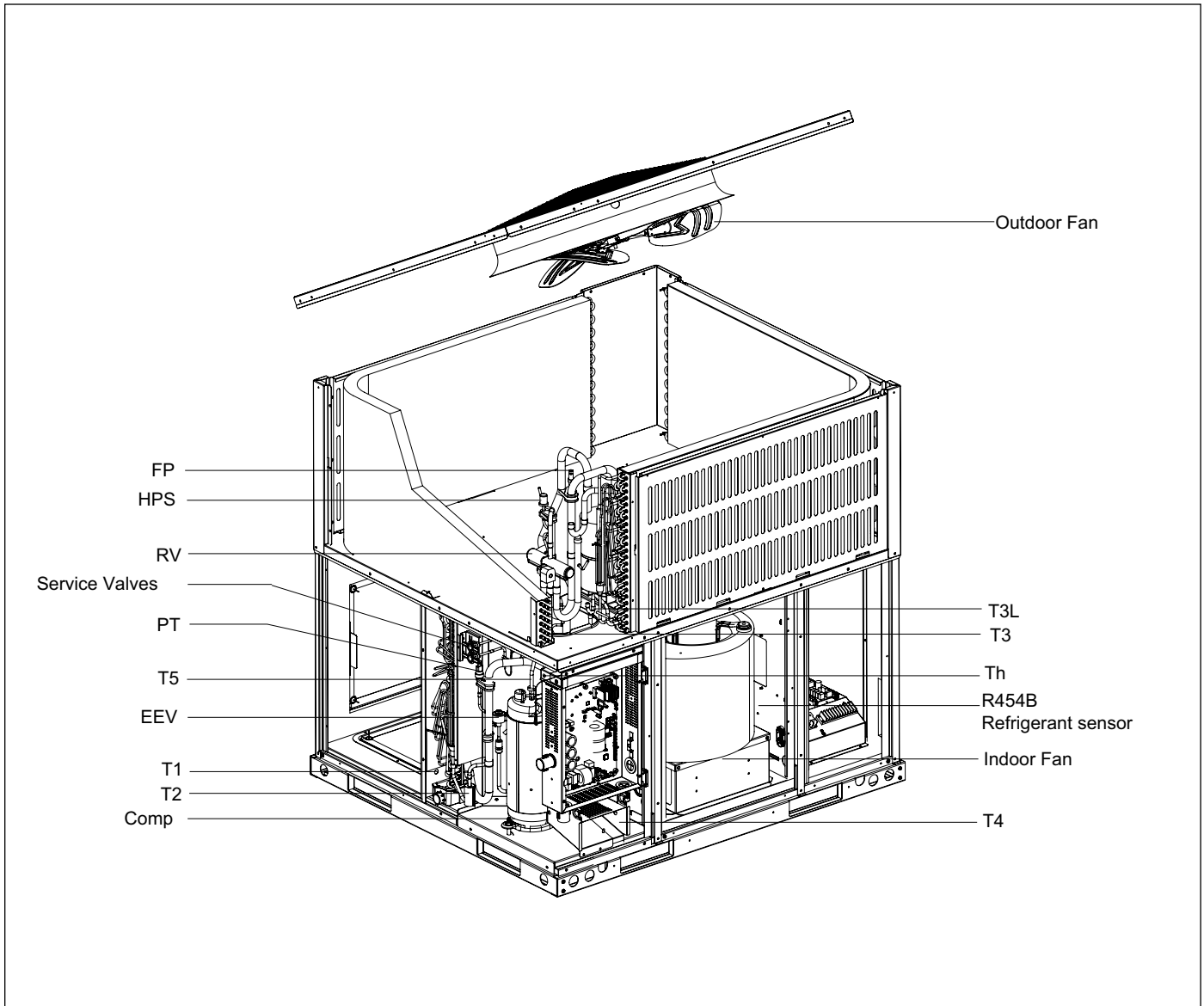

Figure 2

Component	Descriptions	Component	Descriptions
HPS	High pressure switch	T3L	Condenser outlet temp. sensor
PT	Pressure transducer	Th	Comp. return temp. sensor
T1	Return air temp. sensor	EEV	Electronic expansion valve
T2	Indoor coil temp. sensor	RV	Reversing valve
T3	Condenser temp. sensor	COMP	Compressor
T4	Ambient temp. sensor	FP	Fusible Plug
T5	Comp. discharge temp. sensor		

Table 3 Component Descriptions

3 Dimensions

3.1 3 Ton Model

3.1.1 Unit Dimensions

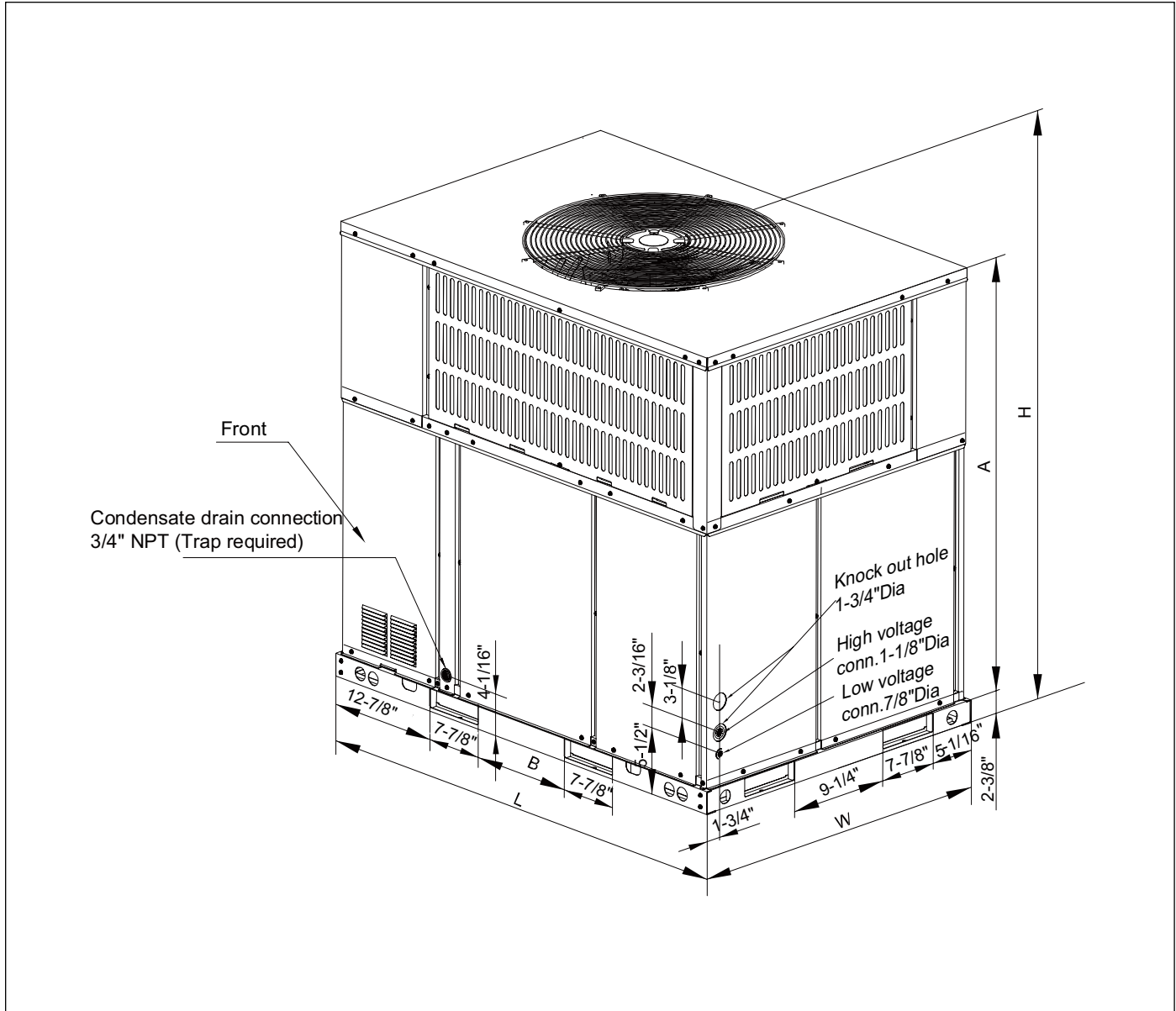

Figure 3

Heat Pump Model	L	W	H	A	B
3 Ton	50-11/16"	35-1/16"	46-13/16"	44-1/16"	9-1/4"

Table 4 Unit Dimensions

Heat Pump Model	Net Weight	Gross Weight
3 Ton	403 lbs (183 kg)	422 lbs (192 kg)

Table 5 Unit Weights

3.1.2 Dimensions - Back and Bottom

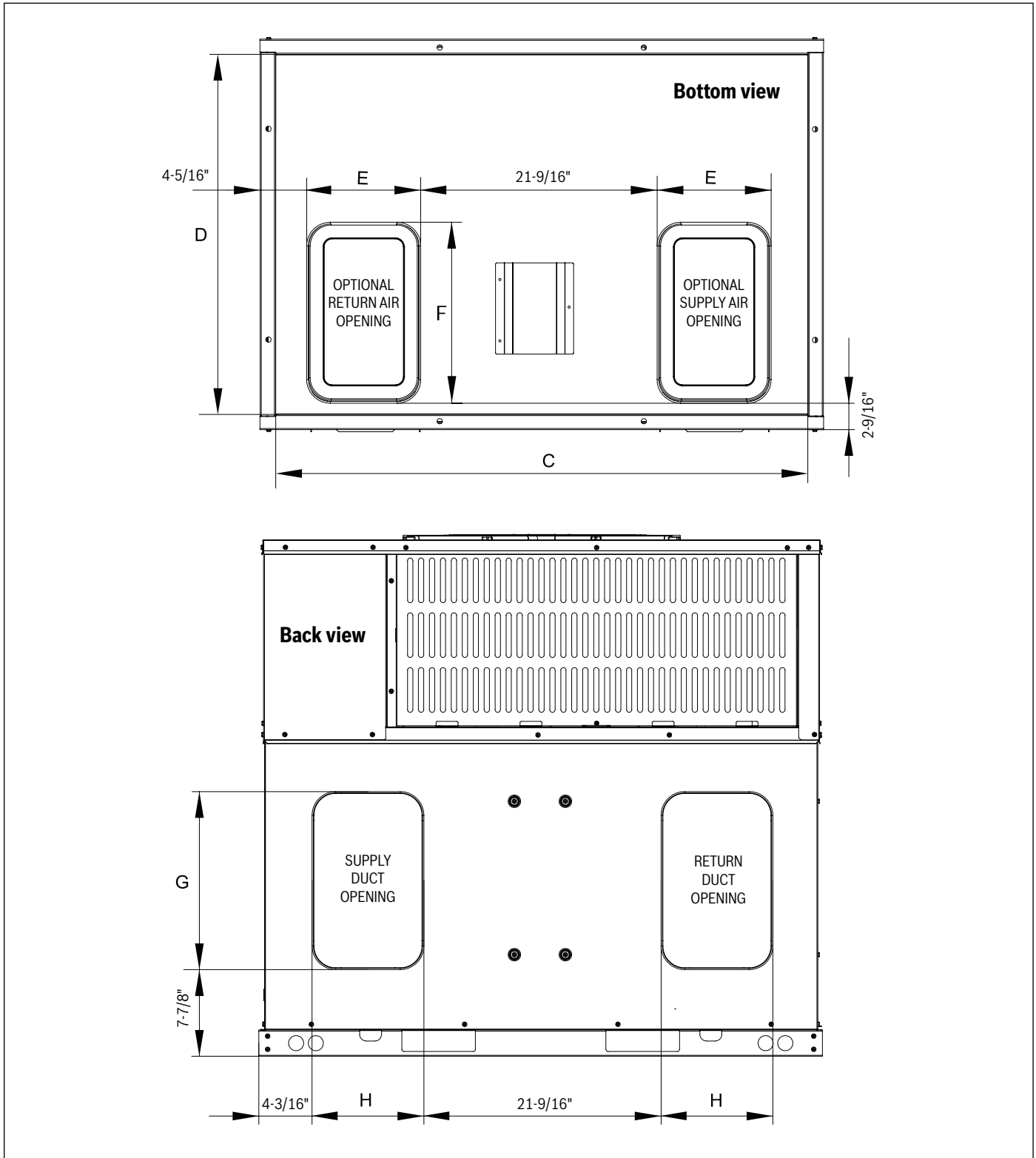

Figure 4

Heat Pump Model	C	D	E	F	G	H
3 Ton	47-13/16"	32-1/4"	9-15/16"	15-7/8"	15-3/4"	9-3/4"

Table 6 Dimensions - Back and Bottom

3.1.3 Dimensions - Left and Top

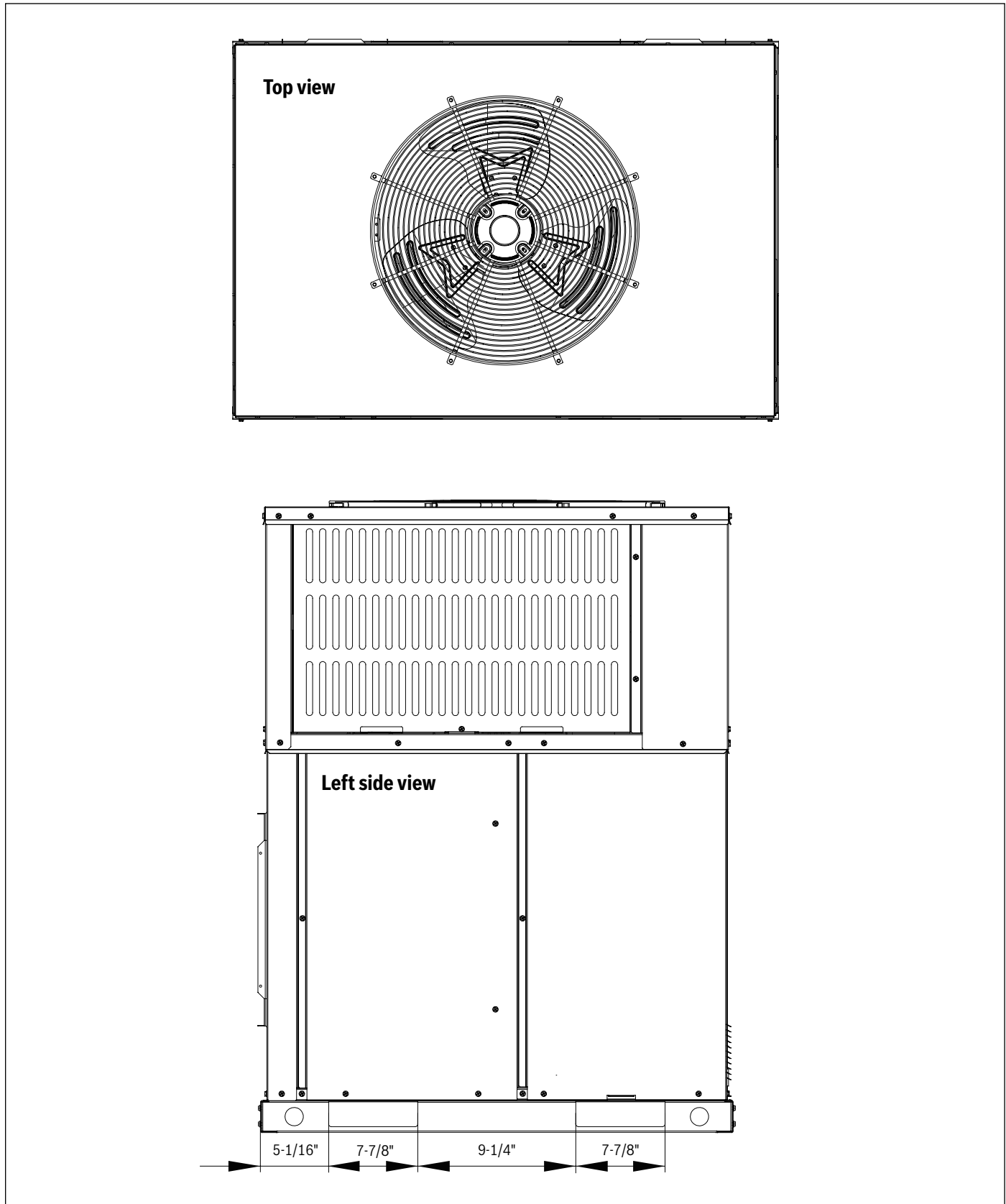

Figure 5

3.2 5 Ton Model

3.2.1 Unit Dimensions

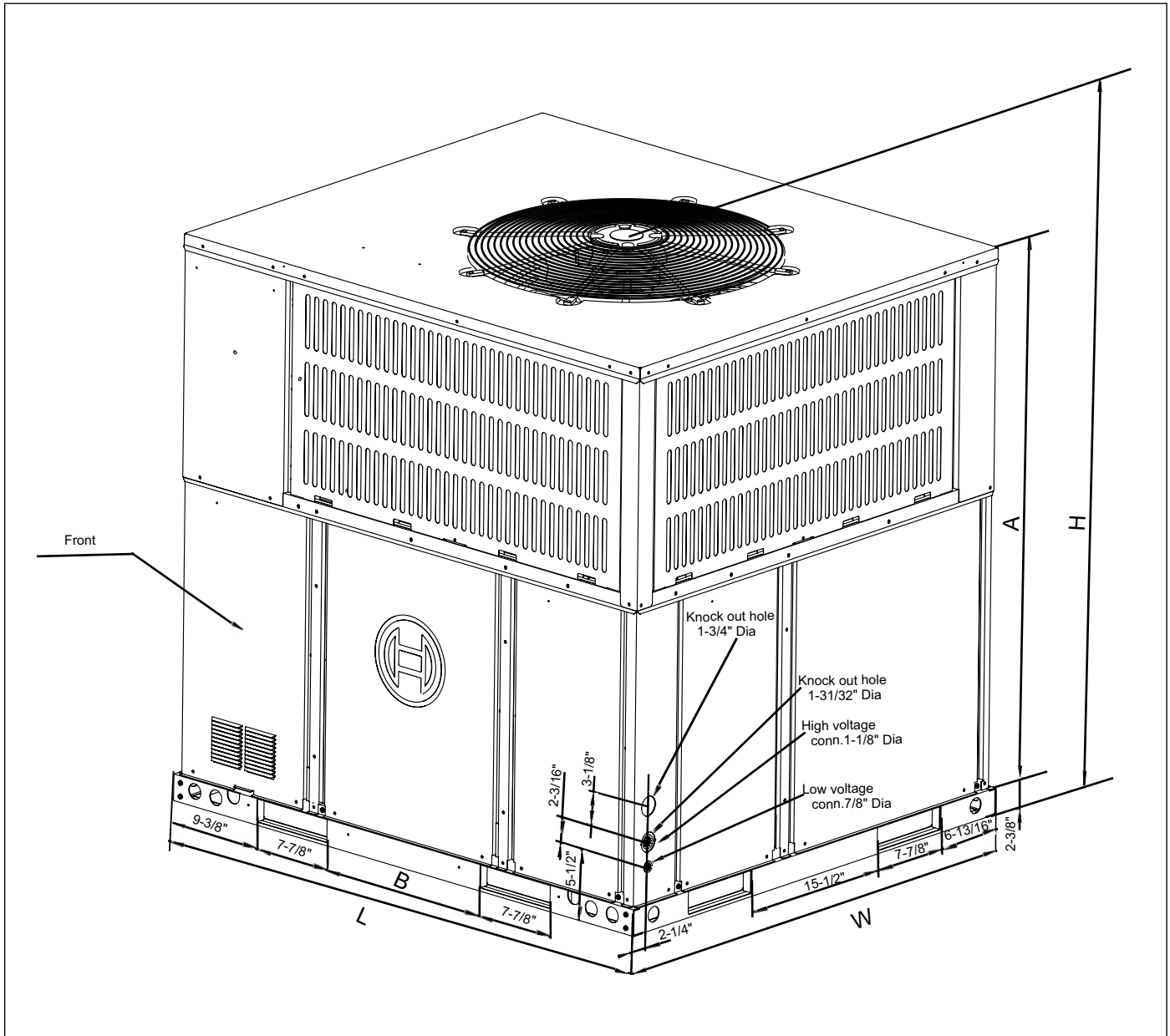

Figure 6

Heat Pump Model	L	W	H	A	B
5 Ton	51-9/16"	44-13/16"	51-7/16"	47-5/16"	17-3/16"

Table 7 Unit Dimensions

Heat Pump Model	Net Weight	Gross Weight
5 Ton	551 lbs (250 kg)	568 lbs (258 kg)

Table 8 Unit Weights

3.2.2 Dimensions - Back and Bottom

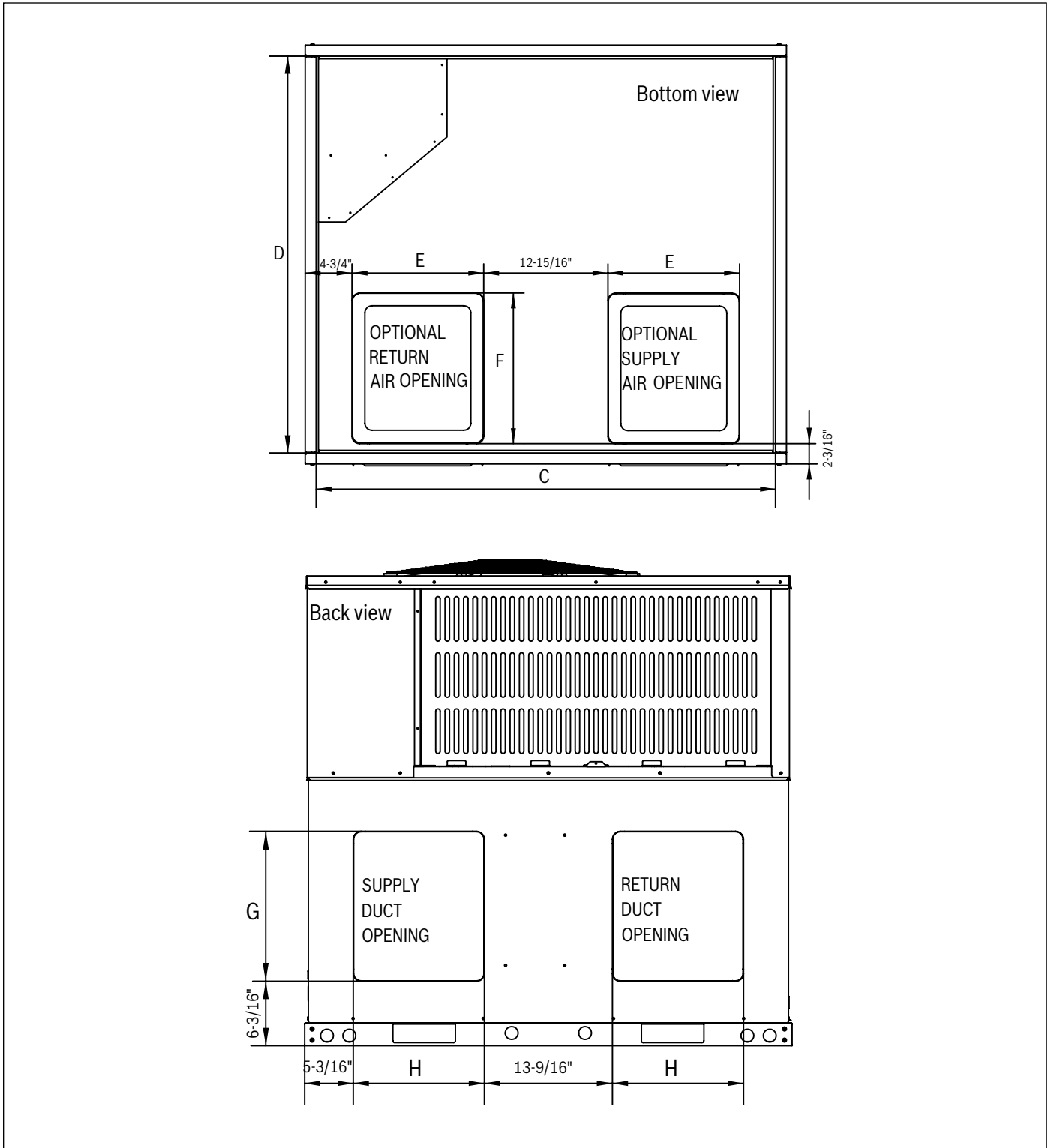

Figure 7

Heat Pump Model	C	D	E	F	G	H
5 Ton	49-1/4"	42-1/2"	14-1/8"	16-1/8"	15-7/8"	13-7/8"

Table 9 Dimensions - Back and Bottom

3.2.3 Dimensions - Right and Top

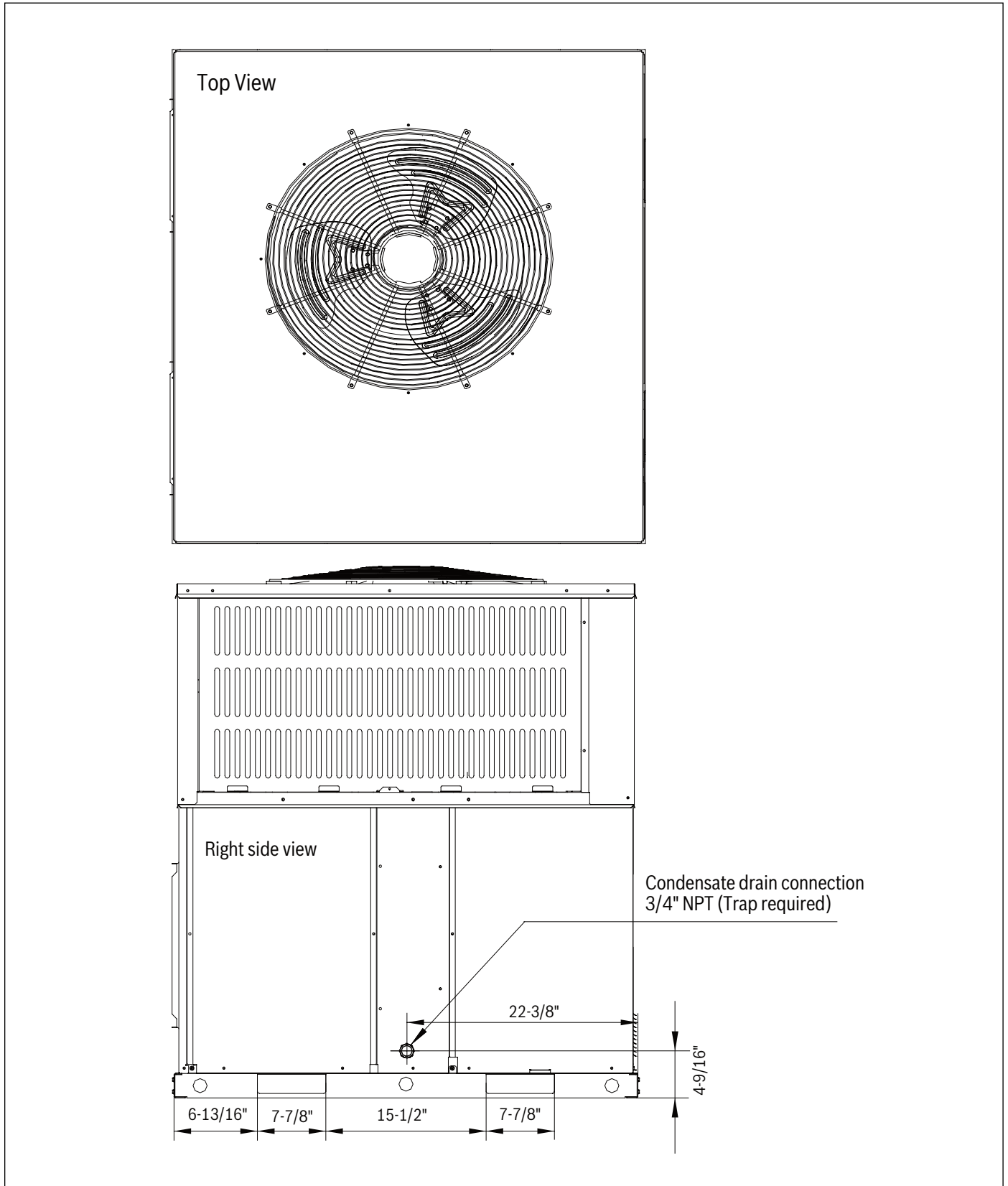

Figure 8

4 Bosch IDS Gateway Accessory and EasyAir Mobile App

This Heat Pump has connectivity features and is compliant with AHRI 1380 standard (Demand Response) when installed with the Gateway Accessory.

The Accessory can be ordered using the Part Number: 8733982717

Once the accessory is installed, Homeowners can download the Bosch EasyAir App on their smartphones to get started!

1. Refer to the “Gateway Accessory Installation Instructions” or scan the QR code below to learn more about installing the accessory.

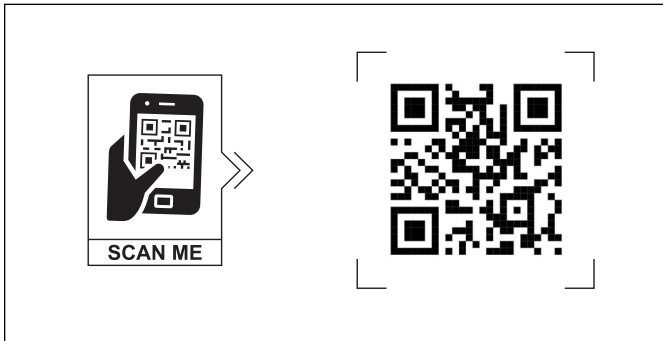

Figure 9

2. Download the Bosch EasyAir app on your smartphone by searching for it in Google Play Store (for Android devices) or App Store (for iPhone). Alternatively, you can scan this QR code with your phone's camera:

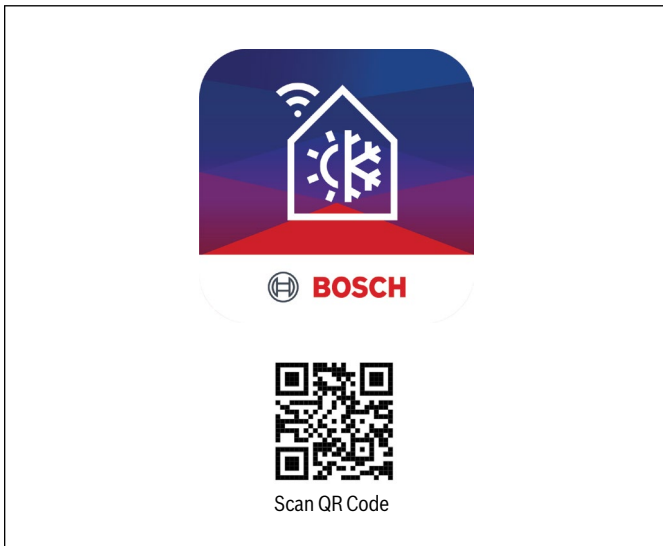

Figure 10

5 Installation

5.1 Pre-Installation

Before installation, carefully check the following:

1. Unit should be installed in accordance with national and local safety codes, including but not limited to ANSI/NFPA No. 70, local plumbing and wastewater codes and any other applicable codes.
2. For rooftop installation, be sure the structure has enough strength to support the weight of unit. Unit must be installed on a field supplied roof curb or rack and leveled.
3. For ground level installation, a field supplied level slab must be used.
4. Condenser airflow should not be restricted.
5. On applications when a roof curb is used, the unit must be positioned on the curb so the front of the unit is tight against the curb. If the unit is to be mounted on a curb in a downflow application, refer to Figure 19, and convert panels prior to rigging and lifting. The panel removal process may require the unit to be on the ground.

5.2 Rigging and Lifting

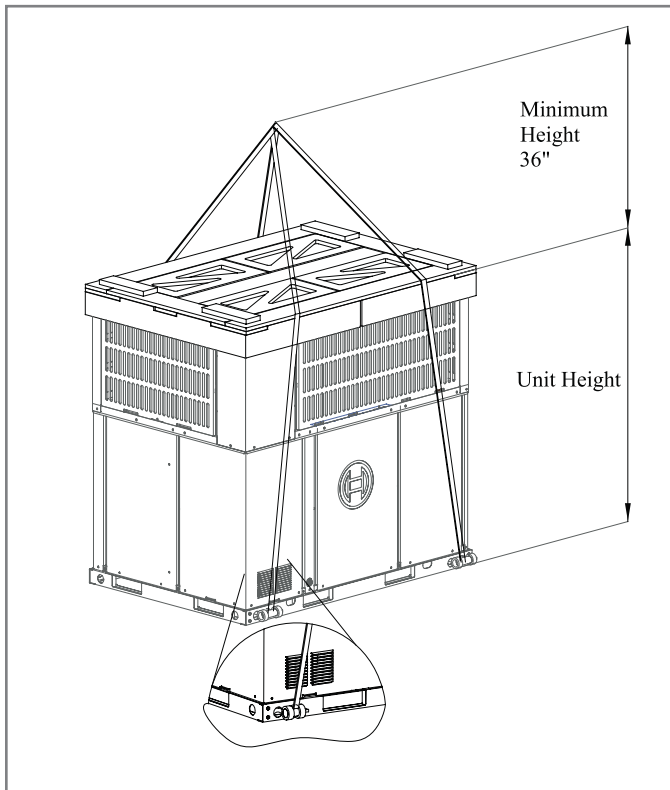

Figure 11

Exercise care when moving the unit. Do not remove any packaging until the unit is near the place of installation. Rig the unit by attaching chain or cable slings to the lifting holes provided in the base rails. Spreader bars, whose length exceeds the largest dimension across the unit, **MUST** be used across the top of the unit.

When rigging/lifting the unit, the minimum height between the top of the rigging cables' connection point and top of unit should be 36 inches. Refer to Figure 11.

CAUTION

Personal injury, product damage!

Before lifting, make sure the unit weight is distributed equally on the rigging cables so it will lift evenly.

NOTICE

Product damage!

All panels must be secured in place when the unit is lifted.

The condenser coils should be protected from rigging cable damage with plywood or other suitable material.

5.3 Location Restrictions

Ensure the top discharge area is unrestricted for at least 60 inches above the unit.

Do not locate outdoor unit near bedrooms since normal operational noise levels may be disturbing to building occupants.

Position unit to allow adequate space for unobstructed airflow, wiring, and serviceability.

Do not restrict outdoor airflow. An air restriction at either the outdoor air inlet or the fan discharge may be detrimental to compressor life.

Do not place the unit where water, ice, or snow from an overhang or roof will damage or flood the unit. Do not install the unit on carpeting or other combustible materials. Slab-mounted units should be at least 2 inches (51 mm) above the highest expected water and runoff levels. Do not use unit if it has been under water.

Maintain a distance of 24 inches between units. Position unit so water, snow, or ice from roof or overhang cannot fall directly on unit.

See Figure 13 and Figure 14 for minimum clearance requirements.

Cold climate considerations

NOTICE

Product damage!

Precautions must be taken for units being installed in areas where snow accumulation and prolonged below-freezing temperatures occur.

- Units should be elevated 3-12 inches above the pad or rooftop, depending on local weather. This additional height will allow drainage of snow and will permit condensate water to drain when the unit is in defrost mode. Ensure that drain holes in unit base pan are unobstructed, preventing drainage of defrost water (See Figure 15).
- If possible, avoid locations that are prone to snow drifts. If not possible, a snow drift barrier should be installed around the unit to prevent a build-up of snow on the sides of the unit.



Ensure that Condensate Drain side is pitched lower than the opposite side (see Figure 12).

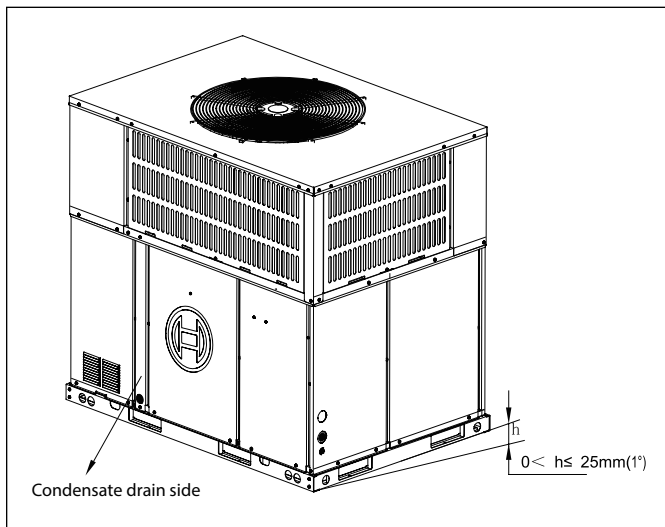

Figure 12

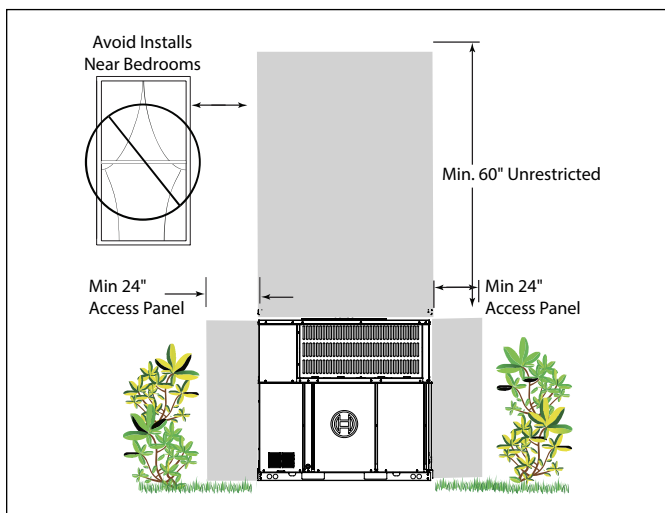

Figure 13



A minimum clearance of 24" should be maintained adjacent to all access/service panels. Refer to local code requirements for additional clearance requirements.

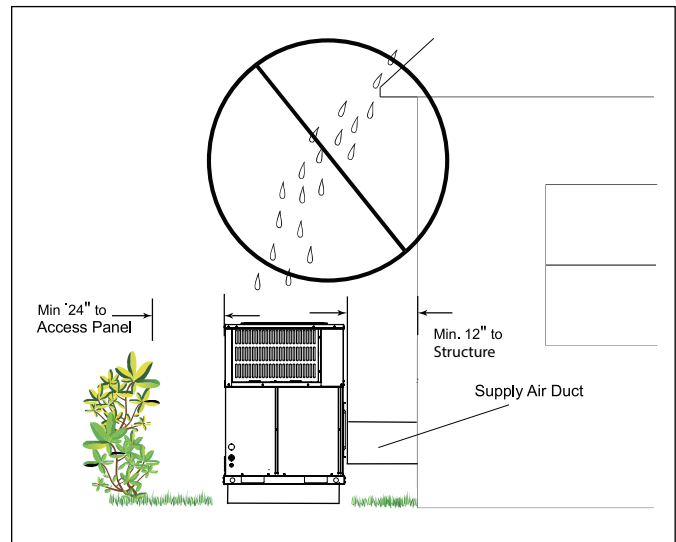

Figure 14

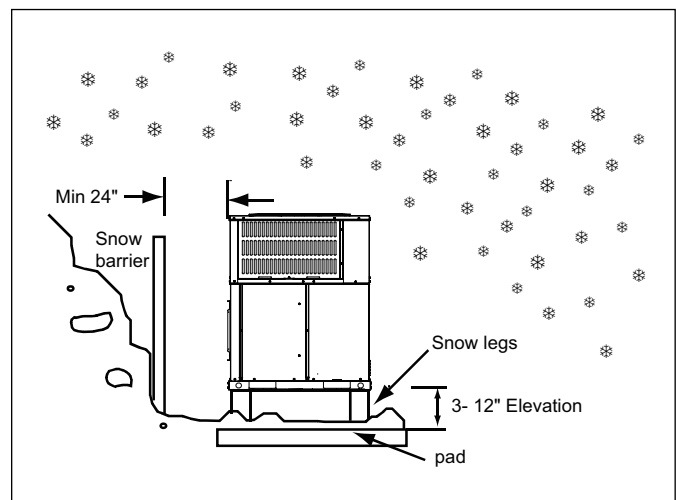

Figure 15 Insulation Layer

Corrosive Environment

Exposure to a corrosive environment may shorten the life of the equipment, corrode metal parts, and/or negatively affect unit performance. Corrosive elements include, but are not limited to: sodium chloride, sodium hydroxide, sodium sulfate, and other compounds commonly found in ocean water, sulfur, chlorine, fluorine, fertilizers, and various chemical contaminants from industry/manufacturing plants. If installed in areas which may be exposed to corrosive environments, special attention should be given to the equipment placement and maintenance.

- Lawn sprinklers/hoses/waste water should not spray directly on the unit cabinet for prolonged periods of time.
- In coastal areas: locate the unit on the side of the building or roof away from the waterfront.
- Fencing or shrubbery may provide some shielding protection to the unit, however minimum unit clearances must still be maintained.
- Every three months, wash the outdoor coil and any exposed cabinet surfaces.

5.4 Refrigerant Charge and Room Area Limitations

In UL/CSA 60335-2-40, R454B refrigerant is classified as class A2L, which is mildly flammable. Therefore, R454B refrigerant is suitable for systems needing additional refrigerant charge and which will limit the area of the rooms being served by the system.

Similarly, the total amount of refrigerant in the system shall be less than or equal to the allowable maximum refrigerant charge. The allowable maximum refrigerant charge depends on the area of the rooms being served by the system.

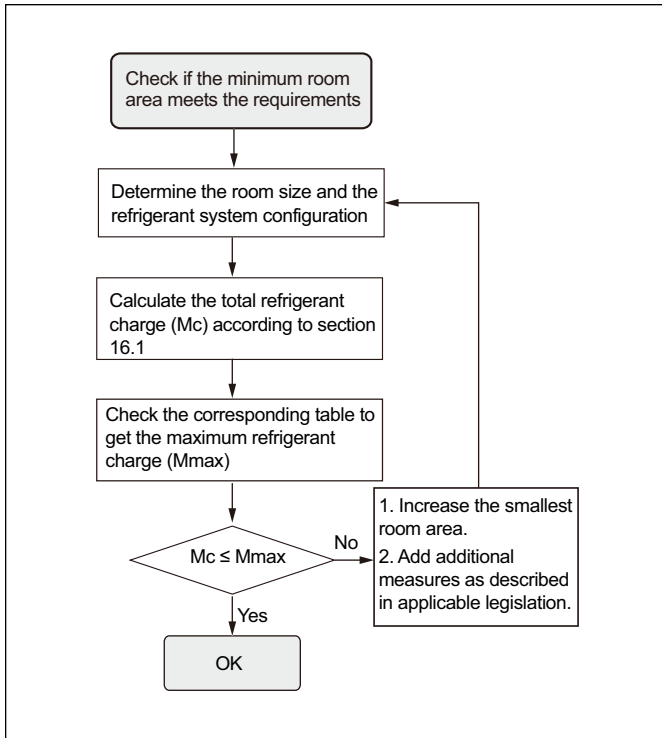

Figure 16



The terms in this section are explained as follows:

- **Mc:** The actual refrigerant charge in the system.
- **A:** the actual room area where the appliance is installed.
- **Amin:** The required minimum room area.
- **Mmax:** The allowable maximum refrigerant charge in a room.
- **Qmin:** The minimum circulation airflow.
- **Anvmin:** The minimum opening area for connected rooms.
- **TAmin:** The total area of the conditioned space (For appliances serving one or more rooms with an air duct system).
- **TA:** The total area of the conditioned space connected by air ducts.

5.4.1 The Room Area Calculation Requirements



Flammable refrigerant!

The space considered shall be any space which contains refrigerant-containing parts or into which refrigerant could be released.

The room area (A) of the smallest, enclosed, occupied space shall be used in the determination of the refrigerant quantity limits.

For determination of room area (A) when used to calculate the refrigerant charge limit, the following shall apply.

The room area (A) shall be defined as the room area enclosed by the projection to the base of the walls, partitions and doors of the space in which the appliance is installed.

Spaces connected by only drop ceilings, ductwork, or similar connections shall not be considered a single space.

Units mounted higher than 70-55/64 inches and spaces divided by partition walls that are no higher than 62-63/64 inches shall be considered a single space. Rooms on the same floor and connected by an open passageway between the spaces can be considered a single room when determining compliance to Amin, if the passageway complies with all of the following.

1. It is a permanent opening.
2. It extends to the floor.
3. It is intended for people to walk through.

The area of the connected rooms, on the same floor, connected by permanent opening in the walls and/or doors between occupied spaces, including gaps between the wall and the floor, can be considered a single room when determining compliance to Amin, provided all of the following conditions are met as shown in Figure 17.

Low level opening:

1. The opening shall not be less than Anvmin in Table 10.
2. The area of any openings above 11-13/16 inches from the floor shall not be considered in determining compliance with Anvmin.
3. At least 50% of the opening area of Anvmin shall be below 7-7/8 inches from the floor.
4. The bottom of the opening is not more than 3-15/16 inches from the floor.
5. The opening is a permanent opening that cannot be closed.
6. For openings extending to the floor the height shall not be less than 25/32 inches above the surface of the floor covering.

High level opening:

1. The opening shall not be less than 50% of Anvmin in Table 10.
2. The opening is a permanent opening that cannot be closed.
3. The opening shall be at least 59 inches above the floor.
4. The height of the opening is not less than 25/32 inches.

Room size requirement:

1. The room into which refrigerant can leak, plus the connected adjacent room(s) shall have a total area not less than Amin. Amin is shown in Table 12 to Table 14.
2. The room area in which the unit is installed shall be not less than 20% Amin. Amin is shown in Table 12 to Table 14.



The requirement for the second opening can be met by drop ceilings, ventilation ducts, or similar arrangements that provide an airflow path between the connected rooms.

The minimum opening for natural ventilation (Anv_{min}) in connected rooms is related to the room area (A), the actual refrigerant charge of refrigerant in the system (M_c), and the allowable MAXIMUM REFRIGERANT CHARGE in the system (M_{max}), Anv_{min} can be determined according to Table 10.

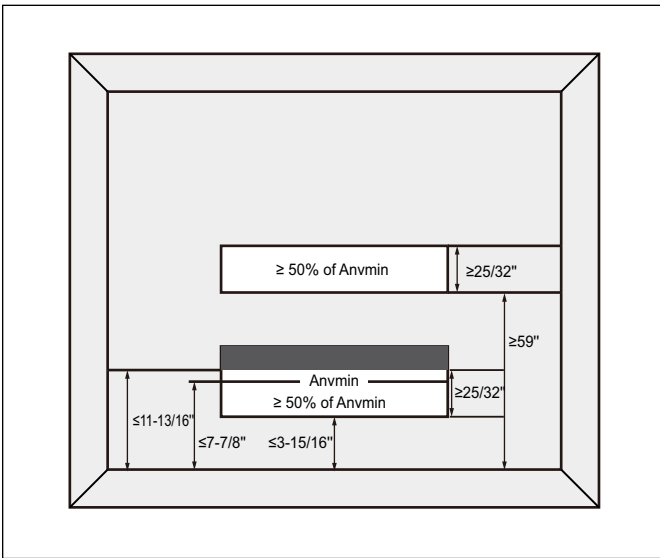

Figure 17

The minimum opening area for connected rooms:

A		m_c		m_{max}		Anv_{min}	
ft ²	m ²	lb-oz	kg	lb-oz	kg	ft ²	m ²
100	9.2	15-8	7	3-6	1.5	2.0	0.19
120	11.1	15-8	7	4-1	1.8	1.8	0.18
140	13.0	15-8	7	4-11	2.1	1.7	0.17
160	14.8	15-8	7	5-6	2.4	1.6	0.16
180	16.7	15-8	7	6-1	2.7	1.5	0.15
200	18.5	15-8	7	6-12	3.0	1.4	0.14
220	20.4	15-8	7	7-7	3.3	1.3	0.13
240	22.2	15-8	7	8-2	3.6	1.2	0.12
260	24.1	15-8	7	8-13	3.9	1.1	0.11
280	26.0	15-8	7	9-7	4.3	0.9	0.10
300	27.8	15-8	7	10-2	4.6	0.8	0.09
320	29.7	15-8	7	10-13	4.9	0.7	0.08
340	31.5	15-8	7	11-8	5.2	0.6	0.07
360	33.4	15-8	7	12-3	5.5	0.5	0.05
380	35.3	15-8	7	12-14	5.8	0.4	0.04
400	37.1	15-8	7	13-9	6.1	0.3	0.03
420	39.0	15-8	7	14-3	6.4	0.1	0.02
440	40.8	15-8	7	14-14	6.7	0.0	0.01
460	42.7	15-8	7	15-9	7.0	0.0	0.00

Table 10

Note: Take the $M_c=15lb\ 8oz$ as an example.

For appliances serving one or more rooms with an air duct system, The room area calculation shall be determined based on the total area of the conditioned space (TA) connected by ducts taking into consideration that the circulating airflow distributed to all the rooms by the appliance integral indoor fan will mix and dilute the leaking refrigerant before entering any room.

5.4.2 The Allowed Maximum Refrigerant Charge and Required Minimum Room Area

If the fan incorporated to an appliance is continuously operated or operation is initiated by a REFRIGERANT DETECTION SYSTEM with a sufficient CIRCULATION AIRFLOW rate, the allowable maximum refrigerant charge (M_{max}) and the required minimum room area (A_{min}/TA_{min}) is shown in Table 11 and Table 12 to Table 14.

The allowable maximum refrigerant charges:

A/TA		m_{max}		A/TA		m_{max}	
ft ²	m ²	lb-oz	kg	ft ²	m ²	lb-oz	kg
30	2.8	0-14	0.4	250	23.2	8-6	3.8
40	3.7	1-5	0.6	260	24.2	8-9	3.9
50	4.6	1-9	0.7	270	25.1	9-0	4.1
60	5.6	1-16	0.9	280	26.0	9-7	4.3
70	6.5	2-3	1	290	26.9	9-11	4.4
80	7.4	2-10	1.2	300	27.9	10-2	4.6
90	8.4	2-14	1.3	310	28.8	10-5	4.7
100	9.3	3-5	1.5	320	29.7	10-12	4.9
110	10.2	3-8	1.6	330	30.7	11-0	5.0
120	11.1	3-15	1.8	340	31.6	11-7	5.2
130	12.1	4-3	1.9	350	32.5	11-10	5.3
140	13.0	4-10	2.1	360	33.4	12-2	5.5
150	13.9	5-1	2.3	370	34.4	12-5	5.6
160	14.9	5-5	2.4	380	35.3	12-12	5.8
170	15.8	5-12	2.6	390	36.2	13-0	5.9
180	16.7	5-15	2.7	400	37.2	13-7	6.1
190	17.7	6-6	2.9	410	38.1	13-14	6.3
200	18.6	6-10	3.0	420	39.0	14-1	6.4
210	19.5	7-1	3.2	430	39.9	14-8	6.6
220	20.4	7-4	3.3	440	40.9	14-12	6.7
230	21.4	7-11	3.5	450	41.8	15-3	6.9
240	22.3	7-15	3.6	460	42.7	15-6	7.0

Table 11

The required minimum room area:

m_c		A_{min}/TA_{min}		m_c		A_{min}/TA_{min}	
lb-oz	kg	ft ²	m ²	lb-oz	kg	ft ²	m ²
2-2	1.0	65.1	6.1	10-2	4.6	299.1	27.8
2-9	1.2	78.1	7.3	10-9	4.8	312.1	29.0
3-0	1.4	91.1	8.5	11-0	5.0	325.1	30.3
3-7	1.6	104.1	9.7	11-7	5.2	338.2	31.5
3-15	1.8	117.1	10.9	11-14	5.4	351.2	32.7
4-6	2.0	130.1	12.1	12-5	5.6	364.2	33.9
4-13	2.2	143.1	13.3	12-12	5.8	377.2	35.1
5-4	2.4	156.1	14.5	13-3	6.0	390.2	36.3
5-11	2.6	169.1	15.8	13-10	6.2	403.2	37.5
6-2	2.8	182.1	17.0	14-1	6.4	416.2	38.7
6-9	3.0	195.1	18.2	14-8	6.6	429.2	39.9
7-0	3.2	208.1	19.4	14-15	6.8	442.2	41.1
7-7	3.4	221.1	20.6	15-6	7.0	455.2	42.3
7-15	3.6	234.1	21.8	15-14	7.2	468.2	43.5
8-6	3.8	247.1	23.0	16-5	7.4	481.2	44.7
8-13	4.0	260.1	24.2	16-12	7.6	494.2	46.0
9-4	4.2	273.1	25.4	17-3	7.8	507.2	47.2
9-11	4.4	286	26.6				

Table 12

The required minimum room area if installed at an altitude over 2000ft:

Altitude (m)		601-800		801-1000		1001-1200		1201-1400		1401-1600		1601-1800		1801-2000	
Altitude (ft)		1970-2625		2626-3280		3281-3938		3940-4593		4596-5250		5251-5905		5908-6562	
m_c		A_{min}/TA_{min}													
lb-oz	kg	ft ²	m ²	ft ²	m ²	ft ²	m ²	ft ²	m ²	ft ²	m ²	ft ²	m ²	ft ²	m ²
2	0.9	60.2	5.6	62.0	5.8	63.2	5.9	64.9	6.1	66.1	6.2	67.9	6.4	69.7	6.5
3	1.4	90.3	8.4	93.0	8.7	94.7	8.8	97.4	9.1	99.1	9.3	101.8	9.5	104.5	9.7
4	1.8	120.4	11.2	123.9	11.6	126.3	11.8	129.8	12.1	132.2	12.3	135.7	12.7	139.3	13.0
5	2.3	150.5	14.0	154.9	14.4	157.8	14.7	162.3	15.1	165.2	15.4	169.6	15.8	174.1	16.2
6	2.7	180.5	16.8	185.9	17.3	189.4	17.6	194.7	18.1	198.2	18.5	203.5	19.0	208.9	19.4
7	3.2	210.6	19.6	216.8	20.2	220.9	20.6	227.1	21.1	231.3	21.5	237.5	22.1	243.7	22.7
8	3.6	240.7	22.4	247.8	23.1	252.5	23.5	259.6	24.2	264.3	24.6	271.4	25.3	278.5	25.9
9	4.1	270.8	25.2	278.8	25.9	284.1	26.4	292.0	27.2	297.3	27.7	305.3	28.4	313.3	29.1
10	4.5	300.9	28.0	309.7	28.8	315.6	29.4	324.5	30.2	330.4	30.7	339.2	31.6	348.1	32.4
11	5.0	331.0	30.8	340.7	31.7	347.2	32.3	356.9	33.2	363.4	33.8	373.1	34.7	382.9	35.6
12	5.4	361.0	33.6	371.7	34.6	378.7	35.2	389.3	36.2	396.4	36.9	407.0	37.9	417.7	38.8
13	5.9	391.1	36.4	402.6	37.4	410.3	38.2	421.8	39.2	429.5	39.9	441.0	41.0	452.5	42.1
14	6.4	421.2	39.2	433.6	40.3	441.8	41.1	454.2	42.2	462.5	43.0	474.9	44.2	487.3	45.3
15	6.8	451.3	42.0	464.6	43.2	473.4	44.0	486.7	45.3	495.5	46.1	508.8	47.3	522.1	48.5
16	7.3	481.4	44.8	495.5	46.1	505.0	47.0	519.1	48.3	528.5	49.1	542.7	50.5	556.9	51.8
17	7.7	511.4	47.6	526.5	49.0	536.5	49.9	551.6	51.3	561.6	52.2	576.6	53.6	591.7	55.0
18	8.2	541.5	50.4	557.5	51.8	568.1	52.8	584.0	54.3	594.6	55.3	610.5	56.8	626.5	58.2
19	8.6	571.6	53.1	588.4	54.7	599.6	55.8	616.4	57.3	627.6	58.4	644.5	59.9	661.3	61.5
20	9.1	601.7	55.9	619.4	57.6	631.2	58.7	648.9	60.3	660.7	61.4	678.4	63.1	696.1	64.7

Table 13

Altitude (m)		2001-2200		2201-2400		2401-2600		2601-2800		2801-3000		3001-3200		above 3200	
Altitude (ft)		6565-7218		7221-7874		7877-8530		8533-9186		9190-9843		9846-10500		above 10500	
m_c		A_{min}/TA_{min}													
lb-oz	kg	ft ²	m ²	ft ²	m ²	ft ²	m ²	ft ²	m ²	ft ²	m ²	ft ²	m ²	ft ²	m ²
2	0.9	71.4	6.7	73.8	6.9	75.5	7.1	77.9	7.3	80.3	7.5	82.6	7.7	82.6	7.7
3	1.4	107.1	10.0	110.6	10.3	113.3	10.6	116.8	10.9	120.4	11.2	123.9	11.6	123.9	11.6
4	1.8	142.8	13.3	147.5	13.7	151.0	14.1	155.8	14.5	160.5	15.0	165.2	15.4	165.2	15.4
5	2.3	178.5	16.6	184.4	17.2	188.8	17.6	194.7	18.1	200.6	18.7	206.5	19.2	206.5	19.2
6	2.7	214.2	19.9	221.2	20.6	226.5	21.1	233.6	21.8	240.7	22.4	247.8	23.1	247.8	23.1
7	3.2	249.8	23.3	258.1	24.0	264.3	24.6	272.6	25.4	280.8	26.1	289.1	26.9	289.1	26.9
8	3.6	285.5	26.6	295.0	27.4	302.0	28.1	311.5	29.0	320.9	29.9	330.4	30.7	330.4	30.7
9	4.1	321.2	29.9	331.8	30.9	339.8	31.6	350.4	32.6	361.0	33.6	371.7	34.6	371.7	34.6
10	4.5	356.9	33.2	368.7	34.3	377.5	35.1	389.3	36.2	401.1	37.3	412.9	38.4	412.9	38.4
11	5.0	392.6	36.5	405.6	37.7	415.3	38.6	428.3	39.8	441.3	41.0	454.2	42.2	454.2	42.2
12	5.4	428.3	39.8	442.4	41.1	453.0	42.1	467.2	43.5	481.4	44.8	495.5	46.1	495.5	46.1
13	5.9	464.0	43.1	479.3	44.6	490.8	45.6	506.1	47.1	521.5	48.5	536.8	49.9	536.8	49.9
14	6.4	499.6	46.5	516.2	48.0	528.5	49.1	545.1	50.7	561.6	52.2	578.1	53.8	578.1	53.8
15	6.8	535.3	49.8	553.0	51.4	566.3	52.7	584.0	54.3	601.7	55.9	619.4	57.6	619.4	57.6
16	7.3	571.0	53.1	589.9	54.8	604.0	56.2	622.9	57.9	641.8	59.7	660.7	61.4	660.7	61.4
17	7.7	606.7	56.4	626.8	58.3	641.8	59.7	661.9	61.5	681.9	63.4	702.0	65.3	702.0	65.3
18	8.2	642.4	59.7	663.6	61.7	679.5	63.2	700.8	65.2	722.0	67.1	743.3	69.1	743.3	69.1
19	8.6	678.1	63.0	700.5	65.1	717.3	66.7	739.7	68.8	762.1	70.8	784.5	72.9	784.5	72.9
20	9.1	713.8	66.4	737.4	68.5	755.0	70.2	778.6	72.4	802.2	74.6	825.8	76.8	825.8	76.8

Table 14

The minimum circulation airflow:

m_c		Q_{min}		m_c		Q_{min}	
lb-oz	kg	CFM	m ³ /h	lb-oz	kg	CFM	m ³ /h
2-2	1.0	118	200	10-2	4.6	540	917
2-9	1.2	141	240	10-9	4.8	564	957
3-0	1.4	165	280	11-0	5.0	587	997
3-7	1.6	188	319	11-7	5.2	611	1037
3-15	1.8	212	359	11-14	5.4	634	1077
4-6	2.0	235	399	12-5	5.6	658	1117
4-13	2.2	259	439	12-12	5.8	681	1157
5-4	2.4	282	479	13-3	6.0	704	1197
5-11	2.6	306	519	13-10	6.2	728	1236
6-2	2.8	329	559	14-1	6.4	751	1276
6-9	3.0	352	599	14-8	6.6	775	1316
7-0	3.2	376	638	14-15	6.8	798	1356
7-7	3.4	399	678	15-6	7.0	822	1396
7-15	3.6	423	718	15-14	7.2	845	1436
8-6	3.8	446	758	16-5	7.4	869	1476
8-13	4.0	470	798	16-12	7.6	892	1515
9-4	4.2	493	838	17-3	7.8	916	1555
9-11	4.4	517	878				

Table 15



CAUTION

Min. room area and airflow required!

The allowable maximum refrigerant charge in Table 11 or the required minimum room area in Table 12 to Table 14 is available only if the following conditions are met:

Minimum velocity of 3.28ft/s, which is calculated as the indoor unit airflow divided by the nominal face area of the outlet. And the grill area shall not be deducted.

Minimum airflow rate must meet the corresponding values in Table 15, which is related to the actual refrigerant charge of the system (Mc).

R454B refrigerant leakage sensor is installed.



The maximum refrigerant limit described above applies to unventilated areas. If adding additional measures, such as areas with mechanical ventilation or natural ventilation, The maximum refrigerant charge can be increased or the minimum room area can be reduced.

R454B refrigerant leakage sensor is designed for the indoor unit, meets the incorporated circulation airflow requirements the maximum refrigerant charge or minimum room area can be determined according to Table 11 or Table 12 to Table 14.



CAUTION

Min. room area and airflow required!

If the actual room area, air outlet height, and refrigerant charge amount are not reflected in the above table, the most severe cases need to be considered according to the data in Table 10 through Table 15 .

5.5 Rooftop Installation - Curb Mounting

The manufacturer does not supply roof curbs, they must be field supplied. On applications when a roof curb is used, the unit must be positioned on the curb so the front of the unit is tight against the curb (see Figure 18 Roof Curb Dimension).

The default orientation from the factory is for horizontal airflow. Convert the unit to downflow using the following procedure:

1. Remove the sheet metal screws securing the supply air cover and the sheet metal screws securing the return air cover from the base of the unit. Remove the covers from the base. See Figure 19.
2. Place the covers over the horizontal supply and return openings (painted side out). Align the screw holes, and secure using the same screws removed in step 1. See Figure 19.

Install the field-supplied roof mounting curb according to the Installation Instructions supplied with the curb. Install insulation, cant strips, roofing, and flashing. Ductwork must be attached to curb.

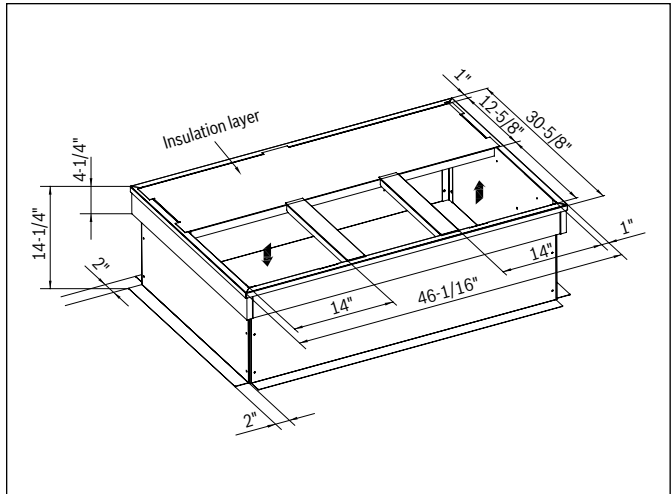

Figure 19 Roof Curb Dimensions



For units applied with a roof curb, the minimum clearance may be reduced from 1 inch to 1/2 inch between combustible roof curb material and supply air duct.

NOTICE

Property damage, product damage, improper operation!

The gasketing of the unit to the roof curb is critical for a water tight seal. Install gasketing material supplied with the field supplied roof curb. Improperly applied gasketing also can result in air leaks and poor unit performance.

NOTICE

Product damage!

The unit must be secured to the curb by installing screws through the bottom of the curb flange and into the unit base rails.

NOTICE

Product damage!

Failure to follow this caution may result in property damage. Ensure there is sufficient clearance for saw blade when cutting the outer horizontal flange of the roof curb so there is no damage to the roof or flashing.

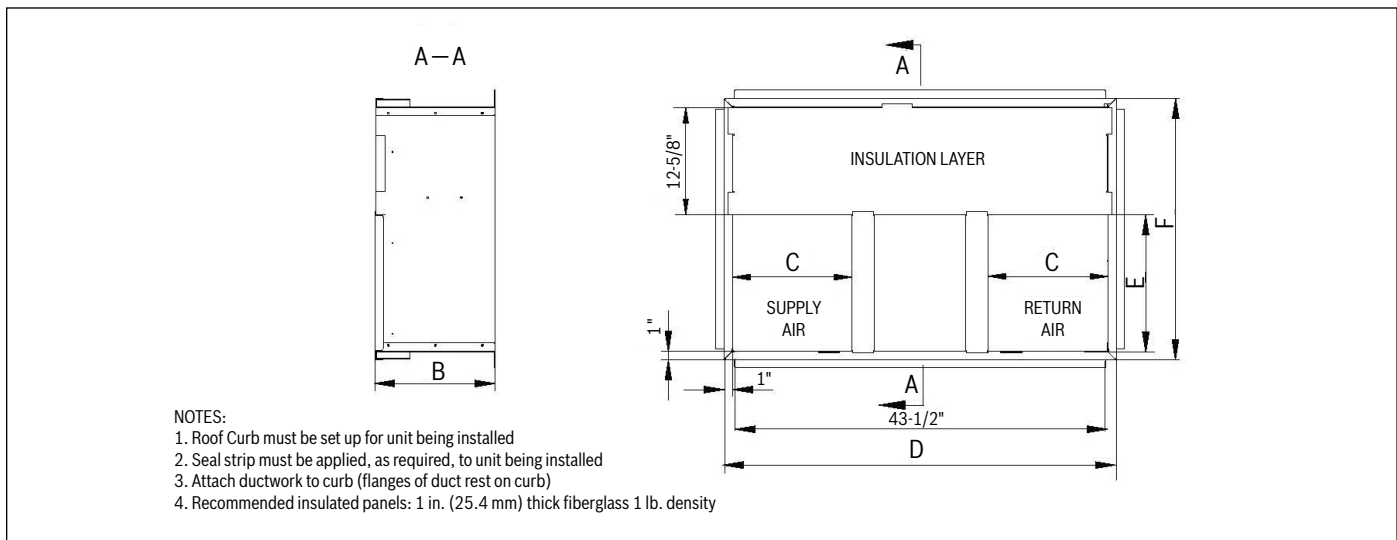

Figure 18 Roof Curb Details

Model	B	C	D	E	F
3 Ton	14-1/4"	14"	46-1/16"	16"	30-5/8"
5 Ton	14-1/4"	15-1/4"	46-1/16"	16"	42-3/16"

Table 16 Roof Curb Details - inches

6 Airflow Performance

Airflow performance data is based on cooling performance with a coil and no filter in place. Check the performance table for appropriate unit size selection.

External static pressure should stay within the minimum and maximum limits shown in the table below in order to ensure proper operation of both cooling, heating, and electric heating operation.

Model	Motor Speed*	SCFM											
		External Static Pressure-Inches W.C.											
		0.0	0.1	0.2	0.3	0.4	0.5	0.6	0.7	0.8	0.9	1.0	
3 Ton	Tap (1)	SCFM	863	782	720	644	549	452	381	334	306	261	231
		Current/A	1.41	1.44	1.46	1.48	1.51	1.55	1.57	1.59	1.62	1.65	1.67
		Power/W	100	110	110	120	120	130	130	134	140	144	150
	Tap (2)	SCFM	1144	1071	1003	955	897	836	763	686	608	546	493
		Current/A	1.93	1.96	1.99	2.02	2.06	2.1	2.13	2.17	2.21	2.26	2.3
		Power/W	190	200	205	210	220	220	230	230	240	249	250
	Tap (3)	SCFM	1291	1238	1159	1109	1068	1020	970	910	828	758	689
		Current/A	2.38	2.43	2.47	2.5	2.55	2.59	2.63	2.66	2.71	2.75	2.8
		Power/W	267	270	280	288	290	300	301	310	320	321	330
	Tap (4)	SCFM	1467	1419	1360	1293	1248	1212	1169	1124	1075	1022	964
		Current/A	3.1	3.15	3.19	3.24	3.28	3.33	3.38	3.42	3.46	3.5	3.58
		Power/W	374	380	390	399	400	410	420	420	430	436	450
	Tap (5)	SCFM	1537	1492	1440	1377	1327	1284	1230	1174	1115	1055	971
		Current/A	3.44	3.5	3.54	3.59	3.63	3.65	3.64	3.63	3.63	3.62	3.64
		Power/W	430	438	440	450	453	460	460	452	450	450	450
5 Ton	Tap (1)	SCFM	1324	1256	1182	1108	1042	971	894	806	743	688	614
		Current/A	1.76	1.81	1.88	1.94	1.99	2.05	2.12	2.19	2.24	2.28	2.34
		Power/W	170	180	190	200	210	220	230	240	250	259	265
	Tap (2)	SCFM	1426	1365	1298	1231	1161	1097	1027	953	876	813	761
		Current/A	1.99	2.05	2.11	2.17	2.23	2.3	2.38	2.46	2.53	2.58	2.63
		Power/W	210	220	230	240	250	260	270	280	290	300	310
	Tap (3)	SCFM	1604	1550	1494	1431	1372	1312	1253	1190	1126	1068	999
		Current/A	2.52	2.58	2.66	2.73	2.8	2.87	2.95	3.03	3.11	3.2	3.27
		Power/W	290	300	310	320	330	341	355	370	380	391	404
	Tap (4)	SCFM	1934	1892	1884	1797	1743	1690	1643	1591	1541	1485	1431
		Current/A	3.38	3.93	4.01	4.09	4.18	4.27	4.34	4.43	4.52	4.61	4.7
		Power/W	490	500	511	529	540	551	562	580	590	602	619
	Tap (5)	SCFM	2033	1985	1939	1892	1838	1788	1740	1687	1640	1593	1530
		Current/A	4.35	4.42	4.48	4.56	4.65	4.73	4.81	4.9	4.99	5.08	5.11
		Power/W	567	575	586	599	610	620	634	650	660	676	680

Table 17

 Bold outlined areas represent airflow outside of the required 300-450 cfm/ton range.

NOTES:

1. This table is only used to select the **highest blower speed**.
2. The rated airflow of systems without electric heater kits requires between 300 and 450 cfm/ton range. The rated airflow of systems with electric heater kits requires between 350 and 450 cfm/ton range.
3. The air distribution system has the greatest effect on airflow. Therefore, the contractor should use only industry-recognized procedures.
4. Duct design and construction should be carefully done. System performance can be lowered dramatically through poor design or workmanship.
5. Air supplier ducts should be located along the perimeter of the conditioned space and properly sized. Improper location or insufficient air flow may cause drafts or noise in the ductwork.
6. Installers should balance the air distribution system to ensure proper quiet airflow to all rooms in the home. An air velocity meter or airflow hood can be used to balance and verify branch and system airflow (CFM).

7 Indoor Fan Motor Function

System Operation and Function

This unit can run with either 4 Stage Fan Control or 2 Stage Fan Control. The factory default is 4 Stage Fan Control. To change the factory default parameters, refer to the information provided below.

Four Stage Fan Control

The IDP Premium supports up to 4 fan speeds. The fan speed will automatically change according to the temperature difference between T1 (return air temperature) and Ts (estimated thermostat set point). Higher differences in temperature between T1 and Ts relate to higher fan speeds. This fan control is supported by either a single or two stage thermostat.

The ECM Constant Torque motor has 5 selectable speed taps. The unit can use up to 4 fan speeds by setting the SW6-4 dip switch to the "ON" position (default). For determining the required airflow, refer to the Airflow Performance Table (Table 17). To select the fan speeds, change SW6-1 and SW6-2 dip switches, refer to Table 18 for dip switch speed configuration.

SW6-4	SW6-1	SW6-2	Model	High	Mid-High	Mid	Low
ON	OFF	OFF	Cool	2	1	1	1
			Heat	3	2	1	1
	OFF	ON	Cool	3	2	1	1
			Heat	4	3	2	1
	ON	OFF	Cool	4	3	2	1
			Heat	5	4	3	2
	ON	ON	Cool	5	4	3	2
			Heat	5	4	3	2

Table 18

*Note: Default Fan Speed is SW6-4 ON, SW6-1 ON, SW6-2 OFF

Two Stage Fan Control

The IDP Premium supports two stage fan control which requires a two stage thermostat (Y1&Y2). When there is a call for Y2, the blower motor will turn to high speed setting. When there is a call for Y1, the blower motor will turn to low speed setting. Unit will run at low speed setting when there is only G call. It will run in high speed setting when there is W/W1/W2 signal (when the electric heat kit is on).

Customers can select two stage fan control by setting the SW6-4 dip switch to the "OFF" position. Select the two fan speeds using the SW6-1 and SW6-2 dip switches, refer to Table 19. Refer to Airflow Performance Table (Table 17) for reference airflow.

If 2 stage thermostat is not available, single stage thermostat may be used, please refer to Wiring Diagram section for wiring instructions. If Y1 and Y2 are jumped, the unit will only run in high stage fan speed.

SW6-4	SW6-1	SW6-2	Model	High	Mid-High	Mid	Low
OFF	OFF	OFF	Cool	2	/	1	/
			Heat	3	/	1	/
	OFF	ON	Cool	3	/	1	/
			Heat	4	/	2	/
	ON	OFF	Cool	4	/	2	/
			Heat	5	/	3	/
	ON	ON	Cool	5	/	3	/
			Heat	5	/	3	/

Table 19

Anti-Cold Air Fan Delay

The Anti-Cold Air Fan Delay function utilizes a sensor (T2) located on the indoor coil and a pressure transducer (Pc) on the outdoor unit, which prevents the blower from turning on until the coil has reached a certain temperature. This feature prevents cold air blow during heating operation and is activated by setting SW6-3 dip switch to the "ON" position (default), refer to Table 20.

- When SW6-3 dip switch is set to the "ON" position and the unit is in heating mode, the Anti-Cold Air Fan Delay function will activate based on the following entry conditions (all 3 conditions must be met):
 - Indoor Coil Temperature (T2) < 83°F
 - Electric heat kit is turned off
 - There is a Y1 from the thermostat to the indoor unit
- This function will deactivate if ONE OF the following exit conditions are met:
 - T2 ≥ 90°F for more than 2 minutes
 - Heater kit is turned on
 - The system is NOT running Heat mode
 - There is no longer a Y1 from the thermostat to the indoor unit
 - There is a communication fault between indoor unit and outdoor unit
- During heating mode, the blower motor will turn on in first stage fan speed if one of the following conditions of Anti-Cold Air is satisfied:
 - T2 ≥ 90F
 - Pc ≥ 435 psi
 - Anti-Cold Air Fan Delay have been activated for 15 minutes

SW6-3	
ON*	Heat: Anti-Cold Air Fan Delay via Temp Sensor
OFF	Heat: Timed Fan Delay

Table 20

*Note: Default is ON

Heating Fan Delay

If SW6-3 dip switch is set to the "OFF" position (refer to Table 20), and the unit is in heating mode, the blower will operate with a 90 second delay with the fan speed dictated by Y1 or Y2 signal.

Dehumidification (Optional)

The IDP Premium has an active dehumidification function that lowers the evaporator temperature and slows down the fan speed to dehumidify the space with a DH call from the thermostat. This function requires proper DH wiring from the indoor unit to the thermostat (with a humidistat).



If DH wire is not connected, the unit will still function normally, but will not be able to run in dehumidification mode.

8 Ductwork

Field ductwork must comply with the National Fire Protection Association NFPA 90A, NFPA 90B and any applicable local ordinance(s).



WARNING

Fire hazard, carbon monoxide!

Do not, under any circumstances, connect return ductwork to any other heat producing device such as fireplace insert, stove, etc. Unauthorized use of such devices may result in fire, carbon monoxide poisoning, explosion, personal injury or property damage.

Sheet metal ductwork run in unconditioned spaces must be insulated and covered with a vapor barrier. Fibrous ductwork may be used if constructed and installed in accordance with SMACNA Construction Standard on Fibrous Glass Ducts. Ductwork must comply with National Fire Protection Association as tested by U/L Standard 181 for Class I Air Ducts. Check local codes for requirements on ductwork and insulation.

- Duct system must be designed within the range of external static pressure the unit is designed to operate against. It is important that the system airflow be adequate. Make sure supply and return ductwork, grills, special filters, accessories, etc. are accounted for in total resistance. See airflow performance tables in Section "6 Airflow Performance" on page 27 of this manual.
- Design the duct system in accordance with "ACCA" Manual "D" Design for Residential Winter and Summer Air Conditioning and Equipment Selection. Latest editions are available from: "ACCA" Air Conditioning Contractors of America, 1513 16th Street, N.W., Washington, D.C. 20036. If duct system incorporates flexible air duct, be sure pressure drop information (straight length plus all turns) shown in "ACCA" Manual "D" is accounted for in system.



If an elbow is included in the plenum close to the unit, it must not be smaller than the dimensions of the supply duct flange on the unit.

NOTICE

Product damage!

The front flange on the return duct (if connected to the blower housing) must not be screwed into the area where the power wiring is located. Drills or sharp screw points can damage insulation on wires located inside unit.

- Secure all ducts to roof curb and building structure on downflow discharge units. Do not connect ductwork to unit. For horizontal applications, unit is provided with flanges on the horizontal openings. All ductwork should be secured to the flanges using proper fasteners for the type of duct used and tape the duct-to unit joint as required to prevent air leaks.

NOTICE

Product damage!

When fastening ductwork to the side duct flanges on the unit, insert the screws through the duct flanges only. DO NOT insert the screws through the casing. Outdoor ductwork must be insulated and waterproofed.



Be sure to note supply and return openings. Refer to Section "3 Dimensions" on page 12 for information concerning supply and return air duct dimensions.

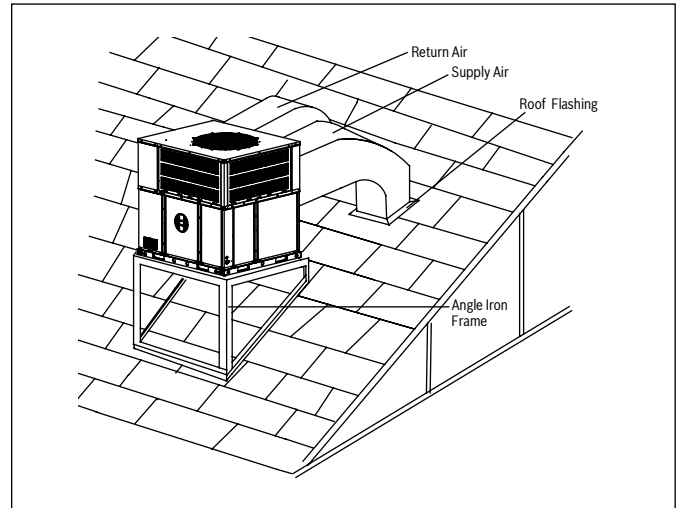

Figure 20 Rooftop Installation - Frame Mounting

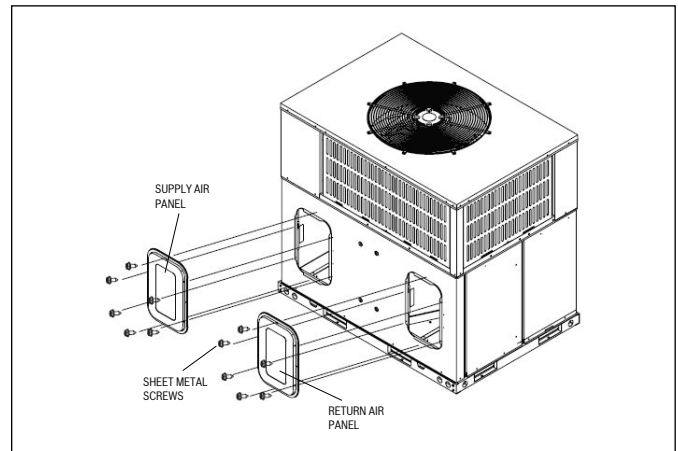

Figure 21

Note: Refer to downflow conversion instructions provided with the unit

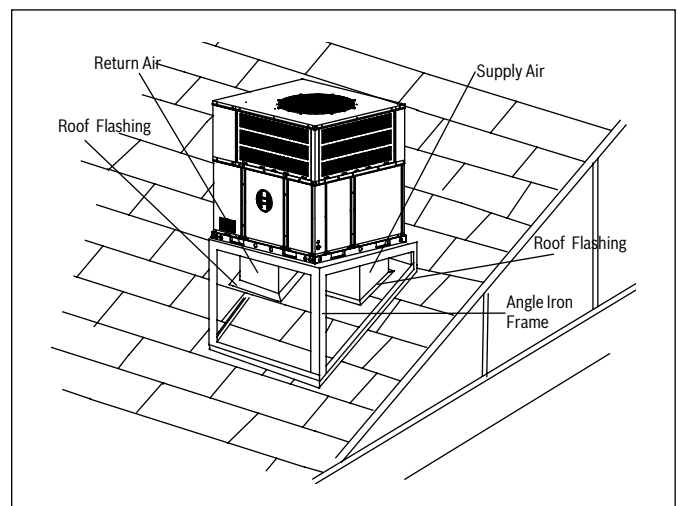

Figure 22 Typical Rooftop Downflow Application with Frame

NOTICE

Product damage!

A unit with electric heaters with an inlet or outlet duct that penetrates the building structure supporting the unit shall be provided with a mounting base of noncombustible material so designed that, after the unit is installed, there will be no open passages through the supporting structure that would permit flame or hot gases from a fire originating in the space below the supporting structure to travel to the space above that structure. If the unit is intended to be installed on a supporting structure of combustible material, the base shall be so designed that the required clearance will be maintained between the supporting unit mounting base, and shall extend not less than 76 mm(3 in) below the upper surface of the supporting structure, except that, in a unit designed for use only in a mobile home, the distance shall be not less than 19 mm(3/4 in).

9 Condensate Drain Connection

Unit should be installed in accordance with national and local safety codes, including but not limited to ANSI/NFPA No. 70, local plumbing and wastewater codes and any other applicable codes.

9.1 Install Drain Pipe

1. Ensure drain lines do not block access to front of the unit. Minimum clearance of 24 inches is required for filter, coil or blower removal and service access.
2. Make sure unit is leveled or pitched slightly towards primary drain connection so that water will drain completely from the pan.
3. Do not reduce drain line size to less than connection size provided on condensate drain pan.
4. All drain lines must be pitched downward away from the unit at a minimum of 1/8" per foot of line to ensure proper drainage.
5. Do not connect condensate drain line to a closed or open sewer pipe. Run condensate to an open drain or run line to a safe outdoor area.
6. The drain line should be insulated where necessary to prevent sweating and damage due to condensate forming on the outside surface of the line.
7. Make provisions for disconnecting and cleaning of the primary drain line should it become necessary. Install a 2 inch trap in the primary drain line as close to the unit as possible. Make sure that the top of the trap is below connection to the drain pan to allow complete drainage of pan.

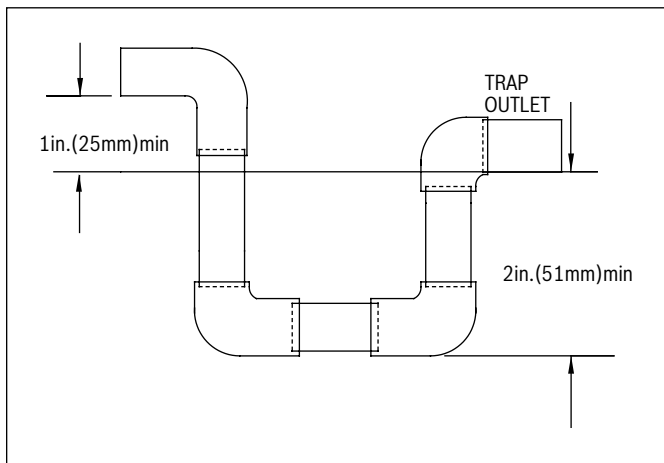

Figure 23



When making drain fitting connections to the drain pan, use a thin layer of Teflon paste, silicone or Teflon tape and install by hand tightening.



When making drain fitting connections to drain pan, do not overtighten. Overtightening fittings can split pipe connections on the drain pan.

10 Air Filter (Not Factory-Installed)

Filters and filter racks are not included with the unit and must be field supplied.

An external filter or other means of filtration must be properly sized for a maximum of 300 feet/min. air velocity or what is recommended for the type of filter installed.

Filter application and placement are critical to airflow, which may affect the heating and cooling system performance. Reduced airflow can shorten the life of the system's major components, such as motor, elements, heat relays, evaporator coil or compressor. Consequently, we recommend that the return air duct system have only one filter location. For systems without a return air filter grill, multiple filter grills can be installed at each of the return air openings.

If adding high efficiency filters or electronic air filtration systems, it is very important that the air flow is not reduced. If air flow is reduced the overall performance and efficiency of the unit will be reduced. It is strongly recommended that a professional installation technician is contacted to ensure such filtration systems are installed correctly.



Do not double filter the return air duct system. Do not filter the supply air duct system. This will change the performance of the unit and reduce airflow.

WARNING

Risk of fire!

Do not operate the system without filters. A portion of the dust suspended in the air may temporarily lodge in the duct runs and at the supply registers. Any circulated dust particles could be heated and charred by contact with the air handler elements. This residue could soil ceilings, walls, drapes, carpets and other articles in the house. Soot damage may occur with filters in place, when certain types of candles, oil lamps or standing pilots are burned.

Heat Pump Model	No.	Size Recommended in.
3 Ton	1	16"x10"x1"
5 Ton	1	16"x14"x1"

Table 21

11 Electrical Wiring

Field wiring must comply with the National Electric Code (NEC) and any applicable local ordinance.



WARNING

Electrical shock!

Disconnect all power to unit before installing or servicing. More than one disconnect switch may be required to de-energize the equipment. Hazardous voltage can cause severe personal injury or death.

11.1 Power Wiring

1. It is important that proper electrical power is available for connection to the unit being installed. See the unit nameplate, wiring diagram, and electrical data in the installation instructions for more detailed requirements. Voltage tolerance should not be over 10% from rating voltage.
2. If any of the wiring must be replaced, replacement wiring must be the same type as shown in nameplate, wiring diagram and electrical data sheet.
3. Install a branch circuit disconnect of adequate size to handle starting current, located within sight, and readily accessible to the unit.
4. **Electric Heater:** If the optional Electric Heat Kit is installed, the unit should be equipped with suitable circuit breakers or fuse. Refer to Table 23 and 24 for more information. These breaker(s) protect the internal wiring in the event of a short circuit and serve as a disconnect. Circuit breakers installed within the unit do not provide over-current protection of the supply wiring and therefore may be sized larger than the branch circuit protection.
 - Supply circuit power wiring must be 221 °F minimum copper conductors only. Refer to Table 23 and Table 24 for ampacity, wire size and circuit protector requirements. Supply circuit protective devices may be either fuses or "HACR" type circuit breakers. 1-3/8" knockouts inside the cabinet are provided for connection of power wiring to electric heater.
 - Power wiring is connected to the power terminal block in unit electric cabinet. See Electric Heater Kit Installation Instructions for details.
5. See wiring diagram located on inside of control board access panel for proper wiring instructions.

11.2 Grounding



WARNING

Electrical shock!

The unit must be permanently grounded. Failure to do so can result in electrical shock causing personal injury or death.

- The unit must be electrically grounded in accordance with local codes and the National Electric Code (NEC).
- Grounding may be accomplished by attaching ground wire(s) to ground lug(s) provided in the unit wiring compartment.

11.3 Control Wiring



WARNING

Fire hazard!

Low voltage control wiring should not be run in conduit with high voltage wiring. Keep distance between the two conduits per local codes.

- 18 AWG. color-coded low voltage wire should be used for lengths less than 100 ft. For wire lengths longer than 100 ft., 16 AWG. wire should be used.
- 7/8" knockout hole should be used to route control wires into the unit.
- After installation, ensure separation of low voltage and high voltage wiring is maintained.

Refer to Figure 25 for thermostat wiring diagrams.

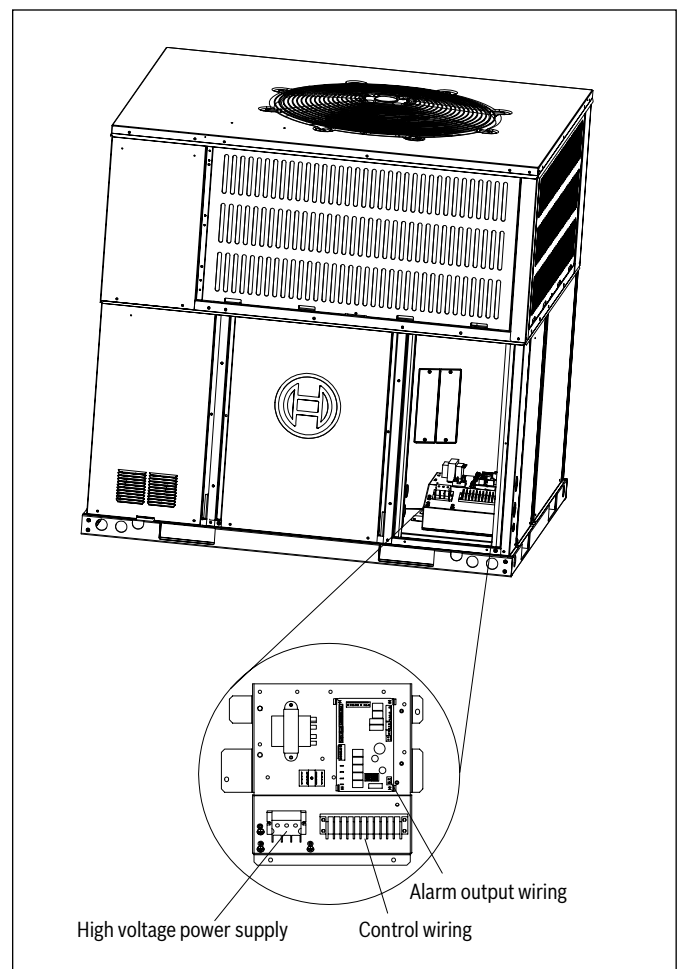

Figure 24

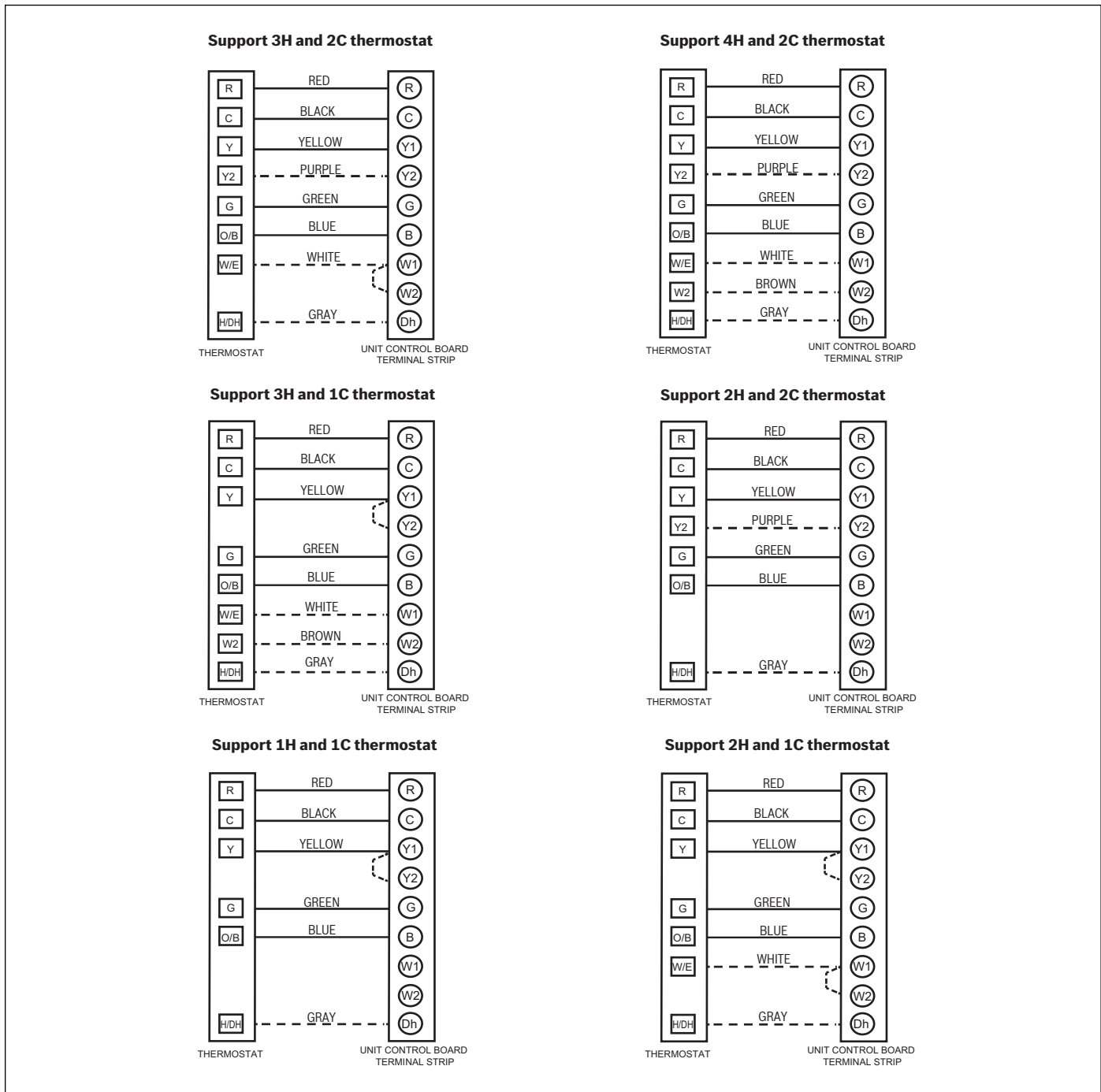

Figure 25 Thermostat Wiring Diagrams

i Dh wiring is optional and requires a thermostat with a humidistat. Dh functions as Active Dehumidification and will downstage the indoor fan speed and lower the evaporator coil temperature. System will operate according to normal sequence of operations if Dh wiring is absent.

i Y2 wiring is optional for 4 speed fan control. For 2 stage fan control Y2 wiring is required.

i Dashed lines in the above thermostat wiring diagrams refer to optional wiring (wiring for Dehumidification Function, Electric Heat, and 2 stage fan control). For thermostat wiring please refer to the Owner’s Manual of the thermostat.

i B wire must be connected, the reversing valve energizes in heating.



WARNING

Electrical shock!

Label all wiring prior to disconnection when servicing controls. Wiring errors can cause improper and dangerous operation. Verify proper operation after servicing.

Size (Tons)	Voltage - Phase - Frequency	Compressors (each)		OD Fan Motors (each)	Supply Blower Motor	Unit Circuit	
		RLA	LRA	FLA	FLA	MCA ¹ (Amps)	Max Fuse ² / Breaker ³ Size (Amps)
36 (3.0)	208/230-1-60	19.0	52.0	1.8	3.9	30.0	35
60 (5.0)	208/230-1-60	27.0	52.0	2.0	5.3	42.0	50

Table 22 Electrical Data Without Electric Heat

Heater Circuit without units - Dual Point (208V/240V)					
Model	kW	Stages	Amps	"MCA ¹ (Amps)"	Max Fuse ² / Breaker ³ Size (Amps)*
EHK-05J	3.8/5	1	18.1/20.8	23/26	25/30
EHK-08J	5.6/7.5	1	27.1/31.3	34/40	35/40
EHK-10J	7.5/1.0	1	36.1/41.7	46/53	50/60
EHK-15J	11.3/15	2	54.2/62.5	68/79	70/80
EHK-20J	15/20	2	72.2/83.3	91/105	100/110

Table 23 Electric Heat Kit Data without Unit

Heater Circuit with units - Single Point (208/240 V)						
Size	EHK Model	EHK Power (kW)	Stages	EHK Circuit (Amps)	MCA With EHK (Amps)	Max Fuse/ Breaker Size With EHK (Amps)
36K (3Ton)	EHK-05J	3.8/5	1	18.1/20.8	52/56	60/60
	EHK-08J	5.6/7.5	1	27.1/31.3	64/69	70/70
	EHK-10J	7.5/10	1	36.1/41.7	75/82	80/90
	EHK-15J	11.3/15	2	54.2/62.5	98/108	100/110
60K (5Ton)	EHK-05J	3.8/5	1	18.1/20.8	64/68	70/80
	EHK-08J	5.6/7.5	1	27.1/31.3	75/81	90/90
	EHK-10J	7.5/10	1	36.1/41.7	87/94	100/100
	EHK-15J	11.3/15	2	54.2/62.5	109/120	110/125
	EHK-20J	15/20	2	72.2/83.3	132/146	150/150

Table 24 Electrical Data With Electric Heat

1. Minimum Circuit Ampacity.
2. Maximum Over Current Protection per Standard UL 60335.
3. Fuse or HACR circuit breaker size field installed.

* Max Fuse/Breaker Sizes are for electric heater ONLY (dual point electric heat). DOES NOT include breaker size for the unit.

** Max Fuse/Breaker Sizes include breaker size for the unit AND electric heat (single point electric heat).



Refer to Electric Heat Kit Installation Manual, some heater kits include fuses from the manufacturer.



WARNING

Electrical shock, fire hazard!

Any power supply and circuits must be wired and protected in accordance with federal, state and local electrical codes.

The Alarm port is a switch that closes when the refrigerant leakage protection is triggered. An appropriate remote controller or alertror could be chose to link to the alarm port.

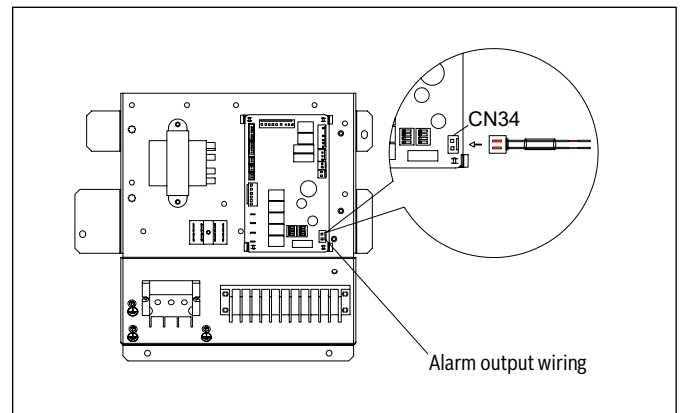

Figure 26



CAUTION

Electrical shock, fire hazard!

The rated operating condition of ALARM is 24 V AC/1 A or 30 V DC/1A or 250 V AC/1 A. The type of wiring for ext output should use cables of AWG 18 (Min. AWG 18).

12 Start Up

12.1 System Start Up

1. Ensure Sections 5 to 11 have been completed.
2. Set System Thermostat to OFF.

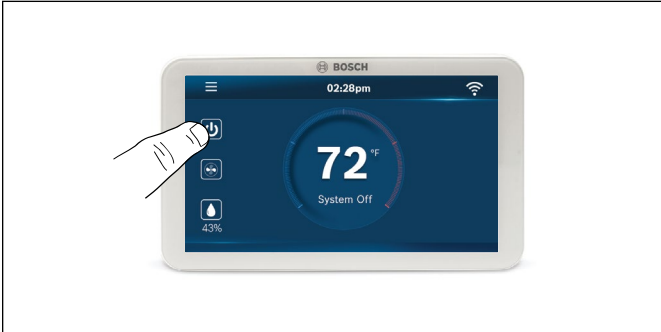

Figure 27

3. Turn on disconnect to apply power to the indoor and outdoor units.

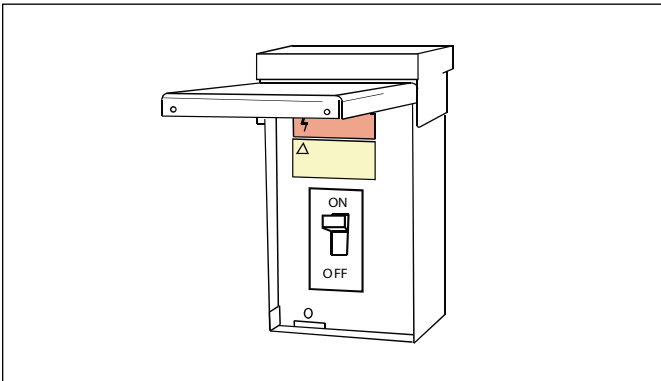

Figure 28



Proceed to Step 6 if IDS Gateway Accessory is not installed.

4. Once power is supplied to the outdoor unit. LEDs on the Gateway will turn on.



Figure 29



A LED sequence may flash on gateway for up to 6 minutes if there is a firmware update.

5. Upon initial unit installation, wait one (1) hour before starting the unit if compressor crankcase heater is used and the outdoor ambient temperature is below 70 °F.

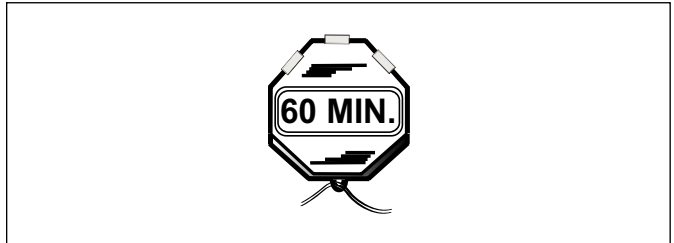

Figure 30

6. Set system thermostat to ON.



Figure 31

12.2 Communication with BCC100/BCC110 (Recommended)

When using Hyper-Link (M1 M2) or PQ communication mode and the system is controlled by a BCC100/BCC110, the homeowner should pair the BCC100/ BCC110 with the outdoor unit via the Bosch EasyAir App for optimal system control.

1. Ensure homeowner adds the BOVB19 outdoor unit and the BCC100/ BCC110 thermostat to their profile on the Bosch EasyAir App.



The heat pump can be accessed by a Homeowner only if the contractor associates it to the homeowner via 'Remote Request' tab.

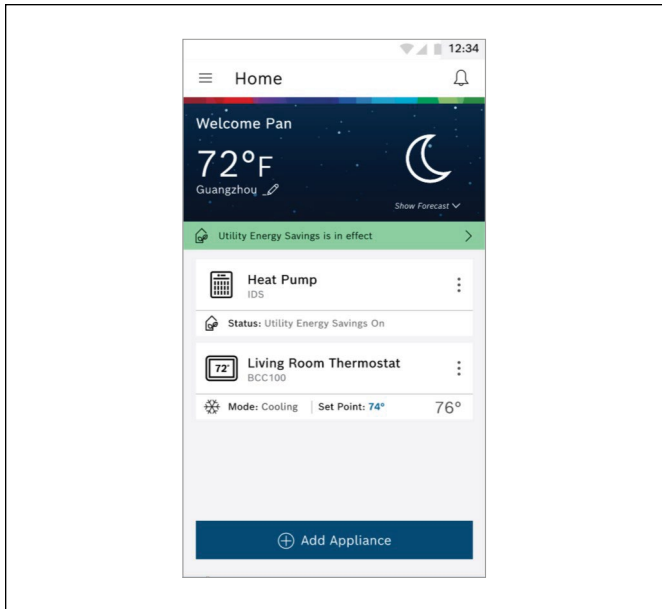

Figure 32

2. Homeowner will find “Appliance Pairing” option in the outdoor unit setting tab.

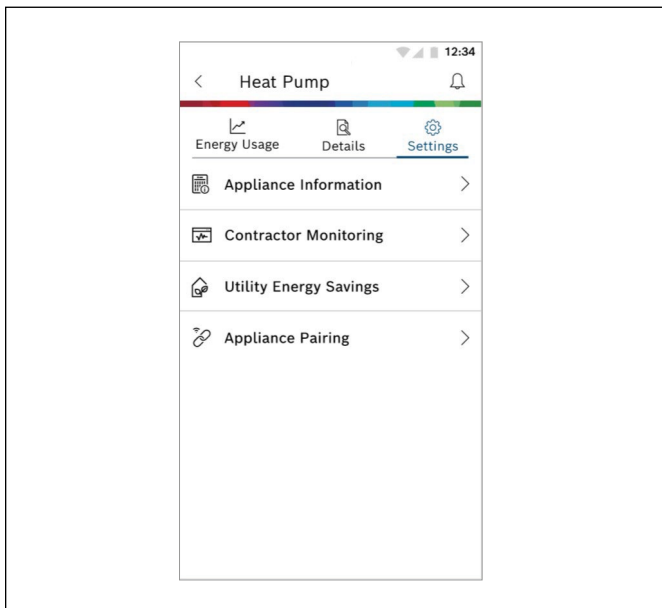

Figure 33

3. Homeowner should click on “Appliance Pairing” and pair the Outdoor Unit with the appropriate BCC100 or BCC110.

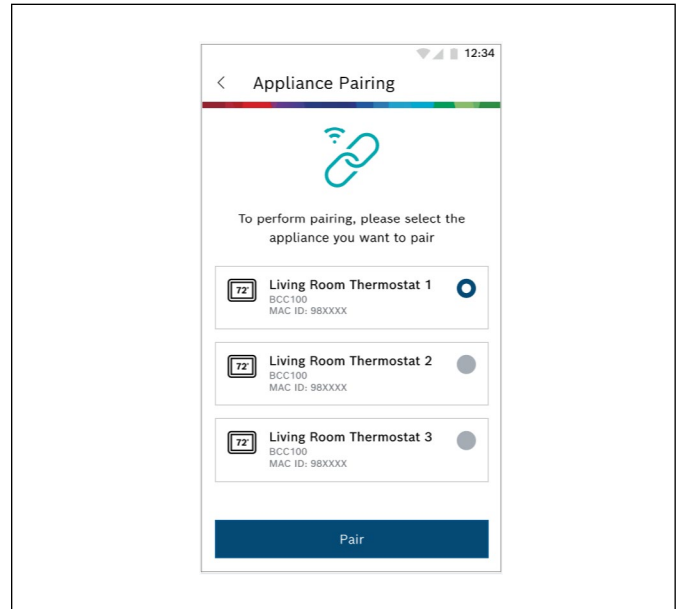

Figure 34



The appropriate thermostat is the one providing the unit with the 24V signals.



For multi-zone applications, multiple thermostats can be paired to the same outdoor unit.

13 System Charge Adjustment



Units come precharged from factory. 3 Ton units with 6-3 lb-oz and 5 Ton units with 10-9 lb-oz. Follow Section "13 System Charge Adjustment" on page 36 for charge adjustments i.e if components have been replaced, or if there is a suspected leak.

13.1 Charging: Weigh-In Method (Recommended)

Weigh-in method is recommended anytime a system charge is being replaced. Weigh-in method can also be used when power is not available to the equipment site or operating conditions (indoor/outdoor temperatures) are not in range to verify with the subcooling charging method.

Heat Pump Model	Refrigerant Charge (lb-oz)
3 Ton	6-3
5 Ton	10-9

Table 25

13.2 Subcooling Charging And Refrigerant Adjustment In Cooling (Above 55°F Outdoor Temp.)

1. Check the outdoor ambient temperatures.

Subcooling (**in cooling mode**) is the only recommended method of charging above 55°F outdoor ambient temperatures.

For outdoor ambient temperatures below 55°F use weigh-in charge method.



It is important to return in the spring or summer to accurately charge the system in the cooling mode when outdoor ambient temperature is above 55°F.

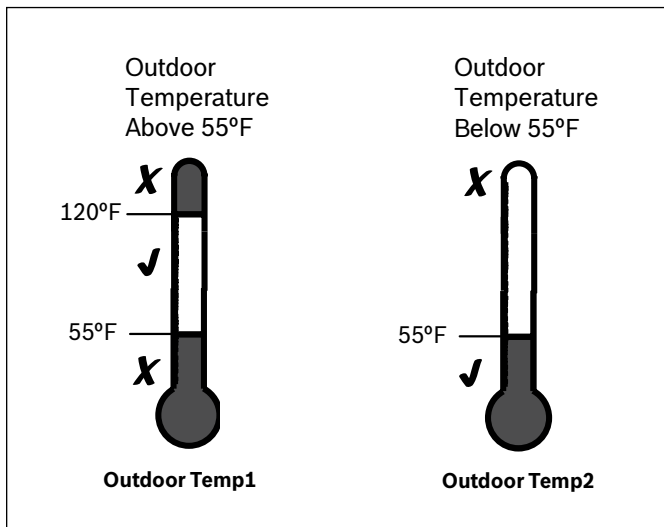

Figure 35

For best results, the indoor temperature should be kept between 70°F and 80°F during the install.

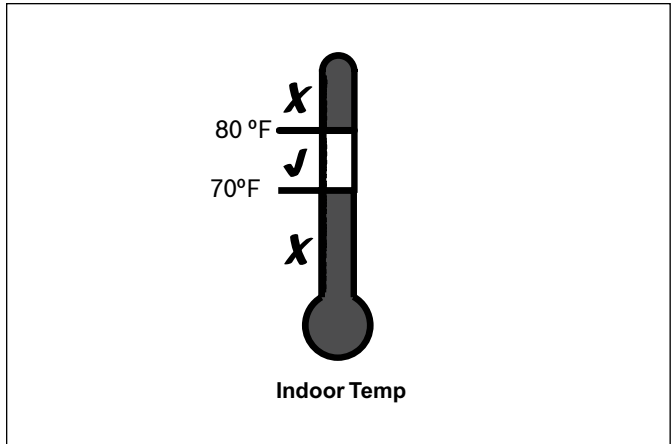

Figure 36

2. Stabilize the system.
3. After **starting the system in cooling mode**, short press "FORCE" button, and a "—" symbol should appear. System may take 10 minutes to ramp up. Operate the system for a minimum of twenty (20) minutes.



After a twenty (20) minute stabilization period operating at 100% capacity, maintain continuous operation while adjusting refrigerant charge. After adjusting, operate system for a minimum of five (5) minutes for stabilization, otherwise repeat step 3.

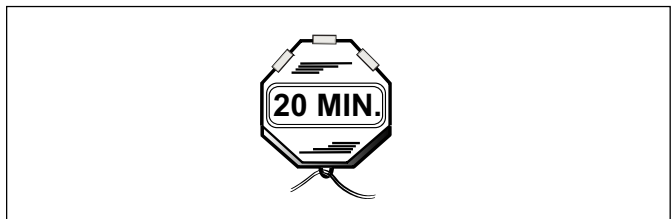

Figure 37

4. Calculate subcooling value on liquid line (According to Table 26)
 - Measured Liquid Line Temp. = ____°F
 - Measured Liquid Line Pressure = ____ PSIG
 - Calculate subcooling value = ____°F

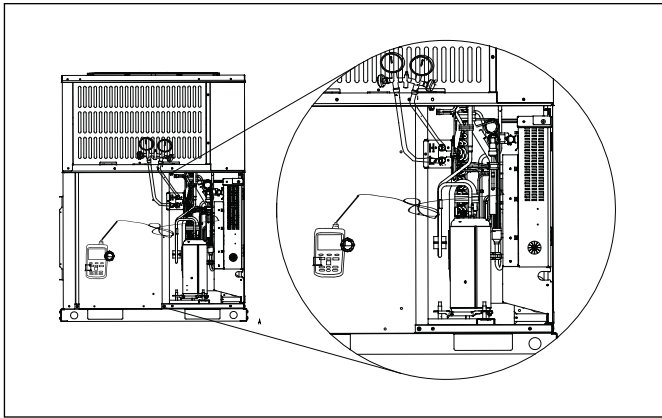

Figure 38



Ensure the temperature sampling position as shown above.

Liquid Temp (°F)	Final Subcooling (°F)							
	6	7	8	9	10	11	12	13
55	164	167	170	172	175	178	181	184
60	178	181	184	187	191	194	197	200
65	194	197	200	203	206	210	213	217
70	210	213	217	220	223	227	230	234
75	227	230	234	238	241	245	249	252
80	245	249	252	256	260	264	268	272
85	264	268	272	276	280	284	288	292
90	284	288	292	297	301	305	309	314
95	305	309	314	318	323	327	332	336
100	327	332	336	341	346	351	355	360
105	351	355	360	365	370	375	380	385
110	375	380	385	390	396	401	406	412
115	401	406	412	417	422	428	433	439
120	428	433	439	445	450	456	462	468
125	456	462	468	474	480	486	492	498

Table 26 R-454B Refrigerant chart - Final Subcooling

Heat Pump Model	Design Subcooling
3 Ton and 5 Ton	12°F ± 4°F

Table 27

- Adjust refrigerant level to attain proper gauge pressure.



Add refrigerant if the subcooling reading from Table 26 is lower than the designed value (Table 27).

- Connect gauges to refrigerant bottle and unit as illustrated (Figure 38 and Figure 39).
- Purge all hoses.
- Open tank.
- Stop adding refrigerant when subcooling matches the charging chart (Table 26) Final Subcooling value.



Recover refrigerant if the subcooling reading from Table 26 is higher than the designed value (Table 27).

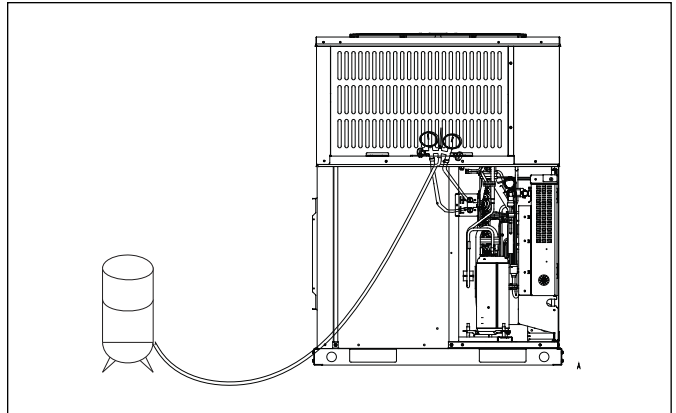

Figure 39

- Stabilize the system.
 - Wait 5 minutes for the system condition to stabilize between adjustments.



When the subcooling matches the chart, the system is properly charged.

- Remove gauges.
 - Replace service port caps to prevent leaks. Tighten finger tight plus an additional 1/6 turn.
- Record System Information for reference (Table 28). Record system pressures and temperatures after charging is complete.



The subcooling also can be calculated by pressing check button after getting T3 and T3L temperatures (refer to Table 33).

Description	Value
Outdoor model number	
Measured Outdoor Ambient	°F
Measured Indoor Ambient	°F
Measured Liquid Line Temp	°F
Measured Suction Line Temp	°F
Liquid Gauge Pressure	PSIG
Suction Gauge Pressure	PSIG

Table 28

14 System Operation and Troubleshooting

14.1 Control Logic Description

- The variable speed system adopts the same 24VAC control as any conventional heat pump.
- The compressor's speed is controlled based on coil pressures monitored by the unit's pressure transducer. To ensure stable and adequate capacity, the compressor speed will modulate relative to evaporator pressure during cooling operation and relative to condensing pressure during heating operation. The target pressure can automatically adjust based on compressor operation so optimal capacity can be achieved. Target pressure can be manually adjusted (SW4) to achieve improved dehumidification and capacity demands.

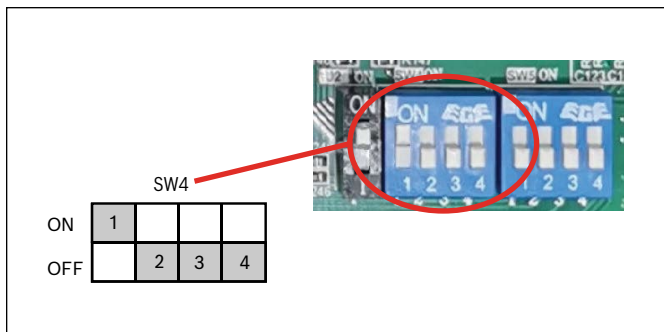

Figure 40

Dip Switch	Position	Description
SW4-1	ON	Must be set at "ON" position
	OFF	Unused
SW4-2	ON	Decelerated cooling/heating
	OFF	Normal cooling/heating*
SW4-3	ON	Unused
	OFF	Must be set at "OFF" position
SW4-4	ON	Accelerated cooling/heating
	OFF	Normal cooling/heating*

Table 29

*Factory Default

- Adaptive capacity function is a "self-learning function" which allows a range of target coil temperatures to adapt for better unit operation and reduced short cycling.
- Accelerated cooling/heating function changes the initial target coil temperature to provide "enhanced comfort" by increasing unit capacity.
- Decelerated cooling/heating function changes the initial target coil temperature to provide "softened comfort" by decreasing the rate of compressor speed change.

14.2 Sensors (Thermistors/Pressure Transducer)

- T1 = Return Air Temperature
 - Indoor Fan Control
- T2 = Indoor Coil Temperature
 - Anti-cold air function in heating mode
- T3 = Outdoor Coil Temperature
 - High/Low temperature protection
 - Outdoor fan control (cooling mode)
 - Defrost control (heating mode)
- T4 = Ambient Temperature
 - Operating condition permission
 - Defrosting condition permission
 - Outdoor fan control (heating mode)
- T5 = Compressor Discharge Temperature
 - High/Low temperature protection
 - Electronic Expansion Valve (EEV) (ODU/heating mode only)
- Th = Compressor Return Temperature
- T3L = Liquid Line Temperature
- TF = Control Board Module Temperature
 - Control Board Overheat Protection
- Pressure transducer
 - Compressor frequency control
 - Electronic Expansion Valve (EEV) control (in both heating and cooling modes)
 - High pressure protection (heating mode)
 - Low pressure protection (cooling mode)

14.3 Defrost Description

- The Demand Defrost Control (DDC) monitors the ODU coil temperature using thermistor (T3). A second thermistor (T4) monitors outdoor ambient temperature. Based on these parameters, as well as accumulative run time and high pressure, the DDC calculates proper initiation of defrost.
- Any one of the below three conditions is required to enter defrost:
 - The calculated temperature difference between the outdoor temperature (T4) and the coil temperature (T3) is called Delta T. After Delta T is achieved and continues for 3 minutes.
 - T4 ≥ 39°F, Delta T = 18°F
 - T4 ≥ 30°F, Delta T = 16°F
 - T4 ≥ 19°F, Delta T = 14°F
 - When T4 < 19°F, T3 < 9°F, accumulative compressor run time ≥ 88 minutes.
 - After “Minimum Run Time” (MRT) is achieved. MRT is based on outdoor ambient temperature (T4), for example:
 - MRT is 4 hours when: T4 < 23°F
 - MRT is 2 hours when: 23°F ≤ T4 < 42°F
 - After the high pressure saturation temperature drops below 82°F for 20 minutes.
- Defrost will terminate once outdoor coil temperature (T3) reaches 64°F for a period of 1 minute or defrost time has exceeded 8 minutes.
- Defrost Termination Settings (SW5) offers different defrost termination options for enhanced defrost for different geographical and outdoor conditions.

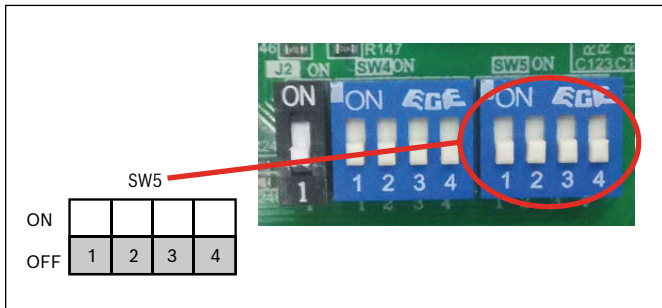

Figure 41

Dip Switch	Position	Description
SW5-1	ON	Enter Defrost - Heating time reduced 10%
	OFF	Normal*
SW5-2	ON	Exit Defrost - Defrosting extended for 120 seconds
	OFF	Normal*
SW5-3	ON	Reserved
	OFF	Must be set at "OFF" Position
SW5-4	ON	Reserved
	OFF	Must be set at "OFF" Position

Table 30

- Manual Defrost:
 - System must have a call for heat and have been operating for a minimum of 8 minutes.
 - Press “Force” button on inverter board for 6 seconds to begin forced defrost.
 - Wait approximately 40 seconds for defrost to initiate.
 - Once defrost initiates, the display will indicate “dF”.
 - Defrost test will terminate automatically, after which the display will indicate running speed.
 - If a second defrost test is required, repeat steps 2-5 after 5 minutes.

14.4 Compressor Crankcase Heater Description

Refrigerant migration during the OFF cycle can result in noisy start-ups, therefore a CrankCase Heater (CCH) is used to minimize refrigerant migration thereby minimizing start-up noise and/or bearing “wash out”. All CCHs must be installed on the lower half of the compressor shell. Its purpose is to warm the compressor during the OFF cycle, driving refrigerant from compressor. After extended shutdown periods in cold weather, it is recommended to allow CCH to be energized for at least 12 hours prior to compressor operation by applying line voltage to heat pump with thermostat OFF.

- CCH operation energizes:
 - First time line voltage is applied and compressor discharge temperature T5 < 54°F.
 - Compressor stops running for 3 hours and compressor discharge temperature T5 < 54°F.
- CCH operation de-energizes:
 - Compressor discharge temperature T5 ≥ 61°F.
 - Compressor start running.

14.5 Reversing Valve Operation

- Reversing valve energizes during heat mode and de-energizes in cool mode. The operation voltage of reversing valve is 220V.



During a heat call on first time operation the unit will run about 1 minute in cooling to build up pressure for reversing valve to change.

14.6 A2L Refrigerant Sensor

The unit comes with a factory installed R454B Refrigerant leakage sensor located behind the evaporator coil and under the return air outlet plenum. Before powering on the unit, verify that the sensor is plugged into the CN26 port on the indoor control board. See the figure below for reference.

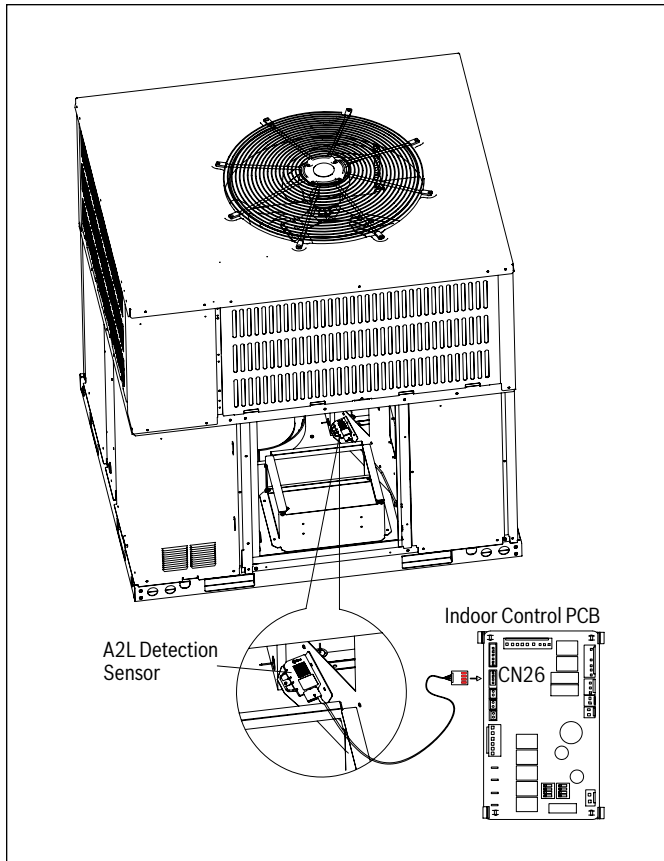

Figure 42

 **CAUTION**

Fire hazard!

Only the factory supplied or specified refrigerant leakage sensor model in the manual shall be used.

The R454B refrigerant leakage sensor must be used to activate the refrigerant shut-off device, the alarm device, incorporated circulation airflow or other emergency controls, which shall give an electrical signal at a predetermined alarm setpoint in response to leaked refrigerant.

The location of leakage sensors shall be chosen in relation to the different installation scenarios. Please refer to the indoor unit installation manual for specific requirements.

The installation of the refrigerant leakage sensor shall allow access for checking, repair or replacement by an authorized person.

The refrigerant leakage sensor shall be installed so its function can be verified easily.

The refrigerant leakage sensor shall be protected to prevent tampering or unauthorized resetting of the pre-set value.

To be effective, the refrigerant leakage sensor must be electrically powered at all times after installation, other than when servicing.

If the refrigerant leakage sensor detects a refrigerant leak, the fan will be turned on to the maximum, the compressor will stop running. Immediately leave the leak area and notify a professional for handling.

The service life of the refrigerant sensor is 15 years, and it should be replaced after the service life.

 **WARNING**

Fire, explosion, personal injury!

LEAK DETECTION SYSTEM installed on indoor unit. Unit must be powered except for service.

NOTICE

Product damage!

R454B refrigerant leakage sensor is designed for the indoor unit. The operation of fan can be initiated by the R454B refrigerant sensor, which meets the incorporated circulation airflow requirements.

The allowed maximum refrigerant charge (Mmax) and the required minimum room area (Amin) can be determined according to Table 11 and Table 12 through Table 14.

14.7 Protection Functions

- Outdoor coil temperature protection (T3)
 - i. If $T3 > 147^{\circ}\text{F}$, compressor is de-energized.
 - ii. If $T3 < 129^{\circ}\text{F}$, compressor is energized.
- Ambient temperature protection (T4)
 - i. If $23^{\circ}\text{F} \leq T4 < 125^{\circ}\text{F}$, unit can operate in cooling.
 - ii. If $-4^{\circ}\text{F} \leq T4 < 86^{\circ}\text{F}$, unit can operate in heating.
 - iii. If $T4 < -4^{\circ}\text{F}$, heat pump will provide 24V control to indoor unit energizing electric heat (if installed).



See Product Specification for extended performance data.

- Discharge Temperature (DT) protection (T5)
 - i. If $DT > 230^{\circ}\text{F}$ during cooling mode, the compressor will stop.
 - ii. If $DT < 185^{\circ}\text{F}$ during cooling mode, the compressor will restart.
 - iii. If $DT > 230^{\circ}\text{F}$ during heating mode, the compressor will stop.
 - iv. If $DT < 185^{\circ}\text{F}$ during heating mode, the compressor will restart.
- High Pressure (HP) protection (mechanical open/close pressure switch)
 - i. High Pressure Switch opens at $P > 580$ PSIG, the compressor and outdoor fan stop.
 - ii. High Pressure Switch closes at $P < 435$ PSIG, the compressor and outdoor fan restart.
- Low Pressure (LP) protection
 - i. If Low Pressure < 43.5 PSI for 5 minutes during cooling mode, the compressor and outdoor fan will stop. The system will attempt to run again after 3 minutes.
- Module (inverter) protection (TF)
 - i. If $TF > 203^{\circ}\text{F}$, the compressor and outdoor fan will stop.
 - ii. If $TF < 176^{\circ}\text{F}$, the compressor and outdoor fan will restart.

14.8 Fault Code Table

Code	Fault Description (Sensor)
AtL	Ambient Temperature Limited(T4)
b1	Temperature sensor fault in indoor unit (T1)
b2	Temperature sensor fault in indoor unit (T2)
b3	R454B refrigerant sensor hardware fault in indoor unit
b4	R454B refrigerant sensor communication fault in indoor unit
b5	Communication fault between indoor unit and outdoor unit
b7	R454B refrigerant leakage protection in indoor unit
b8	R454B refrigerant sensor over service life in indoor unit
b9*	Dip Switch SW7-2 does not match R454B refrigerant sensor configuration
C3	The coil sensor is unplugged in cooling (T3)
E41	Temperature sensor fault (T3)
E42	Temperature sensor fault (T3L)
E43	Temperature sensor fault (T4)
E44	Temperature sensor fault (T5)
E45	Temperature sensor fault (Th)
E51	Outdoor unit high/low input voltage protection
E52	Outdoor unit high/low DC bus voltage protection
E7	Compressor discharge sensor is unplugged (T5)
E81	EEVA solenoid coil fault
EA	Control program does not match drive program in outdoor unit
Eb	Dip Switch SW4-1 set incorrectly
F1	High pressure switch fault (HPS)
F2*	5 times (P21) protection in 100 minutes, system lockout
F41	Pressure sensor fault
H01	Drive chip Communication fault in outdoor unit
J00-JCF	Compressor driver fault
n00-nCF	Outdoor fan motor driver fault
o37	Lack of refrigerant
P0	Compressor IPM temperature protection
P1	High pressure switch protection (HPS)
P11	High pressure protection in cooling/heating (Pc)
P21	Low pressure protection in cooling/heating (Pe)
P31	Outdoor unit over current protection
P32	Compressor over current protection
P4	High compressor discharge temperature protection (T5)
P5	Condensor coil temperature protection in cooling (T3)
PF	Evaporator freezing protection
PH	Low discharge superheat protection

Table 31

* Fault requires hard restart

14.9 System Protection Status Codes

Code	Description
888	Running indication under T3 limited condition
888	Forced operation mode
888	Running indication under high pressure
888	Running indication under low pressure
888	Running indication under return oil mode
888	Running indication under current limited condition
888	Running indication under T5 limited condition
888	Running indication under COMP. IPM Temp. limited condition
888	Running indication under compressor ratio limited condition
888	Running indication under low voltage limited condition
888	Running indication under defrost mode

Table 32

** If the first digit shown on the control board LED is one of the following protection codes (followed by two numerical digits which show the current compressor frequency in Hz), the unit will continue to run but in a limited condition. The only exception is when the system is in defrost mode, which only displays "dF" (without any numerical digits following).*

14.10 Parameter Point Check Table

- To display system parameters, press the “Check” button to index through the series of parameters available. The first time you press the “Check” button, it will display the sequence, and after 1 second it will display the value of the parameter. If you press the “Check” button again, it will display the next sequence. Refer to Figure 43 and Figure 44 for check button location on the control board.
- Normal Status, last two digits will display under the following conditions
 - Unit not operating (Standby Mode); “outdoor ambient temperature”.
 - Unit operating; displays “compressor operating frequency”.
- After 20 seconds on same parameter, the display will revert back to normal status.
- If a system protection is active, first digit will display “status code”.

No.	Point check content	Example	Remark
0	Outdoor unit capacity: H5=Heat pump 5 ton	RH5	H5=Packaged Heat Pump 5 ton
1	Outdoor unit mode: 0-standby, 2-cooling, 3-heating	2	0 standby, 2 cooling, 3 heating
2	Outdoor unit set compressor speed	56	Hz
3	System last fault code	E4	
4	T3: outdoor coil temp.(°F)	108	°F
5	T3L: outdoor coil outlet temp.(°F)	102	°F
6	T4: outdoor ambient temp.(°F)	95	°F
7	T5: compressor discharge temp.(°F)	140	°F
8	Th: compressor suction temp.(°F)	55	°F
9	Compressor IPM temp.(°F)	120	°F
10	Pe: evaporating pressure(psig)	130	psig
11	Pc: condensing pressure(psig)	320	psig
12	Tes: target evaporating temp.(°F) (only for cooling mode)	43	°F
13	Te: evaporating temp.(°F)	43	°F
14	Tcs: target condensing temp.(°F)(only for heating mode)	106	°F
15	Tc: condensing temp.(°F)	106	°F
16	Target value of the compressor discharge superheat(°F) (only for heating mode)	36	°F
17	Compressor discharge superheat (°F)	36	°F
18	Compressor Suction superheat (°F)	10	°F
19	Openings of EEV(P)	200	0-480P
20	Fan speed stage	8	(0-10)
21	Outdoor unit fan current(A)	1	A
22	Compressor current(A)	10	A
23	Outdoor unit input current(A)	10	A
24	Outdoor unit input voltage(V)	230	V
25	Outdoor unit DC bus voltage(V)	380	V
26	Outdoor unit power(*0.1kW)	200	Outdoor unit * 0.1 kW
27	Continuous running time of the compressor(min)	35	minutes/0-999/Maintain at maximum
28	Outdoor unit main control software version	11	
29	Indoor unit Heat Kit Staging	1	0~3
30	T1: indoor unit return air temp. (°F)	80	°F
31	T2: indoor unit coil temp.(°F)	55	°F
32	Indoor unit software version	11	
33	Reserved	--	--
34	Reserved	--	--
35	Remark“--”	--	--

Table 33

14.11 Control Board Overviews

Outdoor Unit Control Board for 3 Ton Model

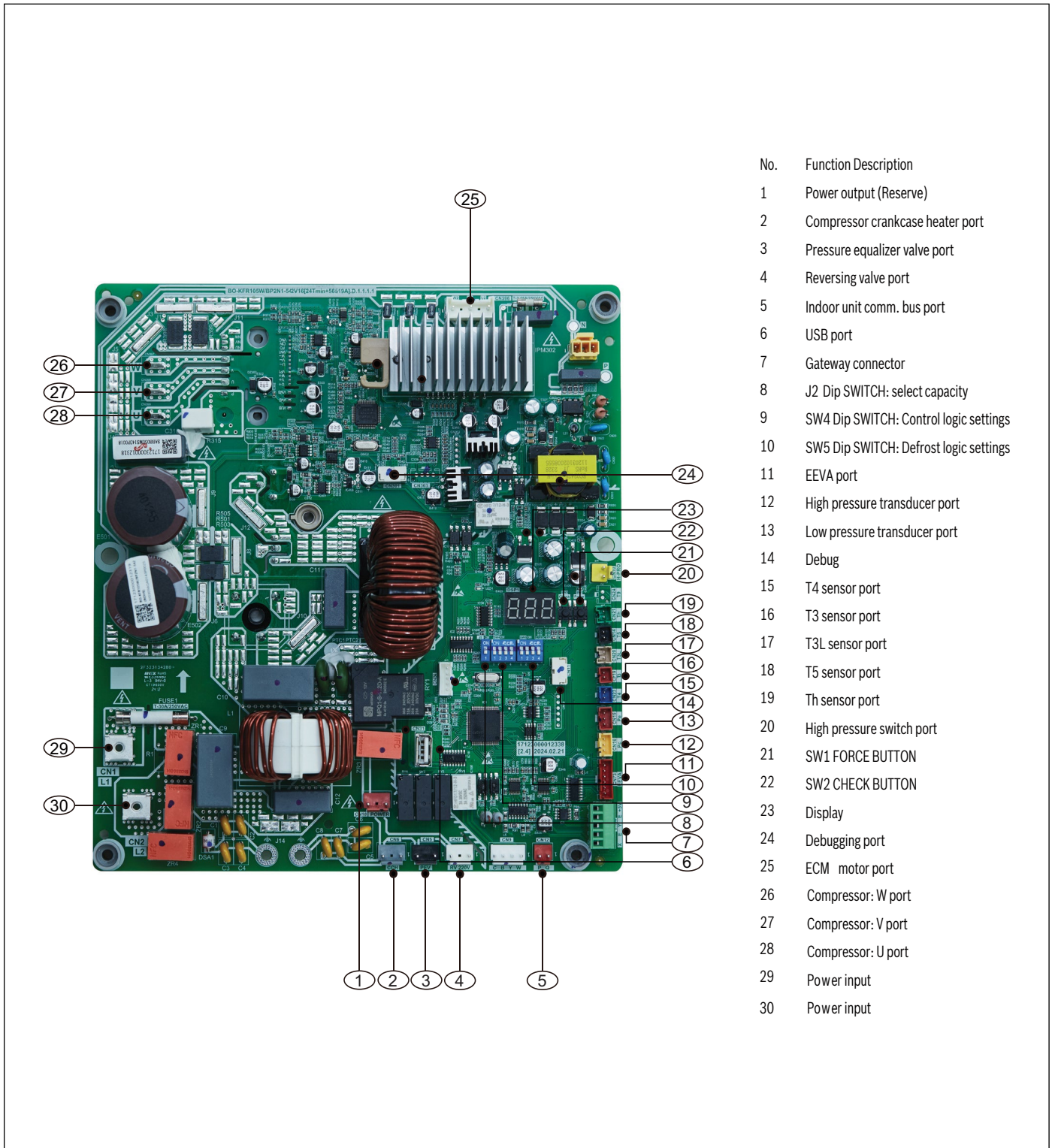

- | No. | Function Description |
|-----|--|
| 1 | Power output (Reserve) |
| 2 | Compressor crankcase heater port |
| 3 | Pressure equalizer valve port |
| 4 | Reversing valve port |
| 5 | Indoor unit comm. bus port |
| 6 | USB port |
| 7 | Gateway connector |
| 8 | J2 Dip SWITCH: select capacity |
| 9 | SW4 Dip SWITCH: Control logic settings |
| 10 | SW5 Dip SWITCH: Defrost logic settings |
| 11 | EEVA port |
| 12 | High pressure transducer port |
| 13 | Low pressure transducer port |
| 14 | Debug |
| 15 | T4 sensor port |
| 16 | T3 sensor port |
| 17 | T3L sensor port |
| 18 | T5 sensor port |
| 19 | Th sensor port |
| 20 | High pressure switch port |
| 21 | SW1 FORCE BUTTON |
| 22 | SW2 CHECK BUTTON |
| 23 | Display |
| 24 | Debugging port |
| 25 | ECM motor port |
| 26 | Compressor: W port |
| 27 | Compressor: V port |
| 28 | Compressor: U port |
| 29 | Power input |
| 30 | Power input |

Figure 43

Outdoor Unit Control Board for 5 Ton Model

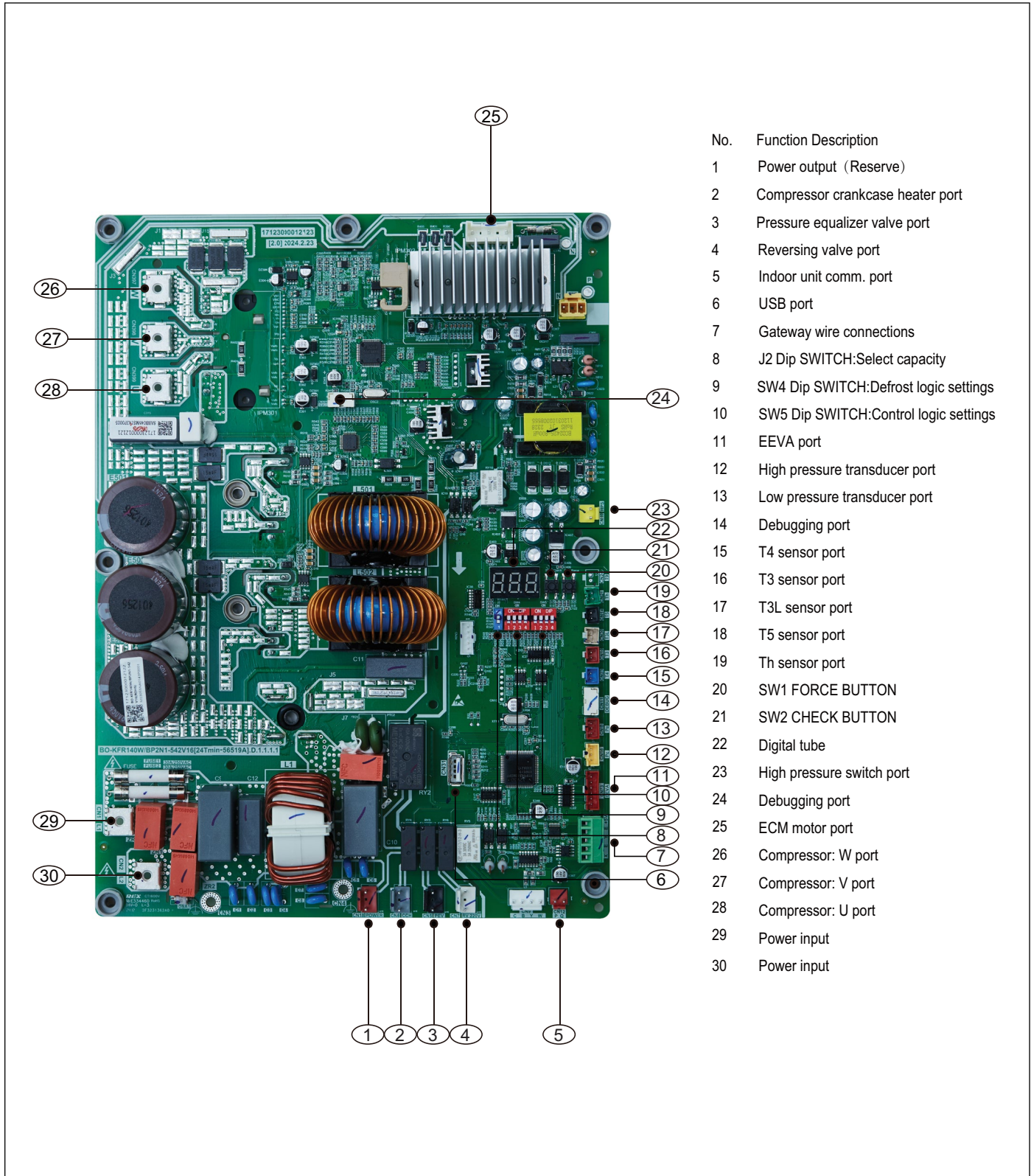

- | No. | Function Description |
|-----|---------------------------------------|
| 1 | Power output (Reserve) |
| 2 | Compressor crankcase heater port |
| 3 | Pressure equalizer valve port |
| 4 | Reversing valve port |
| 5 | Indoor unit comm. port |
| 6 | USB port |
| 7 | Gateway wire connections |
| 8 | J2 Dip SWITCH:Select capacity |
| 9 | SW4 Dip SWITCH:Defrost logic settings |
| 10 | SW5 Dip SWITCH:Control logic settings |
| 11 | EEVA port |
| 12 | High pressure transducer port |
| 13 | Low pressure transducer port |
| 14 | Debugging port |
| 15 | T4 sensor port |
| 16 | T3 sensor port |
| 17 | T3L sensor port |
| 18 | T5 sensor port |
| 19 | Th sensor port |
| 20 | SW1 FORCE BUTTON |
| 21 | SW2 CHECK BUTTON |
| 22 | Digital tube |
| 23 | High pressure switch port |
| 24 | Debugging port |
| 25 | ECM motor port |
| 26 | Compressor: W port |
| 27 | Compressor: V port |
| 28 | Compressor: U port |
| 29 | Power input |
| 30 | Power input |

Figure 44

Indoor Unit Control Board

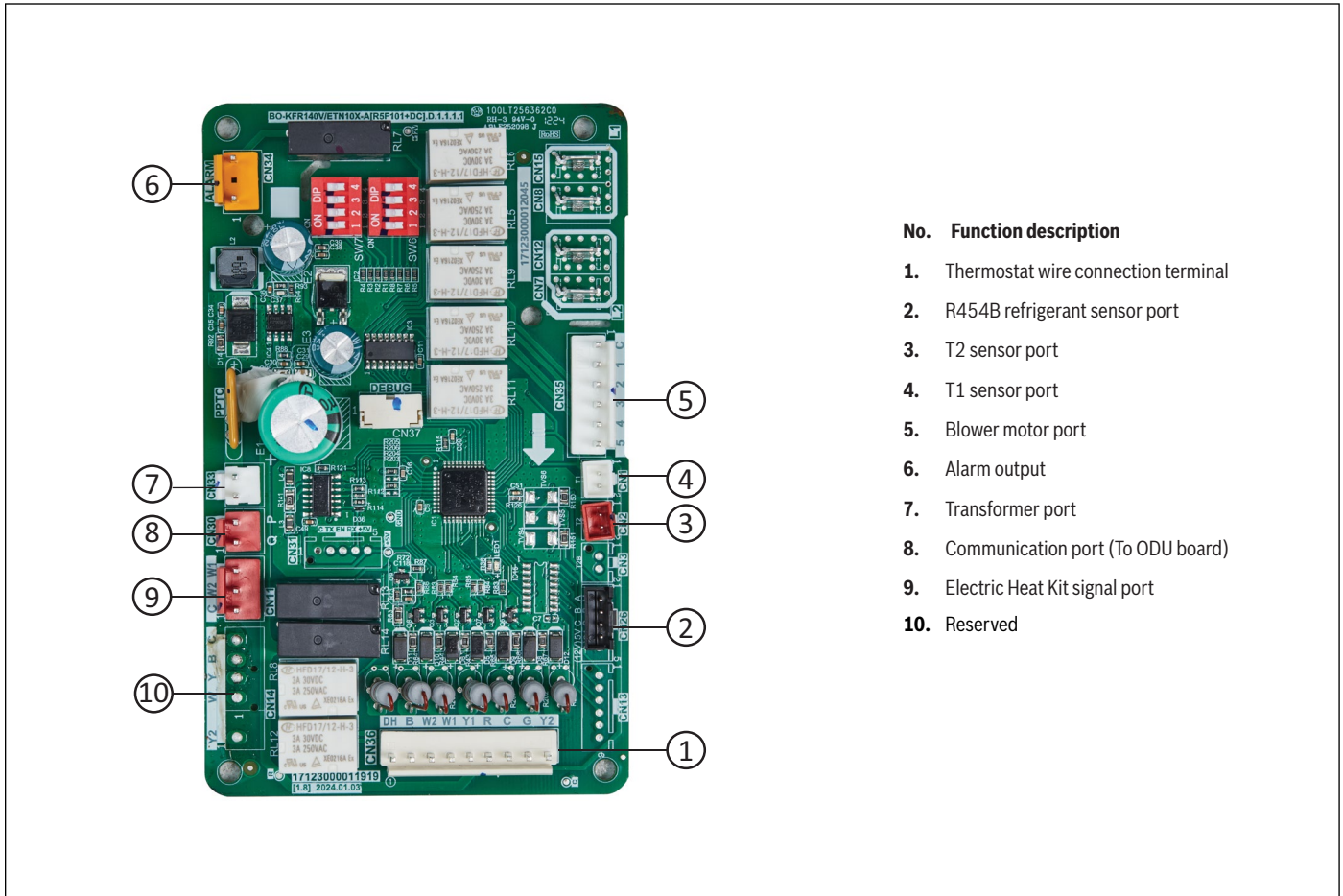

No. Function description

- 1. Thermostat wire connection terminal
- 2. R454B refrigerant sensor port
- 3. T2 sensor port
- 4. T1 sensor port
- 5. Blower motor port
- 6. Alarm output
- 7. Transformer port
- 8. Communication port (To ODU board)
- 9. Electric Heat Kit signal port
- 10. Reserved

Figure 45

14.12 Error Code Troubleshooting

WARNING

Hazardous voltage!

When measuring resistance, make sure the unit is powered off and wait 3 min before taking measurement.

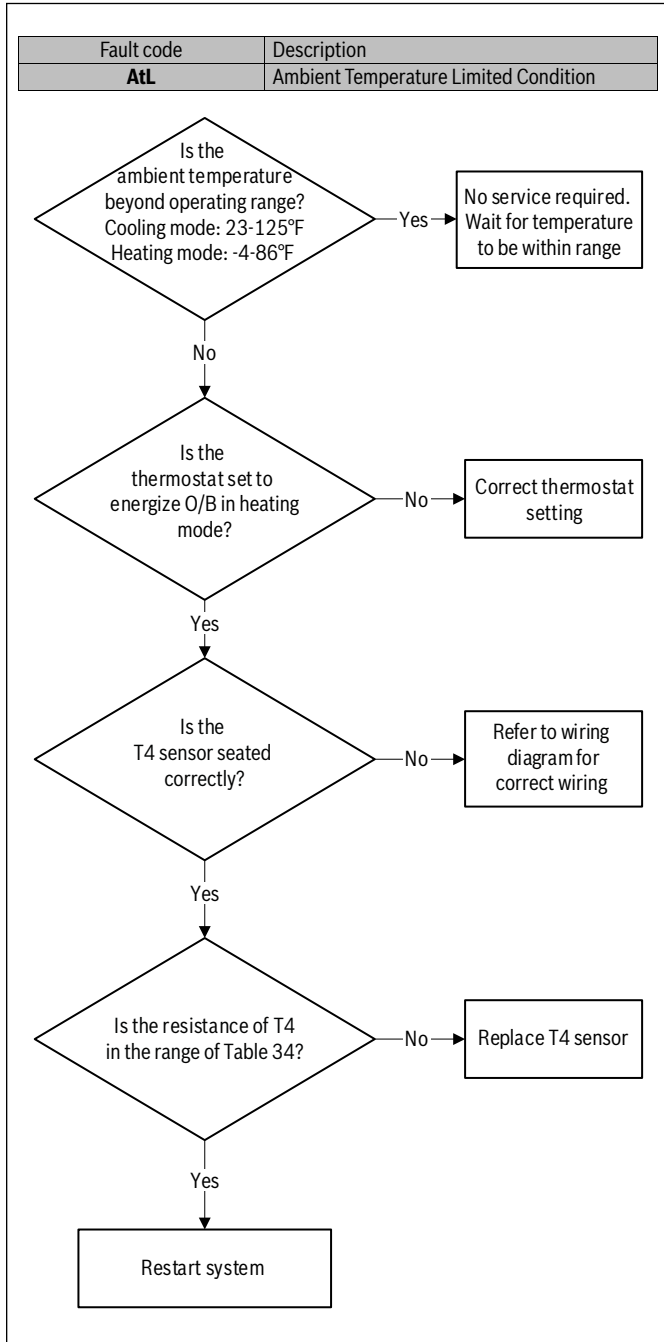

Figure 46

WARNING

Hazardous voltage!

When measuring resistance, make sure the unit is powered off and wait 3 min before taking measurement.

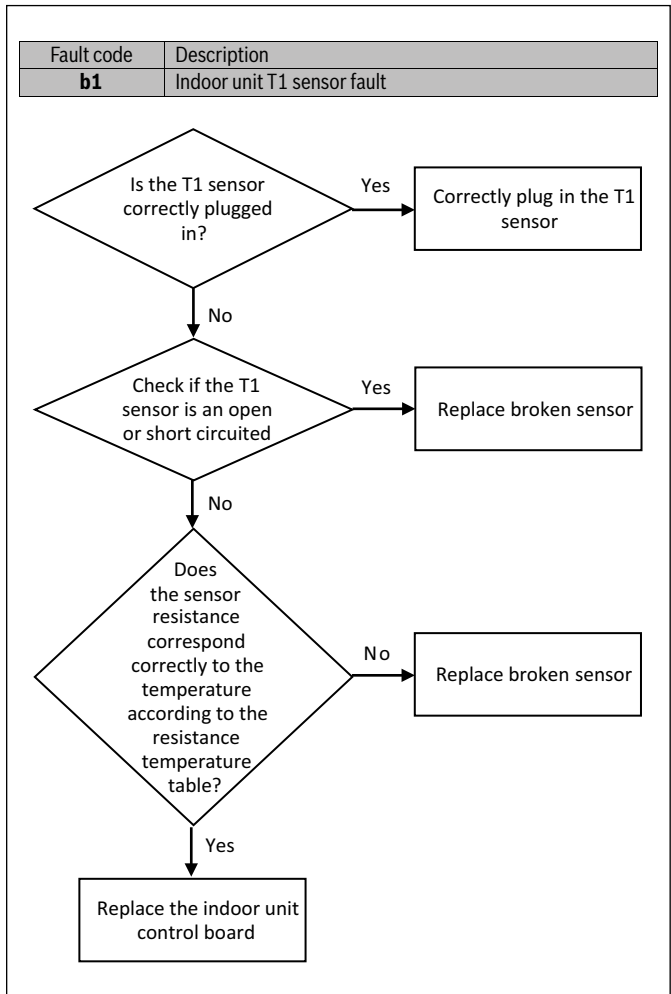

Figure 47

WARNING

Hazardous voltage!

When measuring resistance, make sure the unit is powered off and wait 3 min before taking measurement.

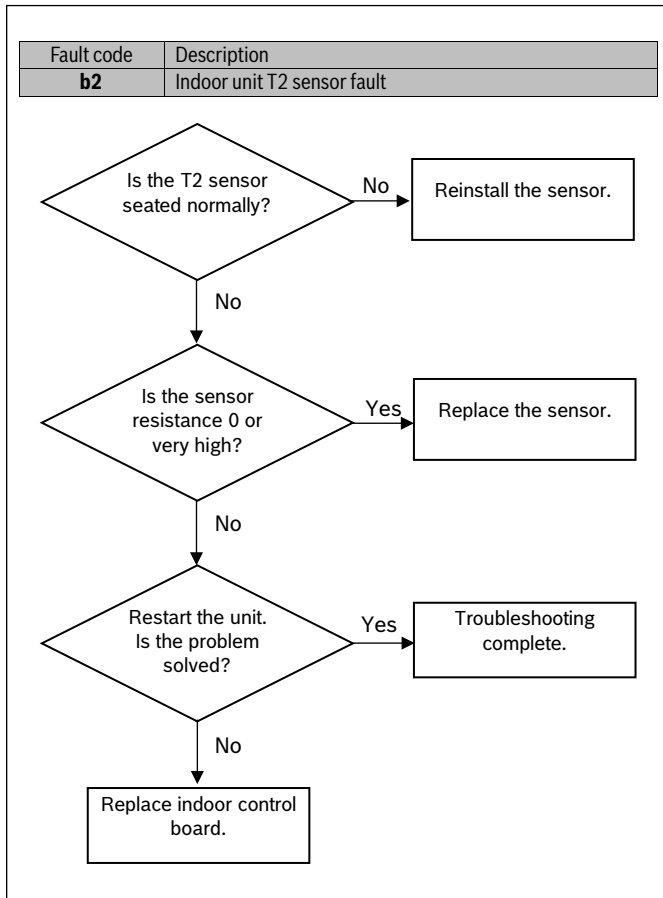

Figure 48

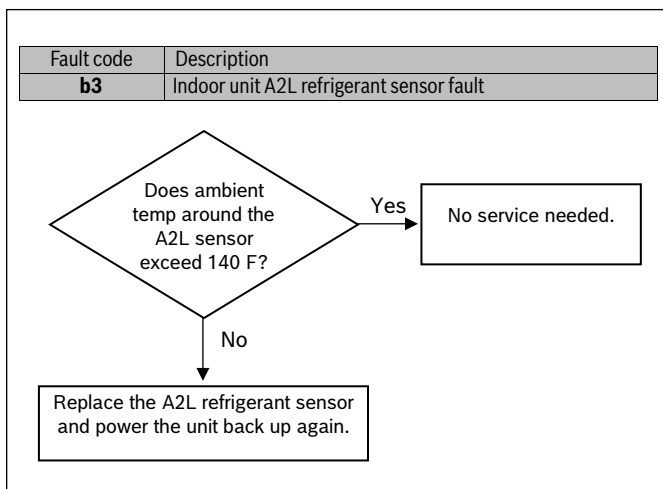

Figure 49

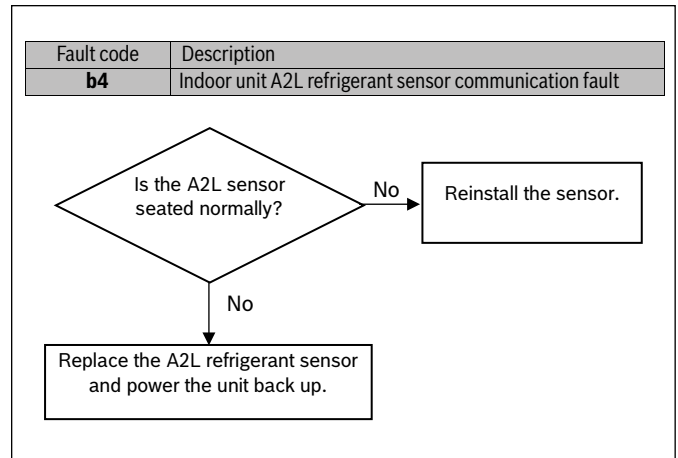

Figure 50

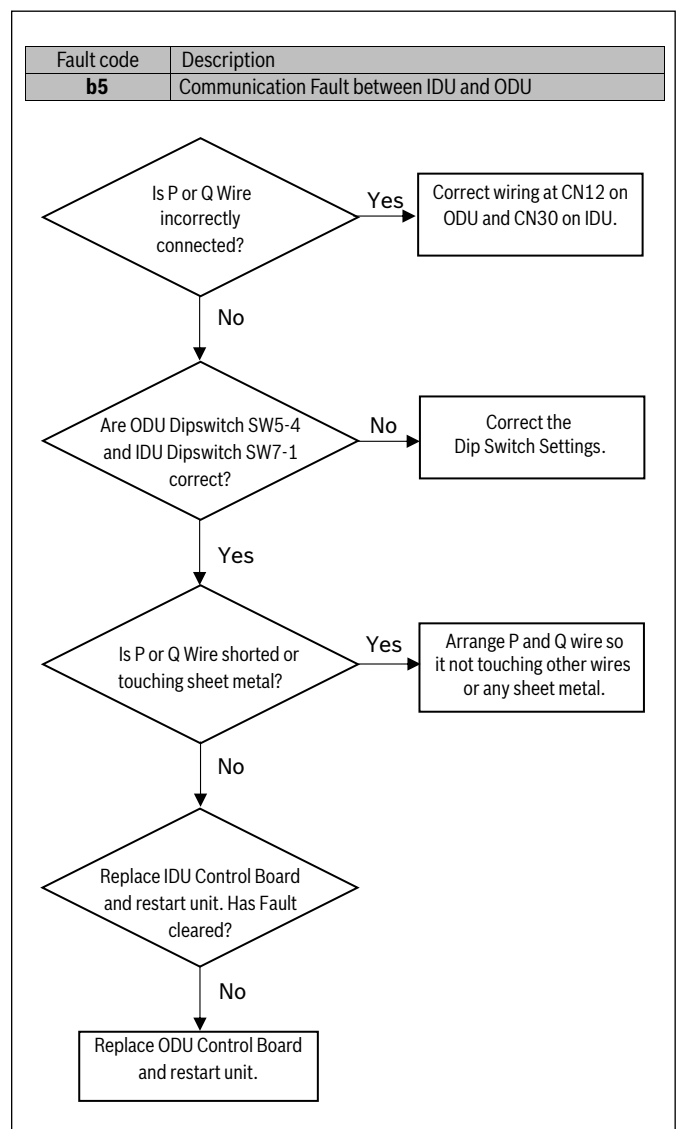

Figure 51

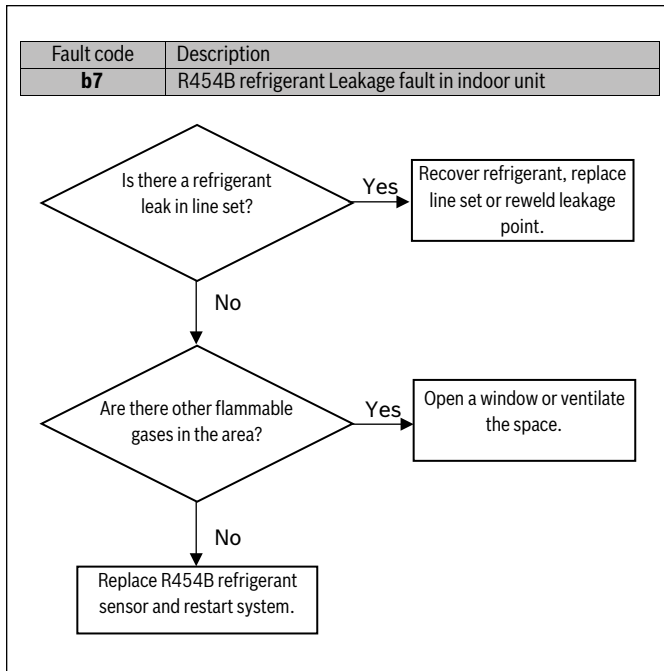

Figure 52

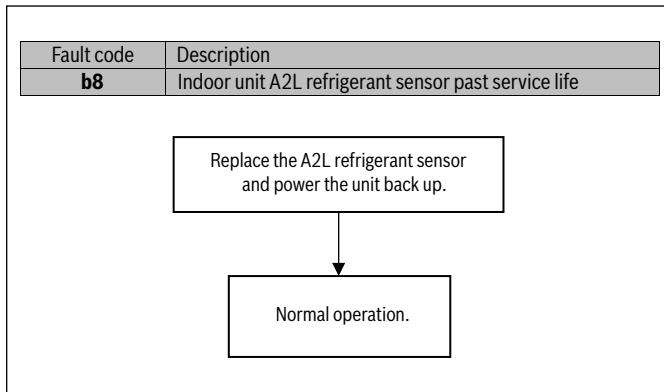

Figure 53

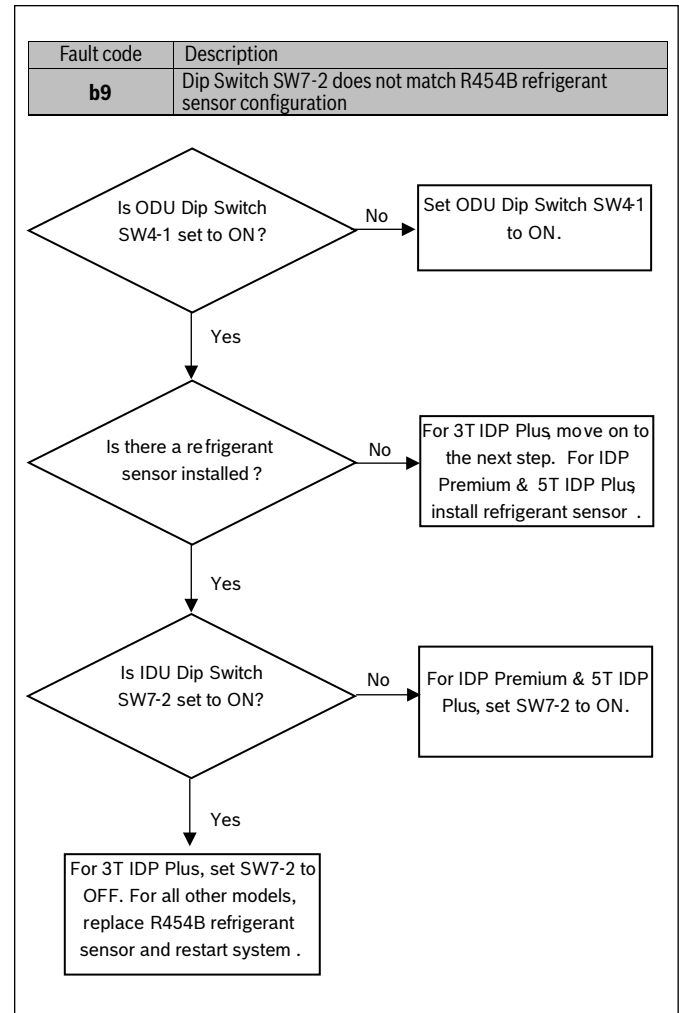

Figure 54

WARNING

Hazardous voltage!
When measuring resistance , make sure the unit is powered off and wait 3 min before taking measurement.

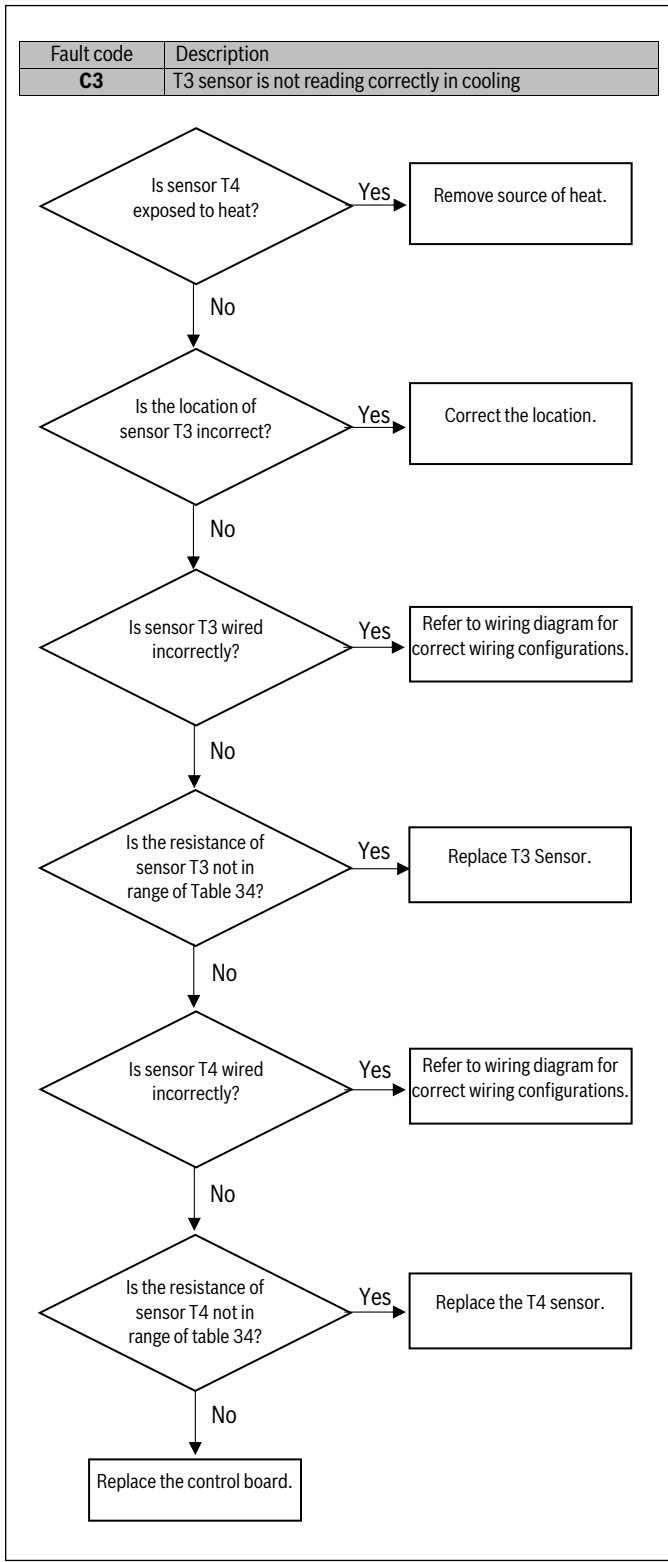

Figure 55

WARNING

Hazardous voltage!
When measuring resistance , make sure the unit is powered off and wait 3 min before taking measurement.

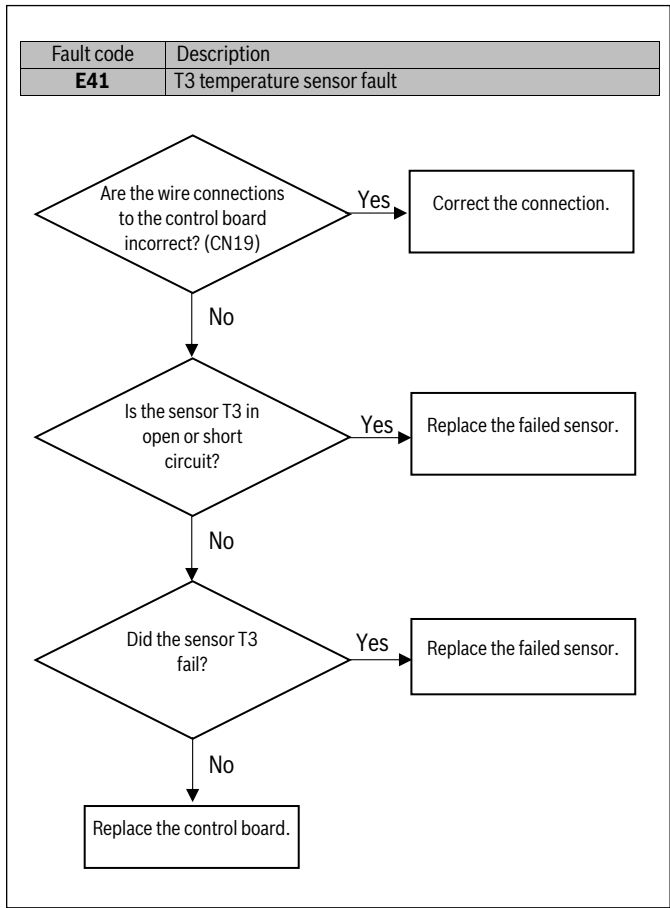

Figure 56

WARNING

Hazardous voltage!

When measuring resistance , make sure the unit is powered off and wait 3 min before taking measurement.

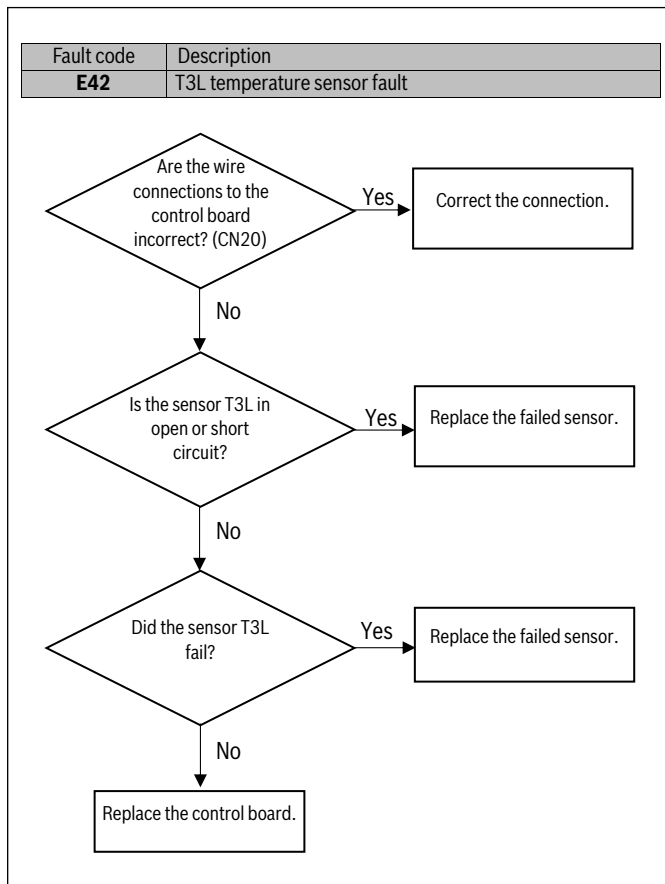

Figure 57

WARNING

Hazardous voltage!

When measuring resistance , make sure the unit is powered off and wait 3 min before taking measurement.

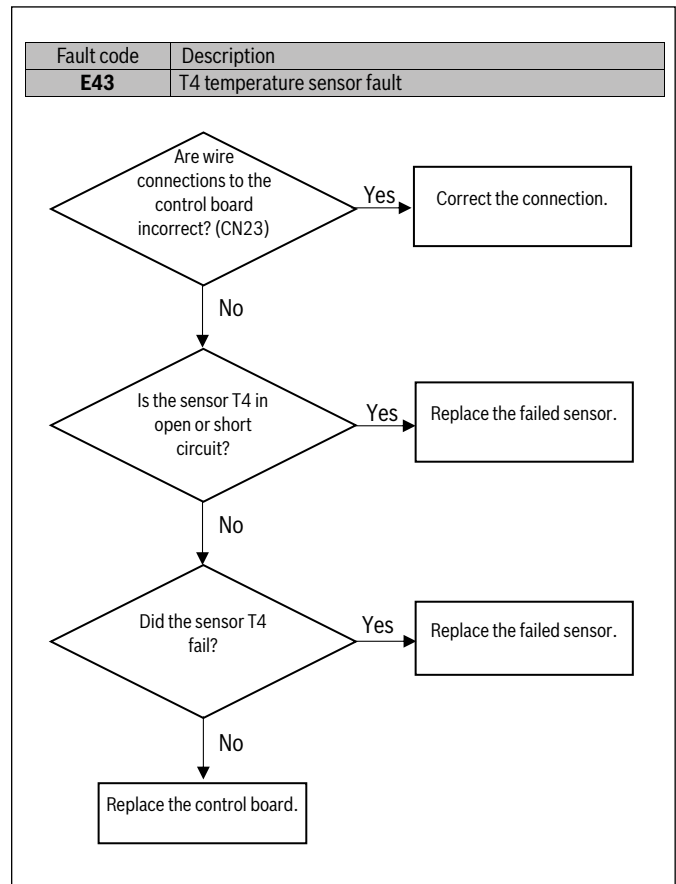

Figure 58

WARNING
Hazardous voltage!
 When measuring resistance , make sure the unit is powered off and wait 3 min before taking measurement.

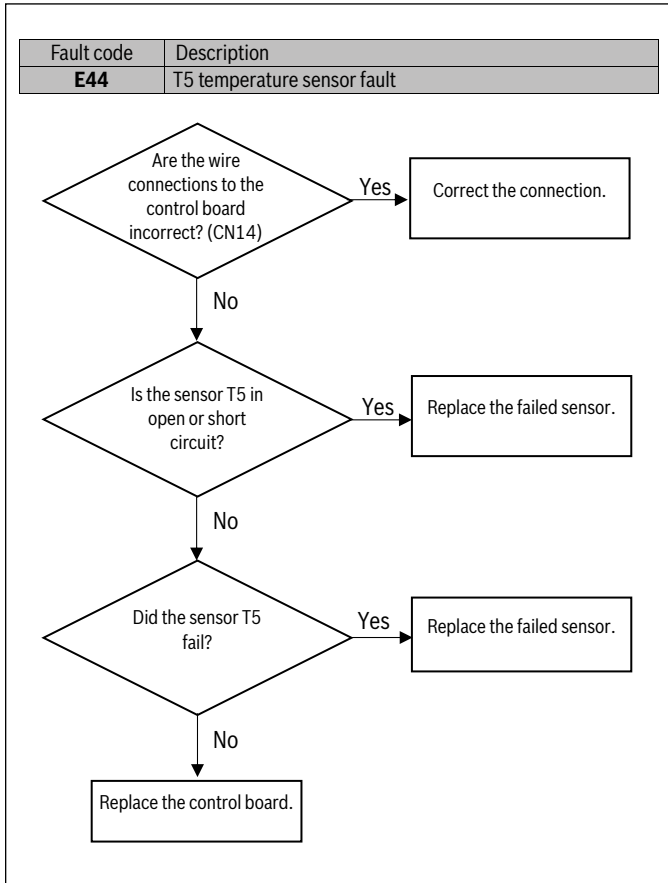

Figure 59

WARNING
Hazardous voltage!
 When measuring resistance , make sure the unit is powered off and wait 3 min before taking measurement.

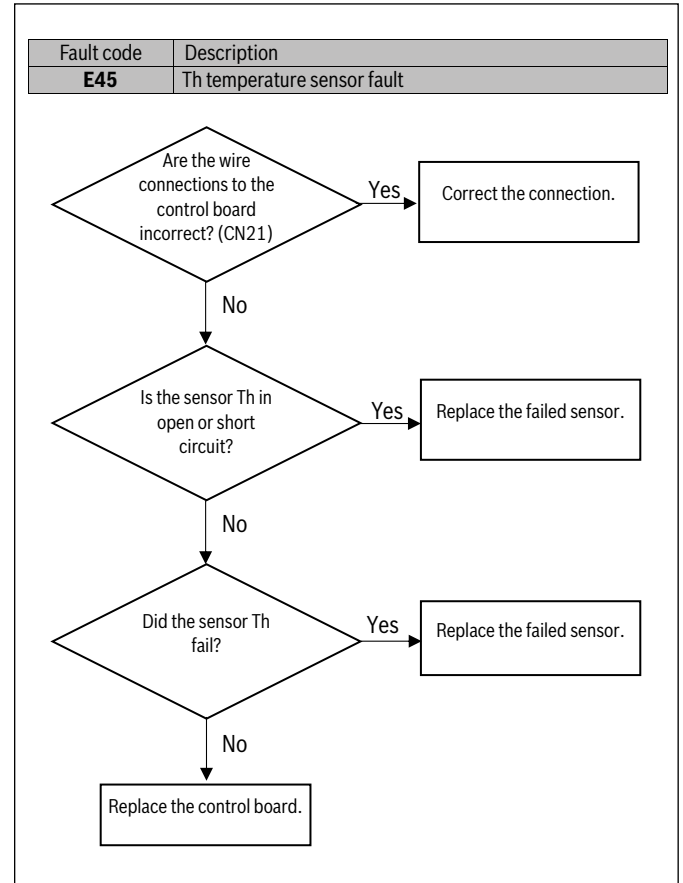

Figure 60

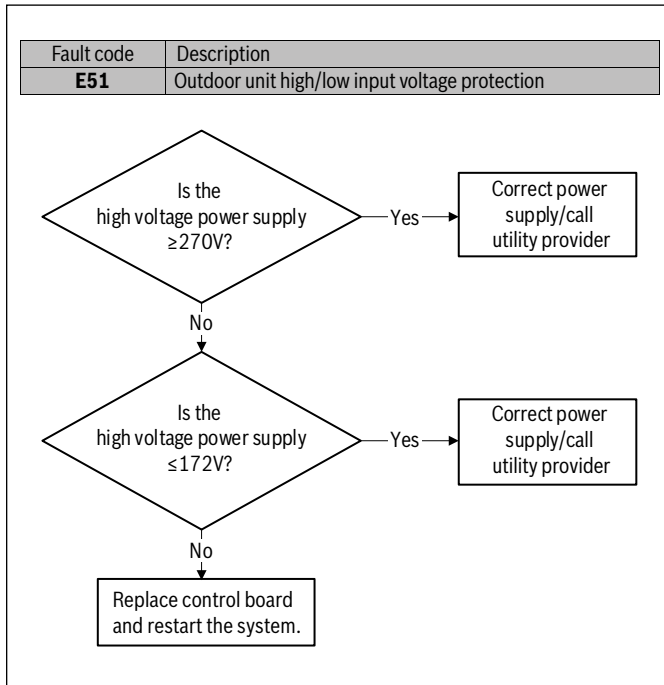

Figure 61

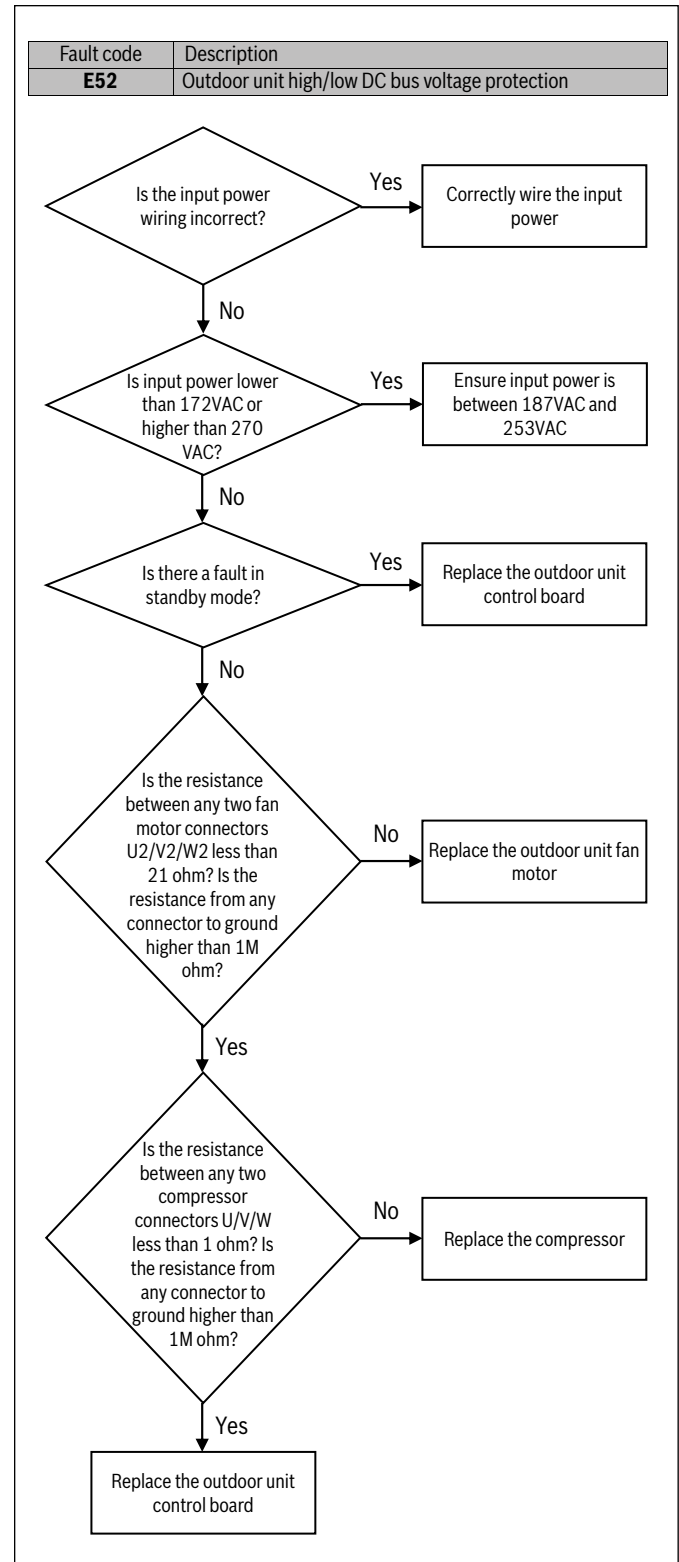

Figure 62

WARNING

Hazardous voltage!

When measuring resistance, make sure the unit is powered off and wait 3 min before taking measurement.

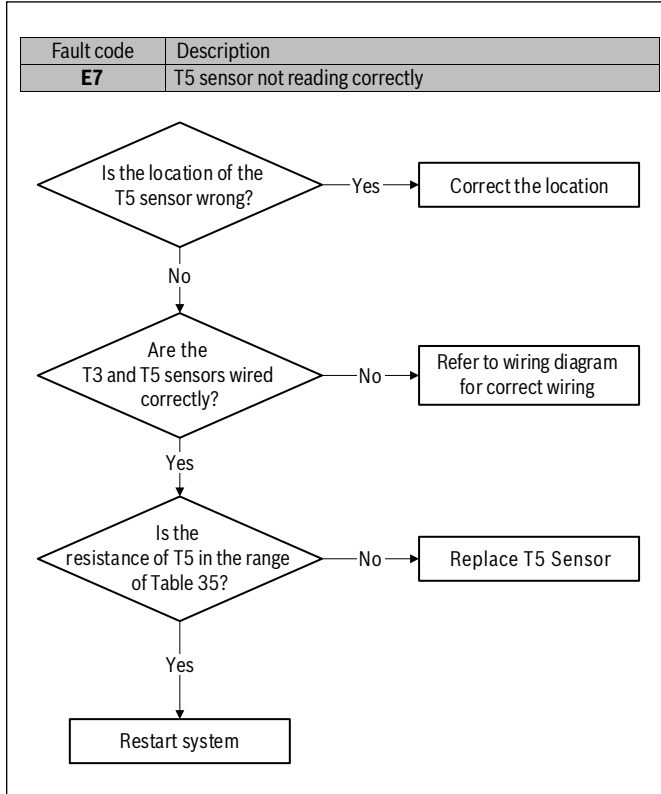

Figure 63

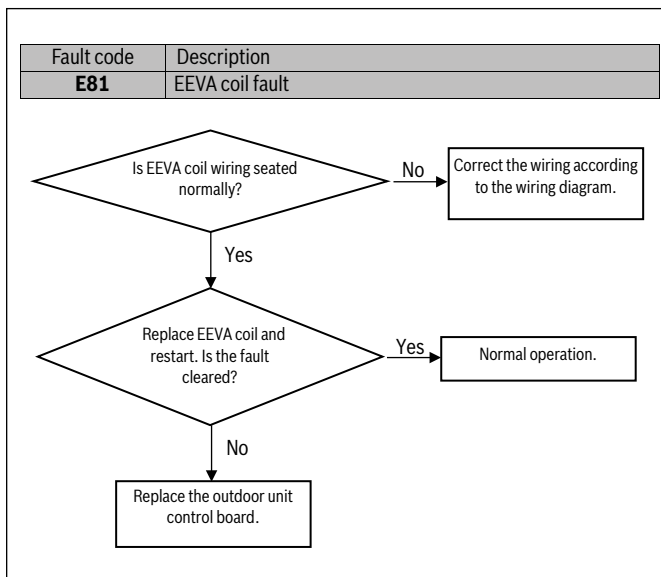

Figure 64

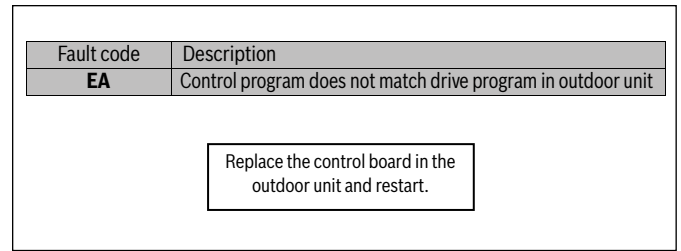

Figure 65

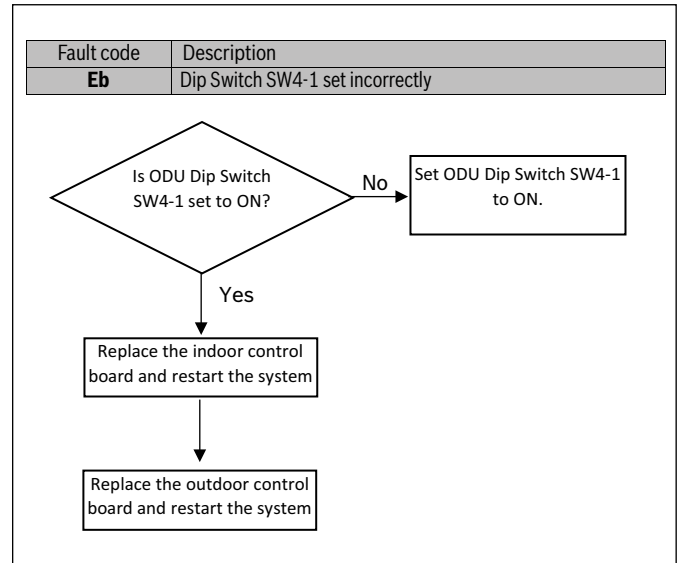

Figure 66

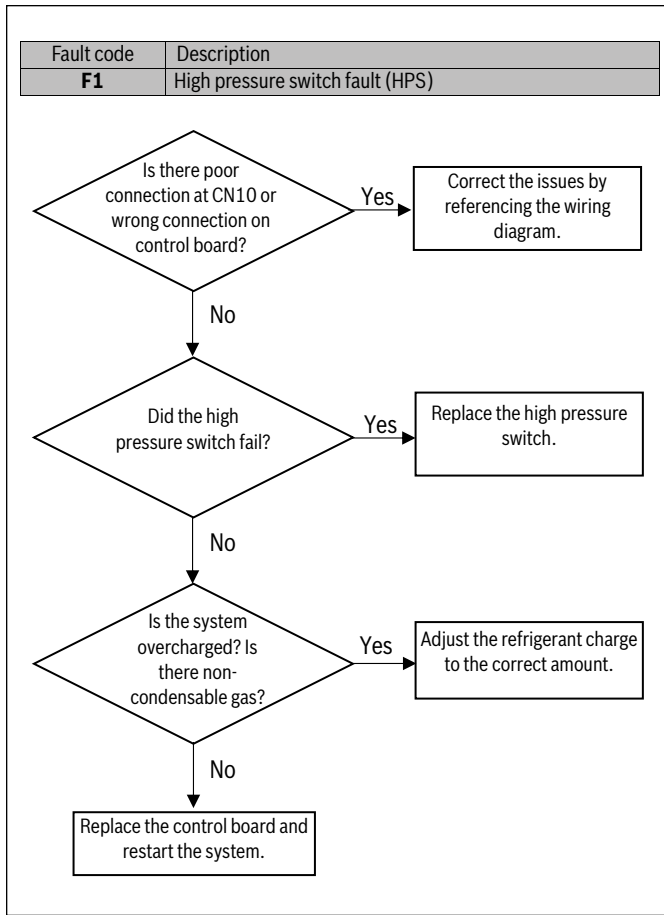

Figure 67

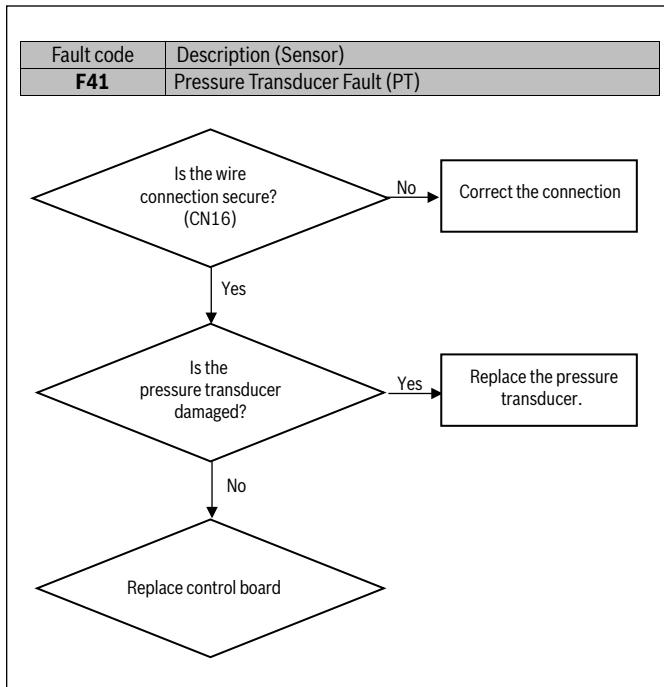

Figure 68

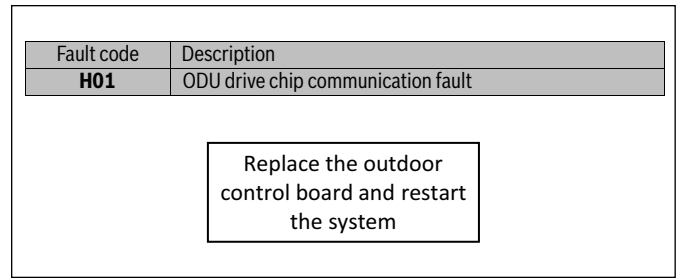

Figure 69

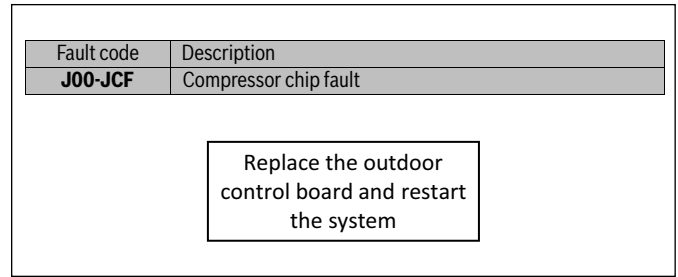

Figure 70

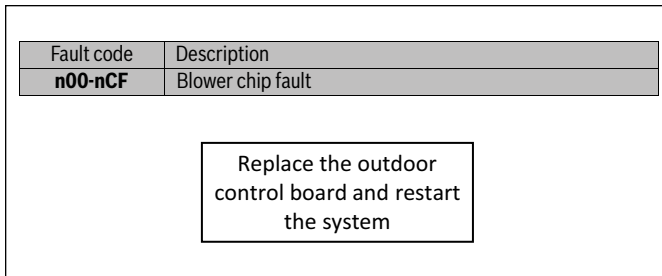

Figure 71

WARNING
Hazardous voltage!
 When measuring resistance , make sure the unit is powered off and wait 3 min before taking measurement.

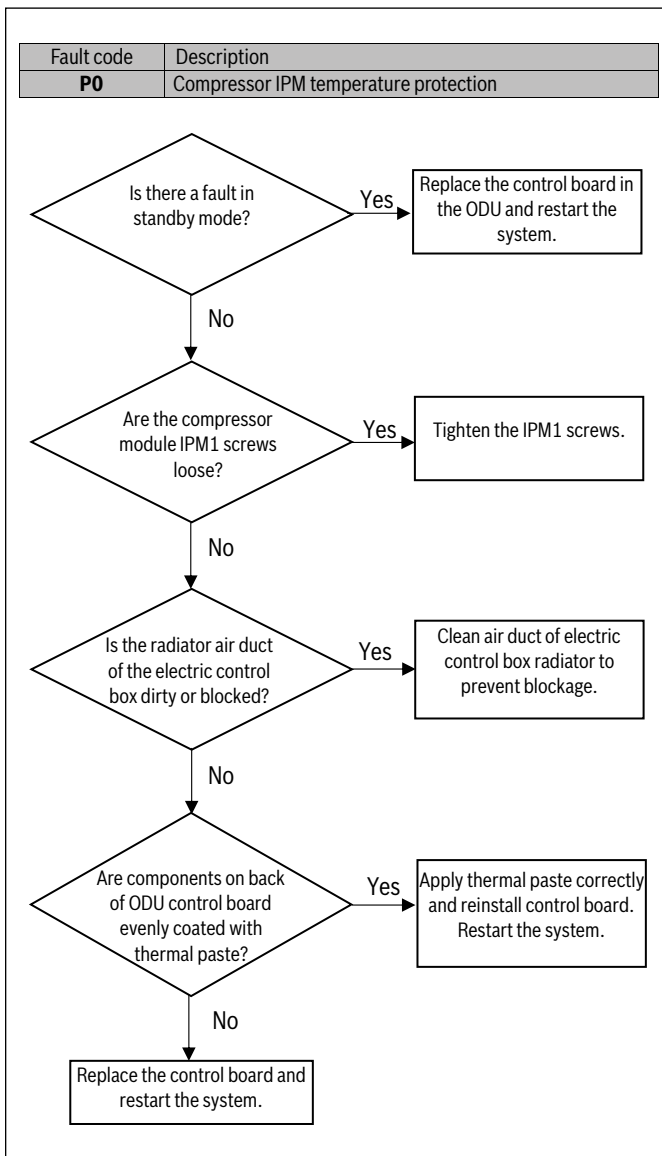

Figure 72

WARNING
Hazardous voltage!
 When measuring resistance , make sure the unit is powered off and wait 3 min before taking measurement.

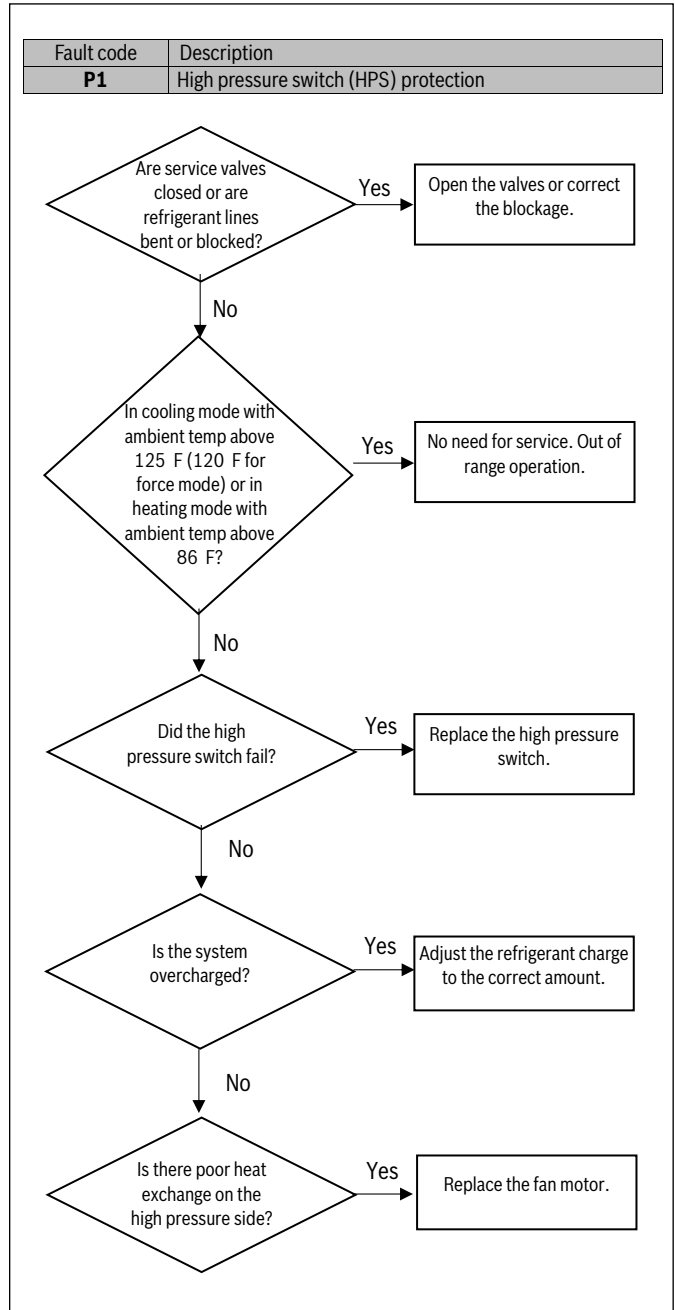

Figure 73

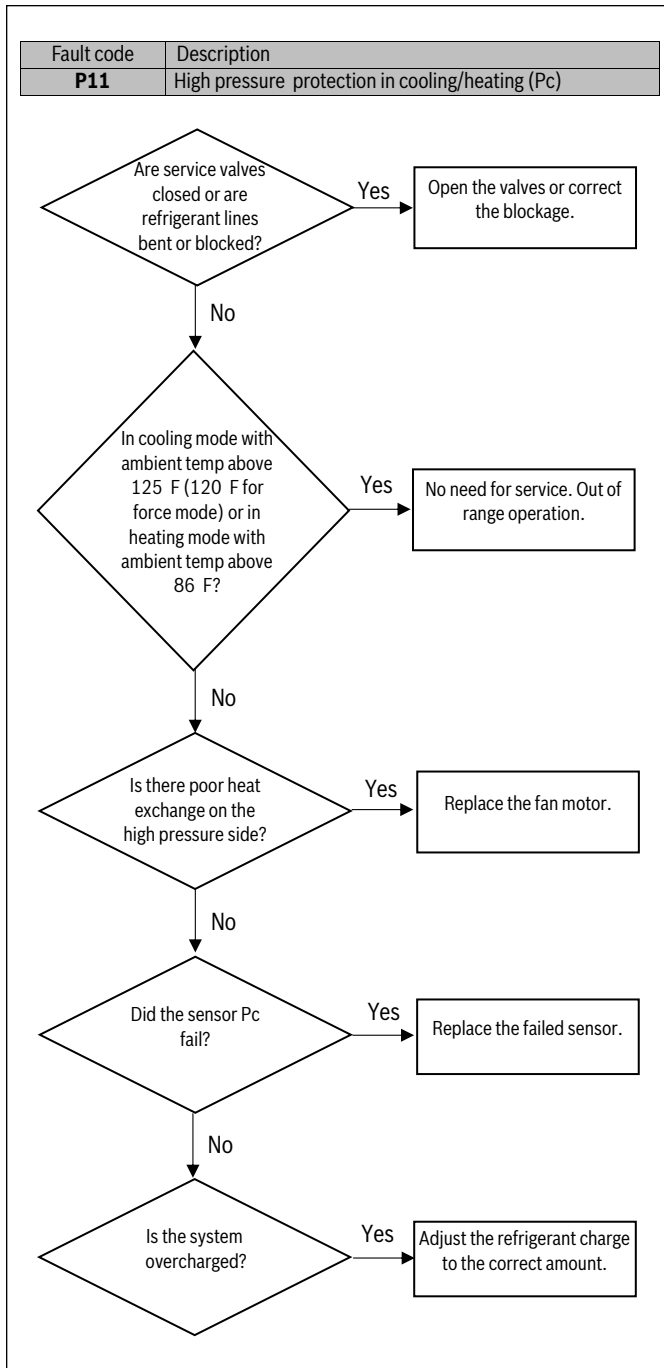

Figure 74

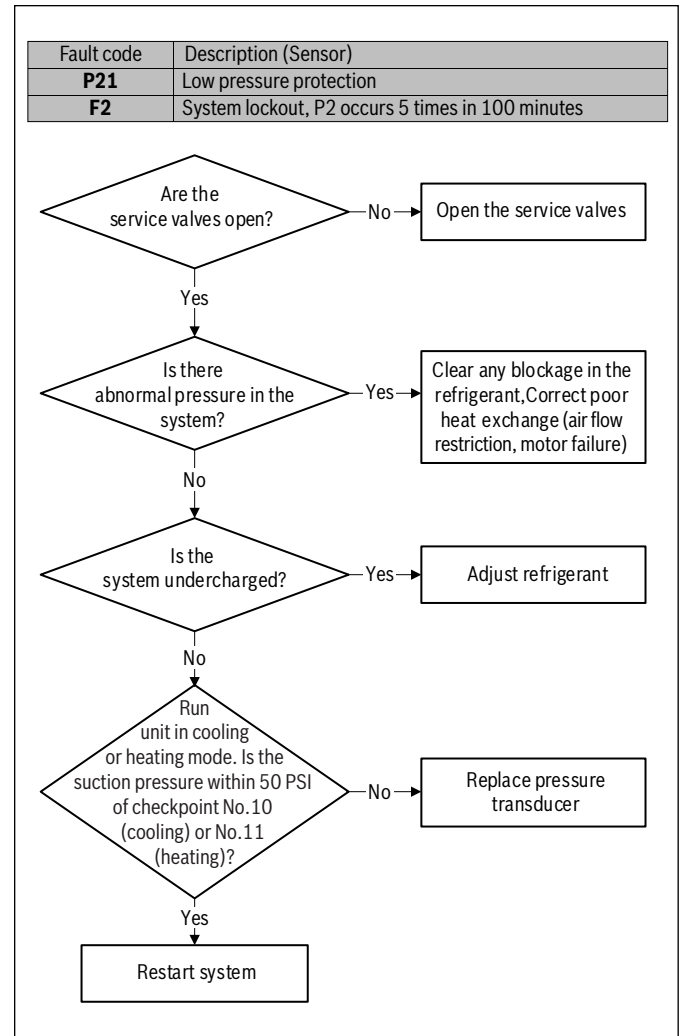

Figure 75

WARNING

Hazardous voltage!

When measuring resistance, make sure the unit is powered off and wait 3 min before taking measurement.

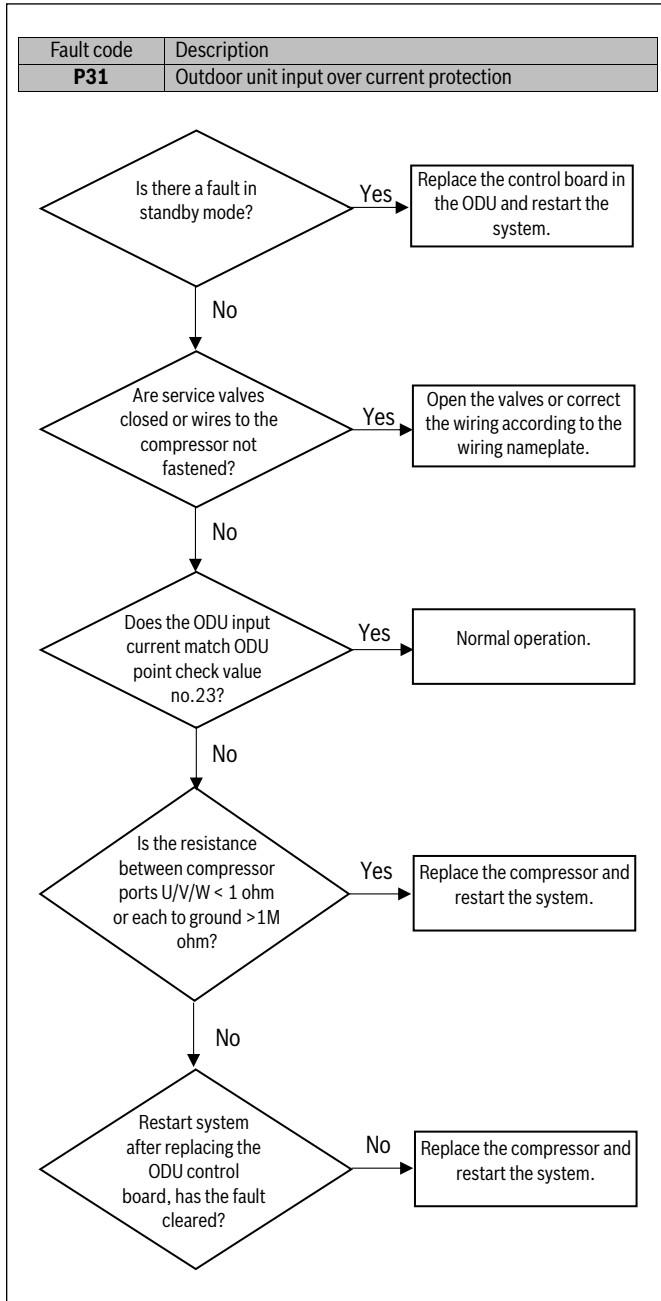

Figure 76

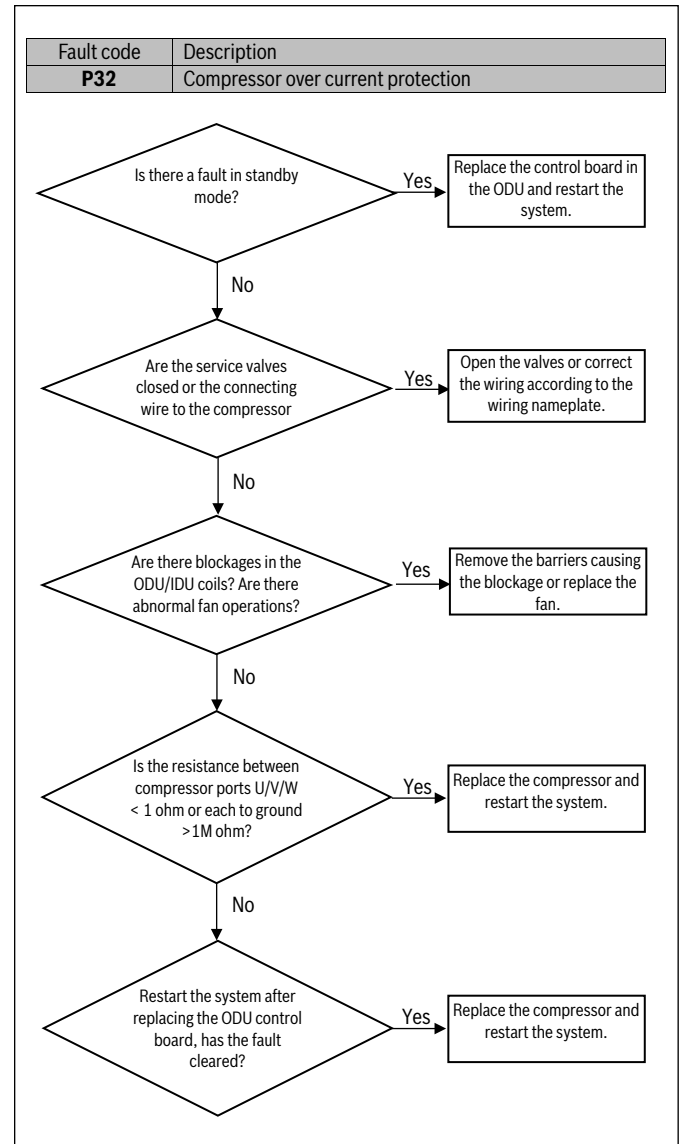

Figure 77

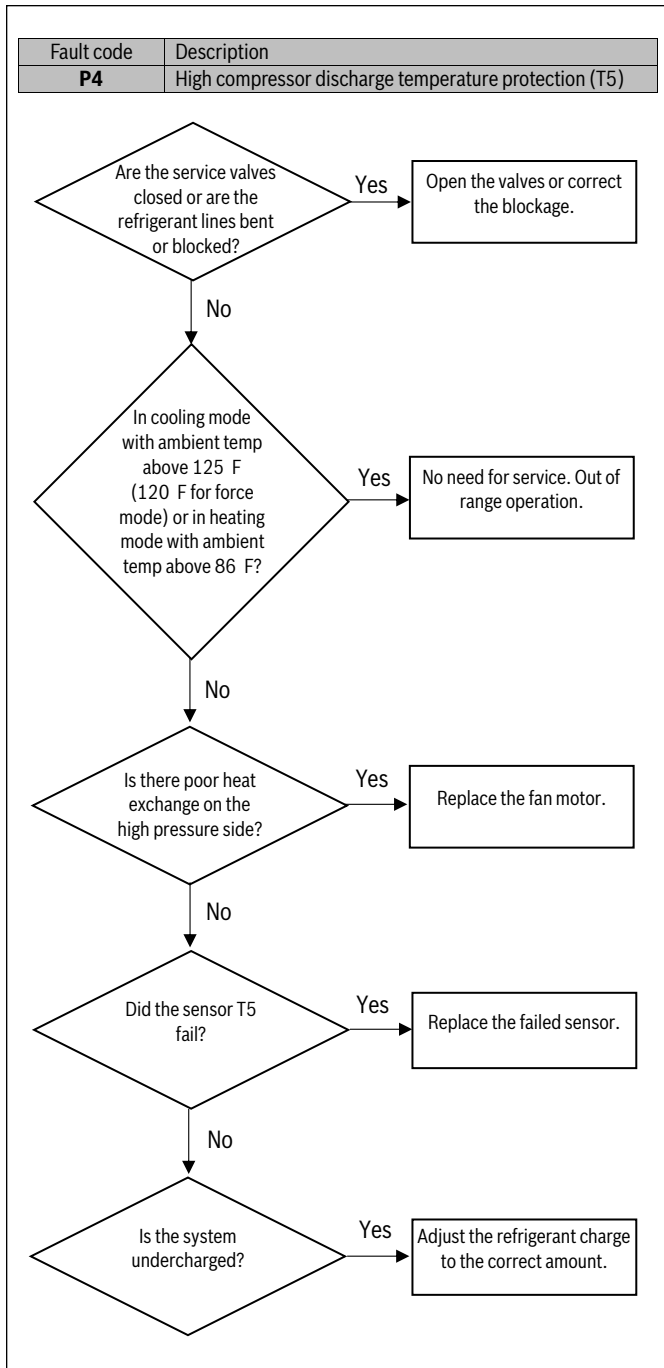

Figure 78

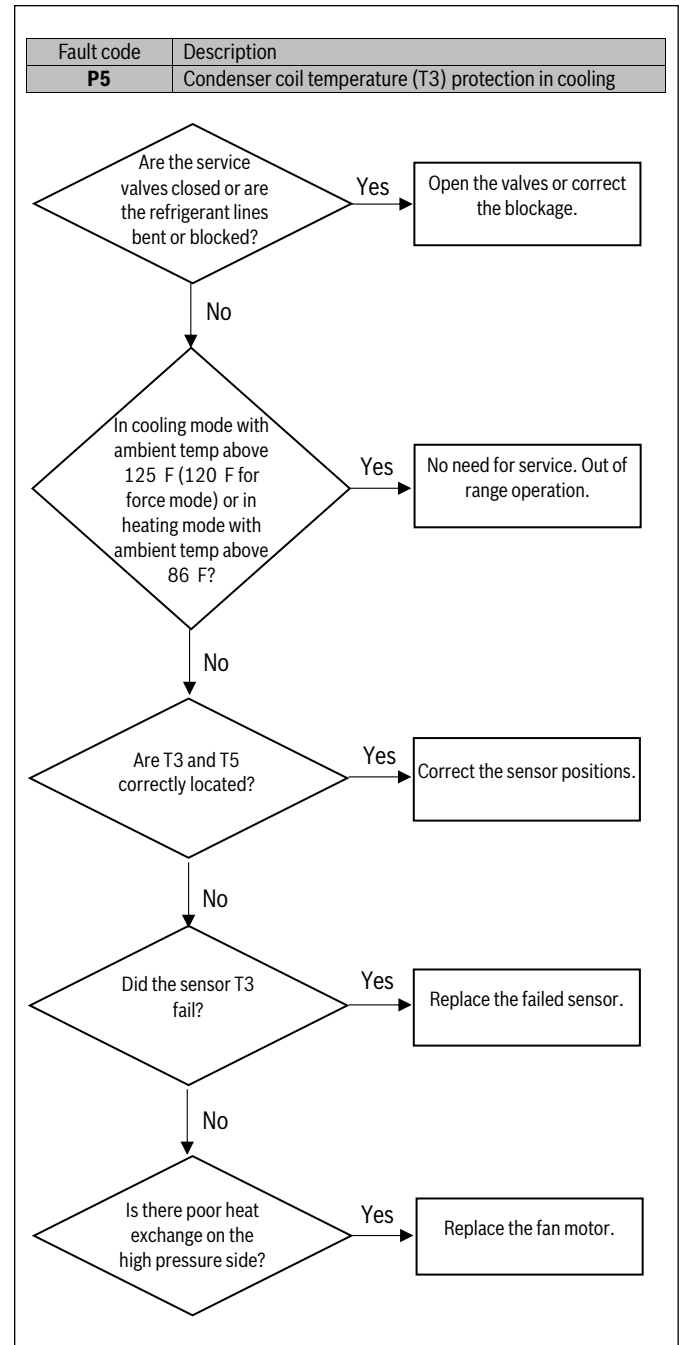

Figure 79

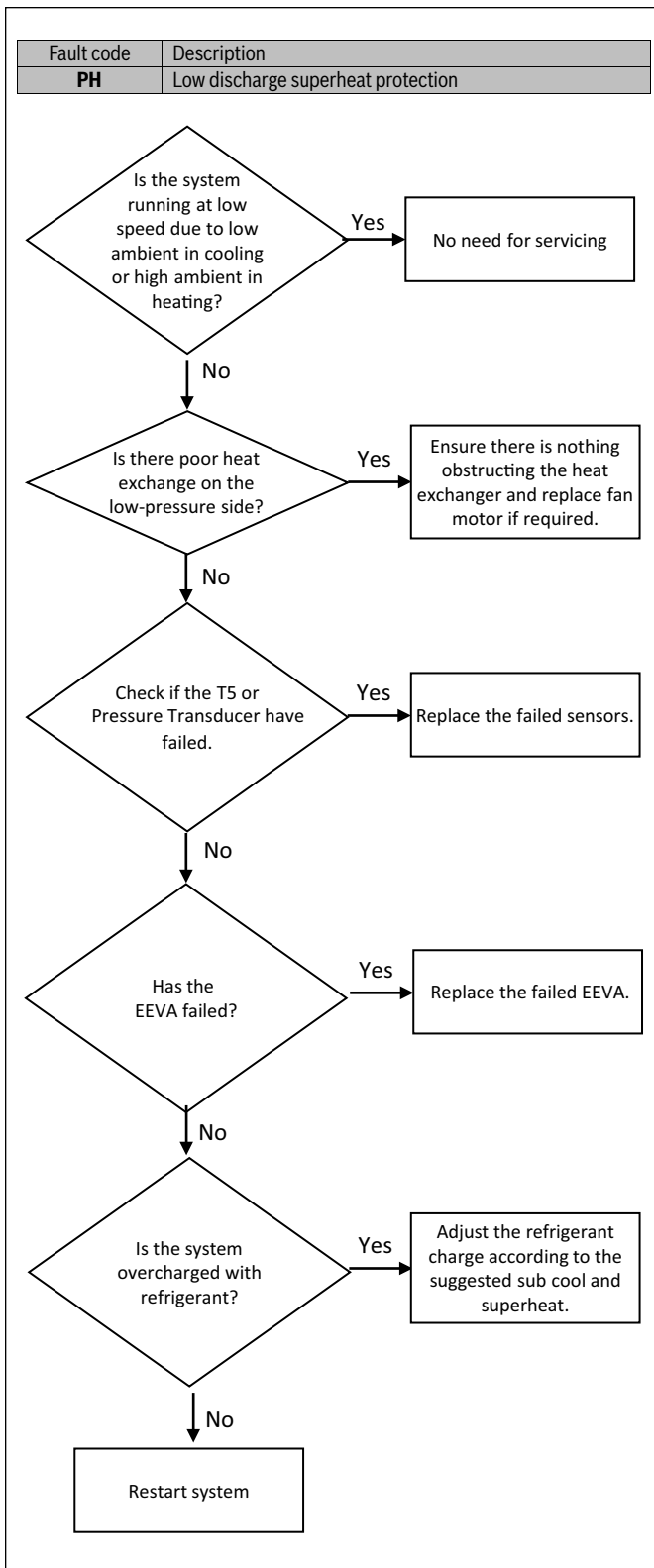

Figure 80

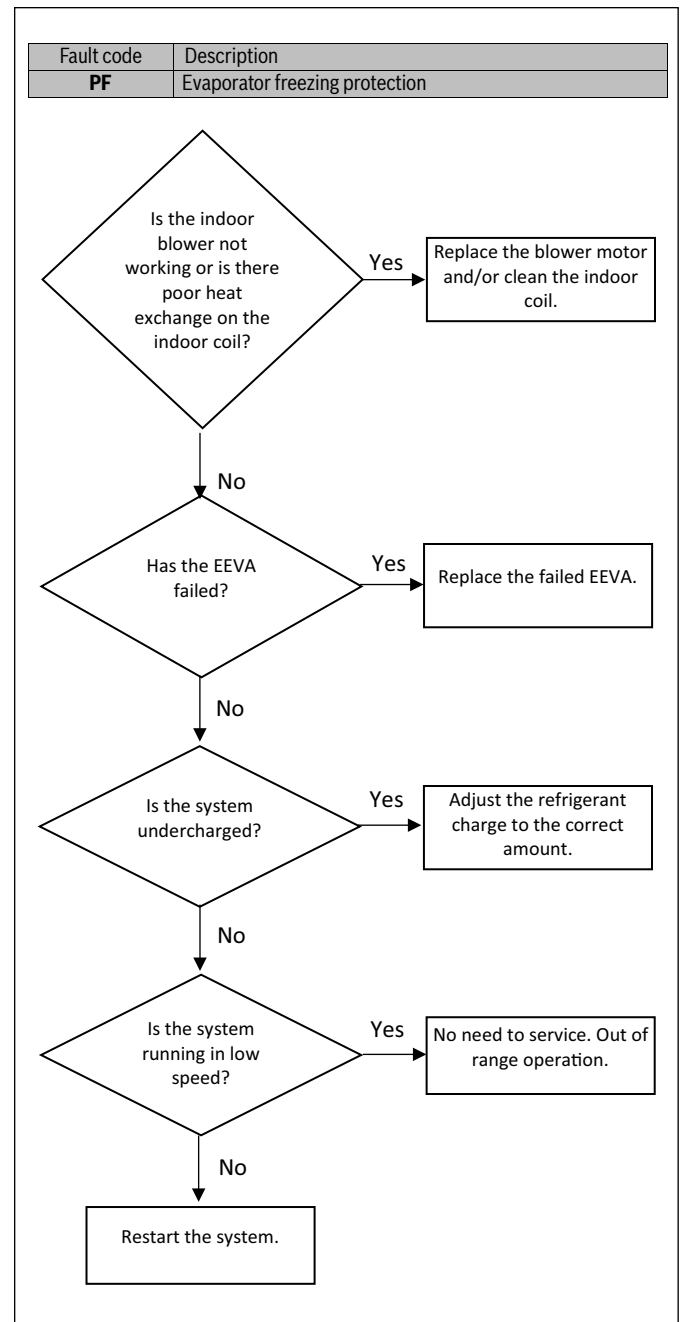

Figure 81

14.12.1 LED Flashing Troubleshooting (IDU)

Indoor unit fault codes can be diagnosed via observing the behavior of LED1. The number of flashes per cycle correspond to certain faults as described below.

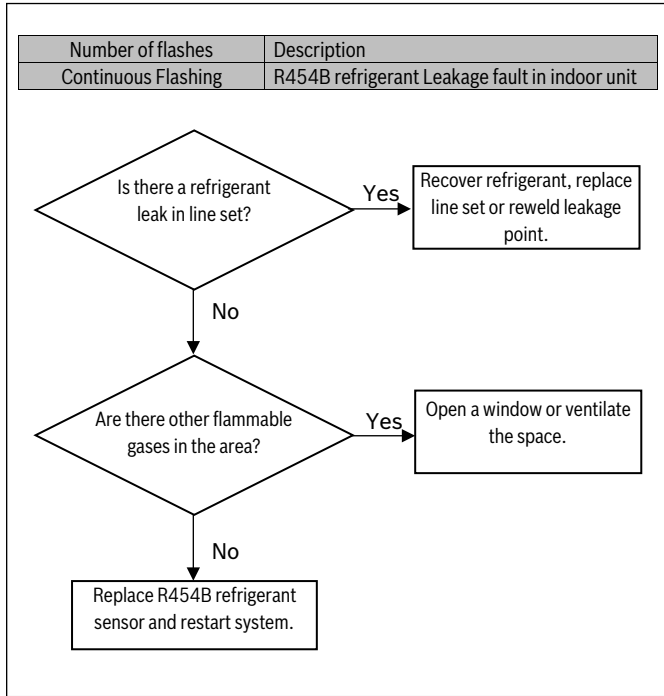

Figure 82

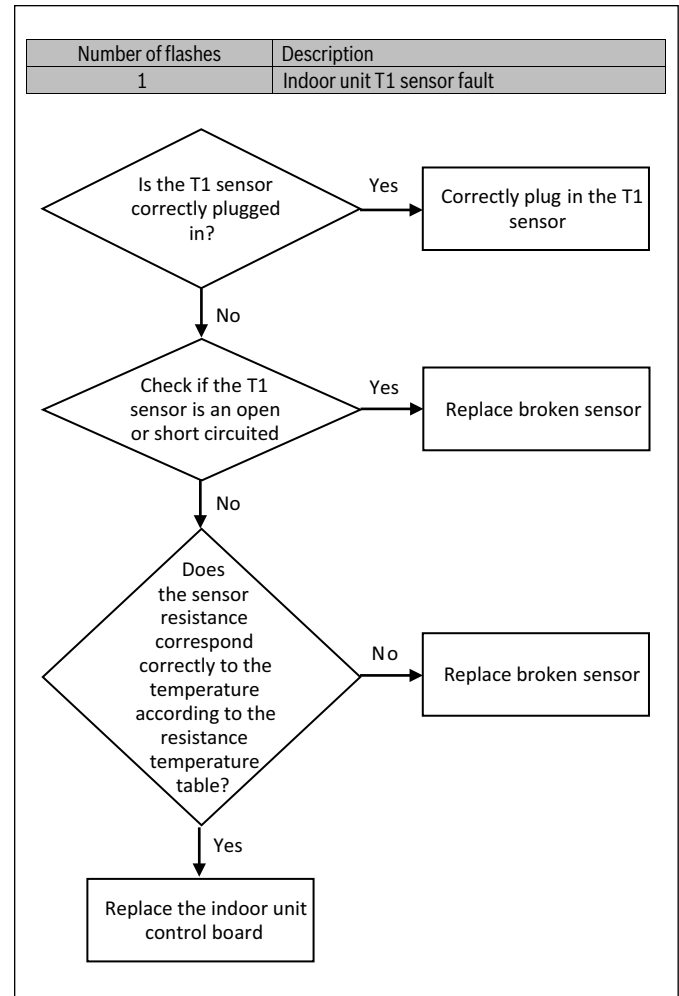

Figure 83

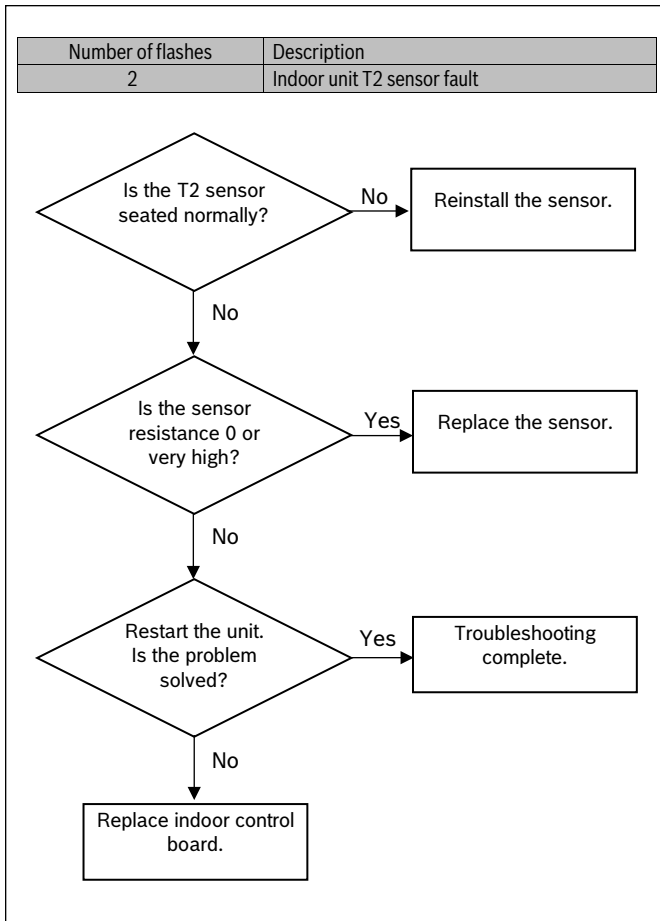

Figure 84

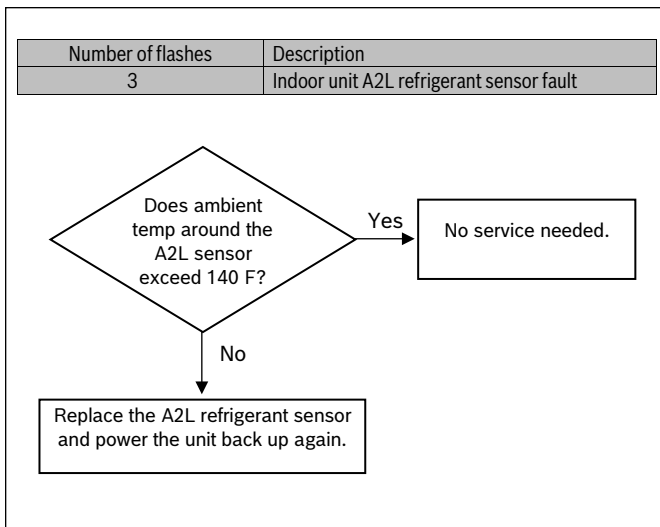

Figure 85

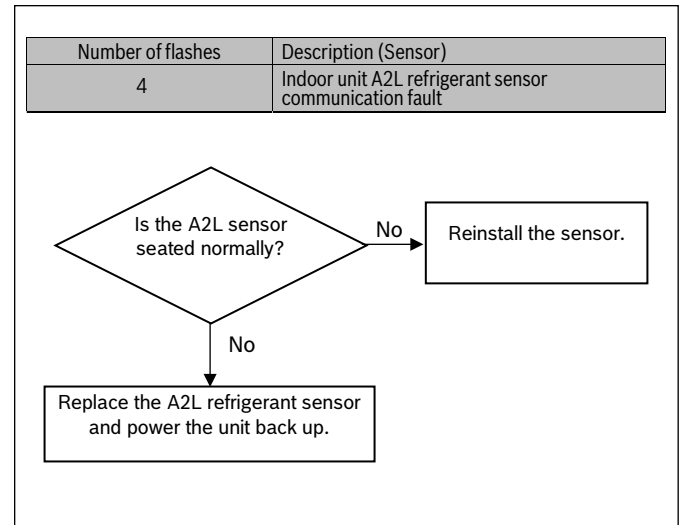

Figure 86

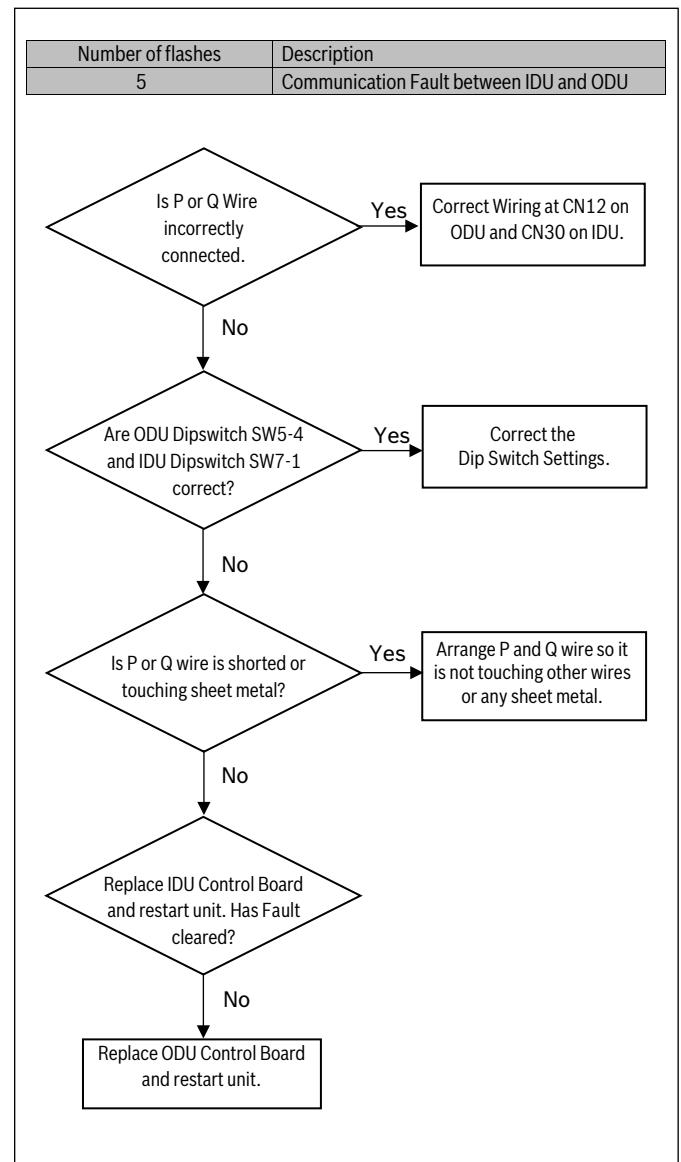

Figure 87

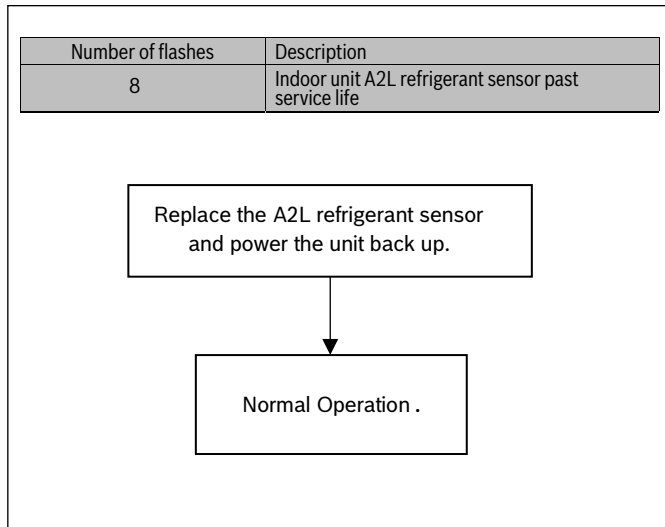

Figure 88

14.12.2 Online Help Resources

Alternatively, please visit our Service & Support webpage to find FAQs, videos, service bulletins, and more; bosch-homecomfort.us/service or use your cellphone to scan the code below.

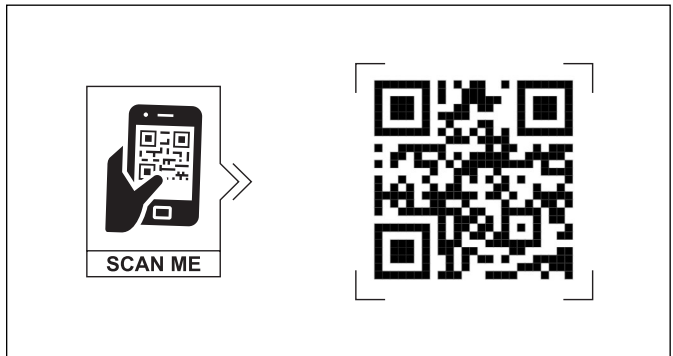

Figure 90

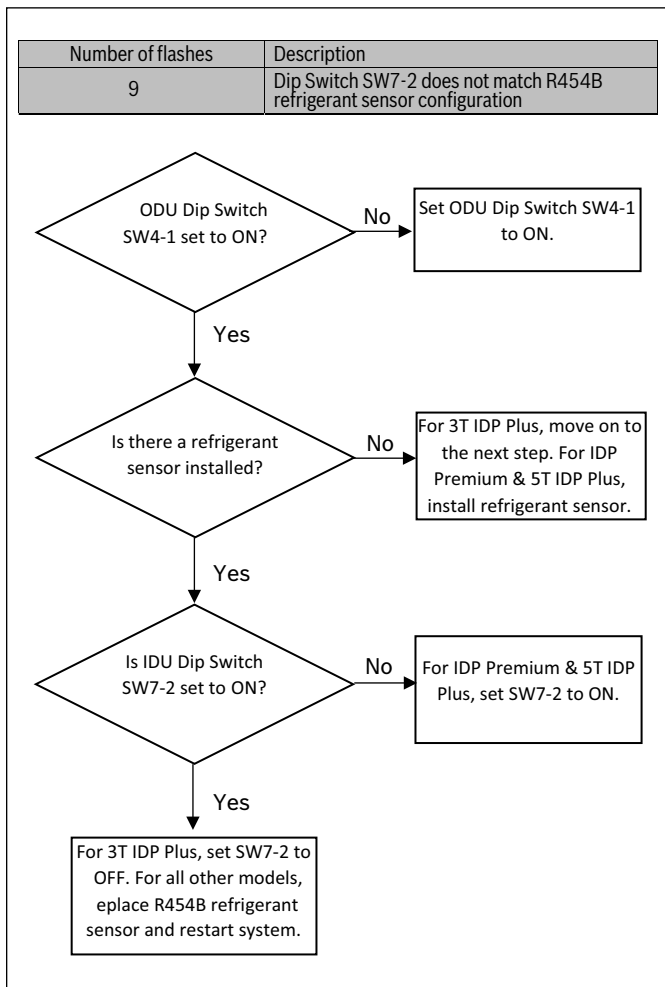

Figure 89

14.13 Temperature and Resistance Relationship Tables (for Sensors)

Temp (°F)	Temp (°C)	Resistance (kΩ)
-20	-28.89	218.11
-15	-26.11	154.74
-10	-23.33	129.74
-5	-20.56	107.73
0	-17.78	99.54
10	-12.22	71.80
20	-6.67	49.65
30	-1.11	36.71
40	4.44	27.39
50	10.00	20.61
60	15.56	15.65
70	21.11	11.99
80	26.67	9.27
90	32.22	7.23
100	37.78	5.68
110	43.33	4.51
120	48.89	3.61
130	54.44	2.90
140	60.00	2.35
150	65.67	1.91
160	71.11	1.57
170	76.67	1.28
180	82.22	1.00
190	87.78	0.91
200	93.33	0.76
210	98.89	0.65
220	104.44	0.56

Table 34 for T3, T4, Th, T3L

14.14 Temperature and Resistance Relationship Tables (for T5 Sensor)

Temp (°F)	Temp (°C)	Resistance (kΩ)
-20	-28.89	862.00
-15	-26.11	725.82
-10	-23.33	612.41
-5	-20.56	600.13
0	-17.78	505.55
10	-12.22	362.74
20	-6.67	265.40
30	-1.11	195.60
40	4.44	146.70
50	10.00	110.71
60	15.56	84.47
70	21.11	65.41
80	26.67	50.90
90	32.22	40.15
100	37.78	31.81
110	43.33	25.51
120	48.89	20.53
130	54.44	16.71
140	60.00	13.64
150	65.67	11.21
160	71.11	9.31
170	76.67	7.75
180	82.22	6.50
190	87.78	5.47
200	93.33	4.65
210	98.89	3.95
220	104.44	3.38

Table 35 for T5

15 Wiring Diagram

WARNING
ELECTRIC HAZARD 380 VOLTS DC
 WAIT 5 MINUTES AFTER DISCONNECTING POWER, THEN VERIFY DC VOLTAGE IS LESS THAN 42 VDC AT INVERTER TEST POINTS P-N. COMPONENTS MAY STORE A DANGEROUS ELECTRICAL POTENTIAL OF 380 VOLTS DC.
 FAILURE TO FOLLOW THIS WARNING COULD RESULT IN PERSONAL INJURY OR DEATH.

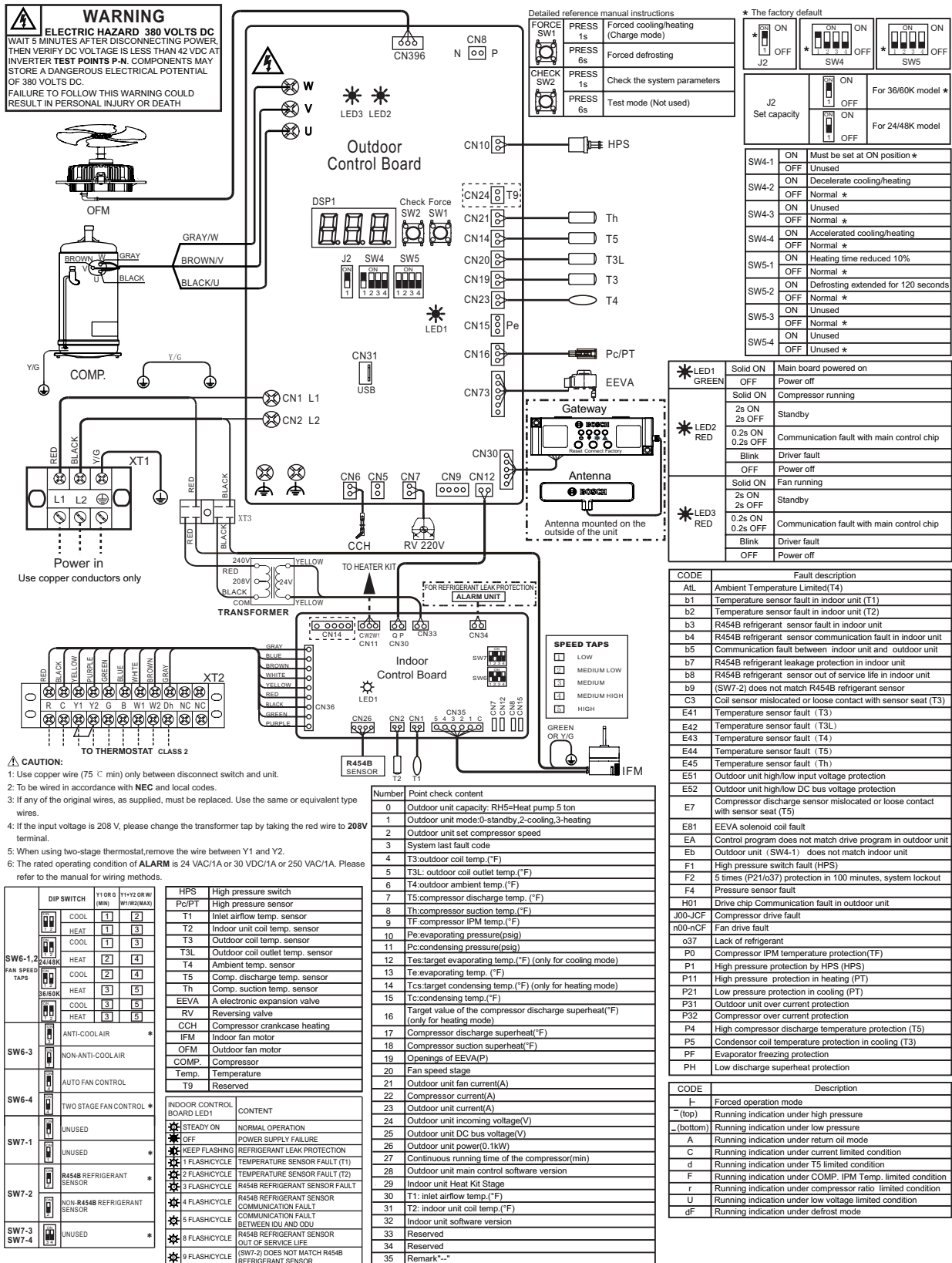

Figure 19

16 Care and Maintenance

16.1 Cleaning Precautions

WARNING

Maintenance and repair!

Any maintenance and cleaning of outdoor unit must be performed by qualified service personnel only.
Any unit repairs must be performed by qualified service personnel only.

CAUTION

Electric shock!

Always turn off your heat pump and disconnect the power supply before cleaning or maintenance. lified service personnel only.

NOTICE

Cleaning!

Do not use chemicals or chemically treated cloths to clean the unit .
Do not use benzene, paint thinner, polishing powder or other solvents to clean the unit.

CAUTION

Personal injury!

When removing filter, do not touch metal parts in the unit. The sharp metal edges can cut you.

16.2 Regular Maintenance

Your heat pump must be inspected regularly by a qualified service technician.

1. Inspect the air filter every ninety days or as often as needed. If blocked or obstructed, clean or replace at once.

Your annual system inspection must include:

2. Inspection and/or cleaning of the blower wheel housing and motor.
3. Inspection and cleaning of indoor and outdoor coils as required.
4. Inspection and/or cleaning of the indoor coil drain pan and drain lines, as well as auxiliary drain pan and lines.
5. Check all electrical wiring and connections. Correct as needed, referring to the wiring diagram. (Refer to Figure 87)

17 Disposal

WARNING

Disposal!

Disposal of unit or components must be performed by qualified service personnel only .
Components and units must be properly disposed in accordance with federal or local regulations.

Components and accessories from the units are not part of ordinary domestic waste.

Complete units , compressors, motors etc. are only to be disposed of via qualified disposal specialists.

This unit uses hydrogen fluorocarbons. Please contact the dealer when you want to dispose of this unit. Law requires that the collection, transportation and disposal of refrigerants must conform with the regulations governing the collection and destruction of hydrofluorocarbons.

18 Care and Maintenance

18.1 Cleaning Precautions

WARNING

Maintenance and repair!

Any maintenance and cleaning of outdoor unit must be performed by qualified service personnel only.
Any unit repairs must be performed by qualified service personnel only.

CAUTION

Electric shock!

Always turn off your heat pump and disconnect the power supply before cleaning or maintenance. lified service personnel only.

NOTICE

Cleaning!

Do not use chemicals or chemically treated cloths to clean the unit .
Do not use benzene, paint thinner, polishing powder or other solvents to clean the unit.

CAUTION

Personal injury!

When removing filter, do not touch metal parts in the unit. The sharp metal edges can cut you.

18.2 Regular Maintenance

Your heat pump must be inspected regularly by a qualified service technician.

1. Inspect the air filter every ninety days or as often as needed. If blocked or obstructed, clean or replace at once.

Your annual system inspection must include:

2. Inspection and/or cleaning of the blower wheel housing and motor.
3. Inspection and cleaning of indoor and outdoor coils as required.
4. Inspection and/or cleaning of the indoor coil drain pan and drain lines, as well as auxiliary drain pan and lines.
5. Check all electrical wiring and connections. Correct as needed, referring to the wiring diagram. (Refer to Figure 87)

19 Disposal



WARNING

Disposal!

Disposal of unit or components must be performed by qualified service personnel only .

Components and units must be properly disposed in accordance with federal or local regulations.

Components and accessories from the units are not part of ordinary domestic waste.

Complete units , compressors, motors etc. are only to be disposed of via qualified disposal specialists.

This unit uses hydrogen fluorocarbons. Please contact the dealer when you want to dispose of this unit. Law requires that the collection, transportation and disposal of refrigerants must conform with the regulations governing the collection and destruction of hydrofluorocarbons.

NOTES:

NOTES:

**United States and Canada
Bosch Thermotechnology Corp.
65 Grove St.
Watertown, MA 02472**

**Tel: 800-283-3787
www.bosch-homecomfort.us**

BTC 762003316 D /02.2026

**Bosch Thermotechnology Corp. reserves the right to
make changes without notice due to continuing
engineering and technological advances.**