

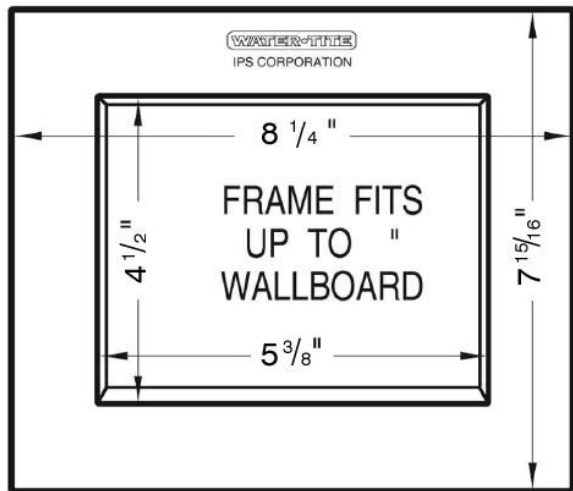

PLASTIC ICE MAKER OUTLET BOXES
with Lead Free Quarter Turn Arrester Valve

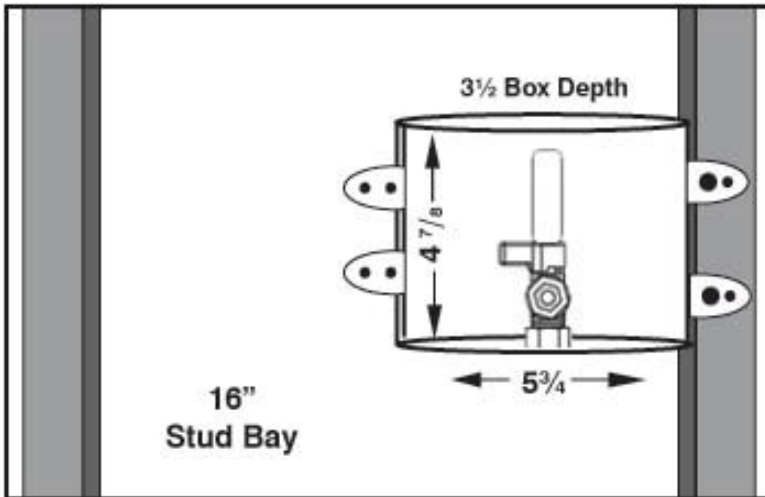

Ice Maker Box Installation Instructions	
1)	Remove the faceplate that is attached to the ice maker box and save for future installation.
2)	Using either nails or screws, mount the box to the stud via the flanges on the side of the box.
3)	Box can be mounted:
a)	On either side of the stud bay.
b)	At a height determined by builder/installer.
c)	In any direction - top mount, etc.
4)	Connect the PEX water supply piping to the ice maker box valve via the ASTM F1807 connection.
5)	Check all local codes for appropriate approvals and requirements.
6)	To the 1/4" outlet of valve attach either:
a)	Copper supply tubing via compression connection.
b)	Poly supply tubing via compression connection - brass insert into poly tube is required
c)	Braided hose via threaded connection.
7)	Connect to the inlet connection of the refrigerator.

✓	Product Code #	Product Description	Model #	Units/Case	Packaging
	87980	Brass Lead Free Qtr Turn Valve w/Arrester Installed - 1/2" F1807 PEX	AB9702HA	10	Standard Pack
	87981	Brass Lead Free Qtr Turn Valve w/Arrester Installed - 1/2" F1807 PEX	AB9702HACP	20	Contractor Pack

Item #	Replacement Component Description
89440	Plastic Locknut for Solder Valves
88367	Lead Free Lean Pex Ice Valve w/Hammer Arrester
89266	Faceplate

