

INDOOR UNIT

Revision A:

• MLZ-KP09/12/18NA2- U1 have been added.

OBD802 is void.

**No. OBD802
REVISED EDITION-A**

TECHNICAL DATA

Models

MLZ-KP09NA - U1

MLZ-KP12NA - U1

MLZ-KP18NA - U1

MLZ-KP09NA2 - U1

MLZ-KP12NA2 - U1

MLZ-KP18NA2 - U1

Outdoor unit technical data
MXZ-C NA, MXZ-C NAHZ Series
(OBD702)

Outdoor unit service manual
MXZ-C NA, MXZ-C NAHZ Series
(OBH702, OCH573)

Indoor unit service manual
MLZ-KP•NA Series (OBH802)

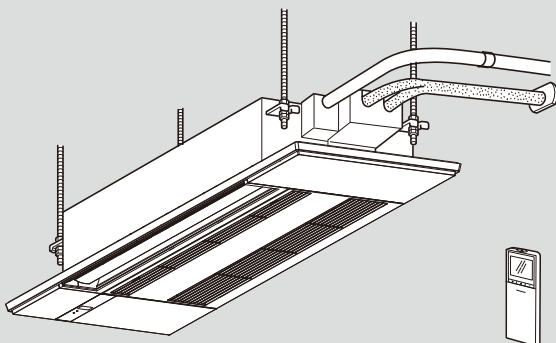

CONTENTS

1. POSITION OF THE CENTER OF GRAVITY	2
2. NOISE CRITERION CURVES	3
3. TEMPERATURE AND AIR FLOW DISTRIBUTIONS	4

Revision A:

• MLZ-KP09/12/18NA2- U1 have been added.

1**POSITION OF THE CENTER OF GRAVITY****Ceiling-cassette type**

Unit: inch (mm)

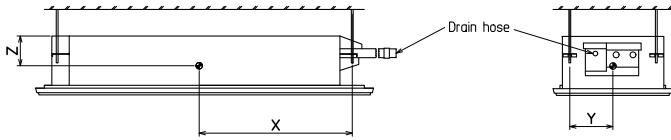

Model name	X	Y	Z
MLZ-KP09NA			
MLZ-KP09NA2			
MLZ-KP12NA	21-7/16	6	4-1/8
MLZ-KP12NA2	(545)	(152)	(105)
MLZ-KP18NA			
MLZ-KP18NA2			

MLZ-KP09NA MLZ-KP09NA2

FAN SPEED	FUNCTION	SPL(dB(A))	LINE
High	COOLING	38	●—●
	HEATING	37	○—○

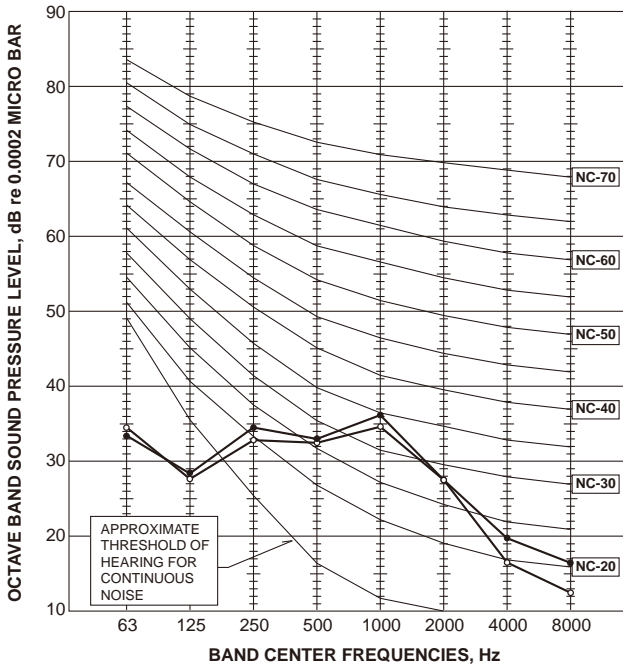

MLZ-KP12NA MLZ-KP12NA2

FAN SPEED	FUNCTION	SPL(dB(A))	LINE
High	COOLING	40	●—●
	HEATING	40	○—○

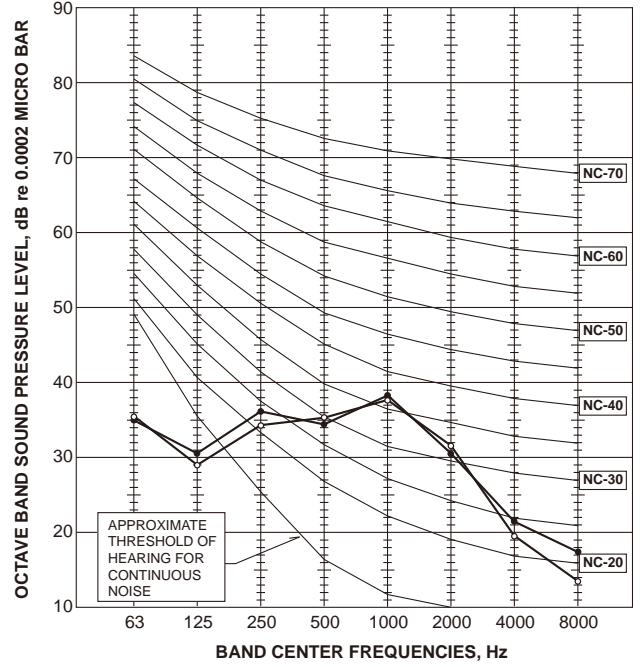

MLZ-KP18NA MLZ-KP18NA2

FAN SPEED	FUNCTION	SPL(dB(A))	LINE
High	COOLING	47	●—●
	HEATING	48	○—○

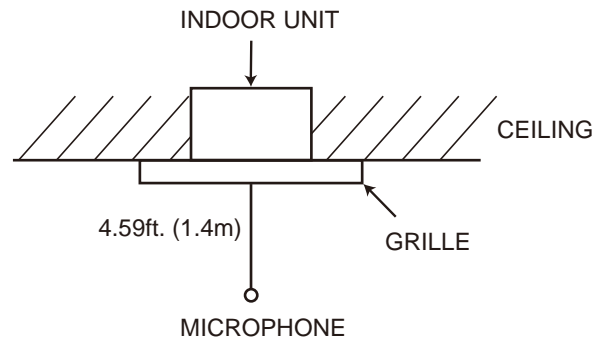
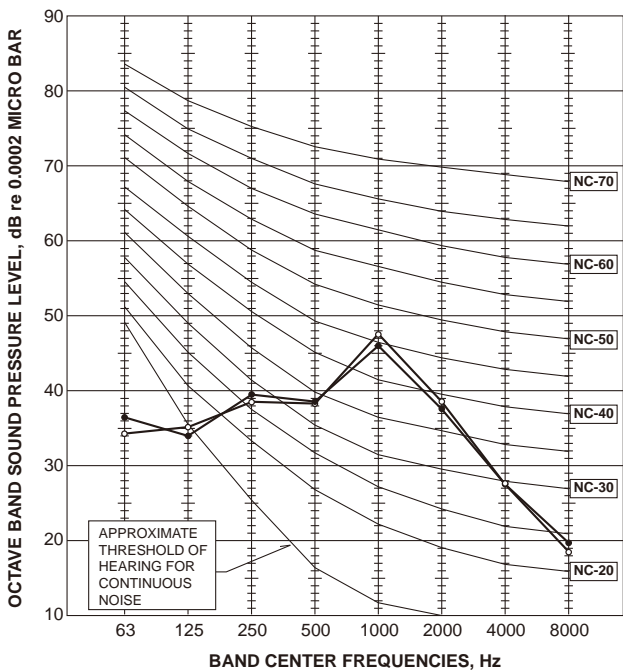

3 TEMPERATURE AND AIR FLOW DISTRIBUTIONS

MLZ-KP09NA MLZ-KP09NA2

Temperature distribution

<Cooling mode> Air volume: high
Air direction: auto (upward air flow)

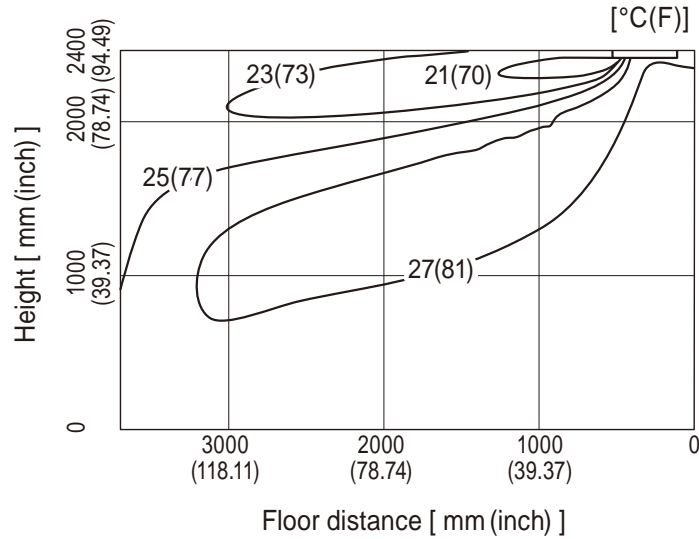

<Heating mode> Air volume: high
Air direction: auto (downward air flow)

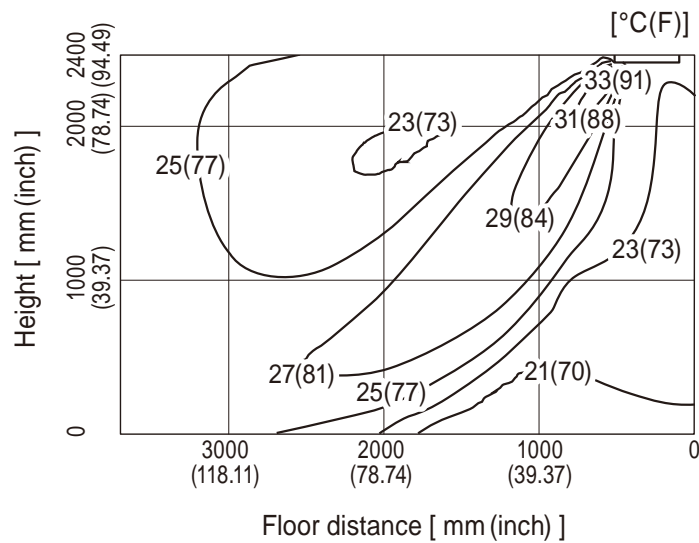

Note : These figures show typical airflow distributions in the conditions above. In the actual installation, they may differ from these figures under the influence of air temperature conditions, ceiling height, cooling/heating load, obstacles, etc.

MLZ-KP09NA MLZ-KP09NA2

Airflow distribution

<Cooling mode>

Air volume: high
Air direction: auto (upward air flow)

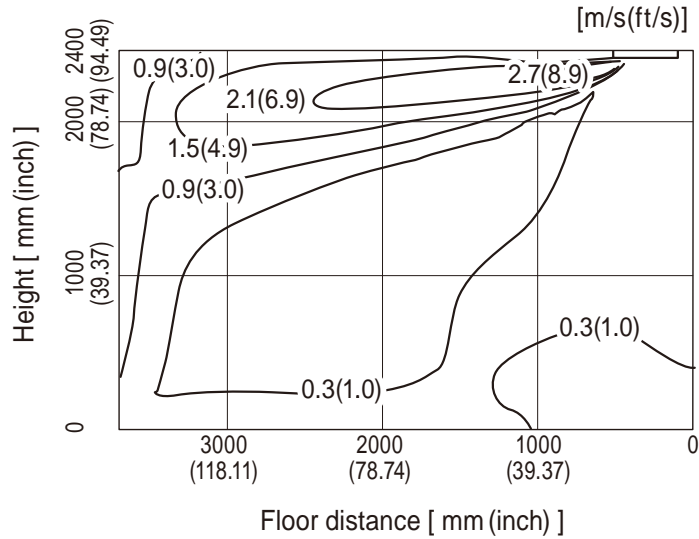

<Heating mode>

Air volume: high
Air direction: auto (downward air flow)

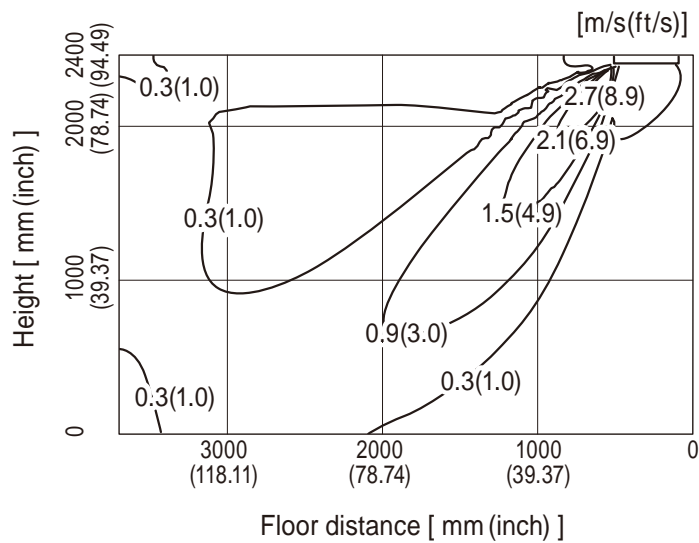

Note : These figures show typical airflow distributions in the conditions above. In the actual installation, they may differ from these figures under the influence of air temperature conditions, ceiling height, cooling/heating load, obstacles, etc.

MLZ-KP12NA MLZ-KP12NA2

Temperature distribution

<Cooling mode>

Air volume: high
Air direction: auto (upward air flow)

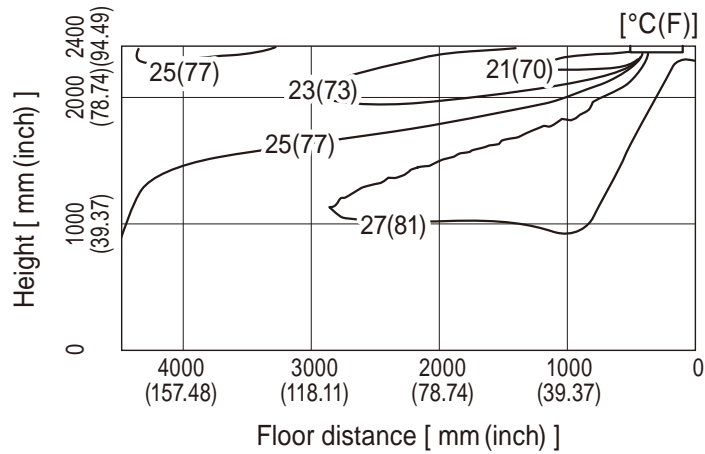

<Heating mode>

Air volume: high
Air direction: auto (downward air flow)

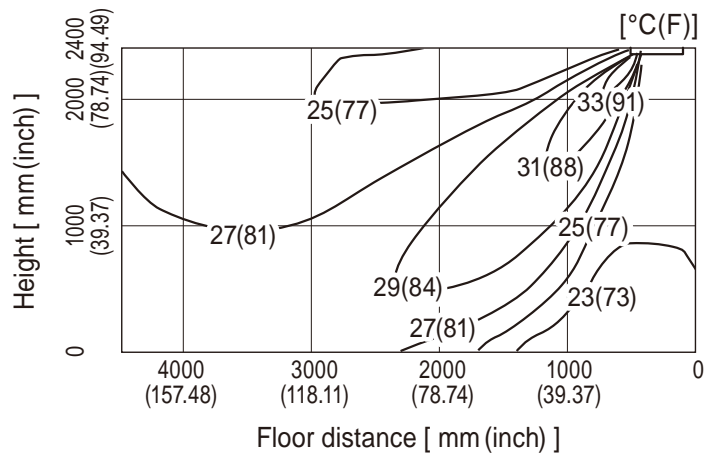

Note : These figures show typical airflow distributions in the conditions above. In the actual installation, they may differ from these figures under the influence of air temperature conditions, ceiling height, cooling/heating load, obstacles, etc.

MLZ-KP12NA MLZ-KP12NA2

Airflow distribution

<Cooling mode>

Air volume: high
Air direction: auto (upward air flow)

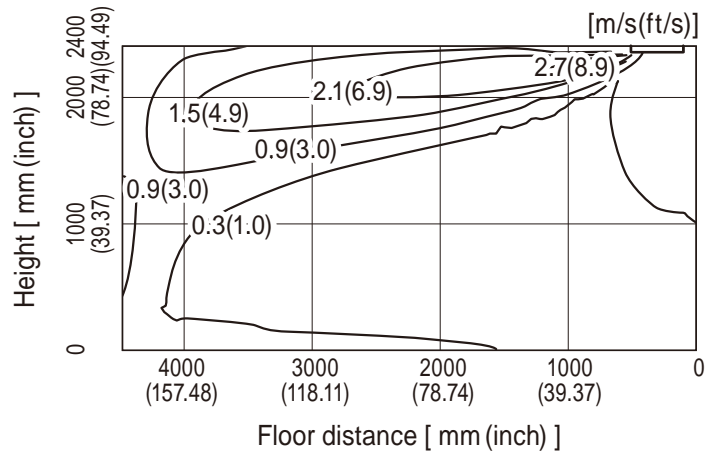

<Heating mode>

Air volume: high
Air direction: auto (downward air flow)

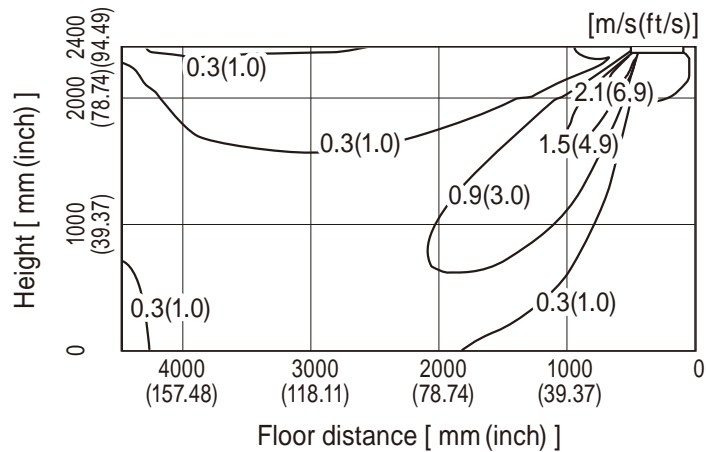

Note : These figures show typical airflow distributions in the conditions above. In the actual installation, they may differ from these figures under the influence of air temperature conditions, ceiling height, cooling/heating load, obstacles, etc.

MLZ-KP18NA MLZ-KP18NA2

Temperature distribution

<Cooling mode>

Air volume: high
Air direction: auto (upward air flow)

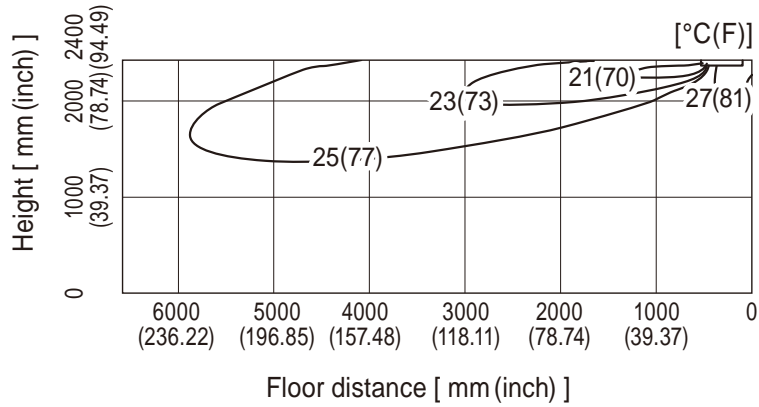

<Heating mode>

Air volume: high
Air direction: auto (downward air flow)

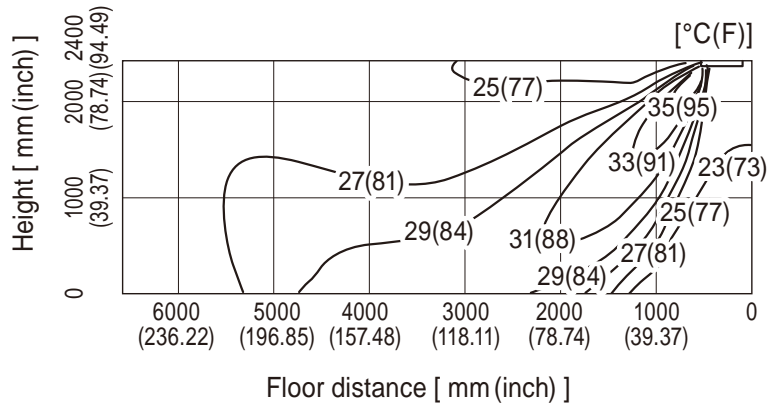

Note : These figures show typical airflow distributions in the conditions above. In the actual installation, they may differ from these figures under the influence of air temperature conditions, ceiling height, cooling/heating load, obstacles, etc.

MLZ-KP18NA MLZ-KP18NA2

Airflow distribution

<Cooling mode> Air volume: high
 Air direction: auto (upward air flow)

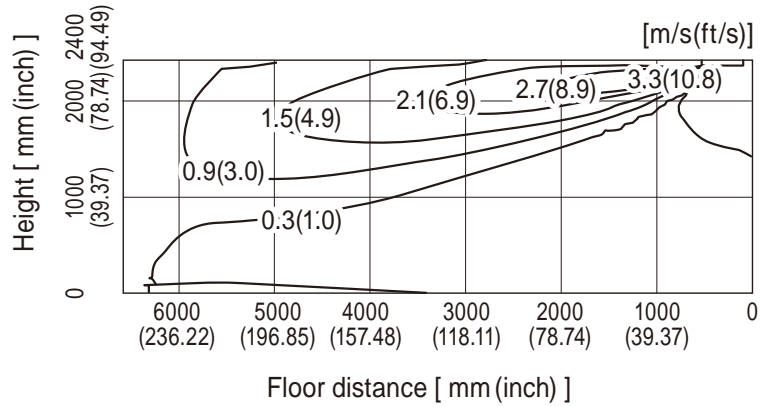

<Heating mode> Air volume: high
 Air direction: auto (downward air flow)

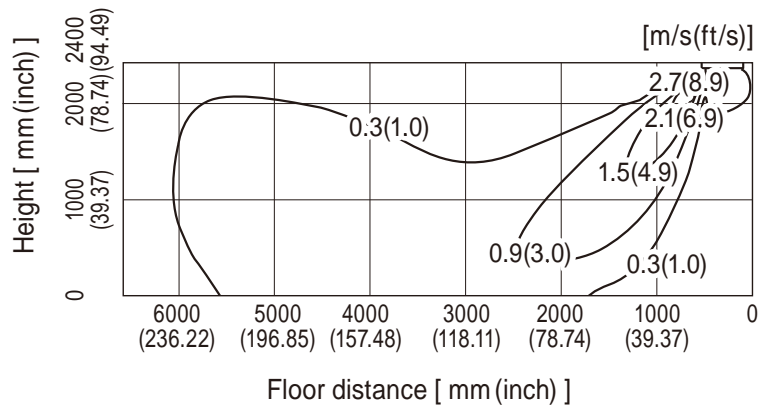

Note : These figures show typical airflow distributions in the conditions above. In the actual installation, they may differ from these figures under the influence of air temperature conditions, ceiling height, cooling/heating load, obstacles, etc.

mitsubishi electric corporation

HEAD OFFICE: TOKYO BUILDING, 2-7-3, MARUNOUCHI, CHIYODA-KU, TOKYO 100-8310, JAPAN

© Copyright 2018 MITSUBISHI ELECTRIC CORPORATION

Issued: Apr. 2022. No. OBD802 REVISED EDITION-A

Published: Nov. 2018. No. OBD802 IN M-E0764

Made in Japan

Specifications are subject to change without notice.