

CU 302

Installation and operating instructions



CU 302
Installation and operating instructions
(all available languages)
<http://net.grundfos.com/qr/i/92852550>

CU 302

English (GB)

Installation and operating instructions	4
Limited consumer warranty	64
Limited manufacturer's warranty	67

English (GB) Installation and operating instructions

Original installation and operating instructions

Table of contents

1. General information	5	8.2	How to enable Bluetooth on the operating panel	27
1.1 Hazard statements	5	8.3	How to disable Bluetooth on the operating panel	27
1.2 Notes	5	9. Control modes	28	
2. Product introduction	6	9.1	Constant pressure (Analog input)	28
2.1 Product description	6	9.2	Level control - Filling	29
2.2 Intended use	6	9.3	Level control - Emptying	31
2.3 SQE pump	6	9.4	Pressure control (Digital input)	33
2.4 Features	6	9.5	Pressure control (Analog input)	34
2.5 Mains borne signalling	7	9.6	Pump out	35
2.6 Pump operation	8	9.7	Pump monitoring	36
2.7 Flow detection	8	10. Grundfos GO dashboard	37	
2.8 System limits	9	10.1	Event notifications	37
2.9 System sizing	9	10.2	Product information	37
2.10 Pressure sensor	10	10.3	Settings	38
2.11 Dry-running protection	11	10.4	Pump status and state	39
2.12 Built-in protection	12	10.5	Start/stop the control mode	39
3. Receiving the product	13	10.6	Control mode metrics	39
3.1 Inspecting the product	13	10.7	View all metrics	40
3.2 Scope of delivery	13	10.8	Setpoint	41
3.3 Identification	13	10.9	Control mode	41
4. Installation requirements	14	10.10	Installation log	41
4.1 Location	14	10.11	Scheduling	41
4.2 Security	14	11. Setting the product	42	
5. Mechanical installation	15	11.1	Setting by means of Grundfos GO	42
5.1 Removing the front cover	15	11.2	Application settings	42
5.2 Disconnecting the front cover	16	11.3	Pump settings	46
5.3 Installing the controller	17	11.4	Special functions	47
5.4 Mounting the rubber seals	18	11.5	Communication	48
5.5 Accessories in the cable gland set	19	11.6	General	49
5.6 Removing the screw (UL variants only)	19	12. Service	51	
6. Electrical connection	20	12.1	Updating the product software	51
6.1 Cable requirements	20	12.2	Replacing the battery	51
6.2 Protection of controller and supply cables	21	13. Fault finding	52	
6.3 Connecting the pump supply and power supply	21	13.1	Alarm and warning codes	52
6.4 Connecting a level sensor	23	14. Remote monitoring	61	
6.5 RS-485 input and output	23	15. Decommissioning	61	
6.6 Terminal blocks	24	16. Technical data	61	
6.7 Sensor input	24	16.1	Electrical data	61
7. Control functions	25	16.2	Temperature	62
7.1 Operating panel	25	16.3	Environmental data	62
7.2 Grundfos Eye	26	16.4	Dimensions	62
8. Starting up the product	27	16.5	Weights	62
8.1 Connecting to Grundfos GO	27	16.6	Miscellaneous data	62
		17. Disposing of the product	63	

18. Product feedback	63
--------------------------------	----

19. Document quality feedback	63
---	----

1. General information



Read this document before you install the product. Installation and operation must comply with local regulations and accepted codes of good practice.

1.1 Hazard statements

The symbols and hazard statements below may appear in Grundfos installation and operating instructions, safety instructions and service instructions.



DANGER

Indicates a hazardous situation which, if not avoided, will result in death or serious personal injury.



WARNING

Indicates a hazardous situation which, if not avoided, could result in death or serious personal injury.



CAUTION

Indicates a hazardous situation which, if not avoided, could result in minor or moderate personal injury.

The hazard statements are structured in the following way:



SIGNAL WORD

Description of the hazard

Consequence of ignoring the warning

- Action to avoid the hazard.

1.2 Notes

The symbols and notes below may appear in Grundfos installation and operating instructions, safety instructions and service instructions.



Observe these instructions for explosion-proof products.



A blue or grey circle with a white graphical symbol indicates that an action must be taken.



A red or grey circle with a diagonal bar, possibly with a black graphical symbol, indicates that an action must not be taken or must be stopped.



If these instructions are not observed, it may result in malfunction or damage to the equipment.



Tips and advice that make the work easier.

2. Product introduction

2.1 Product description

The controller operates according to the water pressure measured by a pressure sensor in the installation.

When water is consumed, the system detects flow together with pressure change. The controller starts the pump, and the pump performance and the water flow is controlled by changing the pump speed.

Default setup:

- Constant pressure: 2-5 bar (20-100 psi)
- Setpoint: 3 bar (50 psi)
- CIO 1 is used for analog sensor
- CIO 2 is set up for digital outputs

When the pump is running, the output will change contact position.

The controller can be used in multiple different applications by changing its configuration.



CU 302

2.2 Intended use

CU 302 is intended for controlling and/or monitoring SQE pumps using power line communication.

CU 302 comes pre-configured for constant pressure application with an analog sensor 0-6 bar (0-120 psi), depending on the variant.

The CU 302 input signals can both be analog sensors or digital switches.

The figure below shows an example of an installation with constant-pressure control.

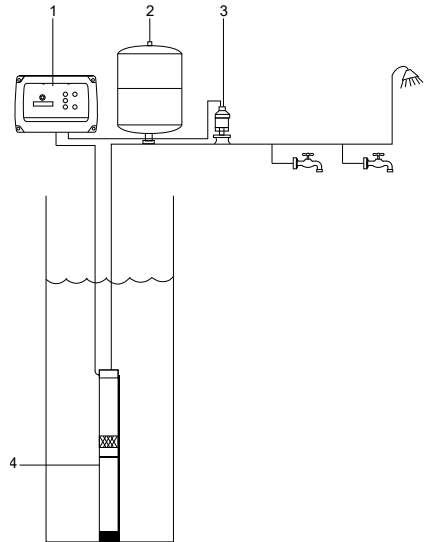

TMC89314

Pos.	Description
1	CU 302
2	Diaphragm tank
3	Pressure sensor
4	SQE pump

2.3 SQE pump

The SQE pump is a 3" submersible pump for domestic water supply, pressure boosting, water transfer, irrigation, and small water works.

The SQE has a built-in frequency drive with a wide operating voltage and variable speed. It provides soft start, and built-in protection. It is equipped with a single phase motor with permanent magnet rotor ensuring optimum efficiency within a wide load range.

2.4 Features

The main features of the CU 302 controller:

- pre-set for constant pressure, and also supports a variety of other applications
- configurable input/output
- manual and automatic control of the pump
- operating indication on the front of the controller, such as power on and pump running
- alarm and warning indication
- Bluetooth pairing with Grundfos GO app.

2.5 Mains borne signalling

The controller communicates with the pump via the power cable.

This communication principle is called mains borne signalling, or power line communication. Using this principle means that no additional cables are required to the pump.

Data is communicated via a high-frequency signal transmitted to the power cable and led into the electronics by signal coils built in the motor and controller.

In case of multiple controller pump power cables installed less than 25-30 cm (10-12 inch) apart in wiring trays, or conduit, undesired communication can occur between units displaying **No contact**.

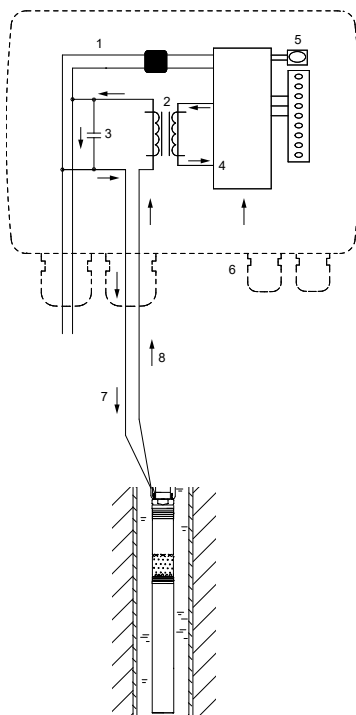

TM083417

Principle of mains borne signalling (power line communication)

Pos.	Description
1	Supply to the electronics
2	Signal coils
3	Capacitor
4	Electronics for the control of the communication
5	ON/OFF button
6	Sensor signal
7	Power supply
8	Communication signals

Related information

[11.5 Communication](#)

2.6 Pump operation

The pump starts as a consequence of the following:

- a high flow
- a low pressure
- a combination of both.

To ensure that the pump starts when water is consumed, a flow detection is required. The flow is detected through pressure changes in the system. When water is consumed, the pressure drops accordingly depending on the size of the diaphragm tank and the water flow:

- at a low flow, the pressure drops slowly
- at a high flow, the pressure drops quickly.

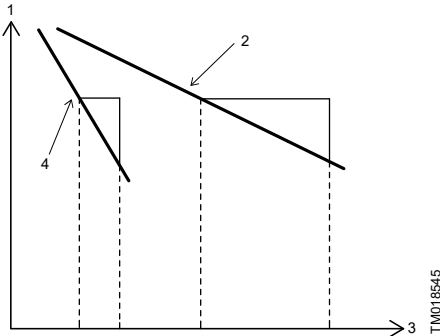

Pos.	Description
1	Pressure
2	Low flow
3	Time
4	High flow

When the pressure drops 0.1 bar/s (1.4 psi/s) or faster, the pump starts immediately.

If a diaphragm tank of 8 liters (2 gal) is used, the pump starts at a flow rate of approximately 0.18 m³/h (0.8 gpm). If a larger tank is used, the flow must be higher before the pump starts.

Consumption up to 0.18 m³/h (0.8 gpm)

The pump starts when the pressure drops to 0.5 bar (7 psi) below the pressure setting.

The pump runs until the pressure is 0.5 bar (7 psi) above the pressure set.

2.7 Flow detection

During pump operation, when water is consumed, the controller adjusts the pump speed to maintain a constant pressure. To stop the pump when no water is consumed, the controller performs flow detection every 10 seconds.

The pump speed is reduced until a small pressure drop is registered. This pressure drop indicates that water is consumed and the pump speed is resumed.

If the pump speed reduces without any pressure drop being registered, this indicates that no water is consumed. The diaphragm tank is filled with water and the pump stops.

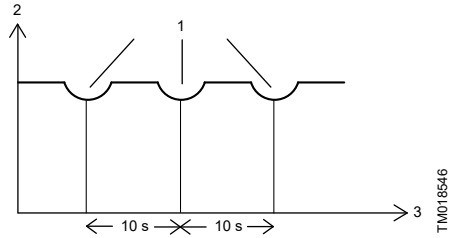

Flow detection every 10 seconds during operation

Pos.	Description
1	Flow detection
2	Pressure
3	Time

2.8 System limits

Even though the controller controls the pressure within ± 0.2 bar (3 psi), bigger pressure variations may occur in the system. If the consumption is suddenly changed, for example, if a tap is opened, the water must start flowing before the pressure can be made constant again. Such dynamic variations depend on the pipes, but, typically, they will lie between 0.5 and 1 bar (7 and 14 psi).

If the desired consumption is higher than the quantity the pump is able to deliver at the desired pressure, the pressure follows the pump curve as illustrated in the figure below.

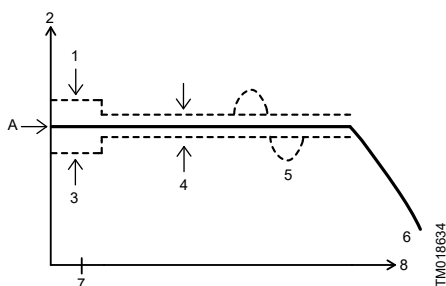

Possible pressure variations during constant-pressure operation

Pos.	Description
1	Stop + 0.5 bar (+ 7 psi)
2	Pressure
3	Start - 0.5 bar (- 7 psi)
4	Controlling ± 0.2 bar (± 3 psi)
5	Dynamic variations ± 0.5 bar (± 7 psi)
6	Flow
7	0.18
8	m^3/h (gpm)
A	Pressure set

Related information

9.1 Constant pressure (Analog input)

2.9 System sizing

To ensure the correct function of the system, the right pump type must be used.

During operation, the controller controls the pump speed within the range 3000-10,700 rpm.

We recommend to follow the guidelines below:

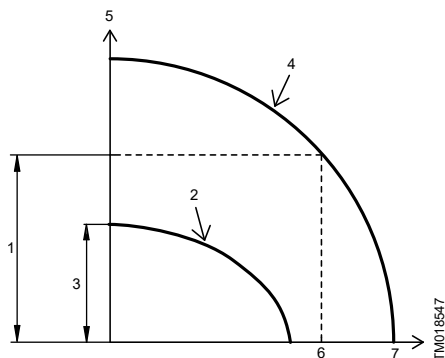

Pump curves

Pos.	Description
1	Max. head at max. flow
2	Pump curve at 3000 rpm
3	Min. head at no flow
4	Pump curve at 10,700 rpm
5	H [m]
6	Q_{max}
7	Q [m^3/h (gpm)]

The following must be fulfilled:

- minimum head at no flow < (static head + system pressure)
- maximum head at maximum flow > (dynamic head + system pressure)

2.10 Pressure sensor

2.10.1 Positioning the pressure sensor

The controller keeps the pressure constant in the place where the pressure sensor is positioned.

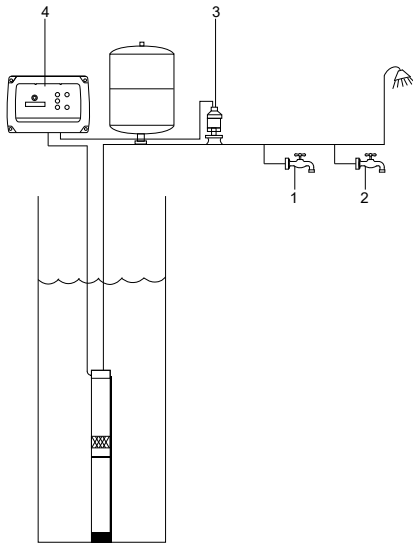

TW089315

Pressure sensor position

Pos.	Description
1	Tap 1
2	Tap 2
3	Pressure sensor
4	CU 302

In the figure above, tap 1 is placed close to the pressure sensor. Therefore, the pressure is kept nearly constant at tap 1, as the friction loss is small. At the shower and tap 2, the friction loss is bigger. This also depends on the pipes. However, old and furred-up pipes can cause inconvenience due to friction loss.

Example:

A person is in the shower. Tap 2 is opened. The increased flow causes pressure loss in the pipe, and even though the controller is keeping the pressure constant at the pressure sensor, the person in the shower feels the pressure loss.

If the pressure sensor is placed closer to the shower tap, the controller increases the pressure when the flow rate is increased. Then the pressure at the shower and tap 2 is kept constant, but the pressure at tap 1 is increased.

We recommend to position the pressure sensor as close to the places of water consumption as possible.

2.10.2 Setting pre-charge pressure

The pre-charge pressure of the diaphragm tank must be set to 70 % of the pressure setting to use the tank to the limit of its capacity. This setting must be used when the tank volume is limited to 8 liters (2 gal).

Use the following values:

Settings for CU 302

Settings [bar]	Pre-charge pressure [bar]
2	1.4
2.5	1.8
3	2.1
3.5	2.5
4	2.8
4.5	3.2
5	3.5

Settings for CU 302 UL

Settings [psi]	Pre-charge pressure [psi]
40	28
50	35
60	42
70	49
80	56
90	63
100	70

If the pre-charge pressure is higher than the pressure setting, the system is not able to control the pressure.

If you want to adjust the pressure without changing the pre-charge pressure of the diaphragm tank, the pre-charge pressure must be equal to the lowest pressure setting used. This means that the control works but that the pressure fluctuations might

increase. In such cases, we recommend to use a larger diaphragm tank, for example, a tank of double size.

2.10.3 Pressure relief valve

To provide protection against the possibility of an overpressurization, a pressure relieve valve must be installed down stream of the well head. The setpoint of the pressure relief valve must be at least 2 bar (30 psi) above the pressure setting.

If a relief valve is installed, we recommend that its outlet is plumbed into an appropriate drainage point.

2.11 Dry-running protection

The purpose of the dry-running protection is to protect the pump in case of insufficient water flow.

When the pump sucks air, the pump power input decreases. If the pump's power input falls below the **Dry-run stop**, power limit value, which is either factory set or set in Grundfos GO, the pump stops and an alarm is activated.

The dry-running protection applies only if the motor speed lies within the maximum speed range, that is, the maximum speed is not less than 1000 rpm. See the figure below.

Normally, the maximum speed is 10,700 rpm.

However, you can reduce the maximum speed by setting **Maximum speed** in Grundfos GO. The **Dry-run stop**, power limit value must match the speed.

In the constant pressure control mode, the dry-running protection is active, as the motor operates at maximum speed in connection with dry-running.

If you use external setpoint or change the **Setpoint** in Grundfos GO, the pump can be forced to run at a reduced speed in relation to the maximum speed. The dry-running protection does not protect the pump if the reduced speed lies outside the maximum speed range, that is, the maximum speed is less than 1000 rpm). See the figure below.

The curve shows the pump power input in relation to the pump speed.

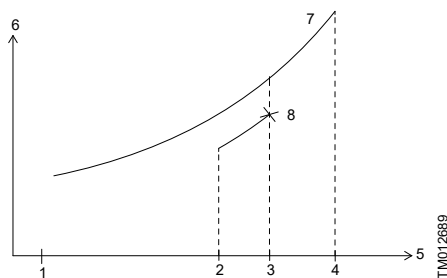

Pump power input curve

Pos.	Description
1	3000 rpm
2	Max. speed -1000 rpm
3	Max. speed as set in Grundfos GO
4	10,700 rpm
5	Motor speed
6	Pump power input [W]
7	Pump power curve
8	Dry-running level set

The **Dry-run stop**, power limit value is factory-set in the SQ/SQE pumps and it depends on the power rating of the actual motor.

Motor size [kW]	Dry-run stop [W]
0.7	300
0.7 (SQ/SQE 2-55)	550
1.15	680
1.55	800
1.85	900

Related information

[11.3 Pump settings](#)

[13.1.10 Code 57 \(Dry running\)](#)

2.12 Built-in protection

The controller offers built-in protection in the following cases:

- **Overpressure**
Overpressure protection is a function that stops the pump and disconnects the power to the pump if the pressure raises 1.5 bar (21.75 psi / 150 kPa) above the setpoint for more than 5 seconds, ensuring that the pump will not continue to operate. When the pressure drops below the setpoint 0.5 bar (7 psi), the pump is connected and started. The event causes an alarm.
The function is not configurable.
- **Low pressure warning**
Operation with reduced pressure is a function that set a warning when the pump is operating at 1 bar below the setpoint for more than 1 minute. This warning indicates water leakage, high water consumption or that the pump is too small for the performance.
The function is not configurable.
- **Low pressure stop**
Low pressure stop is a function that stops the pump if it cannot keep the minimum pressure for a certain time. The pump will restart either automatically or manually based on the configuration.
The function can be changed through Grundfos GO.
See section Application settings for more information.
- **Maximum pressure safety limit**
Maximum pressure safety limit is the maximum allowed pressure for the system set via the operating panel, to avoid unintentionally activating, for example, pressure relief valves or similar equipment.
The function can be changed through Grundfos GO.
See section Application settings for more information.

Related information

[9.1 Constant pressure \(Analog input\)](#)

[9.5 Pressure control \(Analog input\)](#)

[11.2 Application settings](#)

[13.1.26 Code 210 \(Overpressure\)](#)

[13.1.27 Code 211 \(Underpressure\)](#)

3. Receiving the product

3.1 Inspecting the product

Before installation, check the following:

1. Check if the visible parts are damaged.



WARNING

Electric shock

- Death or serious personal injury
- Do not install damaged product.

2. If parts are damaged or missing, contact the local Grundfos sales company immediately.

3.2 Scope of delivery

The box contains the following items:

- controller
- quick guide
- accessories.

3.3 Identification

3.3.1 Nameplate

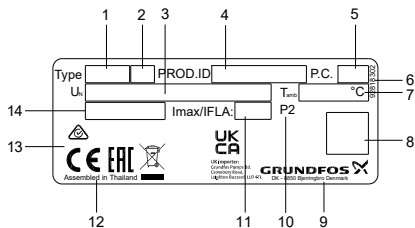

TM084525

Nameplate

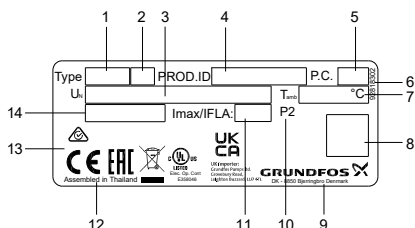

TM086709

Nameplate - UL

Pos.	Description
1	Product name
2	Version number
3	Supply voltage
4	Product number and Serial number
5	Production code (year and week)
6	Nameplate number
7	Minimum to maximum ambient temperature
8	2D data matrix code
9	Company address
10	Factory code
11	Max. current
12	Production site
13	Approvals and markings
14	Enclosure class

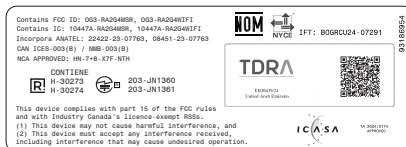

TM087271

Nameplate - radio approvals

Related information

[13.1.6 Code 40 \(Undervoltage\)](#)

4. Installation requirements

WARNING

Electric shock

Death or serious personal injury

- Switch off the power supply before starting any work on the product. Make sure that the power supply cannot be switched on unintentionally.
- Use the recommended fuse size.
- Check that the supply voltage corresponds to the values stated on the nameplate.
- The user or the installer is responsible for correct earthing and protection according to local regulations.



CAUTION

Radiation

Minor or moderate personal injury

- Locate the product at a minimum distance of 20 cm (0.66 ft) from any body parts, to avoid contact with RF energy.



Related information

[16.1 Electrical data](#)

4.1 Location

The controller can be placed both indoors and outdoors.

Install the product in a location that meets the following requirements:

- Make sure that the ambient temperature is within the limits.
- The product must be easily accessible.
- Install the product as close as possible to the connected pumps, sensors, and accessories.
- Place the product in a flood-safe place.
- Make sure the product is not exposed to direct sunlight and rain.



The product must be installed in a place with access control to prevent unauthorized access to the product.

WARNING

Electric shock

Death or serious personal injury

- At altitudes above 2000 m (6561 ft), use overvoltage protection equipment when you install the product.



4.2 Security

4.2.1 RF safety



Installers and end users must be provided with these installation and operating instructions and operating conditions for satisfying RF exposure compliance.

4.2.2 Radio frequency radiation exposure information (for Canada and US only)

CAUTION

Radiation

Minor or moderate personal injury

- This equipment complies with FCC and ICSED radiation exposure limits set forth for an uncontrolled environment. This equipment must be installed and operated with a minimum distance of 20 cm (0.66 ft) between the radiator and your body.



This device complies with Part 15 of the FCC Rules and with Licence exempt RSSs of Innovation, Science & Economic Development Canada.

Operation is subject to the following two conditions:

1. This device may not cause harmful interference, and
2. This device must accept any interference received, including interference that may cause undesired operation.



Changes or modifications made to this equipment not expressly approved by Grundfos may void the FCC authorization to operate this equipment.

4.2.3 EMC statements for USA

Note: This equipment has been tested and found to comply with the limits for a Class B digital device, pursuant to part 15 of the FCC Rules. These limits are designed to provide reasonable protection against harmful interference in a residential installation. This equipment generates, uses and can radiate radio frequency energy and, if not installed and used in accordance with the instructions, may cause harmful interference to radio communications. However, there is no guarantee that interference will not occur in a particular installation. If this equipment does cause harmful interference to radio or television reception, which can be determined by turning the equipment

off and on, the user is encouraged to try to correct the interference by one or more of the following measures:

- Reorient or relocate the receiving antenna.
- Increase the separation between the equipment and receiver.
- Connect the equipment to an outlet on a circuit different from that to which the receiver is connected.
- Consult the dealer or an experienced radio/TV technician for help.

4.2.4 Bluetooth and Wi-Fi information

Bluetooth information

Frequency of operation	2400 - 2483.5 MHz (ISM band)	
Modulation type	GFSK	
Data rate	1 Mbps	
Transmit power	5 dBm EIRP with internal antenna	

Wi-Fi information

Frequency of operation	2400 - 2483.5 MHz (ISM band)	
Modulation type	DSSS	OFDM
Data rate	1 Mbps	72 Mbps
Transmit power	16.05 dBm EIRP with internal antenna	14.15 dBm EIRP with internal antenna



The product must only be connected to protected network subnets with strict access control.

4.2.5 Network interfaces and services

In the factory default state, the product exposes the following network interfaces:

Interface	Description
WiFi	Wireless Ethernet connectivity

In the factory default state, no services are exposed by the product over its network interfaces.

5. Mechanical installation

5.1 Removing the front cover

The front cover must be removed to make any connections.



Use an antistatic service kit when handling electronic components. This prevents static electricity from damaging the components.

Place the front cover above the controller, if possible. This way, you do not need to remove the flat cable between the front cover and the controller.

1. Loosen the screws.
2. Carefully separate the front cover from the back cover.
Be careful not to damage the cable connecting the front cover and the back cover.
3. Place the front cover above the back cover on the support brackets.
4. To ensure that the front cover does not tilt, insert the two bottom screws into the open holes at the top of the back cover.

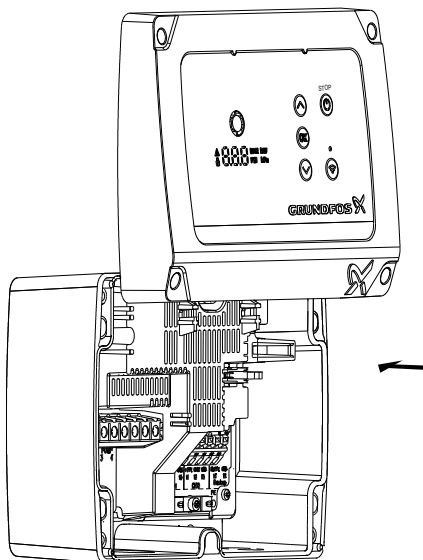

When you mount the front cover again, tighten the screws to 1.25 Nm (0.92 ft-lb).

TM085064

Related information

[5.2 Disconnecting the front cover](#)

[5.3 Installing the controller](#)

[6.4 Connecting a level sensor](#)

5.2 Disconnecting the front cover



Use an antistatic service kit when handling electronic components. This prevents static electricity from damaging the components.

1. Loosen the screws.
2. Carefully separate the front cover from the back cover.

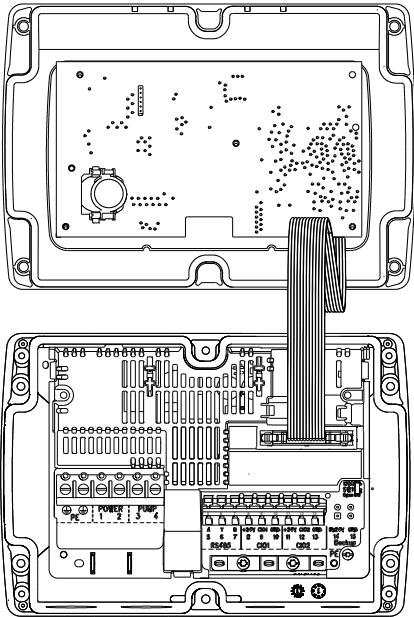

TM084897

3. Flip the locks to the side and pull out the flat cable that is connected to the circuit-board in the back cover.

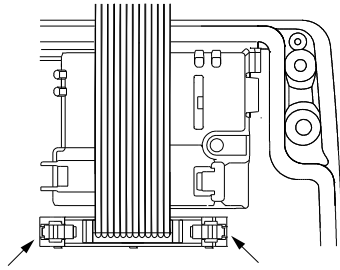

TM086174

Related information

[5.1 Removing the front cover](#)

[5.3 Installing the controller](#)

5.3 Installing the controller

The controller is designed for wall mounting. The cable glands must face downwards.

The box has six mounting holes (Ø4).



Install the controller horizontally on a flat surface to allow any condensed water inside the product to escape.

WARNING

Electric shock

Death or serious personal injury



- The controller is supplied with special inserts for the PG cable entries. The special inserts are suitable for flat cables and single-core cables.
- In addition, cable ties can be used to remove strain from the terminals.

1. Loosen the screws and remove the front cover.
Be careful not to damage the cable connecting the front cover and the back cover.
2. Drill holes in the surface.

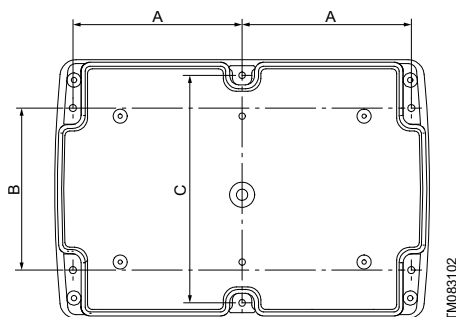

TM083102

Dimensions

Pos.	Description
A	104.5 mm (4.11 in)
B	100 mm (3.94 in)
C	140.5 mm (5.53 in)

3. Insert wall plugs, if applicable.

4. Fit the four screws in the mounting holes and cross-tighten the screws, 1.25 Nm (0.92 ft-lb).



The mounting screws must have a minimum length of 32 mm (Ø 8.2 mm) (1.26 inch (Ø 0.32 inch)). If the wall is more than 3 mm (0.12 inch) uneven, insert rubber blocks between the surface and the controller to even the surface.



The box of the controller must not be bent.

Related information

- [5.1 Removing the front cover](#)
- [5.2 Disconnecting the front cover](#)

5.4 Mounting the rubber seals

1. Mount the rubber seals on the cable glands.

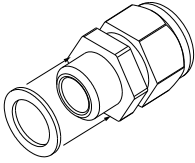

TM074473

2. Mount the cable glands on the controller.

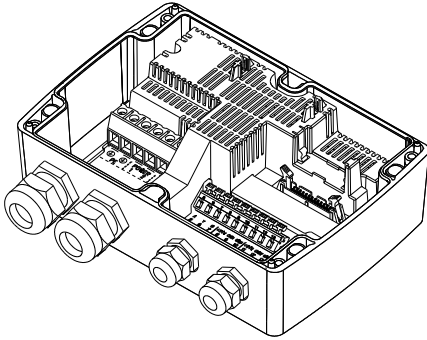

TM085063

3. Tighten both the cable glands and the orbits to the correct torque. See the tables below.



Do not tighten the cable glands too much since this may damage the rubber seals.

CU 302

Cable gland type	Torque [Nm (ft-lb)]
2 × PG21	2.5 (1.84)
2 × PG11	

CU 302 UL

Cable gland type	Torque [Nm (ft-lb)]
2 × PG11	2.5 (1.84)
2 × 1/2 inch conduit hubs ¹⁾	

For UL variants only:

In installations using conduit hubs, only use conduit hub compression connector for unthreaded openings with a nominal knockout diameter of 22.23 mm (0.875 inch).

Connect the conduit hub to the conduit before you connect the conduit hub to the enclosure.

To secure proper tightening between the conduit hub compression connector and the bottom part of the controller, the conduit hub compression connector and the nut must not be tightened more than 2.5 Nm (1.84 ft-lb).



- ¹⁾ Not delivered with the controller. Can be purchased separately.

Related information

[5.5 Accessories in the cable gland set](#)

[16.4 Dimensions](#)

5.5 Accessories in the cable gland set

Accessory	CU 302	CU 302 UL	Description
 TM0065844	•	-	If the outer diameter of a round power or motor cable is in the range up to 7 to 10 mm (0.27 to 0.39 inch), put the reduction seal ring on the cable and then insert it in the PG21 cable gland. Tighten the PG21 cable gland correctly.
 TM0065843	•	-	Use the flat cable seal ring in the PG21 cable gland if the SQE or the SQFlex pump flat cable is inserted directly in the controller. Put the flat cable sealing on the cable and then insert it in the PG21 cable gland. Tighten the PG21 cable gland correctly.
 TM0065842	•	•	If not all PG11 cable glands are used, insert the flat head sealing plug in the open PG11 cable gland before tightening it. Tighten the PG11 cable gland correctly to secure a tight controller.

Related information

[5.4 Mounting the rubber seals](#)

5.6 Removing the screw (UL variants only)



The instructions in this section are only applicable for UL variants.

1. Remove the screw from the bottom of the box for Nema 3R applications. Keep the screw in the bottom of the box for other, Type 1 applications.

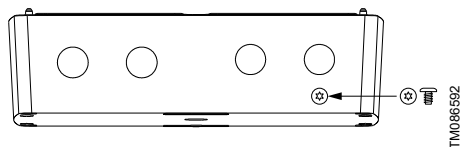

6. Electrical connection



WARNING

Electric shock

Death or serious personal injury

- Switch off the power supply before starting any work on the product. Make sure that the power supply cannot be switched on unintentionally.



DANGER

Electric shock

Death or serious personal injury

- In case of an insulation fault, the fault current may be a DC or pulsating DC. Observe national legislation about requirements for and selection of Residual Current Device (RCD) when installing the product.

6.1 Cable requirements



WARNING

Electric shock

Death or serious personal injury

- The wires from the pump phases must be rated at 90 °C (194 °F).



For the US market only, use flexible metal conduits (FMC).



Changes or modifications not specifically approved by Grundfos may void the user's authority to operate the equipment.

Wire type	Wire size	
	[mm ²]	[AWG]
Power wire	min. 1.5	min. 16
Pump wire	2.5 - 16	14-6
Terminals 5 to 15 wires	0.25 - 1.5	24-16



WARNING

Electric shock

Death or serious personal injury

- The power cable must be installed or repaired by a qualified electrician.

Cable diameters for CU 302

Cable type	Cable diameter
Through the PG11 cable glands	5-10 mm (0.2 - 0.4 inch)
Through the PG21 cable glands	10-18 mm (0.4 - 0.7 inch)

Cable diameters for CU 302 UL

Cable type	Cable diameter
Through the PG11 cable glands	5-10 mm (0.2 - 0.4 inch)
Through the 1/2 inch conduit hubs ²⁾	Wires in conduits according to local regulations in the range of AWG 14-6.

²⁾ The 1/2 inch conduit hubs are not delivered with the controller. They can be purchased separately.

Cable length

Pump cable	Maximum length between the controller and the pump: 300 m (984 ft).
RS-485 cable	The length of the cable for RS-485 input: 1200 m (3937 ft).
Cables on the IO ports	The length of the cable must ensure that the input signals meet the data in section Electrical data.

Related information

[6.3 Connecting the pump supply and power supply](#)

[16.1 Electrical data](#)

[16.4 Dimensions](#)

6.2 Protection of controller and supply cables

To protect the controller and power cables against short-circuit and overload, use the following:

- fuse of melt type gL and gG
- fuse type gD
- circuit breaker of type C.

See the rated current for this specific product on the product nameplate.

6.2.1 Voltage transient protection

Transients and surges normally seek the path to the ground with the least resistance to the earth or ground. Groundwater is a good conductor for this path, especially when used with submersible pumps.

The electronic controllers have built-in electronics, which is designed to withstand transients higher than 4000 V. However, lightning, surges, and transients can generate voltages that exceed this level, therefore additional transient protection is recommended to protect the submersible pump properly. Especially installations in areas with:

- occasional power loss
- electronic controlled equipment as VFD and other switching devices
- arcing contacts
- lightning or thunderstorms.

The protection must work correctly to ensure proper grounding connection either via metal well casing or grounding rod.

Transient protection is not designed to protect against direct lightning hits. The device wears out by activation and would need replacement to maintain protection.

Suggested solution specifications:

- **Medium protection level:** protection against transient as indirect lightning and surges (IEC 61643-1 Arrester class II, 8 μ s / 20 μ s pulse, 15 kA peak current)

6.3 Connecting the pump supply and power supply

DANGER

Electric shock

Death or serious personal injury



- In case of an insulation fault, the fault current may be a DC or pulsating DC. Observe national legislation about requirements for and selection of Residual Current Device (RCD) when installing the product.

DANGER

Electric shock

Death or serious personal injury



- Switch off the power supply before starting any work on the product. Make sure that the power supply cannot be switched on unintentionally.
- Remember to indicate where the main switch is located by placing a label or similar marking on the controller.
- Make sure that the input voltage does not exceed 240 VAC.
- Electrical connections must be carried out according to the wiring diagrams.



Do not add additional components other than those illustrated on the wiring diagram. Do not use unused pin holes for other connections.



All cable glands and plugs must be mounted after the installation is completed.

If the gaskets are not pre-mounted on the cable glands, mount them on the cable glands before the controller is mounted on the wall.

1. Check that the supply voltage and frequency correspond to the values stated on the nameplate.
2. Cut the power supply and pump cables as short as possible.
3. Before switching the power on, check all voltages with a multimeter and make sure that the input voltage does not exceed 240 VAC.

4. Connect the power cables and pump cables according to the relevant electrical diagram.



All cable glands must be mounted and plugged to ensure the correct IP protection level.

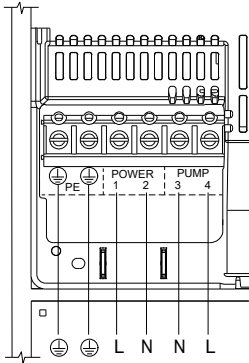

Single-phase connections for the pump

POWER, terminals 1, 2 and PE

- Connect terminals 1 and 2 to the phase and neutral conductors of the mains supply. Each terminal can be connected to any of the two conductors.
- Connect the PE terminal to the green and yellow earth conductor. Each PE terminal must be connected to an earth conductor of its own.



IEC 60417-5019 (2006-08)



The conductors of the mains supply must not be connected to terminals 3 and 4 (PUMP).

PUMP, terminals 3, 4 and PE

- Connect terminals 3 and 4 to the phase and neutral conductor of the pump. Each terminal can be connected to any of the two conductors.
- Connect the PE terminal to the green and yellow earth conductor. Each PE terminal must be connected to an earth conductor of its own.



IEC 60417-5019 (2006-08)

5. Tighten the terminal screws to the correct torque. See the table below.

Terminal block	Torque [Nm (ft-lb)]
Pump supply	1.2 - 1.5 (0.88 - 1.1)
Power supply	1.2 - 1.5 (0.88 - 1.1)

6. Tie the wires with cable ties.

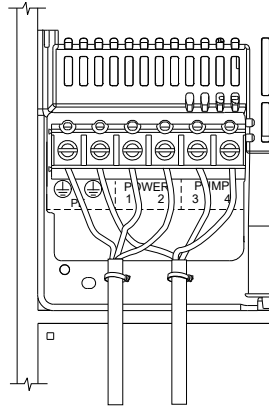

Related information

- [6.1 Cable requirements](#)
- [6.6 Terminal blocks](#)
- [16.1 Electrical data](#)

6.4 Connecting a level sensor

You can either connect a digital level switch, such as a float switch, or an analog level sensor.

- Loosen the screws and remove the front cover.
Be careful not to damage the cable between the front cover and the back cover.
- Lead the wires through one of the cable glands.
- Push the arm down to open the spring clamp terminal and then insert the wire.

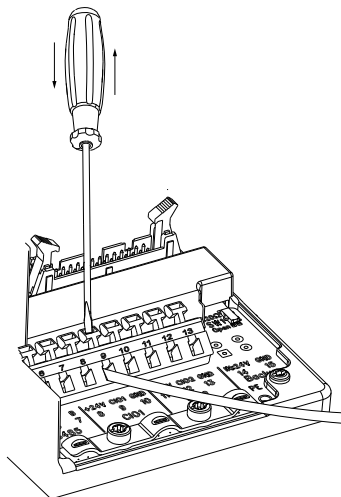

Connecting a wire to a terminal with spring clamps

- Depending on the type of wire, take one of the following actions:
 - For a shielded wire, lead it through the cable clamp.

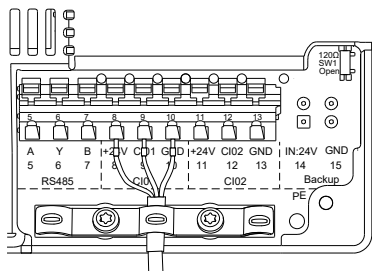

- For a not shielded wire, attach it directly to the terminals, the earth wire can be connected to the metal earth bracket.

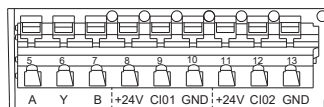

A	GENibus A
Y	GENibus Y
B	GENibus B

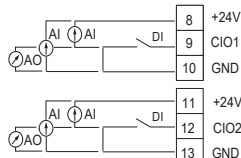

TM083679

Terminal	Description
5	RS-485 interface A for GENibus/Modbus
6	GND, Y for GENibus/Modbus
7	RS-485 interface B for GENibus/Modbus
8	Supply voltage, +24 V
9	Configurable input/output 1 ³⁾
10	GND ³⁾
11	Supply voltage, +24 V
12	Configurable input/output 2 ⁴⁾
13	GND ⁴⁾

- Connect the float switch or sensor cables according to the relevant electrical diagram.
- Default setup: Float switch (start/stop), normally open.
- Default setup: Pulse flow

Related information

- [5.1 Removing the front cover](#)
- [6.7 Sensor input](#)

6.5 RS-485 input and output

RS-485, terminals 5, 6 and 7

The RS-485 input, terminals A, Y (GND) and B, is for external bus communication.

This is a two-way communication, which is effected according to the Grundfos bus protocol, GENibus.

TM083901

TM083677

The RS-485 input can be changed to Modbus protocol via Grundfos GO for third party connection. The RS-485 input is a low-voltage circuit. Therefore, you must separate all connections to terminals A, Y (GND) and B from network circuits by means of double or reinforced insulation.

A screened twisted-pair cable is required and the screen must be connected to a common reference at both ends. The maximum cable length is 1200 m (3937 ft).

6.6 Terminal blocks

The controller has two terminal blocks:

- Screw terminals 1 to 4.
- Spring terminals 5 to 13.

The controller is also equipped with two screw terminals for the protective-earth conductors (PE).



IEC 60417-5019 (2006-08)

TM086082

The ON/OFF button on the controller must not be used as a safety switch when installing and servicing the pump.

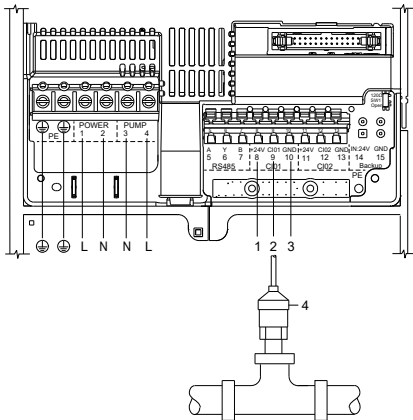

TM083103

Electrical connection

Pos.	Description
1	Standard pressure sensor. + 24 VDC, brown conductor, terminal 8.
2	Standard pressure sensor. Input signal, black conductor, terminal 9.
3	Standard pressure sensor. Screen, terminal 10.
4	Standard pressure sensor.

Related information

[6.3 Connecting the pump supply and power supply](#)

[16.1 Electrical data](#)

6.7 Sensor input

DANGER

Electric shock

Death or serious personal injury



- The total load of terminals 8 and 11, +24 VDC, must not exceed 300 mA.
- Any power supply connected to the 24 V backup terminals must have double or reinforced insulation towards other circuits.

CIO1, terminals 8, 9 and 10

Terminals 8, 9 and 10 (CIO1) are used for the pressure sensor. The terminal can also be used for analog and digital inputs or as configurable analog or digital outputs.

Sensor signals:

The connected sensor must give signals within one of the following ranges:

- 0.5 V
- 0.5 - 3.5 V
- 0-10 V
- 0-20 mA
- 4-20 mA

Changeover between current and voltage signals is carried out by means of Grundfos GO.

CIO2, terminals, 11, 12 and 13

Terminals 11, 12 and 13 (CIO2) are set up as pulse flow input by default. The terminal can also be used for analog and digital inputs or as configurable analog or digital outputs.

Related information

[6.4 Connecting a level sensor](#)

7. Control functions

7.1 Operating panel

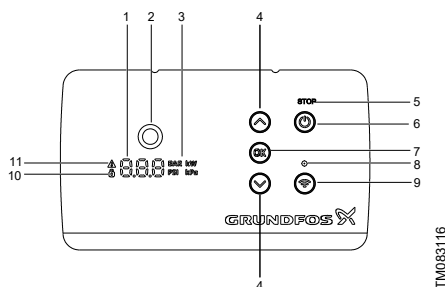

Pos.	Symbol	Description
1		Display
2		Grundfos Eye: The Grundfos Eye shows the status of the pump.
3	BAR kW PSI kPa	Units
4		Up/Down buttons: <ul style="list-style-type: none"> Press these buttons to navigate between submenus or change the value settings.
5	STOP	STOP LED: If the text is lit, the pump is stopped.
6		Stop button <ul style="list-style-type: none"> Press this button to stop the pump.
7	OK	OK button: <ul style="list-style-type: none"> Press this button to save changed values.
8		Connect symbol: If the symbol is lit, the controller is connected to Grundfos GO.
9		Connect button: <ul style="list-style-type: none"> Press this button to connect the controller to Grundfos GO via Bluetooth.
10		Lock symbol: If the symbol is lit, the controller is locked from making changes.
11		Alarm and warning symbol: Red: Alarm Yellow: Warning

The controller enables manual setting and monitoring of the system.

By pressing the **Up** and **Down** buttons, you can read and adjust the displayed values on the operating panel.











Information order	Displayed value	Description
0	50 psi	Pressure setpoint
1	P 50 psi	Pressure measurement
2	U 230	Voltage - pump
3	A 8.4	Current - pump
4	Err 057	Error code / Warning code (optional)

By pressing the **OK** button for 3 seconds, you can adjust the setpoint with the **Up** and **Down** buttons. The setpoint can be adjusted in steps of 0.5 bar or 5 psi or 50 kPa. To confirm the set setpoint, press the **OK** button.

Related information

[7.2 Grundfos Eye](#)

7.2 Grundfos Eye

Indicator light	Alarm and warning symbol	Indication	Description
		No lights are on.	Power off The pump is not running.
		Two opposite green lights are running in the pumping direction.	Power on The pump is running.
		Two opposite green lights are permanently on.	Power on The pump is not running.
		One yellow light is running in the pumping direction.	Warning The pump is running.
		One yellow light is permanently on.	Warning The pump has been stopped manually.
		One red light is running in the pumping direction.	Alarm The pump is running.
		Two opposite horizontal red lights are flashing simultaneously.	Alarm The pump has stopped.

Related information

[7.1 Operating panel](#)

8. Starting up the product

8.1 Connecting to Grundfos GO

Before connecting the product to Grundfos GO, the Grundfos GO app must be downloaded to your smartphone or tablet. The app is free and available for iOS and Android devices.

The connection can be started either from the operating panel or Grundfos GO. If multiple products are installed, start the connection at the operating panel.

1. Open Grundfos GO. Make sure that Bluetooth is enabled.
Your device must be within reach of the product to establish Bluetooth connection.
2. Go to the **Remote** menu in Grundfos GO.
3. To start the connection from the operating panel, go to step 4.
To start the connection from Grundfos GO, go to step 5.
4. To start the connection from the operating panel:
 - a. Press the connect icon on the operating panel.
The blue LED above the connect icon is flashing until your device is connected.
 - b. Press **CONNECT** in the top bar in Grundfos GO next to the message **CU 302 wants to connect**.
5. To start the connection from Grundfos GO:
 - a. Press the connect icon in Grundfos GO.
 - b. Press **CONNECT** for the controller in the **Connect** menu.
 - c. Press the connect icon on the operating panel.
The blue LED above the connect icon is flashing until your device is connected.

Once the connection is established, the LED is permanently on.

Grundfos GO is now loading the data for the product.

Related information

[8.2 How to enable Bluetooth on the operating panel](#)

[8.3 How to disable Bluetooth on the operating panel](#)

[11.6.2 Updating the software](#)

8.2 How to enable Bluetooth on the operating panel

Grundfos GO cannot be connected without Bluetooth connection.

1. Press and hold the connect button on the operating panel for 15 seconds. Wait for the blue LED to light up.
2. To start the connection, follow the steps in section [Connecting to Grundfos GO](#).

Related information

[8.1 Connecting to Grundfos GO](#)

8.3 How to disable Bluetooth on the operating panel

In some installation areas, it is not allowed to have a Bluetooth signal enabled during operation. After installation, the Bluetooth signal must be disabled manually.

1. Press and hold the connect button on the operating panel for 15 seconds. Wait for the blue LED to switch off.
Grundfos GO is no longer connected to the product.

Related information

[8.1 Connecting to Grundfos GO](#)

9. Control modes

You can select one of the following control modes:

- **Constant pressure**
- **Level control - Filling**
- **Level control - Emptying**
- **Pressure control**
- **Pump out**
- **Pump monitoring**

You can set the control mode with Grundfos GO.

Related information

[10.9 Control mode](#)

[11.2 Application settings](#)

9.1 Constant pressure (Analog input)

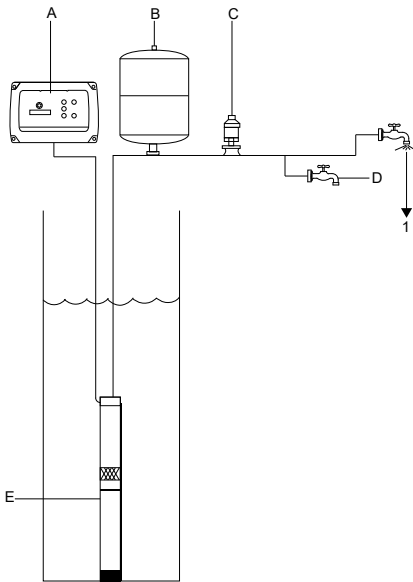

TM087680

Pos.	Description
1	Water flow
A	CU 302
B	Diaphragm tank
C	Pressure sensor
D	Tap
E	SQE pump

The system maintains a constant pressure within the maximum pump performance in spite of a varying water consumption. The pressure is registered by

means of the pressure sensor, which transmits a signal to the controller. The controller adjusts the pump performance accordingly to maintain a constant pressure by changing the pump speed.

The performance of the pump follows the selected constant pressure curve. The selection of the constant pressure setting depends on the characteristics of the system and the actual water demand. See section System limits.

Setting **Constant pressure** with Grundfos GO:

1. Go to **Settings > Application settings > Control mode**.
2. Select **Constant pressure**.
3. Press **Edit** to set the parameters.
4. Select **Input type**.
Default value: **Analog input**.
5. Select **Configurable I/O**.
Default value: **CIO 1**.
6. Select **Electrical signal type**.
Default value: 4-20 mA.
7. Select pressure unit.
Default value for CU 302: **bar**.
Default value for CU 302 UL: **psi**.
8. Set **Sensor range (min)**.
Default value: 0 bar (0 psi).
9. Set **Sensor range (max)**.
Default value: 6 bar (120 psi).
10. Set **Maximum pressure safety limit**.
Value range: 0-5 bar (0-100 psi).
Default value: 5 bar (70 psi).
11. Set **Setpoint**.
Value range: 2-5 bar (28-100 psi).
Default value: 3 bar (50 psi).
12. Optionally, set the following parameters in **Application settings** menu:
 - **Stop functions**
 - **PID Controller**
 - **Diaphragm tank size**
 - **Manual PID controller**
 - **Low pressure stop**
 - **Max run time**
 - **Unit configuration**
Default value for CU 302: **bar**.
Default value for CU 302 UL: **psi**.

Related information

- [2.8 System limits](#)
- [2.12 Built-in protection](#)
- [10.8 Setpoint](#)
- [11.2 Application settings](#)
- [13.1.14 Code 89 \(Signal fault, \(feedback\) sensor 1\)](#)
- [13.1.21 Code 197 \(Constant pressure: Low pressure\)](#)
- [13.1.24 Code 200 \(Constant pressure: Max run time\)](#)
- [13.1.26 Code 210 \(Overpressure\)](#)
- [13.1.27 Code 211 \(Underpressure\)](#)

9.2 Level control - Filling

9.2.1 Level control Filling (1 Digital input)

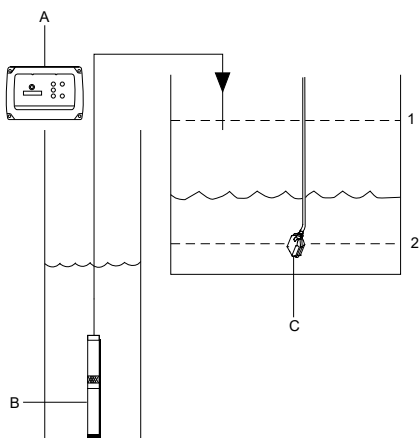

TM0834 16

Pos.	Description
1	Stop level
2	Start level
A	CU 302
B	SQE pump
C	Float switch

In the filling application, the pump is installed in a tank or well from where it pumps the water. The water is pumped into the filling tank where the float switch is installed.

The pump starts to fill the tank when **Start level** is reached.

The pump stops when the water level reaches **Stop level**.



If required, set a start and stop delay. This will prevent the pump from starting and stopping too frequently.

Setting **Level control Filling (1 Digital input)** with Grundfos GO:

1. Go to **Settings > Application settings > Control mode**.
2. Select **Level control Filling**.
3. Press **Edit** to set the parameters.
4. Select **Input type**.
Default value: **Digital input**.
5. Select **Configurable I/O**.
Default value: **CIO 1**.
6. Select **Contact type**.
Default value: **Normally open**.
7. Press **Save** to save your settings.
8. Optionally, set the following parameters in **Application settings** menu:
 - **Start delay**
Default value: **Disabled**.
 - **Stop delay**
Default value: **Disabled**.
 - **Signal detection time**
Default value: **0 s**.

Related information

- [11.2 Application settings](#)

9.2.2 Level control Filling (Analog input)

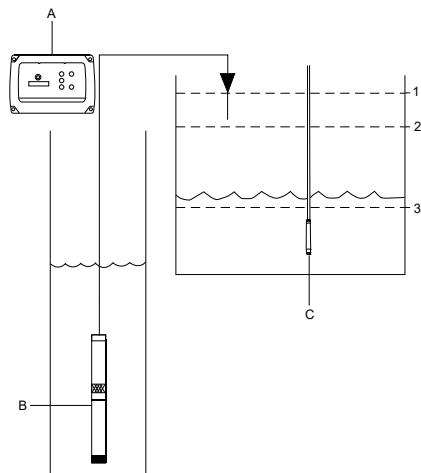

TM086216

Pos.	Description
1	High level
2	Stop level
3	Start level
A	CU 302
B	SQE pump
C	Analog sensor

In the filling application, the pump is installed in a tank or well from where it pumps the water. The water is pumped into the filling tank where an analog sensor is installed.

The pump starts to fill the tank when **Start level** is reached.

The pump stops when the water level reaches **Stop level**.

If **High level** is reached, an alarm indicates that the critical level is reached and the pump is stopped.

Setting **Level control Filling (Analog input)** with Grundfos GO:

- Go to **Settings > Application settings > Control mode**.
- Select **Level control Filling**.
- Press **Edit** to set the parameters.
- Select **Input type**.
Default value: **Analog input**.
- Select **Configurable I/O**.
Default value: **CIO 1**.

- Select **Electrical signal type**.
Default value: 4-20 mA.
- Select level unit.
Default value: **m**.
- Set **Sensor range (min)**.
Default value: 0 m.
- Set **Sensor range (max)**.
Default value: 10 m.
- Set **High level**.
Value range: 0-10 m.
Default value: 5 m.
- Set **Stop level**.
Value range: 0-10 m.
Default value: 4 m.
- Set **Start level**.
Value range: 0-10 m.
Default value: 2 m.
- Press **Save** to save your settings.
- Optionally, set the following parameters in **Application settings** menu:
 - Start delay**
Default value: **Disabled**.
 - Stop delay**
Default value: **Disabled**.
 - Signal detection time**
Default value: 0 s.

Related information

[11.2 Application settings](#)

9.3 Level control - Emptying

9.3.1 Level control Emptying (1 Digital input)

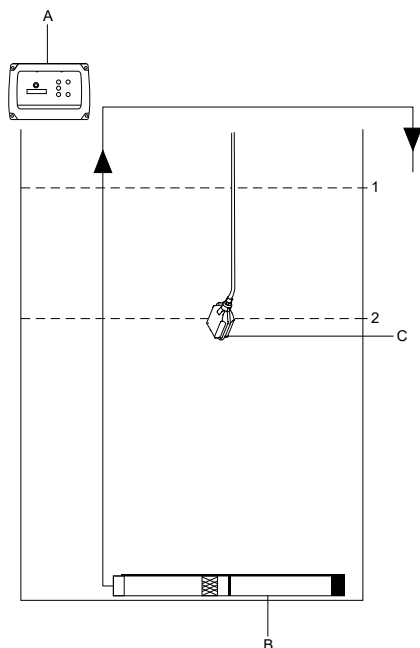

TM096217

Pos.	Description
1	Start level
2	Stop level
A	CU 302
B	SQE pump
C	Float switch

The pump starts to empty the tank or well when **Start level** is reached.

The pump stops when the water level is lowered to **Stop level**.

Setting **Level control Emptying (1 Digital input)** with Grundfos GO:

1. Go to **Settings > Application settings > Control mode**.
2. Select **Level control Emptying**.
3. Press **Edit** to set the parameters.
4. Select **Input type**.
Default value: **Digital input**.
5. Select **Configurable I/O**.
Default value: **CIO 1**.
6. Select **Contact type**.
Default value: **Normally closed**.
7. Press **Save** to save your settings.
8. Optionally, set the following parameters in **Application settings** menu:
 - **Start delay**
Default value: **Disabled**.
 - **Stop delay**
Default value: **Disabled**.
 - **Signal detection time**
Default value: **0 s**.

Related information

[11.2 Application settings](#)

9.3.2 Level control Emptying (Analog input)

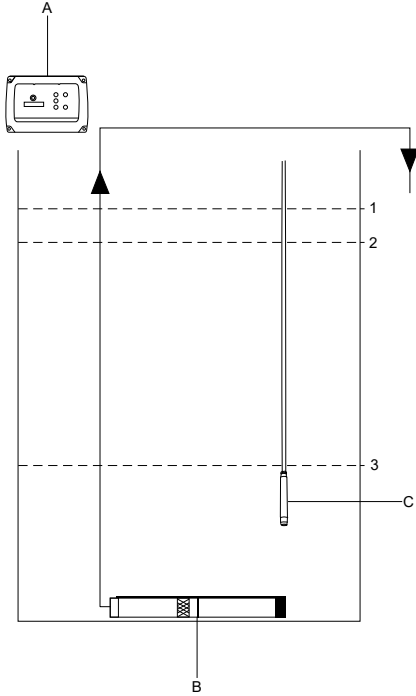

TM083415

Pos.	Description
1	High level
2	Start level
3	Stop level
A	CU 302
B	SQE pump
C	Analog sensor

The pump starts to empty the tank or well when **Start level** is reached.

The pump stops when the water level is lowered to **Stop level**.

If **High level** is reached, an alarm indicates that the critical level is reached.

If the pump is running and the water level in the tank or well falls below **Stop level**, the pump's built-in sensor stops the pump to ensure it is not damaged.

Setting **Level control Emptying (Analog input)** with Grundfos GO:

- Go to **Settings > Application settings > Control mode**.
- Select **Level control Emptying**.
- Press **Edit** to set the parameters.
- Select **Input type**.
Default value: **Analog input**.
- Select **Configurable I/O**.
Default value: **CIO 1**.
- Select **Electrical signal type**.
Default value: 4-20 mA.
- Select level unit.
Default value: **m**.
- Set **Sensor range (min)**.
Default value: 0 m.
- Set **Sensor range (max)**.
Default value: 10 m.
- Set **High level**.
Value range: 0-10 m.
Default value: 5 m.
- Set **Start level**.
Value range: 0-10 m.
Default value: 4 m.
- Set **Stop level**.
Value range: 0-10 m.
Default value: 2 m.
- Press **Save** to save your settings.
- Optionally, set the following parameters in **Application settings** menu:
 - Start delay**
Default value: **Disabled**.
 - Stop delay**
Default value: **Disabled**.
 - Signal detection time**
Default value: 0 s.

Related information

[11.2 Application settings](#)

9.4 Pressure control (Digital input)

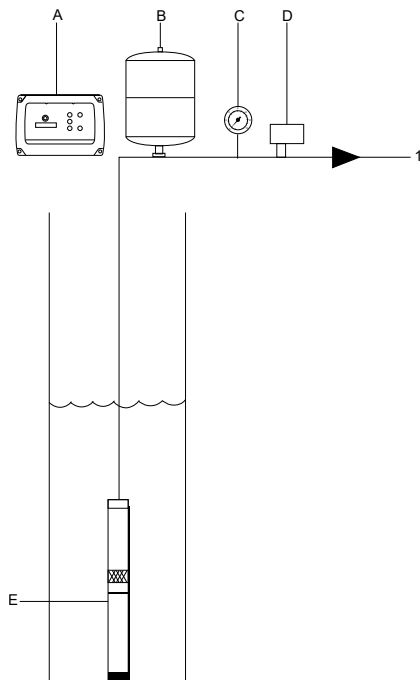

TM086686

Pos.	Description
1	Water flow
A	CU 302
B	Diaphragm tank
C	Pressure gauge
D	Pressure switch
E	SQE pump

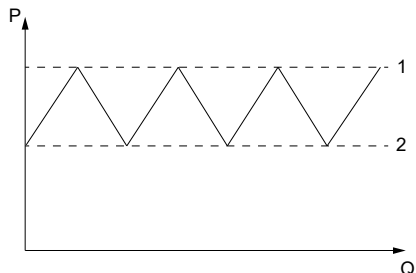

TM086687

Pressure variations

Pos.	Description
1	Stop Pressure
2	Start Pressure
Q	Flow
P	Pressure

The pump starts to run to keep the pressure when **Start Pressure** is reached.

The pump stops when the pressure is at or higher than **Stop Pressure**.

Setting **Pressure control** with Grundfos GO:

- Go to **Settings > Application settings > Control mode**.
- Select **Pressure control**.
- Press **Edit** to set the parameters.
- Select **Input type**.
Default value: **Digital input**.
- Select **Configurable I/O**.
Default value: **CIO 1**.
- Select **Contact type**.
Default value: **Normally closed**.
- Press **Save** to save your settings.
- Optionally, set the following parameters in **Application settings** menu:
 - **Max run time**
Default value: **Disabled**.
 - **Start delay**
Default value: **Disabled**.
 - **Stop delay**
Default value: **Disabled**.
 - **Signal detection time**
Default value: 0 s.
 - **Unit configuration**
Default value for CU 302: **bar**.
Default value for CU 302 UL: **psi**.

Related information

[11.2 Application settings](#)

[13.1.23 Code 200 \(Pressure control: Max run time \(Max\)\)](#)

9.5 Pressure control (Analog input)

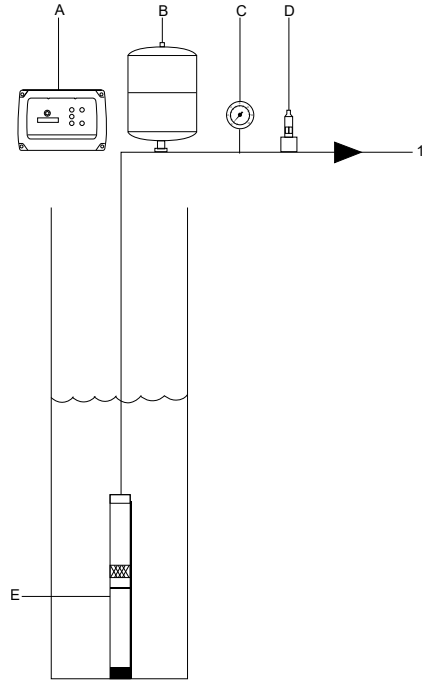

Pos.	Description
1	Water flow
A	CU 302
B	Diaphragm tank
C	Pressure gauge
D	Pressure sensor
E	SQE pump

TM086218

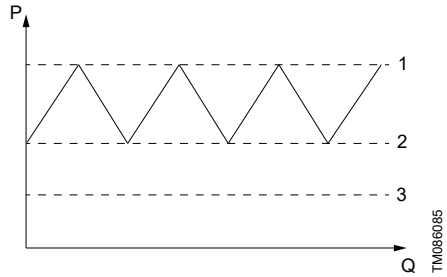

TM086085

Pressure variations

Pos.	Description
1	Stop Pressure
2	Start Pressure
3	Low pressure stop (optional)
Q	Flow
P	Pressure

The pump starts to run to keep the pressure when **Start Pressure** is reached.

The pump stops when the pressure is at or higher than **Stop Pressure**.

If **Low pressure stop** is enabled and reached, an alarm sets off and stops the pump. The system automatically restarts the pump after a predefined restart time.

Maximum pressure safety limit is the maximum allowed pressure for the system set via the operating panel, to avoid unintentionally activating, for example, pressure relief valves or similar equipment. The function can be changed through Grundfos GO.

Setting **Pressure control** with Grundfos GO:

- Go to **Settings > Application settings > Control mode**.
- Select **Pressure control**.
- Press **Edit** to set the parameters.
- Select **Input type**.
Default value: **Analog input**.
- Select **Configurable I/O**.
Default value: **CIO 1**.
- Select **Electrical signal type**.
Default value: 4-20 mA.
- Select pressure unit.
Default value for CU 302: **bar**.
Default value for CU 302 UL: **psi**.

8. Set **Sensor range (min)**.
Default value: 0 bar.
9. Set **Sensor range (max)**.
Default value: 10 bar.
10. Set **Maximum pressure safety limit**.
Value range: 0-10 bar.
Default value: 5 bar.
11. Set **Stop Pressure**.
Value range: **Sensor range (min) - Maximum pressure safety limit**.
Default value: 3 bar.
12. Set **Start Pressure**.
Value range: **Sensor range (min) - Maximum pressure safety limit**.
Default value: 2 bar.
13. Press **Save** to save your settings.
14. Optionally, set **Low pressure stop**, see section **Application settings**.
Low pressure stop is disabled by default.
15. Optionally, set the following parameters in **Application settings** menu:
 - **Max run time**
Default value: **Disabled**.
 - **Start delay**
Default value: **Disabled**.
 - **Stop delay**
Default value: **Disabled**.
 - **Signal detection time**
Default value: 0 s.
 - **Unit configuration**
Default value for CU 302: **bar**.
Default value for CU 302 UL: **psi**.

Related information

[2.12 Built-in protection](#)

[11.2 Application settings](#)

[13.1.23 Code 200 \(Pressure control: Max run time \(Max\)\)](#)

9.6 Pump out

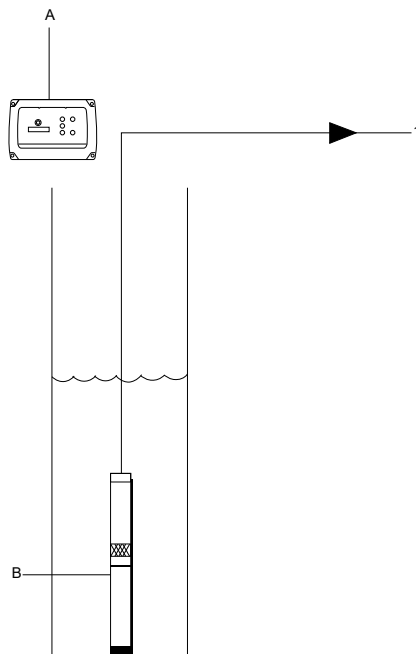

TM086219

Pos.	Description
1	Open discharge
A	CU 302
B	SQE pump

In the **Pump out** control mode, the pump is installed in a well. In case of newly drilled wells, clean it by pumping for a few hours before connecting it to the pipe system.

The pump starts to run when the ON/OFF button is pushed and it will run until the defined **Pumping time** has elapsed. Then the controller resumes the previous control mode.

If the operation of the pump is interrupted, it stops and resumes with the previous control mode. To start the pump, push the ON/OFF button.

The configurable I/O ports are disabled by default. It is not recommended to enable them as it can cause interruption of the **Pump out** control mode.

Setting **Pump out** with Grundfos GO:

1. Go to **Settings > Application settings > Control mode**.
2. Select **Pump out**.
3. Press **Edit** to set the parameters.
4. Set **Pump speed**.
The pump speed is relative to the maximum speed.
Value range: 30-100 %.
Default value: 75 %.
5. Set **Pumping time**.
Value range: 0-99 h.
Default value: 1 h.
6. Press **Save** to save your settings.

Related information

[11.2 Application settings](#)

[13.1.22 Code 200 \(Pump Out interrupted \(Pump\)\)](#)

9.7 Pump monitoring

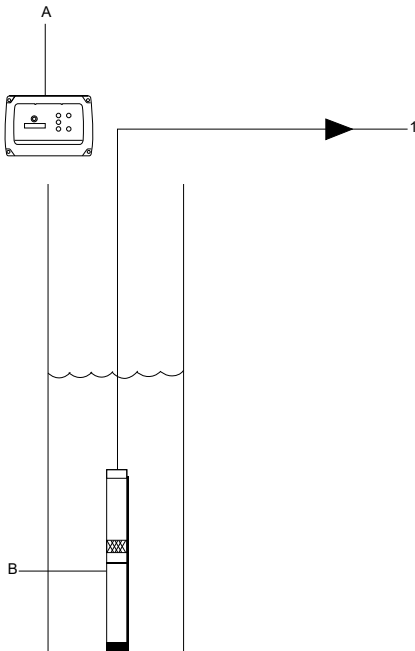

TM086219

Pos.	Description
1	Open discharge
A	CU 302
B	SQE pump

In the **Pump monitoring** control mode, the pump is installed in a well or tank. The controller monitors the pump and can also use CIO ports for measurements, for example, water level etc.

The pump starts to run when the ON/OFF button is pushed.

The configurable I/O ports are disabled by default. You can enable and configure them according to the connected devices.

Setting **Pump monitoring** with Grundfos GO:

1. Go to **Settings > Application settings > Control mode**.
2. Select **Pump monitoring**.
3. Press **Save** to save your settings.

The CIO port is disabled by default.

10. Grundfos GO dashboard

When the controller is connected to Grundfos GO, the application displays the dashboard of the product.

The dashboard consists of several parts that display information based on the control mode selected.

The default control mode is **Constant pressure**.

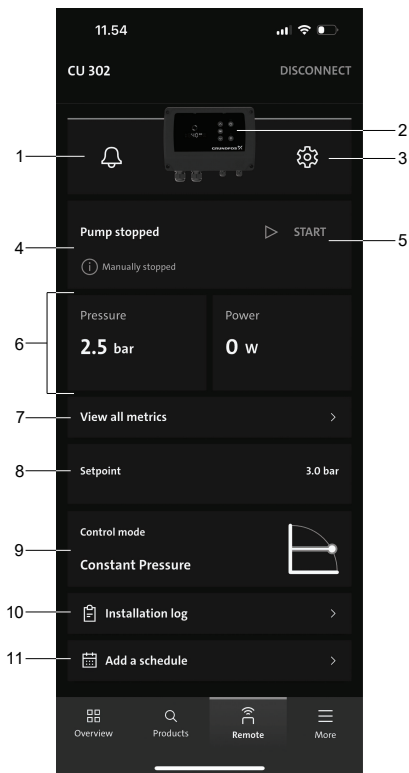

TM088780

Example of the dashboard

Pos.	Description
1	Event notifications
2	Product information
3	Settings
4	Pump status and state
5	Start/stop the control mode
6	Control mode metrics
7	View all metrics
8	Setpoint

Pos.	Description
9	Control mode
10	Installation log
11	Scheduling

For information about each part of the dashboard, see the sections below.

Related information

- [10.1 Event notifications](#)
- [10.2 Product information](#)
- [10.3 Settings](#)
- [10.4 Pump status and state](#)
- [10.5 Start/stop the control mode](#)
- [10.6 Control mode metrics](#)
- [10.7 View all metrics](#)
- [10.8 Setpoint](#)
- [10.9 Control mode](#)
- [10.10 Installation log](#)
- [10.11 Scheduling](#)

10.1 Event notifications

On the dashboard, the bell icon indicates if any controller- or pump-related events occur. Press the bell icon to see the current and past events.

The following event types can be displayed:

- notifications
- warnings
- alarms.

Press an event to see details about it.

Related information

- [10. Grundfos GO dashboard](#)
- [11.6.2 Updating the software](#)
- [13. Fault finding](#)

10.2 Product information

On the dashboard, press the picture of the controller to display additional product information, such as, product number, serial number, software version and so on.

Related information

- [10. Grundfos GO dashboard](#)

10.3 Settings

On the dashboard, press the wheel icon to display the **Settings** menu.

See section Setting the product for more information.

Settings	
Application settings	
Product name	
Control mode	
Setpoint	
Maximum pressure safety limit	
Cut-in speed	
Stop functions	
<ul style="list-style-type: none"> • PID Controller <i>Application settings</i> ⁵⁾ <ul style="list-style-type: none"> - Diaphragm tank size - Manual PID controller • Low pressure stop • Max run time 	
Unit configuration	
Configurable Input/Output	
<ul style="list-style-type: none"> • Configurable I/O 1 • Configurable I/O 2 	
Pump settings	
Maximum speed	
Minimum speed	<i>Pump settings</i>
Dry-run stop	
Dry run reset time	
Special functions	
Power-on delay	<i>Special functions</i>
Limit exceeded	
Communication	
Unit number	<i>Communication</i>
Wi-Fi	
RS485 Communication	
General	
Date and time	
Indicator lights	<i>General</i>
Backup settings	
Restore settings	

Settings
Lock
Software update
Factory reset

5) Parameters may vary depending on the control mode selected. The default control mode is **Constant pressure**.

Related information

[10. Grundfos GO dashboard](#)

[11.2 Application settings](#)

[11.3 Pump settings](#)

[11.4 Special functions](#)

[11.5 Communication](#)

[11.6 General](#)

10.4 Pump status and state

The dashboard displays the following:

- the current status of the pump
- information about the state of the system.



The displayed pump status and information may vary depending on the operation and the control mode selected.

Related information

[10. Grundfos GO dashboard](#)

[10.5 Start/stop the control mode](#)

10.5 Start/stop the control mode

You can start or stop the control mode through the dashboard by pressing the **Stop** or **Start** icons.

Related information

[10. Grundfos GO dashboard](#)

[10.4 Pump status and state](#)

10.6 Control mode metrics

The dashboard displays the current values of the control mode-related parameters.

See View all metrics section for more information.

Related information

[10. Grundfos GO dashboard](#)

[10.7 View all metrics](#)

10.7 View all metrics

On the dashboard, go to **View all metrics** to display the current values of the listed parameters.

View all metrics			
Speed (pump)	Speed of the pump in rpm.		
Power (pump)	Power in W.		
Voltage (pump)	Supply voltage in V.		
Current (pump)	Current in A.		
Electronics temperature (pump)	Temperature of the electronics.		
Operation log (pump or controller)			
	Operating hours		
	Operating hours of the pump in hours for the following intervals:		
	Total (pump)	Today (controller)	Yesterday (controller)
	Number of starts		
	Number of starts of the pump for the following intervals:		
	Total (pump)	Today (controller)	Yesterday (controller)
	Energy consumption		
	Energy consumption of the pump in kWh for the following intervals:		
	Total (pump)	Today (controller)	Yesterday (controller)
	Volume pumped		
	Volume of pumped water in m ³ for the following intervals:		
	Total (controller)	Today (controller)	Yesterday (controller)
Configurable I/O status (controller)			
	Configurable I/O 1 ⁶⁾		
	Type, Function, and Value of the configured analog input.		
	Type, Function, and Active state of the configured digital input.		
	Configurable I/O 2 ⁶⁾		
	Type, Function, and Value of the configured analog input.		
	Type, Function, and Active state of the configured digital input.		

⁶⁾ Parameters may vary depending on the CIO configuration.

Related information

[10. Grundfos GO dashboard](#)

[10.6 Control mode metrics](#)

10.8 Setpoint

The dashboard displays the current value of the setpoint.

Press **Setpoint** to change the setpoint value.

See section Constant pressure (Analog input) for more information.

Related information

[9.1 Constant pressure \(Analog input\)](#)

[10. Grundfos GO dashboard](#)

10.9 Control mode

The dashboard displays the control mode selected.

The default control mode is **Constant pressure**.

Press the icon of the control mode to modify it or its settings.

See section Control modes for more information.

Related information

[9. Control modes](#)

[10. Grundfos GO dashboard](#)

10.10 Installation log

In this menu, you can add information about the installation of your system. The information is saved in the controller and can be retrieved later if needed.

1. On the dashboard, go to **Installation log**.
2. Set the parameter you want to save in the controller:
 - **Date of installation**
 - Set the date of the installation.
 - **Pump model**
 - Select the pump type that is used in the installation.
 - **Pump depth**
 - Set how deep the pump is installed in the well.
 - **Static water level**
 - Set how high the level of the water is in the well.
 - **Well depth**
 - Set how deep the well is.
 - **Well yield**
 - Set the yield of the well.
 - **Notes**
 - Optionally, add notes regarding the installation.

Related information

[10. Grundfos GO dashboard](#)

10.11 Scheduling

Scheduling can control the pump's operation time. During the set time period, the pump remains in idle state.

1. On the dashboard, go to **Add a schedule**, then press **Add schedule**.
2. Select the schedule types:
 - **Recurring**
You can set up to 10 weekly schedules.
 - **One-time**
You can set up to 10 single schedules.
3. Select the date and time during which the pump will remain in idle state.
4. Press **Save** to save your settings.

The schedule information is displayed on the dashboard.

To add another schedule, select **View schedules** on the dashboard, then press the + icon.



If more than one schedule is set, the dashboard displays only one schedule. To see all schedules, select **View schedules**.

5. To temporarily disable scheduling, select **View schedules** on the dashboard, and then disable the function.



This action disables all previously set schedules.

6. To permanently delete a schedule, select **View schedules** on the dashboard. Then select the schedule you want to remove and press **Delete schedule**.

Related information

[10. Grundfos GO dashboard](#)

11. Setting the product

11.1 Setting by means of Grundfos GO



Make sure that all settings are entered according to the pump and system requirements to avoid malfunction.

11.2 Application settings

The parameters in the **Application settings** menu depend on the control mode selected. See the table below which parameters are available for each control mode.

Parameter	Control mode								Pump out	Pump monitoring
	Constant pressure	Level control Filling		Level control Emptying		Pressure control				
	Analog input	1 Digital input	Analog input	1 Digital input	Analog input	Digital input	Analog input			
Product name	•	•	•	•	•	•	•	•	•	
Control mode	•	•	•	•	•	•	•	•	•	
Setpoint	•									
Cut-in speed	•									
High level			•		•					
Stop level			•		•					
Start level			•		•					
Stop Pressure								•		
Start Pressure								•		
Stop functions										
• PID Controller										
- Diaphragm tank size	•									
- Manual PID controller										
• Low pressure stop										
• Max run time										
Low pressure stop								•		
Max run time						•	•			
Start delay		•	•	•	•	•	•			
Stop delay		•	•	•	•	•	•			
Signal detection time		•	•	•	•	•	•			
Unit configuration	•					•	•			
Maximum pressure safety limit	•						•			
Pumping time								•		
Pump speed								•		
Configurable Input/Output										
• Configurable I/O 1	•	•	•	•	•	•	•	• 7)	• 7)	
• Configurable I/O 2										

7) Disabled by default in **Pump out** and **Pump monitoring** control modes.

Follow the steps below to set the application:

1. Go to **Settings > Application settings**.

2. Select the parameter you want to set:

- **Product name**

- Enter the name of the product.
- Press **Save** to save your settings.

- **Control mode**

- Select the control mode and set the required parameters.

See Control modes section for more information.

- **Setpoint**

Set the pressure setpoint, see section Constant pressure (Analog input).

- **Cut-in speed**

At the start of water consumption, the pump accelerates to the cut-in speed.

The controller minimizes the pressure drop when a valve or tap is opened. During continued water consumption, the pump speed is adjusted to the desired discharge pressure.

The **Cut-in speed** function can cause excess pressure in relation to the desired discharge pressure, therefore the cut-in speed can be adjusted.

- Set **Cut-in speed**.
Value range: 3000-10,700 rpm
Default value: 8200 rpm.

- **High level, Stop level, Start level**

Set the level, see sections Level control Filling (Analog input) and Level control Emptying (Analog input).

- **Stop Pressure, Start Pressure**

Set the pressure, see section Pressure control (Analog input).

- **Stop functions**

- **PID Controller**

- **Diaphragm tank size**

Set the tank size that is used in the system.

Value range: 0-500 l.

Default value: 8 l.

- **Manual PID controller**

Set **Kp** and **Ti** values.

- **Low pressure stop**

This function prevents the pump from running at low pressure for long periods.

- Enable the function.

- Set **Low pressure stop**.

Value range for constant pressure: 0 - (**Setpoint** value minus 1 bar (15 psi)).

Default value: 0.5 bar (7 psi).

- Set **Measurement delay**.

Value range: 0-10 minutes.

Default value: 1 minute.

- Set **Delay before restart**.

Value range: 0-254 minutes.

Default value: 5 minutes.

- **Max run time**

If **Stop Pressure** is not reached within **Max run time**, the pump will stop. To start the pump, you need to reset Grundfos GO or the operating panel manually.

- Enable the function.

- Set **Max run time**.

Default value for constant pressure: 0 hours/minutes.

- **Low pressure stop**

This function prevents the pump from running at low pressure for long periods.

- Enable the function.
- Set **Low pressure stop**.
Value range for pressure control: 0 - (**Start Pressure** value minus 1 bar (15 psi)).
Default value: 0.5 bar (7 psi).
- Set **Measurement delay**.
Default value: 1 minute.
- Set **Delay before restart**.
Value range: 0-254 minutes.
Default value: 5 minutes.

- **Max run time**

If **Stop Pressure** is not reached within **Max run time**, the pump will stop. To start the pump, you need to reset Grundfos GO or the operating panel manually.

- Enable the function.
- Set **Max run time**.
Default value for pressure control: 0 hours/minutes.

- **Start delay**

The start delay is the allowed delay before the pump is started. The start delay prevents the pump from starting too frequently and reduces water hammering in long pipes.

- Enable the function.
- Set the **Start delay** time.
Value range: 0-8 hours.
Default value: 1 s.
- Press the back option to save your settings.

- **Stop delay**

The stop delay is the allowed run time of the pump after the stop level is reached. The stop delay prevents the pump from starting and stopping too frequently and reduces water hammering in long pipes.

- Enable the function.
- Set the **Stop delay** time.
Value range: 0-5 minutes.
Default value: 1 s.
- Press the back option to save your settings.

- **Signal detection time**

The signal detection time is the minimum time for which a level has to be active before the controller initiates an action, such as starting or stopping the pump.

- Set **Signal detection time**.
Value range: 0-254 s.
Default value: 0 s.
- Press **Save** to save your settings.

- **Unit configuration**

Select the pressure unit.
Value range: **bar, psi, kPa**.

- **Maximum pressure safety limit**

Set the pressure safety limit, see sections Constant pressure (Analog input), Pressure control (Analog input), and Built-in protection.

- **Pumping time, Pump speed**

Set the time and speed, see section Pump out.

- **Configurable Input/Output**

- **Configurable I/O 1**

- The configurable I/O can be configured for different functions, depending on the device connected to the terminals. The parameters can be changed through the **Control mode** menu.

- For default values, see section Control modes.

- **Configurable I/O 2**

- The configurable I/O can be configured for different functions, depending on the device connected to the terminals. The parameters can be changed through the **Control mode** menu.

- For default values, see section Control modes.

Related information

[2.12 Built-in protection](#)

[9. Control modes](#)

[9.1 Constant pressure \(Analog input\)](#)

[9.2.1 Level control Filling \(1 Digital input\)](#)

[9.2.2 Level control Filling \(Analog input\)](#)

[9.3.1 Level control Emptying \(1 Digital input\)](#)

[9.3.2 Level control Emptying \(Analog input\)](#)

[9.4 Pressure control \(Digital input\)](#)

[9.5 Pressure control \(Analog input\)](#)

[9.6 Pump out](#)

[10.3 Settings](#)

11.3 Pump settings

1. Go to **Settings > Pump settings**.

2. Select the parameter you want to set:

- **Maximum speed**

- Set the maximum pump speed.
Value range: 3000-10,700 rpm (100 rpm intervals).
- Press **Save** to save your settings.

- **Minimum speed**

- Set the minimum pump speed.
Value range: 3000 rpm - **Maximum speed** (100 rpm intervals).
- Press **Save** to save your settings.

- **Dry-run stop**

The **Dry-run stop**, power limit, is factory-set and the value depends on the power rating of the actual motor. See section Dry-running protection for more information.

If the maximum pump speed has been reduced, the **Dry-run stop** value must be changed.

- Calculate the minimum **Dry-run stop**, power limit as follows:
 - a. Start the pump against closed outlet valve.
 - b. Read the power input (P1) on the dashboard/**View all metrics** menu in Grundfos GO.
 - c. Use the following formula to calculate the minimum **Dry-run stop**, power limit:
Power limit [W] = P1 × 0,9
- Press **Save** to save your settings.

- **Dry run reset time**

- Set the dry run reset time.
Value range: 0-20 minutes.
Default value: 0 minutes.
- Press **Save** to save your settings.
- If needed, enable **Dry run double reset time**.

When the function is enabled, the set **Dry run reset time** doubles automatically for every 10 motor stops caused by an alarm. The time doubles up to a stop time of 4 hours. After 10 hours of operation without an alarm, the **Dry run reset time** is automatically set to one of the following:

- the time previously set
- 5 minutes (default value)

Related information

[2.11 Dry-running protection](#)

[10.3 Settings](#)

[13.1.10 Code 57 \(Dry running\)](#)

11.4 Special functions

1. Go to **Settings > Special functions**.

2. Select the parameter you want to set:

- **Power-on delay**

This function can delay the startup of the pump after the power supply has been switched on. It prevents disturbance in the main power network in case of multiple pumps are starting up simultaneously.

- Enable the function.
- Set the delay period. Maximum value is 1 h.

Default value: 4 s.

- **Limit exceeded**

This function can monitor an IO terminal or one of the internal values, such as current, power, speed, temperature, or voltage.

If a set limit is reached, a selected action can take place. You can set two limit exceed functions, meaning that you can monitor two parameters or two limits of the same parameter simultaneously.

- Select **Limit Exceeded 1** or **Limit Exceeded 2**.
- Enable the function for the selected limit.
- Follow the on-screen instructions and set the parameters.

Related information

[10.3 Settings](#)

[13.1.16 Code 133 \(Limit 1 exceeded\)](#)

[13.1.17 Code 133 \(Limit 2 exceeded\)](#)

11.5 Communication

1. Go to **Settings > Communication**.
2. Select the parameter you want to set:

- **Unit number**

GENIbus, the Grundfos Electronics Network Intercommunications bus, is a fieldbus developed by Grundfos to meet the need for data transfer in all typical Grundfos motor or pump applications. Grundfos devices with GENIbus can be wired together in networks and integrated in automation systems.

- Enter the GENIbus unit number.

Value range: 1-199.

Default value: 1.

The GENIbus unit number is a unique identifier for both the pump and the controller on the network.

When you change the **Unit number**, ensure that the pump is running, for example, by opening a tap to start the pump. See section Mains borne signalling for more information.

- **Wi-Fi**



Ensure that the controller is placed in an area with strong Wi-Fi signal strength and without any obstructions that could prevent a good connection. Limited Wi-Fi strength or obstructions to the controller may result in connectivity issues with the Wi-Fi and Grundfos Connect.

- Enable Wi-Fi.
- Select the network to which you want to connect.
- Enter **Password** and select **Security code**.
Default value: Automatic DHCP.
- Follow the on-screen instructions.

- **RS485 Communication**

- Select the protocol.

Default value: **GENIbus**.

- **GENIbus**

- Set the parameters:

- **Baud rate**

Value range: 9600 bit/s, 19200 bit/s, 38400 bit/s, 115200 bit/s.

Default value: 9600 bit/s.

- **Modbus RTU**

- Set the parameters:

- **Baud rate**

Value range: 9600 bit/s, 19200 bit/s, 38400 bit/s.

Default value: 9600 bit/s.

- **Stop bits**

Value range: 1, 2.

Default value: 1.

- **Parity**

Value range: **No parity, Odd parity, Even parity**.

Default value: **No parity**.

- **Modbus RTU address**

Value range: 1-247.

Default value: 1.

- **Lost connection timeout**

Value range: **Enabled, Disabled**.

Default value: 5 s when the function is enabled.

If the controller does not receive any communication signal, the pump stops at timeout.

- Press the back option to save your settings.

Related information

[2.5 Mains borne signalling](#)

[10.3 Settings](#)

11.6 General

1. Go to **Settings > General**.
2. Select the parameter you want to set:
 - **Date and time**
 - Set the date and time either manually or automatically.
 - Press **Save** to save your settings.
 - **Indicator lights**

Set the parameters:

 - **Display brightness**
Value range: **Sleep, Low, Medium, High**.
Default value: **High**.
Sleep function shuts off the LED after 2 minutes. Touch a button to wake up the operating panel.
 - **Grundfos Eye**
Value range: **Running, Constant**.
Default value: **Running**.
 - **Backup settings**
The product settings can be saved to a file to reuse them later or on other products.
By default the file name is the name of the product.
 - To change the file name, press it, enter a new name for the file, and then press **Save**.

The saved files are listed under **Restore settings**.
 - **Restore settings**
List of the saved product settings files.
 - Select the file containing the product settings you want to use for your product and load the file.
 - To share or delete a file, press the pencil icon at the top. Then press **Share** or **Delete**.



Deleting a product setting file is permanent and cannot be undone.

- **Lock**
See section Locking the controller for more information.
- **Software update**
See section Updating the software for more information.
- **Factory reset**



All product settings will be lost and the product will return to factory settings.
The product will be disconnected from Grundfos GO and the BLE pairing will not be reset.

Related information

[10.3 Settings](#)

[11.6.1 Locking the controller](#)

[11.6.2 Updating the software](#)

11.6.1 Locking the controller

The **Lock** function protects the pump and the controller by preventing changes to settings.

Follow the steps below to set the lock function:

1. Go to **Settings > General > Lock**.
2. Two levels of lock can be selected:
 - **Lock operation**
Go to step 3 for more information about this option.
 - **Lock settings (PIN code required)**
Go to step 4 for more information about this option.
3. Select **Lock operation** to lock the operating panel of the controller.
 - The buttons are inactive on the controller.
 - The lock symbol is active on the operating panel.
 - The pump can be stopped or started from Grundfos GO.

To unlock the operating panel, do one of the following options:

 - Go to Grundfos GO and disable **Lock operation**.
 - Press the **Up** and **Down** arrow buttons for 5 seconds.
4. Select **Lock settings (PIN code required)** to lock all settings in Grundfos GO and the setpoint setting on the operating panel.
 - The ON/OFF button is active on the operating panel.
 - A PIN code is required to unlock the settings.
 - The lock symbol is inactive on the operating panel.
 - The pump can be stopped or started from Grundfos GO.

To check whether the **Lock settings (PIN code required)** option is active, press the **OK** button for 3 seconds. If the lock symbol flashes 5 times, it indicates that the setpoint setting is locked and a PIN code is required to be unlocked.

To lock and unlock the settings:

- a. To lock the settings, enter a PIN code in Grundfos GO by following the on-screen instructions.
- b. To change a parameter, you can temporarily unlock the settings by entering your PIN code.
Settings are unlocked for 5 minutes.
- c. To unlock the settings permanently, press **Disable lock** and enter your PIN code again.



If you forgot your PIN code, use the last four digits of the controller's serial number to unlock the product.

Related information

[11.6 General](#)

11.6.2 Updating the software

Follow the steps below to update the product's software via Grundfos GO:

1. Make sure your smart device has sufficient power.
2. Make sure your smart device is connected to the internet.
3. Connect your product to Grundfos GO if it is not already connected.
The app automatically checks if the product has the latest software installed. If a newer version is available, the text **New software available** appears on the dashboard in Grundfos GO.
4. Follow the guide in Grundfos GO to install the software update.

Related information

[8.1 Connecting to Grundfos GO](#)

[10.1 Event notifications](#)

[11.6 General](#)

[12.1 Updating the product software](#)

12. Service

WARNING

Electric shock

Death or serious personal injury

- Switch off the power supply before you start any work on the product or connected pumps.
- Make sure that the power supply cannot be switched on unintentionally.



12.1 Updating the product software

New features and functions can be made available during the product's life cycle.

1. To update the product's software, follow the instructions in section [Updating the software](#).

Related information

[11.6.2 Updating the software](#)

12.2 Replacing the battery

CAUTION

Fire and chemical leakage

Minor or moderate personal injury

- Risk of explosion if the battery is replaced by an incorrect type.
- Dispose of the used batteries according to the given instructions.



DANGER

Intoxication or risk of chemical burn

Death or serious personal injury

- The battery can cause severe or fatal injuries in 2 hours or less if it is swallowed or placed inside any part of the body. In such an event, seek medical attention immediately.
- The replacement or servicing of batteries must be carried out by a qualified person.
- The battery contained within this product, whether new or used, is hazardous and is to be kept away from children.



The battery in this product is used for the internal real time clock and it is a standard 3 V DC BR2032 coin-cell battery.

If the battery is leaking, replace it immediately. Dispose of the used battery according to local regulations.

Replace the battery as follows:

1. Remove the front cover.
2. With a screwdriver, push the battery upwards. See also the label in the controller for reference.

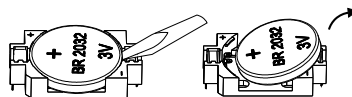

TM086084

3. Take out the battery.
4. Insert a new battery of the correct type as it is shown on the figure below.

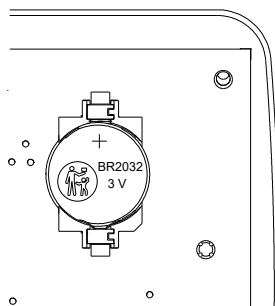

TM086083

Related information

[16.3 Environmental data](#)

13. Fault finding



WARNING

Electric shock

Death or serious personal injury

- Switch off the power supply before starting any work on the product. Make sure that the power supply cannot be switched on unintentionally.

Fault finding and fault correction must be carried out by qualified persons.

Related information

[10.1 Event notifications](#)

13.1 Alarm and warning codes

13.1.1 Code 3 (External alarm from DI)

Cause	Remedy
An external alarm is activated through the digital input.	<ul style="list-style-type: none"> • Check the device connected to the external digital input.

13.1.2 Code 10 (Communication fault, pump)

Cause	Remedy
<p>Subcode: 1001</p> <p>The pressure switch mode has reached the maximum cycles.</p>	<ul style="list-style-type: none"> • Turn off power for 1 minute and then turn it on. • Try to change the GENibus number in the controller. Make sure that the pump is running at the same time. • Check that the cables are connected correctly to the terminals. • Check that the cables are not damaged. • Check that the pump is working without the controller.

13.1.3 Code 12 (Service needed)

Cause	Remedy
Maintenance is required.	<ul style="list-style-type: none"> • Service the pump and restart the counter.

13.1.4 Code 25 (Setup conflict)

Cause	Remedy
<p>Subcode: 1001 The IO terminal is not configured correctly.</p>	<ul style="list-style-type: none"> • Check and adjust the configuration of the selected IO terminal with Grundfos GO.
<p>Subcode: 1005 Analog sensor: The levels are not configured correctly, for example, in case of Filling, the start level is higher than the stop level. Digital sensor: The stop or start switches are not configured correctly.</p>	<ul style="list-style-type: none"> • Check and adjust the level control configuration with Grundfos GO.
<p>Subcode: 1009 Analog sensor only: The start or the stop level settings are invalid or missing.</p>	<ul style="list-style-type: none"> • Check and adjust the start or the stop level settings, or change the sensor setup with Grundfos GO.
<p>Subcode: 1010 Analog sensor only: The analog level sensor is not valid or not configured.</p>	<ul style="list-style-type: none"> • Check and configure the analog level sensor with Grundfos GO.
<p>Subcode: 1011 Analog/Digital sensor: level switch setting is duplicated.</p>	<ul style="list-style-type: none"> • Check and adjust the level switch setting with Grundfos GO.
<p>Subcode: 1014 The control mode is not compatible with the controller type.</p>	<ul style="list-style-type: none"> • Reset the controller to default factory settings with Grundfos GO.
<p>Subcode: 1021 In Level control control mode, the input type is set as analog input. Setting a digital input raises an alarm.</p>	<ul style="list-style-type: none"> • In Grundfos GO, go to the Settings menu and remove the digital input(s).

13.1.5 Code 32 (Overvoltage)

Cause	Remedy
Subcode: 1001 Inrush: The supply voltage has exceeded the maximum allowed value.	<ul style="list-style-type: none"> • Measure voltage and ensure it is within the specifications of the pump. Check the motor nameplate.
Subcode: 1002 DPFC: The supply voltage has exceeded the maximum allowed value.	<ul style="list-style-type: none"> • Measure voltage and ensure it is within the specifications of the pump. Check the motor nameplate.
Subcode: 1003 ICL: The supply voltage has exceeded the maximum allowed value.	<ul style="list-style-type: none"> • Measure voltage and ensure it is within the specifications of the pump. Check the motor nameplate.

13.1.6 Code 40 (Undervoltage)

Cause	Remedy
The supply voltage is lower than the specified limit.	<ul style="list-style-type: none"> • Measure the supply voltage and ensure it is within the rated voltage range. Check the nameplate of the controller. • Check if the cable dimensions are correct.

Related information[3.3.1 Nameplate](#)**13.1.7 Code 46 (External warning from DI)**

Cause	Remedy
An external warning is activated via the digital input.	<ul style="list-style-type: none"> • Check the device connected to the external digital input.

13.1.8 Code 48 (Motor is overloaded)

Cause	Remedy
The pump is clogged. The blockage causes the motor current to rise, which could damage the pump.	<ul style="list-style-type: none"> • Turn off power for 1 minute and then turn it on. • Remove the blockage. • Check the pit for additional blockages. • Replace the pump if needed.

13.1.9 Code 51 (Blocked motor/pump)

Cause	Remedy
<p>Subcode: 1001 The pump is blocked. The pump cannot rotate due to a blockage. Lost rotor.</p>	<ul style="list-style-type: none"> • Dismantle the pump by removing the pump head, and remove any blockage or impurities preventing the pump from rotating. • Check the water quality to eliminate the risk of lime precipitation. Before dismantling the pump, drain the system or close the isolating valves on either side of the pump. The pumped liquid may be scalding hot and under high pressure. • Replace the pump if needed.
<p>Subcode: 1002 The pump is blocked. The motor is blocked. The pump cannot rotate due to a blockage.</p>	<ul style="list-style-type: none"> • Dismantle the pump by removing the pump head, and remove any blockage or impurities preventing the pump from rotating. • Check the water quality to eliminate the risk of lime precipitation. Before dismantling the pump, drain the system or close the isolating valves on either side of the pump. The pumped liquid may be scalding hot and under high pressure. • Replace the pump if needed.
<p>Subcode: 1003 The pump is blocked. The pump cannot rotate due to a blockage. Derating.</p>	<ul style="list-style-type: none"> • Dismantle the pump by removing the pump head, and remove any blockage or impurities preventing the pump from rotating. • Check the water quality to eliminate the risk of lime precipitation. Before dismantling the pump, drain the system or close the isolating valves on either side of the pump. The pumped liquid may be scalding hot and under high pressure. • Replace the pump if needed.

13.1.10 Code 57 (Dry running)

Cause	Remedy
<p>Subcode: 1002</p> <p>Power limit: The dry-run power limit function detects low water level in the pit and the pump stops due to the dry running function.</p>	<ul style="list-style-type: none"> • Adjust the maximum speed of the pump. • Replace the pump with a correctly dimensioned variant. • Check that the dry run power limit is set correctly and matches the installation.
<p>Subcode: 1003</p> <p>Analog: The input CIO port detects low water level in the pit and the pump stops due to the dry running function.</p>	<ul style="list-style-type: none"> • Check the water level at the sensor.
<p>Subcode: 1004</p> <p>Analog: The input CIO port detects low water level in the pit and the pump stops due to the dry running function.</p>	<ul style="list-style-type: none"> • Check the pressure at the sensor.
<p>Subcode: 1005</p> <p>Digital: The input CIO port detects low water level in the pit and the pump stops due to the dry running function.</p>	<ul style="list-style-type: none"> • Check the water level at the switch.

Related information

[2.11 Dry-running protection](#)

[11.3 Pump settings](#)

13.1.11 Code 59 (No flow)

Cause	Remedy
Flow is not detected.	<ul style="list-style-type: none"> • Check the pump, valves or pipes for blockage.

13.1.12 Code 67 (Temperature too high, internal frequency converter module (t_m))

Cause	Remedy
Valves are closed while the pump is running.	<ul style="list-style-type: none"> • Open the valve(s).
High water temperature.	<ul style="list-style-type: none"> • Check the pump, valves or pipes for blockage.
Insufficient cooling.	<ul style="list-style-type: none"> • Ensure that there is flow around the motor.

13.1.13 Code 73 (Hardware shutdown (HSD))

Cause	Remedy
<p>Subcode: 1001 Insulation displacement contact (IDC): Hardware shuts down because of detecting incorrect software or offset error.</p>	<ul style="list-style-type: none"> • Turn off power for 1 minute and then turn it on. • If the error persists, contact Grundfos.
<p>Subcode: 1002 Analog digital converter (ADC): Hardware shuts down because of detecting incorrect software or gain multiplexer error.</p>	<ul style="list-style-type: none"> • Turn off power for 1 minute and then turn it on. • If the error persists, contact Grundfos.
<p>Subcode: 1003 Inrush current limiter (ICL): Hardware shuts down because of detecting incorrect software or HSD in the feedback loop.</p>	<ul style="list-style-type: none"> • Turn off power for 1 minute and then turn it on. • If the error persists, contact Grundfos.
<p>Subcode: 1004 Motor current measurement fault: Current measurement hardware of the pump is broken or not working.</p>	<ul style="list-style-type: none"> • If the error persists, contact Grundfos. • Replace the pump if needed.
<p>Subcode: 1005 Turbine: Hardware shuts down because of detecting incorrect software or backflow in the pump.</p>	<ul style="list-style-type: none"> • Check the non-return valve for leakage. • Remove the blockage. • Turn off power for 1 minute and then turn it on. • If the error persists, contact Grundfos.

13.1.14 Code 89 (Signal fault, (feedback) sensor 1)

Cause	Remedy
The primary feedback sensor indicates a fault in Constant pressure control mode.	<ul style="list-style-type: none"> • Check the sensor. • Replace the sensor if needed.

Related information

[9.1 Constant pressure \(Analog input\)](#)

13.1.15 Code 117 (Door opened)

Cause	Remedy
The door to the control unit room has been opened.	<ul style="list-style-type: none"> • Check the room with the control unit.

13.1.16 Code 133 (Limit 1 exceeded)

Cause	Remedy
Subcode: 1001 The configured parameter for limit 1 has exceeded its limit set by the user.	<ul style="list-style-type: none"> • Check the input. • Change the configuration by adjusting the limits set in Grundfos GO.

Related information

[11.4 Special functions](#)

13.1.17 Code 133 (Limit 2 exceeded)

Cause	Remedy
Subcode: 1002 The configured parameter for limit 2 has exceeded its limit set by the user.	<ul style="list-style-type: none"> • Check the input. • Change the configuration by adjusting the limits set in Grundfos GO.

Related information

[11.4 Special functions](#)

13.1.18 Code 157 (Real Time Clock battery fault)

Cause	Remedy
The battery for real time clock is missing or worn out so the product is unable to maintain time and date.	<ul style="list-style-type: none"> • Replace the battery with a new one.

13.1.19 Code 165 (Signal fault)

Cause	Remedy
The analog sensor is defective.	<ul style="list-style-type: none"> • Check the wiring and sensor status. • Replace the sensor if needed.

13.1.20 Code 191 (High water level)

Cause	Remedy
Digital sensor: High water level is detected.	<ul style="list-style-type: none"> • Check and configure the sensor high level.

13.1.21 Code 197 (Constant pressure: Low pressure)

Cause	Remedy
In Constant pressure control mode, the pump is not able to reach the setpoint within a time limit and then it runs with warning code 197.	<ul style="list-style-type: none"> • Check if any leakage is present.

Related information

[9.1 Constant pressure \(Analog input\)](#)

13.1.22 Code 200 (Pump Out interrupted (Pump))

Cause	Remedy
<p>Subcode:1001</p> <p>The Pump Out control mode has been interrupted by either a pump alarm, the ON/OFF button, or power interruption.</p>	<ul style="list-style-type: none"> • Check if any pump alarms caused the interruption in the control mode, and remedy those alarms.

Related information

[9.6 Pump out](#)

13.1.23 Code 200 (Pressure control: Max run time (Max))

Cause	Remedy
<p>Subcode: 1002</p> <p>In Pressure control control mode, the stop pressure level cannot be reached within the maximum allowed runtime.</p> <p>Pressure build up failed within the set time.</p>	<ul style="list-style-type: none"> • Check the leakage in the pipeline and stop the leakage if any. • Push the ON/OFF button to reset the alarm. • If the error persists, contact Grundfos.

Related information

[9.4 Pressure control \(Digital input\)](#)

[9.5 Pressure control \(Analog input\)](#)

13.1.24 Code 200 (Constant pressure: Max run time)

Cause	Remedy
<p>Subcode: 1008</p> <p>In Constant pressure control mode, the maximum run time is reached without reaching the setpoint.</p>	<ul style="list-style-type: none"> • Check the leakage in the pipeline and stop the leakage if any. • Push the ON/OFF button to reset the alarm. • If the error persists, contact Grundfos.

Related information

[9.1 Constant pressure \(Analog input\)](#)

13.1.25 Code 205 (Level float switch sequence inconsistency)

Cause	Remedy
<p>Sensor sequence is incorrect. A sensor could be defective or stuck.</p>	<ul style="list-style-type: none"> • Check the functionality of each sensor. • Correct the sequence of the sensors.

13.1.26 Code 210 (Overpressure)

Cause	Remedy
The registered pressure is 1.5 bar (21.75 psi) above the setpoint. The pump has been stopped to avoid causing damage to the system.	<ul style="list-style-type: none"> • Reduce the cut-in speed to avoid overshoot at startup. • Check if any other equipment increases the pressure such as a water heater, and so on.

Related information

[2.12 Built-in protection](#)

[9.1 Constant pressure \(Analog input\)](#)

13.1.27 Code 211 (Underpressure)

Cause	Remedy
The pump cannot reach the low pressure setpoint and has stopped.	<ul style="list-style-type: none"> • Check the discharge hose for blockage. • Check the flow direction of the valves (arrow) and correct them if necessary. • Reduce the backpressure. Enlarge the diameter of the outlet line.

Related information

[2.12 Built-in protection](#)

[9.1 Constant pressure \(Analog input\)](#)

13.1.28 Code 226 (Communication fault, I/O module)

Cause	Remedy
Communication is lost to the IO module.	<ul style="list-style-type: none"> • Check cable connection to the IO module. • Check if the IO module is powered correctly.

13.1.29 Code 229 (Water on floor)

Cause	Remedy
Digital: The sensor detects water on the floor.	<ul style="list-style-type: none"> • Check for water leakage.

14. Remote monitoring

To monitor your system remotely, connect to the Grundfos Connect platform via Wi-Fi or via the CIM/CIU interfaces.

See the Grundfos Connect website for more information:

<https://product-selection.grundfos.com/products/grundfos-utility-connect?tab=explore>



Ensure that the controller is placed in an area with strong Wi-Fi signal strength and without any obstructions that could prevent a good connection. Limited Wi-Fi strength or obstructions to the controller may result in connectivity issues with the Wi-Fi and Grundfos Connect.

15. Decommissioning



CAUTION

Cyber security hazard

Minor or moderate personal injury

- Delete all information before decommissioning.

16. Technical data

16.1 Electrical data

Supply voltage

90-240 VAC -10 % / +6 %, PE

The wires must be rated at minimum 60 °C (140 °F), minimum 20 AWG.



Use copper, copper-clad aluminum, or aluminum conductors in the terminals.

Frequency

50/60 Hz

Rated current

Maximum 12.5 A

Ratings

Overvoltage, category III

Mains fuses

Maximum 16 A

Maximum control unit power dissipation

Powered by AC: 25 W

Powered by DC: 25 W

CIO1 and CIO2 terminals, combined input/output

Power supplies, +24 V

Output voltage: 24 VDC -10 % / +10 %

Maximum supply 300 mA in total

Digital input

10 kΩ pull-up against 24 VDC

Low logic level below 9.75 V

High logic level higher than 12.0 V

Pulse input

10 kΩ pull-up against 24 VDC

Highest frequency 10 Hz, 50 % duty-cycle

Digital output

Open collector

Current sink capability: maximum 75 mA, no sourcing

Overcurrent protected

Analog output

0-10 V, max. 20 mA

0-20 mA, load ≤ 500 Ω

4-20 mA, load ≤ 500 Ω

Analog input

0-10 V, load 100 kΩ

A warning or an alarm is raised when the voltage is under range 0 V or over range 11 V.

0-5 V, load 100 kΩ

A warning or an alarm is raised when the voltage is under range 0 V or over range 5.5 V.

0.5 - 3.5 V, load 100 kΩ

A warning or an alarm is raised when the voltage is under range 0.2 V or over range 3.8 V.

0-20 mA, voltage drop max. 2 V

A warning or an alarm is raised when the current is under range 0 mA or over range 22 mA.

4-20 mA, voltage drop max. 2 V

A warning or an alarm is raised when the current is under range 2 mA or over range 22 mA.

Related information

- 4. [Installation requirements](#)
- 6.1 [Cable requirements](#)
- 6.3 [Connecting the pump supply and power supply](#)
- 6.6 [Terminal blocks](#)

16.2 Temperature**Ambient temperature**

Min. ambient temperature	-20 °C (-4 °F)
Max. ambient temperature	+50 °C (+122 °F)

Storage temperature

Min. storage temperature	-30 °C (-22 °F)
Max. storage temperature	+60 °C (+140 °F)

16.3 Environmental data**Enclosure class**

CU 302: IP55.
CU 302 UL: Type 1 / Type 3R raintight.

Materials

The box is made of black PPO.

Relative humidity

5-95 %.

Pollution degree

Category 2.

Battery

Size BR2032.

Related information

- 12.2 [Replacing the battery](#)

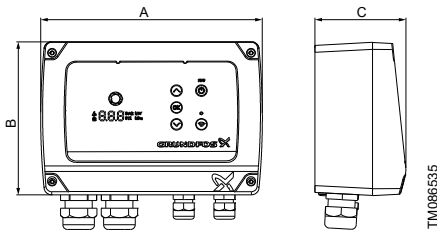
16.4 Dimensions

Dimensions of the controller

Pos.	Description
A	232 mm (9.1 inch)
B	160 mm (6.3 inch)
C	96 mm (3.8 inch)

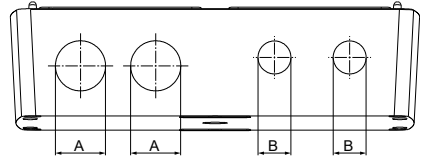

Diameter of the cable gland holes, CU 302

Pos.	Description
A	∅ 28.3 mm (1.11 inch)
B	∅ 18.6 mm (0.73 inch)

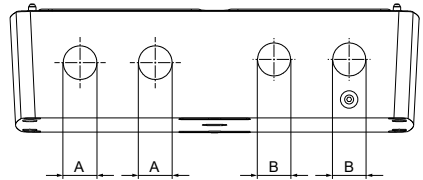

Diameter of the cable gland holes, CU 302 UL

Pos.	Description
A	∅ 22.23 mm (0.875 inch)
B	∅ 18.6 mm (0.73 inch)

Related information

- 5.4 [Mounting the rubber seals](#)
- 6.1 [Cable requirements](#)

16.5 Weights

1.24 kg (2.73 lb)

16.6 Miscellaneous data**Motor protection**

Software class A.

Type 1 action according to IEC 60730-1.

The controller always restarts after an alarm has been reset.

17. Disposing of the product

This product or parts of it must be disposed of in an environmentally sound way.

1. Use the public or private waste collection service.
2. If this is not possible, contact the nearest Grundfos company or service workshop.
3. Dispose of the waste battery through the national collective schemes. If in doubt, contact your local Grundfos company.



The crossed-out wheellie bin symbol on a product means that it must be disposed of separately from household waste. When a product marked with this symbol reaches its end of life, take it to a collection point designated by the local waste disposal authorities.

The separate collection and recycling of such products will help protect the environment and human health.

See also end-of-life information at www.grundfos.com/product-recycling.

18. Product feedback

Scan the QR code or click the link below to provide feedback about the product.



FEEDBACKCU30/2GB

[Click here to submit your feedback](#)

19. Document quality feedback

To provide feedback about this document, use your smart device to scan the QR code.



FEEDBACK92852550

[Click here to submit your feedback](#)

Limited consumer warranty

1. Limited consumer warranty

This Limited Warranty is provided for Consumer Products sold in the United States only and applies to Consumer Transactions as defined in and applicable under the Magnusson-Moss Warranty Act and any other applicable Federal and/or State laws. In case of non-Consumer Products, please refer to Grundfos' warranty terms defined in clause 10 of Grundfos US Terms and Conditions of Sale of Product and Services available at <https://www.grundfos.com/legal/grundfos-customer-terms/usa-grundfos-general-terms-for-sales-of-products-and-services>

This Limited Warranty gives you specific legal rights, and you may also have other rights which vary from State to State.

New products manufactured by Grundfos are warranted to the original purchaser only and are to be free from defects in design, material and workmanship under normal use and service for no greater than a period of thirty (30) months from the date of manufacture which is set forth on the product's nameplate and on the product's packaging or the minimum period required by the applicable State law. For New Jersey, the applicable period is one year from the date of purchase.

The warranty period for replacement products, parts and components expires thirty (30) months from the original date of manufacture of the product originally purchased, unless a longer period is required under the applicable State law. For New Jersey, the warranty period for replacement products, parts and components expires one year from the original date of purchase of the product, not the date of replacement.

Products sold by Grundfos that are manufactured by others are not covered by this warranty.

Note that when purchasing a Grundfos product online, it is important to check the date of manufacture and the duration of the warranty with the seller as the product might no longer be covered under this Limited Warranty.

When a product is subject to this Limited Warranty a purchaser should contact the seller from which it purchased the product to make a claim.

If the seller of a product is no longer in business, the purchaser should contact a Grundfos Authorized Service Partner, which can be found at www.grundfos.com/us under > Support > Contact Service.

As part of making a claim, a purchaser shall return a defective product at the purchaser's cost, to the extent allowed by applicable law, along with proof of purchase and an explanation of the defect, date the defect occurred and circumstances surrounding the defect. For New Jersey there is no prohibition on returning a defective product at a purchaser's cost. If Grundfos is required by applicable State law to pay for the cost of shipment under applicable State law, then a purchaser should contact a Grundfos Authorized Service Partner to arrange for shipment. A purchaser also needs to promptly respond to Grundfos as to any inquiries regarding a warranty claim.

Grundfos' liability under this Limited Warranty to purchaser is limited to the repair or replacement of a product (at Grundfos' decision) that is the sole and exclusive remedy for purchaser to the extent permissible by applicable law. For New Jersey this limitation is permissible.

This warranty does not cover the following: ordinary wear and tear; use of a product for applications for which it is not intended; use of a product in an unsuitable environment; modifications, alterations or repair undertaken by anyone not acting with Grundfos' written authorization; failure to follow Grundfos' instructions, operations manuals, any other guidelines or good industry practice; use of faulty or inadequate ancillary equipment in combination with a product; application of spare or replacement parts not provided or authorized by Grundfos; accidental or intentional damage or misuse of a product.

The time period for making a claim under the implied warranty of merchantability and implied warranty of fitness are limited to the same time period as provided by this warranty to the extent permissible by applicable law. For residents of New Jersey, this limitation is permissible, but note that some states do not allow limitations on how long an implied warranty lasts, so the above limitation may not apply to you.

Grundfos shall not be liable for any incidental and consequential damages in connection with a product to the extent permissible by applicable law. For residents of New Jersey, this limitation is permissible, but note that some states do not allow limitations of incidental or consequential damages, so the above limitation may not apply to you.

2. Garantía limitada del consumidor

Esta garantía limitada se proporciona únicamente para los productos de consumo vendidos en los Estados Unidos y es aplicable a las transacciones de consumo tal y como se define en y resulta aplicable en virtud de la ley de Garantías Magnusson-Moss y cualquier otra legislación federal y/o estatal aplicable. Para el caso de productos que no sean de consumo, consulte los términos de la garantía de Grundfos definidos en la cláusula 10 de los términos y condiciones de venta de productos y servicios de Grundfos para los EE. UU., disponibles en <https://www.grundfos.com/legal/grundfos-customer-terms/usa-grundfos-general-terms-for-sales-of-products-and-services>.

Esta garantía limitada le confiere derechos legales específicos. Puede que también tenga otros derechos en virtud de su jurisdicción estatal.

Se garantiza únicamente al comprador original que los productos fabricados por Grundfos estarán libres de defectos de diseño, materiales y mano de obra en condiciones normales de uso y servicio durante un periodo no mayor a treinta (30) meses a partir de la fecha de fabricación que figura en la placa de datos del producto y en el empaque del mismo o el periodo mínimo exigido por la legislación estatal aplicable. Para Nueva Jersey, el periodo aplicable es de un año a partir de la fecha de compra.

El periodo de garantía para los productos, partes y componentes de repuesto vence a los treinta (30) meses contados a partir de la fecha de fabricación original del producto adquirido en primer lugar, a menos que la legislación estatal aplicable exija un periodo más largo. Para Nueva Jersey, el periodo de garantía de los productos, partes y componentes de repuesto vence un año contado a partir de la fecha original de compra del producto, no de la fecha de sustitución.

Los productos vendidos por Grundfos que sean producidos por otros fabricantes no están cubiertos por esta garantía.

Tenga en cuenta que, al comprar un producto Grundfos en línea, es importante revisar la fecha de fabricación y la duración de la garantía con el vendedor, ya que es posible que el producto ya no esté cubierto por esta garantía limitada.

Cuando un producto esté sujeto a esta garantía limitada, el comprador deberá ponerse en contacto con el vendedor al que haya comprado el producto para presentar una reclamación.

Si el vendedor de un producto ya no está en el negocio, el comprador debe ponerse en contacto con socio de servicio autorizado por Grundfos, que puede encontrar en la dirección www.grundfos.com/us, en la sección "Support" > "Contact Service".

Como parte de la presentación de una reclamación, el comprador deberá devolver el producto descompuesto a su costa, en la medida en la que lo permita la legislación aplicable, junto con el comprobante de compra y una explicación del defecto, la fecha en que este se haya producido y las circunstancias en torno al defecto. En Nueva Jersey no existe ninguna prohibición de devolver un producto descompuesto a costa del comprador. Si la legislación estatal aplicable obliga a Grundfos a hacerse cargo de los gastos de envío, el comprador deberá ponerse en contacto con un servicio técnico autorizado por Grundfos para organizar el envío. El comprador también debe responder con prontitud a Grundfos cualquier consulta relacionada con una reclamación de garantía.

La responsabilidad de Grundfos hacia el comprador en virtud de esta garantía limitada se limita a la reparación o sustitución de un producto (a decisión de Grundfos), que es el único y exclusivo remedio para el comprador en la medida permitida por la legislación aplicable. Para Nueva Jersey, esta limitación resulta permisible.

Esta garantía no cubre lo siguiente: el desgaste ordinario; el uso de un producto para aplicaciones para las que no está diseñado; el uso de un producto en un entorno inadecuado; las modificaciones, alteraciones o reparaciones realizadas por cualquier persona que no actúe con la autorización por escrito de Grundfos; el incumplimiento de las instrucciones, manuales de operación, cualquier otro lineamiento o las buenas prácticas industriales de Grundfos; el uso de equipos auxiliares descompuestos o inadecuados en combinación con un producto; el uso de repuestos o partes de sustitución no proporcionados ni autorizados por Grundfos; el daño accidental o deliberado o el uso indebido de un producto.

El periodo para presentar una reclamación en virtud de la garantía implícita de comerciabilidad y la garantía implícita de idoneidad se limita al mismo periodo previsto por esta garantía en la medida permitida por la legislación aplicable. Para los residentes de Nueva Jersey, esta limitación resulta permisible, si bien se debe tener en cuenta que algunos estados no permiten limitaciones en cuanto a la duración de una garantía implícita, por lo que la limitación anterior puede no resultar aplicable en su caso.

Grundfos no será responsable de ningún daño indirecto o consecuente en relación con un producto en la medida en la que lo permita la legislación aplicable. Para los residentes de Nueva Jersey, esta limitación resulta permisible, si bien debe tenerse en cuenta que algunos estados no permiten limitaciones en cuanto a daños indirectos o consecuentes, por lo que la limitación anterior puede no resultar aplicable en su caso.

Limited manufacturer's warranty

1. Limited manufacturer's warranty

This Limited Manufacturer's Warranty outlines applicable coverage and claims procedures for the pumps manufactured by Grundfos (the "Product").

This Limited Manufacturer's Warranty is provided for consumer products sold and used in Canada only and applies to consumer transactions as defined in the applicable provincial and territorial laws. In case of non-consumer products, please refer to Grundfos' warranty terms defined in clause 10 of Grundfos Canada Terms and Conditions of Sale of Product and Services available at: <https://www.grundfos.com/ca/legal/general-terms-and-conditions-of-sales-and-delivery>

This Limited Manufacturer's Warranty provides specific rights and limitations. Some of the limitations may not apply to you, and you may also have other rights that vary from province to province.

Scope of the Limited Manufacturer's Warranty

Subject to the following warranty terms and conditions, Grundfos Canada Inc. of 2941 Brighton Rd, Oakville, ON L6H 6C9, Canada ("Grundfos"), warrants to the original consumer (the "Purchaser") that the new Product manufactured by Grundfos is free from defects in design, material and workmanship under normal use and service for a period of twenty-four (24) months from the date of retail purchase but no greater than a period of thirty (30) months from the date of manufacture which is set forth on the Product's nameplate and on the Product's packaging (the "Warranty Period").

Note that when purchasing a Grundfos Product online, it is important to check the date of manufacture and the duration of the warranty with the seller as the Product might no longer be covered under this Limited Manufacturer's Warranty.

This Limited Manufacturer's Warranty applies exclusively to a new Grundfos Product sold and used in Canada. This Limited Manufacturer's Warranty does not apply to any Product sold "as is" or "sales final". This Limited Manufacturer's Warranty is not transferrable by the original Purchaser. Products sold by Grundfos that are manufactured by others are not covered by this warranty.

The sole and exclusive remedy under this Limited Manufacturer's Warranty is the repair or, at the discretion of Grundfos, the replacement of the Product, as set out below. Defects or damages are not covered by the Limited Manufacturer's Warranty if they are due to:

- ordinary wear and tear;
- use of the Product for an application for which it is not intended;
- installation of the Product in an environment not suitable for the Product;
- any modification, alteration or repair of the Product undertaken by the Purchaser or a third party (not acting on Grundfos' behalf);
- failure to follow Grundfos' instructions, including in the installation manual, operation manual, maintenance manual or service manual;
- installation, commissioning, operation (including the use of the Product or any Grundfos product outside its specifications) or maintenance of the Product other than in accordance with Grundfos installation manual, operation manual, maintenance manual or service manual or with good industry practice;
- use of faulty or inadequate ancillary equipment in combination with the Product;
- the application of spare parts of poor quality (excluding the application of any Grundfos original spare parts);
- accidental or intentional damage or misuse of the Products or services by the Purchaser or a third party (not acting on Grundfos' behalf); or
- the non-compliance of the Purchaser or of the Purchaser's own products with applicable law and regulation.

How to get service under the Limited Manufacturer's Warranty:

When a Product is subject to this Limited Manufacturer's Warranty, the Purchaser should contact the seller from which it purchased the Product to make a claim within 24 months from the date of retail purchase but no later than thirty (30) months from the date of manufacture which is set forth on the Product's nameplate and on the Product's packaging (the "Warranty Notification Period").

If the seller of a Product is no longer in business, the Purchaser should contact Grundfos Service at www.grundfos.com/us under **Support > Contact Service**.

To exercise the rights under this Limited Manufacturer's Warranty, the Purchaser shall return a defective Product at the Purchaser's cost, to the extent allowed by applicable law, along with proof of purchase and an explanation of the defect, date the defect occurred and circumstances surrounding the defect.

The Purchaser is responsible for any expenses for dismounting and mounting the Product and for any and costs related to removal, reinstallation, transportation, and insurance. If Grundfos is required by applicable provincial or territorial law to pay for the cost of transportation, then the Purchaser should contact Grundfos Service Partner to arrange for shipment. The Purchaser also needs to promptly respond to Grundfos as to any inquiries regarding a warranty claim.

Unless requested by Grundfos, the Product may not be disassembled prior to remedy. Any failure to comply herewith will render this Limited Manufacturer's Warranty void.

Grundfos will either arrange the repair of the defective Product under this Limited Manufacturer's Warranty or, at Grundfos' option, provide the Purchaser with a replacement of the defective Product. The replacement unit can be new or remanufactured.

To the extent permissible by applicable law, Grundfos shall not be liable for any incidental and consequential damages or losses of any kind whatsoever arising under, relating to or in connection with the Product, use of the Product or the inability to use the Product.

2. Garantie limitée du fabricant

Cette garantie limitée du fabricant décrit la couverture applicable et les procédures de réclamation pour les pompes fabriquées par Grundfos (ci-après le « Produit »).

Cette garantie limitée du fabricant est fournie pour les produits de consommation vendus et utilisés au Canada uniquement et s'applique aux transactions de consommateurs telles que définies dans les lois provinciales et territoriales applicables. Dans le cas de produits non destinés aux consommateurs, se référer aux conditions de garantie de Grundfos définies à l'article 10 des Conditions générales de vente des produits et services de Grundfos Canada, qui sont disponibles à l'adresse suivante : <https://www.grundfos.com/ca/fr/legal/general-terms-and-conditions-of-sales-and-delivery>

Cette garantie limitée du fabricant prévoit des droits et des limitations spécifiques. Certaines des limitations peuvent ne pas s'appliquer à vous, et vous pouvez également bénéficier d'autres droits qui varient d'une province à l'autre.

Champ d'application de la garantie limitée du fabricant

Sous réserve des conditions générales de garantie suivantes, Grundfos Canada Inc., dont le siège social est situé au 2941, Brighton Rd, Oakville, ON L6H 6C9, Canada (ci-après « Grundfos »), garantit au consommateur initial (ci-après « l'Acheteur ») que le nouveau Produit fabriqué par Grundfos est exempt de défauts de conception, de matériaux et de fabrication dans des conditions normales d'utilisation et d'entretien pendant une période de vingt-quatre (24) mois à compter de la date d'achat au détail, mais pas plus de trente (30) mois à compter de la date de fabrication indiquée sur la plaque signalétique et sur l'emballage du Produit (« Période de garantie »).

Lors de l'achat d'un Produit Grundfos en ligne, il est important de vérifier la date de fabrication et la durée de la garantie auprès du vendeur, car le Produit pourrait ne plus être couvert par cette garantie limitée du fabricant.

Cette garantie limitée du fabricant s'applique exclusivement à un Produit Grundfos neuf vendu et utilisé au Canada. Cette garantie limitée du fabricant ne s'applique pas aux Produits vendus « en l'état » ou « vente finale ». La présente garantie limitée du fabricant n'est pas transférable par l'Acheteur initial. Les produits vendus par Grundfos qui sont fabriqués par des tiers ne sont pas couverts par cette garantie.

Le seul et unique recours dans le cadre de cette garantie limitée du fabricant est la réparation ou, à la discrétion de Grundfos, le remplacement du Produit, comme indiqué ci-dessous. Les défauts ou dommages ne sont pas couverts par la garantie limitée du fabricant s'ils sont dus à :

- l'usure normale ;
- l'utilisation du Produit pour une application pour laquelle il n'est pas prévu ;
- l'installation du Produit dans un environnement non adapté au Produit ;
- toute modification, altération ou réparation du Produit entreprise par l'Acheteur ou un tiers (n'agissant pas pour le compte de Grundfos) ;
- la non-observation des instructions de Grundfos, y compris dans les notices d'installation, d'utilisation, de maintenance ou d'entretien ;
- l'installation, la mise en service, l'utilisation (y compris l'utilisation du Produit ou de tout produit Grundfos en dehors de ses spécifications) ou l'entretien du Produit autrement que conformément aux notices d'installation, d'utilisation, de maintenance ou d'entretien Grundfos ou aux bonnes pratiques de l'industrie ;
- l'utilisation d'un équipement auxiliaire défectueux ou inadéquat en combinaison avec le Produit ;
- l'utilisation de pièces de rechange de mauvaise qualité (à l'exclusion de l'utilisation de pièces de rechange d'origine Grundfos) ;
- tout dommage accidentel ou intentionnel ou toute mauvaise utilisation des Produits ou des services par l'Acheteur ou un tiers (n'agissant pas pour le compte de Grundfos) ; ou
- la non-conformité de l'Acheteur ou de ses propres produits aux lois et règlements applicables.

Procédure à suivre pour bénéficier d'un service dans le cadre de la garantie limitée du fabricant :

Lorsqu'un Produit est soumis à la présente garantie limitée du fabricant, l'Acheteur doit contacter le vendeur auprès duquel il a acheté le produit pour faire une réclamation dans les 24 mois suivant la date d'achat au détail, mais au plus tard trente (30) mois à compter de la date de fabrication indiquée sur la plaque signalétique du Produit et sur l'emballage du Produit (« Période de notification de garantie »).

Si le vendeur d'un Produit n'est plus en activité, l'Acheteur doit contacter le service Grundfos à l'adresse www.grundfos.com/us sous **Support > Contact Service**.

Pour exercer les droits prévus par la présente garantie limitée du fabricant, l'Acheteur doit renvoyer le Produit défectueux à ses frais, dans la mesure où la loi applicable le permet, accompagné de la preuve d'achat et d'une explication du défaut, de la date à laquelle le défaut s'est produit et des circonstances entourant le défaut.

L'Acheteur est responsable de tous les frais de démontage et de montage du Produit et de tous les frais liés à l'enlèvement, à la réinstallation, au transport et à l'assurance. Si Grundfos est tenu par la loi provinciale ou territoriale applicable de payer les frais de transport, l'Acheteur doit contacter le partenaire de service Grundfos pour organiser l'expédition. L'Acheteur doit également répondre rapidement à Grundfos pour toute demande concernant une réclamation au titre de la garantie.

Sauf demande de Grundfos, le Produit ne doit pas être démonté avant d'être remis en état. Tout manquement à ces dispositions entraînera l'annulation de la présente garantie limitée du fabricant.

Grundfos procédera à la réparation du Produit défectueux dans le cadre de cette garantie limitée du fabricant ou, à la convenance de Grundfos, fournira à l'Acheteur un produit de remplacement du Produit défectueux. L'unité de remplacement peut être neuve ou refabriquée.

Dans la mesure autorisée par la loi applicable, Grundfos ne sera pas responsable des dommages accessoires et indirects ou des pertes de quelque nature que ce soit découlant de, liés à ou en rapport avec le Produit, l'utilisation du Produit ou l'incapacité d'utiliser le Produit.

Argentina

Bombas GRUNDFOS de Argentina S.A.
Ruta Panamericana km. 37.500 Industrias
1619 - Garin Pcia. de B.A.
Tel.: +54-3327 414 444
Fax: +54-3327 45 3190

Australia

GRUNDFOS Pumps Pty. Ltd.
P.O. Box 2040
Regency Park
South Australia 5942
Tel.: +61-8-8461-4611
Fax: +61-8-8340-0155

Austria

GRUNDFOS Pumpen Vertrieb
Ges.m.b.H.
Grundfosstraße 2
A-5082 Grödig/Salzburg
Tel.: +43-6246-883-0
Fax: +43-6246-883-30

Belgium

N.V. GRUNDFOS Bellux S.A.
Boomssesteenweg 81-83
B-2630 Aartselaar
Tel.: +32-3-870 7300
Fax: +32-3-870 7301

Bosnia and Herzegovina

GRUNDFOS Sarajevo
Zmajia od Bosne 7-7A
BiH-71000 Sarajevo
Tel.: +387 33 592 480
Fax: +387 33 590 465
www.ba.grundfos.com
E-mail: grundfos@bih.net.ba

Brazil

BOMBAS GRUNDFOS DO BRASIL
Av. Humberto de Alencar Castelo
Branco, 630
CEP 09850 - 300
São Bernardo do Campo - SP
Tel.: +55-11 4393 5533
Fax: +55-11 4343 5015

Bulgaria

Grundfos Bulgaria EOOD
Slatina District
Iztocna Tangenta street no. 100
BG - 1592 Sofia
Tel.: +359 2 49 22 200
Fax: +359 2 49 22 201
E-mail: bulgaria@grundfos.bg

Canada

GRUNDFOS Canada inc.
2941 Brighton Road
Oakville, Ontario
L6H 6C9
Tel.: +1-905 829 9533
Fax: +1-905 829 9512

China

GRUNDFOS Pumps (Shanghai) Co. Ltd.
10F The Hub, No. 33 Suhong Road
Minhang District
Shanghai 201106 PRC
Tel.: +86 21 612 252 22
Fax: +86 21 612 253 33

Colombia

GRUNDFOS Colombia S.A.S.
Km 1.5 vía Siberia-Cota Conj. Potrero
Chico,
Parque Empresarial Arcos de Cota Bo. 1A.
Cota, Cundinamarca
Tel.: +57(1)-2913444
Fax: +57(1)-8764586

Croatia

GRUNDFOS CROATIA d.o.o.
Buzinski prilaz 38, Buzin
HR-10010 Zagreb
Tel.: +385 1 6595 400
Fax: +385 1 6595 499
www.hr.grundfos.com

Czech Republic

GRUNDFOS Sales Czechia and Slovakia
s.r.o.
Čajkovského 21
779 00 Olomouc
Tel.: +420-585-716 111

Denmark

GRUNDFOS DK A/S
Martin Bachs Vej 3
DK-8850 Bjerringbro
Tel.: +45-87 50 50 50
Fax: +45-87 50 51 51
E-mail: info_GDK@grundfos.com
www.grundfos.com/DK

Estonia

GRUNDFOS Pumps Eesti OÜ
Peterburi tee 92G
11415 Tallinn
Tel.: + 372 606 1690
Fax: + 372 606 1691

Finland

OY GRUNDFOS Pumput AB
Trukkikujua 1
FI-01360 Vantaa
Tel.: +358-(0) 207 889 500

France

Pompes GRUNDFOS Distribution S.A.
Parc d'Activités de Chesnes
57, rue de Malacombe
F-38290 St. Quentin Fallavier (Lyon)
Tel.: +33-4 74 82 15 15
Fax: +33-4 74 94 10 51

Germany

GRUNDFOS GMBH
Schlüterstr. 33
40699 Erkrath
Tel.: +49-(0) 211 929 69-0
Fax: +49-(0) 211 929 69-3799
E-mail: infoservice@grundfos.de
Service in Deutschland:
kundendienst@grundfos.de

Greece

GRUNDFOS Hellas A.E.B.E.
20th km. Athinon-Markopoulou Av.
P.O. Box 71
GR-19002 Peania
Tel.: +0030-210-66 83 400
Fax: +0030-210-66 46 273

Hong Kong

GRUNDFOS Pumps (Hong Kong) Ltd.
Unit 1, Ground floor, Siu Wai industrial
Centre
29-33 Wing Hong Street & 68 King Lam
Street, Cheung Sha Wan
Kowloon
Tel.: +852-27861706 / 27861741
Fax: +852-27858664

Hungary

GRUNDFOS South East Europe Kft.
Tópark u. 8
H-2045 Törökbálint
Tel.: +36-23 511 110
Fax: +36-23 511 111

India

GRUNDFOS Pumps India Private
Limited
118 Old Mahabalipuram Road
Thoraiappakam
Chennai 600 097
Tel.: +91-44 2496 6800

Indonesia

PT GRUNDFOS Pompa
Graha intrub Lt. 2 & 3
Jln. Cililitan Besar No.454. Makasar,
Jakarta Timur
ID-Jakarta 13650
Tel.: +62 21-469-51900
Fax: +62 21-460 6910 / 460 6901

Ireland

GRUNDFOS (Ireland) Ltd.
Unit A, Merrywell Business Park
Ballymount Road Lower
Dublin 12
Tel.: +353-1-4089 800
Fax: +353-1-4089 830

Italy

GRUNDFOS Pompe Italia S.r.l.
Via Gran Sasso 4
I-20060 Truccazzano (Milano)
Tel.: +39-02-95838112
Fax: +39-02-95309290 / 95838461

Japan

GRUNDFOS Pumps K.K.
1-2-3, Shin-Miyakoda, Kita-ku
Hamamatsu
431-2103 Japan
Tel.: +81 53 428 4760
Fax: +81 53 428 5005

Kazakhstan

Grundfos Kazakhstan LLP
7' Kyz-Zhibek Str., Kok-Tobe micr.
KZ-050020 Almaty Kazakhstan
Tel.: +7 (727) 227-98-55/56

Korea

GRUNDFOS Pumps Korea Ltd.
6th Floor, Aju Building 679-5
Yeoksam-dong, Kangnam-ku, 135-916
Seoul, Korea
Tel.: +82-2-5317 600
Fax: +82-2-5633 725

Latvia

SIA GRUNDFOS Pumps Latvia
Deglava biznesa centrs
Augusta Deglava ielā 60
LV-1035, Rīga,
Tel.: + 371 714 9640, 7 149 641
Fax: + 371 914 9646

Lithuania

GRUNDFOS Pumps UAB
Smolensko g. 6
LT-03201 Vilnius
Tel.: +370 52 395 430
Fax: +370 52 395 431

Malaysia

GRUNDFOS Pumps Sdn. Bhd.
7 Jalan Peguam U1/25
Glenmarie Industrial Park
40150 Shah Alam, Selangor
Tel.: +60-3-5569 2922
Fax: +60-3-5569 2866

Mexico

Bombas GRUNDFOS de México
S.A. de C.V.
Boulevard TLC No. 15
Parque industrial Stiva Aeropuerto
Apodaca, N.L. 66600
Tel.: +52-81-8144 4000
Fax: +52-81-8144 4010

Netherlands

GRUNDFOS Netherlands
Veluwezoom 35
1326 AE Almere
Postbus 22015
1302 CA ALMERE
Tel.: +31-88-478 6336
Fax: +31-88-478 6332
E-mail: info_gnl@grundfos.com

New Zealand

GRUNDFOS Pumps NZ Ltd.
17 Beatrice Tinsley Crescent
North Harbour Industrial Estate
Albany, Auckland
Tel.: +64-9-415 3240
Fax: +64-9-415 3250

Norway

GRUNDFOS Pumper A/S
Strømsveien 344
Postboks 235, Leirdal
N-1011 Oslo
Tel.: +47-22 90 47 00
Fax: +47-22 32 21 50

Poland

GRUNDFOS Pompy Sp. z o.o.
ul. Klonowa 23
Baranowo k. Poznania
PL-62-081 Przeźmierowo
Tel.: (+48-61) 650 13 00
Fax: (+48-61) 650 13 50

Portugal

Bombas GRUNDFOS Portugal, S.A.
Rua Calvet de Magalhães, 241
Apartado 1079
P-2770-153 Paço de Arcos
Tel.: +351-21-440 76 00
Fax: +351-21-440 76 90

Romania

GRUNDFOS Pompe România SRL
S-PARK BUSINESS CENTER, Clădirea
A2, etaj 2
Str. Tipografilor, Nr. 11-15, Sector 1, Cod
013714
Bucuresti, Romania
Tel.: 004 021 2004 100
E-mail: romania@grundfos.ro

Serbia

Grundfos Srbija d.o.o.
Orladijskih brigada 90b
11070 Novi Beograd
Tel.: +381 11 2258 740
Fax: +381 11 2281 769
www.rs.grundfos.com

Singapore

GRUNDFOS (Singapore) Pte. Ltd.
25 Jalan Tukang
Singapore 619264
Tel.: +65-6681 9688
Fax: +65-6681 9689

Slovakia

GRUNDFOS s.r.o.
Prievozská 4D 821 09 BRATISLAVA
Tel.: +421 2 5020 1426
sk.grundfos.com

Slovenia

GRUNDFOS LJUBLJANA, d.o.o.
Leskoškova 9e, 1122 Ljubljana
Tel.: +386 (0) 1 568 06 10
Fax: +386 (0) 1 568 06 19
E-mail: tehnika-si@grundfos.com

South Africa

GRUNDFOS (PTY) LTD
16 Lascelles Drive, Meadowbrook Estate
1609 Germiston, Johannesburg
Tel.: (+27) 10 248 6000
Fax: (+27) 10 248 6002
E-mail: lgradidge@grundfos.com

Spain

Bombas GRUNDFOS España S.A.
Camino de la Fuentecilla, s/n
E-28110 Algete (Madrid)
Tel.: +34-91-848 8800
Fax: +34-91-628 0465

Sweden

GRUNDFOS AB
Box 333 (Lunnagårdsgatan 6)
431 24 Mölndal
Tel.: +46 31 332 23 000
Fax: +46 31 331 94 60

Switzerland

GRUNDFOS Pumpen AG
Bruggacherstrasse 10
CH-8117 Fällanden/ZH
Tel.: +41-44-806 8111
Fax: +41-44-806 8115

Taiwan

GRUNDFOS Pumps (Taiwan) Ltd.
7 Floor, 219 Min-Chuan Road
Taichung, Taiwan, R.O.C.
Tel.: +886-4-2305 0868
Fax: +886-4-2305 0878

Thailand

GRUNDFOS (Thailand) Ltd.
92 Chaloe Phrakiat Rama 9 Road
Dokmai, Pravej, Bangkok 10250
Tel.: +66-2-725 8999
Fax: +66-2-725 8998

Turkey

GRUNDFOS POMPA San. ve Tic. Ltd.
Sti.
Gebze Organize Sanayi Bölgesi
Ihsan dede Caddesi
2. yol 200, Sokak No. 204
41490 Gebze/ Kocaeli
Tel.: +90 - 262-679 7979
Fax: +90 - 262-679 7905
E-mail: satis@grundfos.com

Ukraine

ТОВ "ГРУНДФОС УКРАЇНА"
Бізнес Центр Європа
Столичне шосе, 103
м. Київ, 03131, Україна
Tel.: (+38 044) 237 04 00
Fax: (+38 044) 237 04 01
E-mail: ukraine@grundfos.com

United Arab Emirates

GRUNDFOS Gulf Distribution
P.O. Box 16768
Jebel Ali Free Zone, Dubai
Tel.: +971 4 8815 166
Fax: +971 4 8815 136

United Kingdom

GRUNDFOS Pumps Ltd.
Grovebury Road
Leighton Buzzard/Beds. LU7 4TL
Tel.: +44-1525-850000
Fax: +44-1525-850011

U.S.A.

Global Headquarters for WU
856 Koomey Road
Brookshire, Texas 77423 USA
Phone: +1-630-236-5500

Uzbekistan

Grundfos Tashkent, Uzbekistan
The Representative Office of Grundfos
Kazakhstan in Uzbekistan
38a, Oybek street, Tashkent
Tel.: (+998) 71 150 3290 / 71 150 3291
Fax: (+998) 71 150 3292

92852550 06.2025

ECM: 1425131

www.grundfos.com

GRUNDFOS 

Trademarks displayed in this material, including but not limited to Grundfos and the Grundfos logo, are registered trademarks owned by The Grundfos Group. © 2025 Grundfos Holding A/S, all rights reserved.