

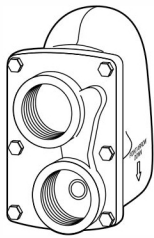

# Hoffman Specialty<sup>®</sup> Float and Thermostatic Traps Series H, C and X

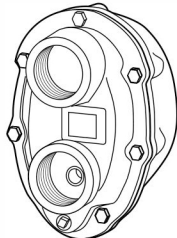

**Series C**  
1 1/4 & 1 1/2 NPT



**Series C**  
2 NPT

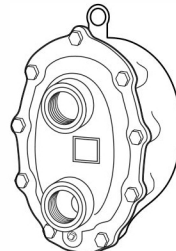

**Series X**  
2 NPT

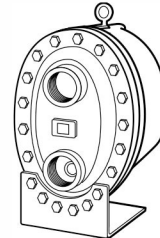

**Series C**  
2 1/2 NPT

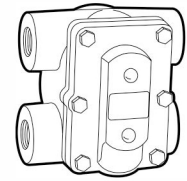

**Series H**

Ratings		
NPT Size - in.	Maximum Temperature °F (°C)	Max. Operating Pressure psig (bar)
3/4", 1" and 1 1/4" H	406 (208)	175 (12.1)
1 1/4" C and All 1 1/2" - 2 1/2"	377 (192)	



## **WARNING**



- Before using product, read and understand instructions.
- Save these instructions for future reference.



- All work must be performed by qualified personnel trained in the proper application, installation, and maintenance of steam systems in accordance with all applicable codes and ordinances.

- To prevent serious burns, wear heat resistant gloves when opening and closing steam valves, or handling hot equipment.
- To prevent serious burns, the internal pressure of the trap must be 0 psi (0 bar) before servicing.



- To prevent serious personal injury from steam pipe blow down, connect a temporary pipe between the steam pipe opening and a drain, or stand at least 100 ft. (30 m) from the front of the pipe opening.



- To prevent property damage, personal injury, or death, cap off the gate valves if they are not connected to a drain and when they are not in use for test or pressure relief.

- This product can expose you to chemicals including Lead, which is known to the State of California to cause cancer and birth defects or other reproductive harm. For more information go to: [www.P65Warnings.ca.gov](http://www.P65Warnings.ca.gov).

Failure to follow this warning could cause property damage, personal injury or death.



# OPERATION

Float and thermostatic traps have two basic elements: a thermostat for venting air from the system during start-up and a float assembly for draining condensate.

The thermostat is normally open. It allows air to vent until it is within 10-30°F (4-12°C) of the steam temperature.

The float assembly drains condensate from the system when buoyancy force lifts the float ball and opens the valve. The weight of the float ball causes the pin to close against the trap seat when condensate is not present.

Materials of Construction	
Part	Specifications
Body and Cover	Cast Iron 30,000 psi tensile
Valve Pin and Seat	Stainless Steel (Hardened)
Float	Stainless Steel
Lever Assembly	Stainless Steel
Thermostatic Air Vent	Stainless Steel Cage and Thermal Element
Cover Bolts	Grade 5
Baffle	Stainless Steel {2 1/2" units only}

	<p><b>WARNING</b></p> <p>To prevent serious personal injury from steam pipe blow down, connect a temporary pipe between the steam pipe opening and a drain, or stand at least 100 ft. (30m) from the pipe opening.</p>
	<p>Failure to follow this warning could cause property damage, personal injury, or death.</p>

# INSTALLATION – Series H, C and X Float and Thermostatic Steam Traps

## STEP 1

- Determine where to install the trap, based on the following requirements:
  - The trap must be located as close as possible to, and below the equipment to be drained.
  - The trap must be in a straight run of horizontal pipe as shown in the “Typical Piping Diagrams,” and pitched to allow condensate to flow into trap inlet, and away from trap outlet.
  - Allow for enough space around the trap for servicing, which may include removal of the body or cover, depending on the model you are installing.

The Hoffman Series H traps provide an additional opening where a test valve may be installed. On traps that do not have an additional opening, the test valve can be installed in a tee fitting in the discharge line.

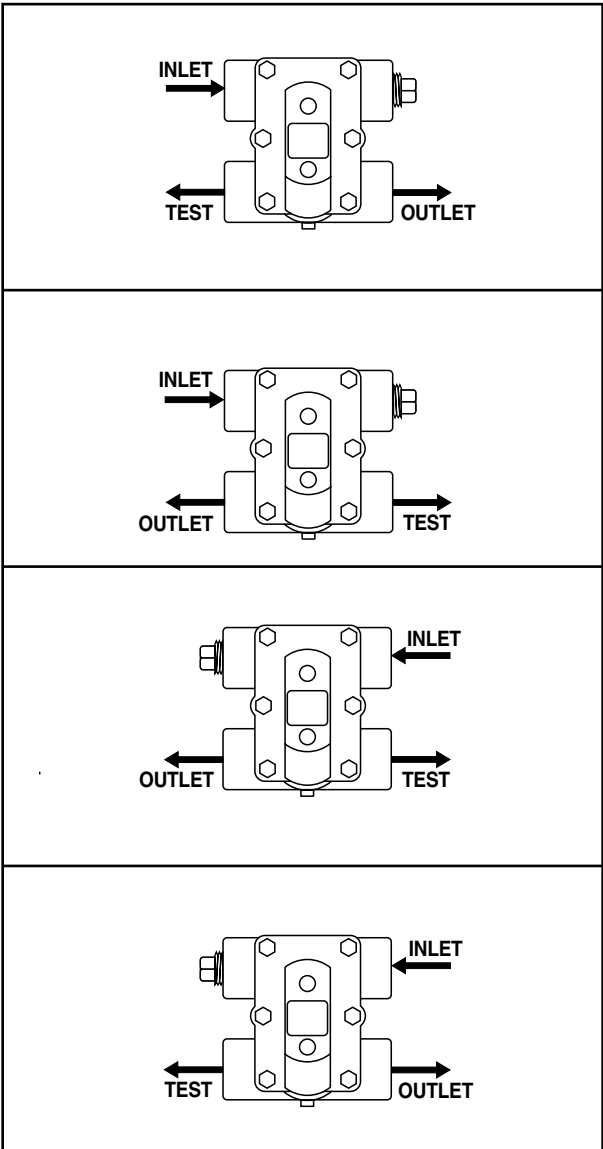

## STEP 2

**IMPORTANT:** To prevent system damage from water hammer or sudden shock, open supply valves slowly.

If you are uncertain about the product's adaptability for your application, please call the factory or authorized representative before using the product.

The trap seat rating (stamped on the nameplate) must be equal to or greater than the maximum pressure differential across the trap.

- Install a Hoffman Specialty Y-strainer in the pipe, ahead of the steam trap. This prevents dirt from entering the trap.
- Install a blow down valve by connecting it to the strainer drain plug. This allows the Y-strainer to be cleaned.
- Install a shut-off valve in the inlet pipe and the outlet pipe. This allows the trap to be isolated when servicing.
- Install a test valve in the outlet pipe, and cap it. This allows the trap to be tested. The cap is used as safety precaution when the unit is not being tested.
- Blow down the piping using full steam pressure for (5) five minutes. This cleaning process will remove debris from the pipe and oil from the system.

Test traps by following the "Troubleshooting" procedure on page 6.

## TYPICAL PIPING DIAGRAMS

### Series H Trap Draining to Gravity Return Line

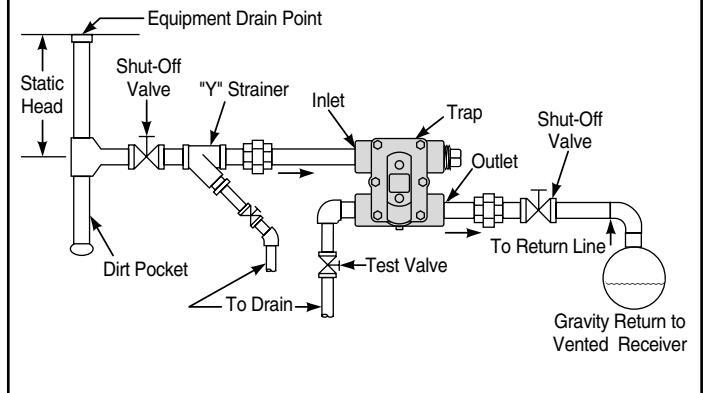

### Series C and X Pattern Trap Installations

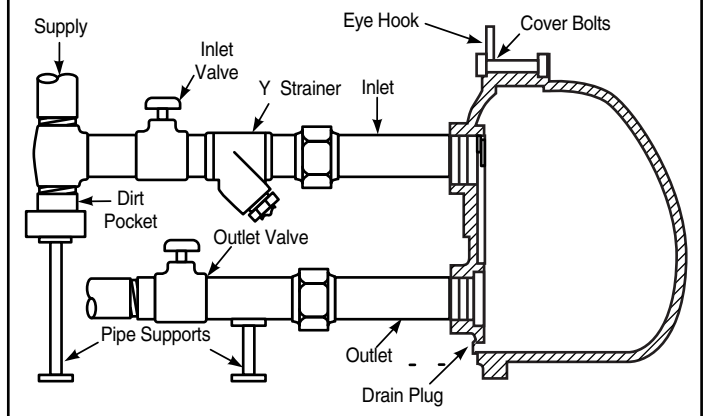

### 2½" Series C Pattern Trap Installations

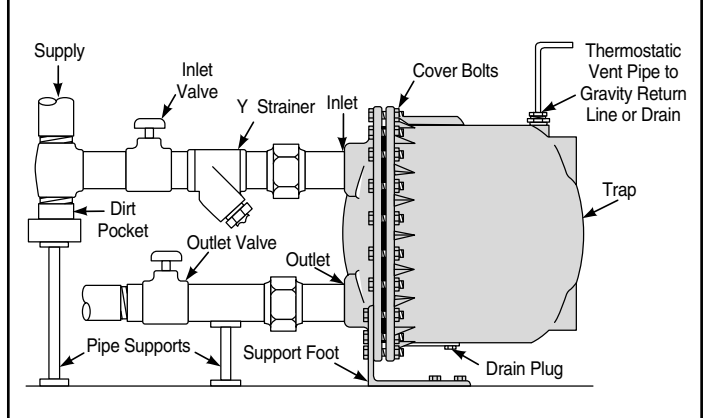

	<p><b>WARNING</b></p>
	<p>To prevent serious personal injury from steam pipe blow down, connect a temporary pipe between the steam pipe opening and a drain, or stand at least 100 ft. (30m) from the pipe opening.</p> <p>Failure to follow this warning could cause property damage, personal injury, or death.</p>

## REPAIR PROCEDURES FOR ALL TRAPS

### REMOVAL FROM SERVICE

1. Close inlet and outlet supply valves and allow unit to cool. If a test valve is installed, open this valve to relieve any pressure.
2. Remove the drain plug to drain condensate from the trap body.
3. Remove the bolts that attach the cover to the body.

### SERIES H TRAPS

#### REPAIR

4. With cover assembly removed from trap body, remove pin that holds lever assembly to yoke. Inspect seat and pin for wear, replace if worn.
5. Inspect thermostatic element by placing it in boiling water to see if it closes. If it doesn't close, replace it.
6. Check alignment of pin and seat, adjust or replace parts as necessary.
7. Check float ball for damage, shake the float to make sure there is no fluid inside the float. Replace if necessary.
8. Clean gasket surfaces and install new cover gasket.
9. Reassemble the cover to the body. Tighten the bolts in the indicated sequence shown on page 5. Torque all bolts evenly to the indicated values.

### SERIES C & X TRAPS

#### REPAIR

4. With body assembly removed from trap cover, remove pin that holds lever assembly to yoke. Inspect seat and pin for wear, replace if worn.
5. Inspect thermostatic element by placing it in boiling water to see if it closes. If it doesn't close, replace it.
6. Check alignment of pin and seat, adjust or replace parts as necessary.
7. Check float ball for damage, shake the float to make sure there is no fluid inside the float. Replace if necessary.
8. Clean gasket surfaces and install new cover gasket.
9. Reassemble the body to the cover. Tighten the bolts in the indicated sequence shown on page 5. Torque all bolts evenly to the indicated values.

### CAUTION

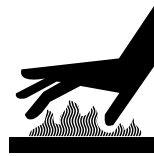

To prevent serious burns, the internal pressure of the trap must be 0 psi (0 bar) before servicing.

Failure to follow this caution will cause personal injury.

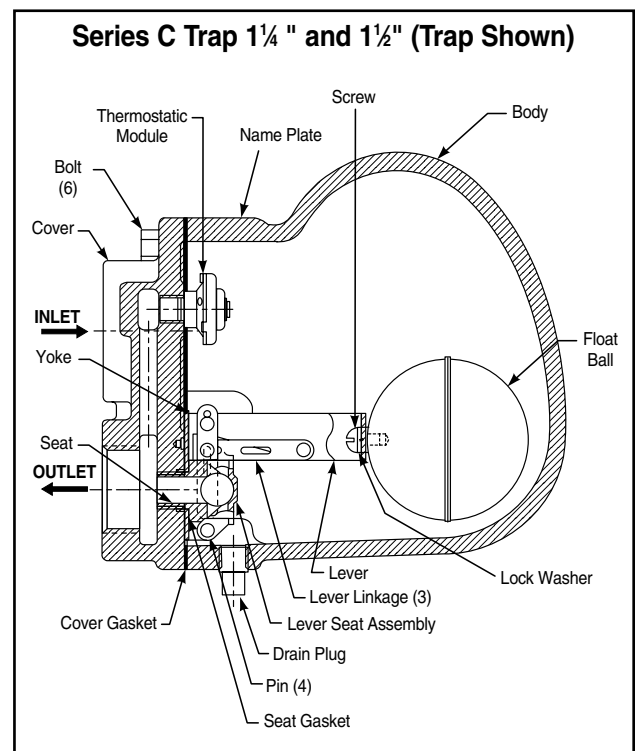
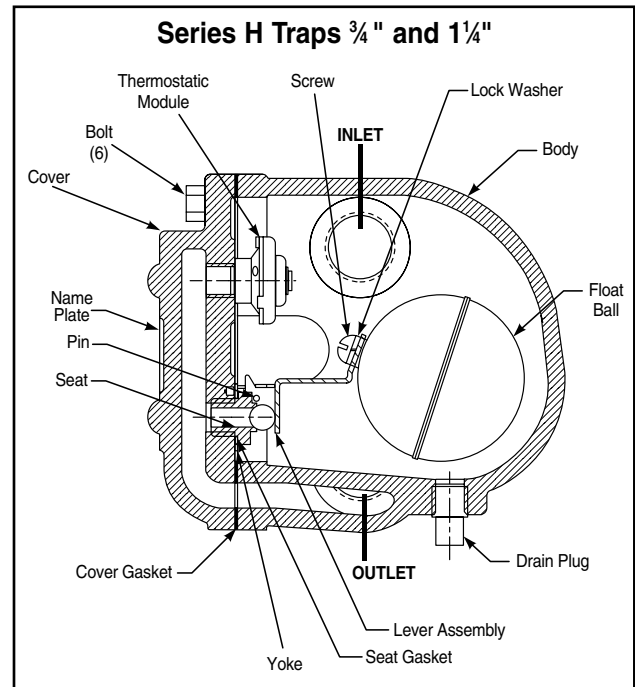

## Internal Component Detail Illustration

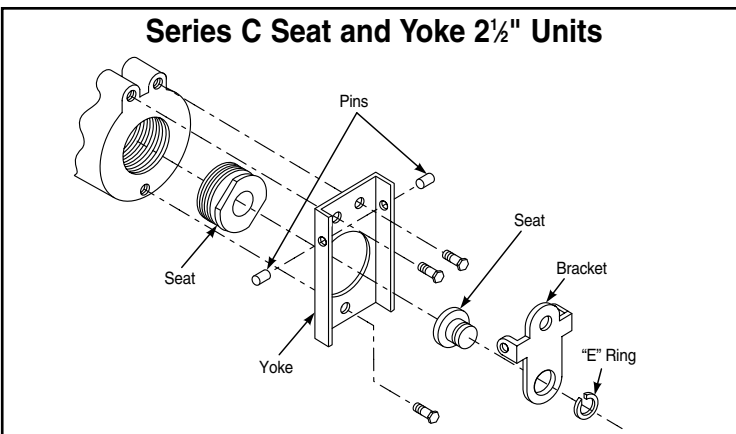
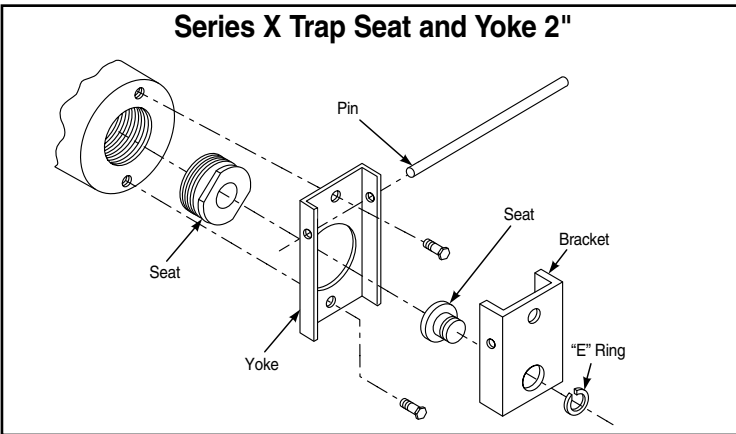
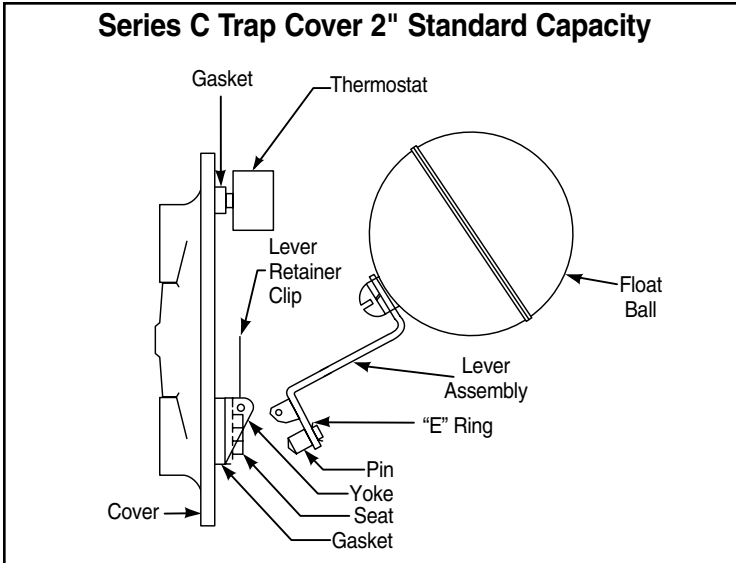

### RETURN TO SERVICE



10. Insert and securely tighten drain plug.
  11. Open supply valve on trap outlet side, slowly open the supply valve to the trap inlet.
  12. Check for leaks and normal operation.
- Test traps by following the "Troubleshooting" procedure on page 6.

## Cover Bolt Pattern Layout

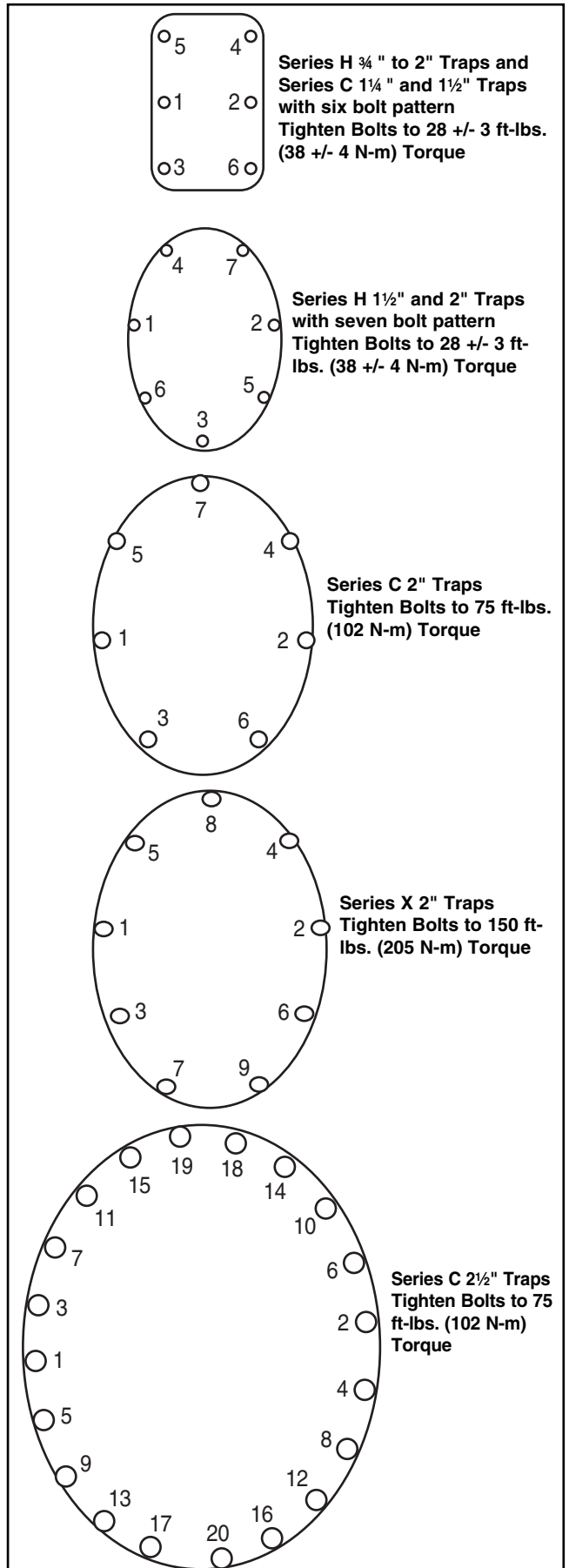
Tighten and torque bolts in numerical order, beginning with #1.





## MAINTENANCE

	<p><b>WARNING</b></p>
	<p>To prevent serious personal injury from steam pipe blow down, connect a temporary pipe between the steam pipe opening and a drain, or stand at least 100 ft. (30m) from the pipe opening.</p> <p>Failure to follow this warning could cause property damage, personal injury, or death.</p>

When checked regularly and properly maintained, the Series FT Float and Thermostatic traps will provide optimum performance and long life.

### SCHEDULE:

- Initially, every 2 - 3 days after start-up until system is clean.
- Every 6 months thereafter.

	<p><b>CAUTION</b></p>
	<p>To prevent serious burns, the internal pressure of the trap must be 0 psi (0 bar) before servicing.</p> <p>Failure to follow this caution will cause personal injury.</p>

1. Inspect joints for leaks. Stop all leaks by tightening bolts and replacing gaskets, if necessary.
2. Clean strainers by opening the blow down valve and allowing full steam pressure to flow out for (2) two minutes. Then, close the valve.

## TROUBLESHOOTING

Problem:

### 1. Improper heating.

- a. **Cause:** Thermostat failed closed and prevents air from escaping.  
**Test:** Blow air through the thermostat when it is at normal room temperature, for a visual check. If air does not pass through, the thermostat is not functioning properly.
- b. **Cause:** Float assembly failed closed and caused condensate to back-up into the steam space.  
**Test:** Using a stethoscope, listen for a gurgling sound. No gurgling indicates that condensate is not draining.

**OR**

Using a thermometer, check the trap discharge temperature. If the temperature is lower than normal, the condensate is not draining.

- c. **Cause:** Incorrect trap seat pressure selected.  
**Test:** Check seat pressure rating on trap nameplate. The seat pressure rating must be equal or higher than the steam supply pressure.

### 2. Energy wasted.

- a. **Cause:** Thermostat failed open and allowed live steam to blow through the trap.  
**Test:** Using a stethoscope, listen for a low pitch whistle as steam passes through the open orifice. A whistle indicates the thermostat failed open.
- b. **Cause:** Float assembly failed open and allowed live steam to blow through the trap.  
**Test:** Install a test valve in the discharge line from the trap outlet. Observe the trap operation for steam leakage. Excessive steam leakage indicates the float assembly failed open.

**OR**

Using a stethoscope, listen for a low pitch whistle by positioning the stethoscope near the thermostat or the float assembly. A whistle indicates the thermostat or float assembly (depending on where the stethoscope is positioned) failed open.

## **COMMERCIAL WARRANTY**

**Warranty.** For goods sold to commercial buyers, Seller warrants the goods sold to Buyer hereunder (with the exception of membranes, seals, gaskets, elastomer materials, coatings and other “wear parts” or consumables all of which are not warranted except as otherwise provided in the quotation or sales form) will be (i) be built in accordance with the specifications referred to in the quotation or sales form, if such specifications are expressly made a part of this Agreement, and (ii) free from defects in material and workmanship for a period of one (1) year from the date of installation or two (2) years from the date of manufacture, whichever shall occur first, unless a longer period is specified in the product documentation (the “Warranty”).

Except as otherwise required by law, Seller shall, at its option and at no cost to Buyer, either repair or replace any product which fails to conform with the Warranty provided Buyer gives written notice to Seller of any defects in material or workmanship within ten (10) days of the date when any defects or non-conformance are first manifest. Under either repair or replacement option, Seller shall not be obligated to remove or pay for the removal of the defective product or install or pay for the installation of the replaced or repaired product and Buyer shall be responsible for all other costs, including, but not limited to, service costs, shipping fees and expenses. Seller shall have sole discretion as to the method or means of repair or replacement. Buyer’s failure to comply with Seller’s repair or replacement directions shall terminate Seller’s obligations under this Warranty and render the Warranty void. Any parts repaired or replaced under the Warranty are warranted only for the balance of the warranty period on the parts that were repaired or replaced. Seller shall have no warranty obligations to Buyer with respect to any product or parts of a product that have been: (a) repaired by third parties other than Seller or without Seller’s written approval; (b) subject to misuse, misapplication, neglect, alteration, accident, or physical damage; (c) used in a manner contrary to Seller’s instructions for installation, operation and maintenance; (d) damaged from ordinary wear and tear, corrosion, or chemical attack; (e) damaged due to abnormal conditions, vibration, failure to properly prime, or operation without flow; (f) damaged due to a defective power supply or improper electrical protection; or (g) damaged resulting from the use of accessory equipment not sold or approved by Seller. In any case of products not manufactured by Seller, there is no warranty from Seller; however, Seller will extend to Buyer any warranty received from Seller’s supplier of such products.

**THE FOREGOING WARRANTY IS EXCLUSIVE AND IN LIEU OF ANY AND ALL OTHER EXPRESS OR IMPLIED WARRANTIES, GUARANTEES, CONDITIONS OR TERMS OF WHATEVER NATURE RELATING TO THE GOODS PROVIDED HEREUNDER, INCLUDING WITHOUT LIMITATION ANY IMPLIED WARRANTIES OF MERCHANTABILITY AND FITNESS FOR A PARTICULAR PURPOSE, WHICH ARE HEREBY EXPRESSLY DISCLAIMED AND EXCLUDED. EXCEPT AS OTHERWISE REQUIRED BY LAW, BUYER’S EXCLUSIVE REMEDY AND SELLER’S AGGREGATE LIABILITY FOR BREACH OF ANY OF THE FOREGOING WARRANTIES ARE LIMITED TO REPAIRING OR REPLACING THE PRODUCT AND SHALL IN ALL CASES BE LIMITED TO THE AMOUNT PAID BY THE BUYER FOR THE DEFECTIVE PRODUCT. IN NO EVENT SHALL SELLER BE LIABLE FOR ANY OTHER FORM OF DAMAGES, WHETHER DIRECT, INDIRECT, LIQUIDATED, INCIDENTAL, CONSEQUENTIAL, PUNITIVE, EXEMPLARY OR SPECIAL DAMAGES, INCLUDING BUT NOT LIMITED TO LOSS OF PROFIT, LOSS OF ANTICIPATED SAVINGS OR REVENUE, LOSS OF INCOME, LOSS OF BUSINESS, LOSS OF PRODUCTION, LOSS OF OPPORTUNITY OR LOSS OF REPUTATION.**

## **LIMITED CONSUMER WARRANTY**

**Warranty.** For goods sold for personal, family or household purposes, Seller warrants the goods purchased hereunder (with the exception of membranes, seals, gaskets, elastomer materials, coatings and other “wear parts” or consumables all of which are not warranted except as otherwise provided in the quotation or sales form) will be free from defects in material and workmanship for a period of one (1) year from the date of installation or two (2) years from the product date code, whichever shall occur first, unless a longer period is provided by law or is specified in the product documentation (the “Warranty”).

Except as otherwise required by law, Seller shall, at its option and at no cost to Buyer, either repair or replace any product which fails to conform with the Warranty provided Buyer gives written notice to Seller of any defects in material or workmanship within ten (10) days of the date when any defects or non-conformance are first manifest. Under either repair or replacement option, Seller shall not be obligated to remove or pay for the removal of the defective product or install or pay for the installation of the replaced or repaired product and Buyer shall be responsible for all other costs, including, but not limited to, service costs, shipping fees and expenses. Seller shall have sole discretion as to the method or means of repair or replacement. Buyer's failure to comply with Seller's repair or replacement directions shall terminate Seller's obligations under this Warranty and render this Warranty void. Any parts repaired or replaced under the Warranty are warranted only for the balance of the warranty period on the parts that were repaired or replaced. The Warranty is conditioned on Buyer giving written notice to Seller of any defects in material or workmanship of warranted goods within ten (10) days of the date when any defects are first manifest.

Seller shall have no warranty obligations to Buyer with respect to any product or parts of a product that have been: (a) repaired by third parties other than Seller or without Seller's written approval; (b) subject to misuse, misapplication, neglect, alteration, accident, or physical damage; (c) used in a manner contrary to Seller's instructions for installation, operation and maintenance; (d) damaged from ordinary wear and tear, corrosion, or chemical attack; (e) damaged due to abnormal conditions, vibration, failure to properly prime, or operation without flow; (f) damaged due to a defective power supply or improper electrical protection; or (g) damaged resulting from the use of accessory equipment not sold or approved by Seller. In any case of products not manufactured by Seller, there is no warranty from Seller; however, Seller will extend to Buyer any warranty received from Seller's supplier of such products.

**THE FOREGOING WARRANTY IS PROVIDED IN PLACE OF ALL OTHER EXPRESS WARRANTIES. ALL IMPLIED WARRANTIES, INCLUDING BUT NOT LIMITED TO THE IMPLIED WARRANTIES OF MERCHANTABILITY AND FITNESS FOR A PARTICULAR PURPOSE, ARE LIMITED TO ONE (1) YEAR FROM THE DATE OF INSTALLATION OR TWO (2) YEARS FROM THE PRODUCT DATE CODE, WHICHEVER SHALL OCCUR FIRST. EXCEPT AS OTHERWISE REQUIRED BY LAW, BUYER'S EXCLUSIVE REMEDY AND SELLER'S AGGREGATE LIABILITY FOR BREACH OF ANY OF THE FOREGOING WARRANTIES ARE LIMITED TO REPAIRING OR REPLACING THE PRODUCT AND SHALL IN ALL CASES BE LIMITED TO THE AMOUNT PAID BY THE BUYER FOR THE DEFECTIVE PRODUCT. IN NO EVENT SHALL SELLER BE LIABLE FOR ANY OTHER FORM OF DAMAGES, WHETHER DIRECT, INDIRECT, LIQUIDATED, INCIDENTAL, CONSEQUENTIAL, PUNITIVE, EXEMPLARY OR SPECIAL DAMAGES, INCLUDING BUT NOT LIMITED TO LOSS OF PROFIT, LOSS OF ANTICIPATED SAVINGS OR REVENUE, LOSS OF INCOME, LOSS OF BUSINESS, LOSS OF PRODUCTION, LOSS OF OPPORTUNITY OR LOSS OF REPUTATION.**

Some states do not allow limitations on how long an implied warranty lasts, so the above limitation may not apply to you. Some states do not allow the exclusion or limitation of incidental or consequential damages, so the above exclusions may not apply to you. This warranty gives you specific legal rights, and you may also have other rights which may vary from state to state.

To make a warranty claim, check first with the dealer from whom you purchased the product or call +1-847-966-3700 for the name and location of the nearest dealer providing warranty service.



Xylem Inc.  
8200 N. Austin Avenue  
Morton Grove, Illinois 60053  
Phone: (847) 966-3700  
Fax: (847) 965-8379  
[www.xylem.com/bellgossett](http://www.xylem.com/bellgossett)

Bell & Gossett is a trademark of Xylem Inc. or one of its subsidiaries.  
© 2019 Xylem Inc. HS-222H May 2019 Part No. 510837

