

uponor

Piping systems installation guide



Piping systems installation guide

is published by

Uponor Inc.

5925 148th Street West
Apple Valley, MN 55124
USA

T 800.321.4739

F 952.891.2008

Uponor Ltd.

6510 Kennedy Road
Mississauga, ON L5T 2X4
CANADA

T 888.994.7726

F 800.638.9517

uponorpro.com

uponorengineering.com

© 2019 Uponor, All rights reserved.

Printed in the United States of America

This piping systems installation guide is published for mechanical contractors, installers and building officials interested in Uponor PEX piping systems. It describes general installation recommendations that use Uponor PEX piping products. Refer to local codes for additional requirements.

Uponor made reasonable efforts to collect, prepare and provide quality information and material in this installation guide. However, system enhancements may result in modification of features or specifications without notice.

Uponor is not liable for installation practices that deviate from this installation guide or are not acceptable practices within the mechanical trades, codes or standards of practice.

Prior to installing Uponor piping systems, Uponor recommends all installers attend Uponor piping systems installation training performed by an Uponor trainer or manufacturer's representative. To schedule a training session at your business or job site, contact your local Uponor representative or call 800.321.4739.

Direct any questions regarding the suitability of an application or a specific design to a local Uponor representative by calling 888.594.7726 (U.S.) or 888.994.7726 (Canada).

Table of contents

| | |
|--|----|
| Important safety information | ii |
| Standards, codes and listings | 1 |
| Making a ProPEX® connection | 1 |
| Cutting large-diameter PEX pipe | 6 |
| Troubleshooting a ProPEX connection | 7 |
| Verifying ProPEX connections | 8 |
| Minimum distance between fittings | 8 |
| Bending PEX | 9 |
| Uponor PEX ultraviolet (UV) resistance ratings | 10 |
| Storing and handling guidelines | 10 |
| Supporting Uponor PEX pipe | 12 |
| Supporting Uponor multiport tees | 13 |
| Strapping | 15 |
| Bundling | 15 |
| Main/corridor straight-length piping | 16 |
| Expansion and contraction | 17 |
| Installing Uponor PEX-a Pipe Support | 19 |
| Supporting large-diameter valves | 23 |
| Vertical support requirements | 24 |
| Risers | 27 |
| Fire-resistant construction | 29 |
| Below-grade installation | 38 |
| In-slab installation | 39 |
| Pressure testing | 40 |
| Water system disinfection | 41 |

Table of contents

| | |
|--|----|
| Appendix A: Dimensions and physical characteristics of Uponor PEX pipe | 42 |
| Appendix B: Hydrostatic temperature and pressure ratings. | 43 |
| Appendix C: ProPEX fitting dimensions | 45 |
| Appendix D: Uponor piping systems installation test questions | 75 |

Important safety information

To reduce the risk of injury, read and understand this piping systems installation guide before beginning work.

Read all product safety warnings and operator's manuals for the Milwaukee® Tool M12™, M18™ and FORCE LOGIC™ ProPEX expansion tools, ProPEX 201 corded expander tool, PEX pipe cutters and other installation tools to operate those tools safely and correctly.

Always wear safety goggles or safety glasses with side shields when performing work.



WARNING: Cancer and Reproductive Harm
www.P65Warnings.ca.gov

Standards, codes and listings

Uponor PEX pipe and ProPEX fittings are designed to all applicable industry standards, codes and listings. Refer to our product submittals on uponorpro.com for complete details.

Making a ProPEX® connection

Important installation information

- Use only Milwaukee® ProPEX expander heads or Uponor standard expander heads on Milwaukee tools. Using incorrectly sized expansion heads may result in faulty connections which could result in leaking and property damage.
- Uponor standard expansion heads do not auto-rotate on Milwaukee ProPEX expansion tools. If using Uponor standard expansion heads, be sure to manually rotate the pipe or tool after each expansion to prevent deep grooves and faulty connections which could result in leaking and property damage.
- Ensure the Milwaukee expansion head is rotating during each expansion. This ensures no deep grooves on the inside of the pipe.
- Do not force the tool into the pipe.
- Improper lubrication (too much or too little) on the expansion cone and head may result in faulty connections which could result in leaking and property damage.
- Always remove the battery pack before changing or removing accessories, and only use accessories specifically recommended for the tool.
- Recharge only with the charger specified for the battery. For charging instructions, refer to the tool manual.



Figure 1: Expansion with proper rotation



Figure 2: Expansion without proper rotation

- To reduce risk of injury and damage, never immerse the tool, battery pack or charger in liquid or allow a liquid to flow inside the tool.
- Always unplug the charger and remove the battery pack from the charger or tool before performing any maintenance. Never disassemble the tool, battery pack or charger.
- Contact Milwaukee Tool at 800.SAWDUST (800.729.3878) for all service and repair work.



Figure 3: Milwaukee M12™ ProPEX expansion tool for 3/8" to 1" pipe

Figure 4: Milwaukee M18™ ProPEX expansion tool for 3/8" to 1 1/2" pipe

ProPEX connections with Milwaukee tools

Refer to the following steps to make ½" to 3" ProPEX connections. Each expansion tool features slight differences in operation. Use the Milwaukee M12 ProPEX expansion tool for ½" to 1" connections; use the Milwaukee M18 ProPEX expansion tool for ½" to 1½" connections.



Figure 5: Square cut the pipe.



Figure 6: Place the ProPEX ring over the end of the pipe.



Figure 7: Expand the pipe and ring until it reaches the collar. Then complete a minimum of one more expansion.



Figure 8: Insert the ProPEX fitting fully to the pipe stop.

Making ⅜" ProPEX connections

When making a ⅜" ProPEX connection, expand the ring once on each side to properly fit over the piping. Refer to the following instructions to make a ⅜" ProPEX connection.

1. Square cut the PEX piping perpendicular to the length of the piping. Remove all excess material or burrs that might affect the fitting connection.
2. Expand each side of the ring once.
3. Slide the expanded ring over the end of the piping. Extend the end of the ring over the end of the piping no more than ⅛" (1mm).
4. After the ring is on the piping, continue with the regular steps for making a proper connection with your specific tool.



Uponor ProPEX 201 corded expander tool

Use the ProPEX 201 corded expander tool to make 2" ProPEX connections.

Figure 9: ProPEX 201 tool

Note: The ProPEX 201 corded expander tool head does not manually rotate like the Milwaukee tool heads. It is important to properly rotate the pipe or tool after each expansion to prevent deep grooves in the piping. Failure to do so could result in leaking and property damage.

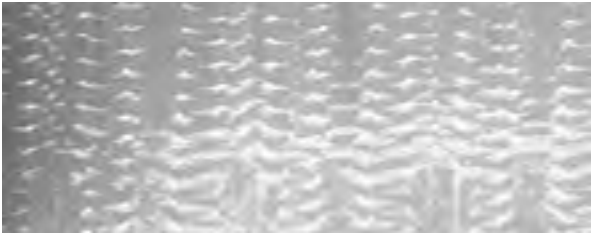

Figure 10: Expansion with proper rotation



Figure 11: Expansion without proper rotation

**Milwaukee M18
FORCE LOGIC™
ProPEX expansion tool**

Use the Milwaukee
M18 FORCE LOGIC
tool for 2" to 3" pipe.



**Figure 12: Milwaukee
M18 FORCE LOGIC
ProPEX expansion tool**



**Figure 13: When installing 2"- 3" heads, ensure
the cogs are aligned and engaged with the tool.**



**Figure 14: Expander head
collar should sit tight against
the tool.**



**Figure 15: If not installed
correctly, the expander
head will "flower".**

Cutting large-diameter PEX pipe



CAUTION: Read and thoroughly understand all safety instructions in the pipe cutter operator's manuals before performing work.



CAUTION: Be sure to wear safety gloves and proper eye protection prior to cutting pipe. Failure to do so could result in personal injury.

Use a swing or ratchet-type cutter to create smooth, clean cuts.



Figure 16: Uponor swing-style pipe cutter for up to 4" pipe (E6084000)



Figure 17: Uponor ratchet-style pipe cutter for up to 3" pipe (E6083000)

Troubleshooting a ProPEX connection

1. Ensure the expansion tool is properly maintained and in good working condition.
2. Ensure the expansion head is securely tightened onto the tool; frequently check that the head remains securely tightened throughout the installation process.
3. Ensure the segment fingers are not bent.
4. Remove excess grease.
5. Check the fitting for damage. Nicks and gouges will cause the fitting to leak.
6. Make sure the last expansion is not held in the expanded position before inserting the fitting.
7. Ensure proper rotation is occurring.
8. If a ProPEX ring slips, make sure that the outer pipe surface is clean and clear of any liquids. Inspect that the stop edge is present on the ProPEX ring.

Cold-weather expansions

Temperatures affect the time required for the piping and ring to shrink onto the fitting. Follow the below steps when making expansions in cold weather.

1. Warming the ProPEX fittings and ProPEX rings reduces contraction time. Put fittings and rings in your pockets prior to installation to keep them warm.
2. Make ProPEX connections at temperatures above 5°F (-15°C).
3. Fewer expansions are necessary in temperatures below 40°F (4.4°C).
4. Perform a test connection for each pipe size when temperatures differ from day to day, keeping note of the number of expansions to make a snug-fitting connection.

Verifying ProPEX connections

Ensure the ProPEX ring is tight against the fitting shoulder.



Figure 18: Coupling shoulder



Figure 19: Tee shoulder

Minimum distance between fittings

Uponor requires a minimum distance between ProPEX fittings to avoid damaging the fittings during installation and to protect against elevated stress on the pipe and fittings.

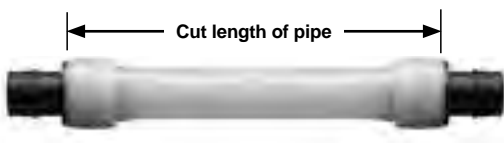

Figure 20: Minimum PEX length between fittings

Table 1: Minimum PEX cut length

| Pipe size | Minimum cut length of pipe |
|-----------|----------------------------|
| ½" | 2" (51mm) |
| ⅝" | 2½" (64mm) |
| ¾" | 3" (76mm) |
| 1" | 3½" (89mm) |
| 1¼" | 4½" (114mm) |
| 1½" | 4½" (114mm) |
| 2" | 6" (152mm) |
| 2½" | 7½" (191mm) |
| 3" | 9" (229mm) |

Bending PEX

Uponor PEX bend radius

The minimum bend radius of Uponor AquaPEX pipe is six times the outside diameter. Bend supports are available for $\frac{3}{8}$ ", $\frac{1}{2}$ ", $\frac{3}{4}$ " and 1" piping and may be used to facilitate 90-degree rigid bends. Use large-diameter PVC conduit to facilitate 90-degree bends in larger-diameter Uponor PEX piping.

Table 2: Bending Uponor PEX

| Pipe size | Pipe O.D. | Min. bend radius | 2 x O.D. |
|-----------------|-----------|-----------------------------|----------------------------|
| $\frac{1}{2}$ " | 0.625" | $3\frac{3}{4}$ " (95mm) | $1\frac{1}{4}$ " (32mm) |
| $\frac{3}{4}$ " | 0.875" | $5\frac{1}{4}$ " (133mm) | $1\frac{3}{4}$ " (44mm) |
| 1" | 1.125" | $6\frac{3}{4}$ " (171mm) | $2\frac{1}{4}$ " (57mm) |

To alleviate stress on ProPEX connections and fittings, do not change direction immediately after a ProPEX connection.

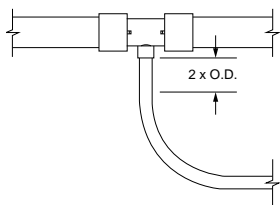

Figure 22: Correct bending



Figure 21: Bend radius

Uponor recommends a minimum of two times the outside diameter (O.D.) of the pipe as the minimum distance before changing direction; however, it is up to the installer to use best judgment. See **Figures 22** and **23** for guidance.

Note: When a proper bend is not possible, use a ProPEX elbow.

Note: Uponor recommends the use of elbows in sizes $1\frac{1}{4}$ " and larger for directional changes unless adequate space is available for a proper bend.

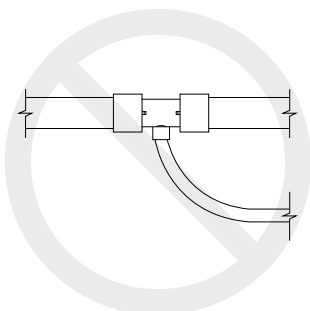

Figure 23: Incorrect bending

Uponor PEX ultraviolet (UV) resistance ratings

Table 3: Uponor PEX UV resistance ratings

| Product | Marking | UV resistance |
|----------------------|---------|---------------|
| Uponor AquaPEX white | 5106 | 1 month |
| Uponor AquaPEX blue | 5306 | 6 months |
| Uponor AquaPEX red | 5306 | 6 months |
| Wirsbo hePEX™ | 5106 | 1 month |

Note: Uponor AquaPEX Reclaimed Water pipe has not been tested for UV resistance.

UV from light fixtures

Do not install PEX within 5 ft. (1.5m) of direct view from fluorescent and LED lights unless protected with a UV-blocking material (i.e., approved insulation or plastic wrap/sleeve).

Storing and handling guidelines

- Uponor PEX may be connected directly to electric water heaters, as well as power-vented gas water heaters where allowed by local code.
- Protect Uponor PEX with grommets when passing through metal framing members.
- Do not store Uponor PEX piping outdoors. Keep the piping in the original packaging until the time of installation.
- Do not use Uponor PEX piping where temperatures and pressures exceed limits.
- Do not weld, glue or use adhesives or adhesive tape with Uponor PEX piping.
- Do not apply open flame to Uponor PEX piping.
- Do not install Uponor PEX within 6" (15.2cm) of a vent pipe for direct or gravity-vented appliances.*

*Maintain a minimum 1" (25mm) distance from double-wall B vents or zero-clearance plastic vents.

- Do not install Uponor PEX piping within 12" (0.3m) of any recessed light fixture unless the piping is protected with suitable insulation or the light is Insulation Contact (I.C.) rated. Note that PEX must maintain a minimum 2" (51mm) clearance unless insulated with a suitable insulation.
- Do not solder, braze, weld or fusion-weld within 18" (45.7cm) of any Uponor PEX piping in the same water line. Make any heat-related connections prior to making the ProPEX connection.
- Use ProPEX lead-free (LF) brass copper press adapters for a flameless transition.
- Do not spray on or allow organic chemicals, strong acids or strong bases to come into contact with Uponor PEX piping.
- Only use closed-cell spray foams approved for use with PEX pipe.
- Avoid spray foam contact with Uponor engineered polymer (EP) fittings.
- Do not use petroleum or solvent-based paints, greases or sealants on Uponor PEX piping. For chemical compatibility questions, contact Uponor Technical Services at 888.594.7726 (U.S.) or 888.994.7726 (Canada).
- Do not install Uponor PEX piping between the tub/shower valve and the tub spout.
- Do not use Uponor PEX piping for an electrical ground.
- Do not press Uponor ProPEX brass sweat fittings. For copper press systems, use Uponor ProPEX LF brass copper press adapters.

Note: When transitioning from Uponor PEX to other piping materials, follow the appropriate installation instructions for that product.

Supporting Uponor PEX pipe

General notes

- Use copper tube size (CTS) clamps/supports
- Use clamps/supports designed for plastic pipe
- Follow local code requirements

Coiled piping

Refer to **Table 4** when supporting coiled PEX piping. Utilize the pipes natural flexibility to reduce fittings and connections for fixture runouts.



Figure 24: Supporting small-diameter coiled PEX

Table 4: Support requirements for coiled PEX pipe

| Nominal pipe size | Maximum horizontal support spacing for coiled PEX pipe | |
|-----------------------------|---|---|
| | International codes (IPC/IMC) and Uniform Codes (UPC/UMC) | National Plumbing Code of Canada (NPCC) |
| 1" and smaller | 2.67 ft. (32") | 0.8m |
| 1¼" and larger ¹ | 4 ft. (48") | 0.8m |

¹ Uponor recommends the use of PEX-a Pipe Support for systems with a Delta T (ΔT) greater than 40°F (22.2°C).

Supporting Uponor multiport tees

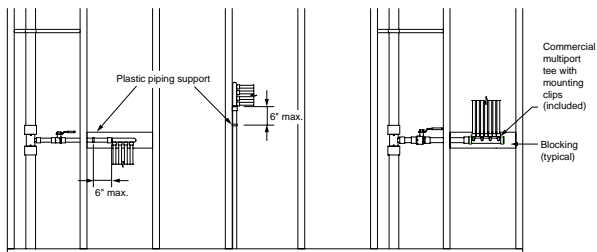

Figure 25: In-wall supports for multiport tees

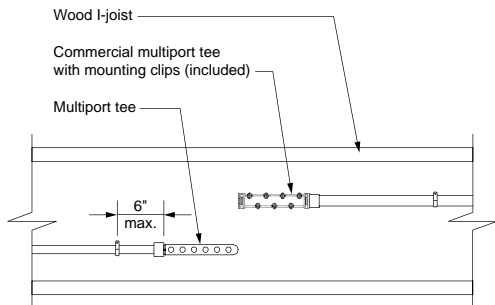

Figure 26: Supporting multiport tees on wood I-joists

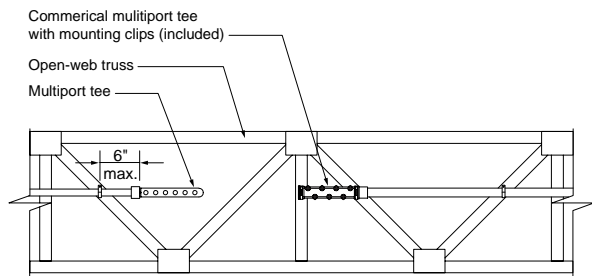

Figure 27: Supporting multiport tees on open-web wood trusses

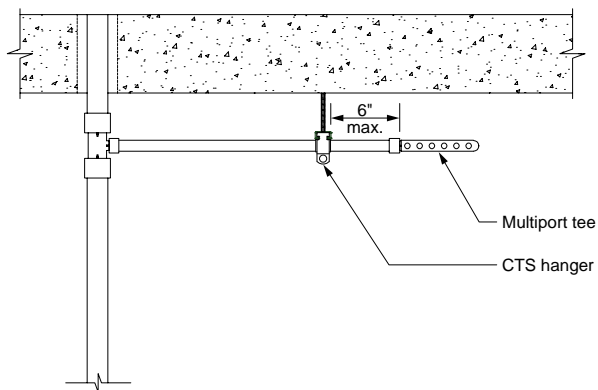

Figure 28: Supporting multiport tees in suspended applications

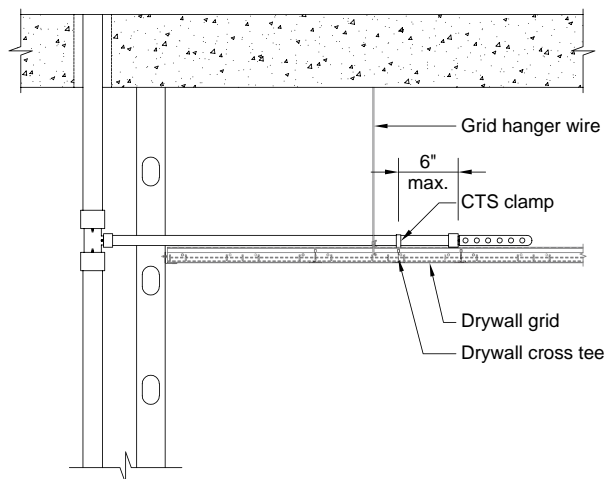

Figure 29: Supporting multiport tees on drywall grid

Strapping

Support Uponor PEX pipe by approved materials/methods only, including:

- Tube talons
- Clamps and hangers (i.e., loop or clevis hangers)
- Stand-off brackets

Isolate piping from other mechanical, electrical and plumbing (MEP) systems by means of insulation or stand-off brackets. Uponor does not recommend strapping PEX pipe directly to waste and vent piping. Always follow local code.



Figure 30: Proper bundling of Uponor PEX

Bundling

Parallel runs of Uponor PEX may be bundled together, when approved by local code, given the following:

- Bundle hot and cold water pipes separately at least 6" apart (15.2cm), unless piping is insulated.
- Support the bundle at the required on-center distance.
- Use cable ties to group a bundle.*

*Cable ties are not approved for supporting pipe.

Main/corridor straight-length piping

Per ICC-ES PMG 1006, using Uponor PEX-a Pipe Support allows extended support spacing up to 8 ft. (2.4m). Refer to **Table 5**.

Note: To minimize sagging and expansion/contraction, Uponor recommends using PEX-a Pipe Support for all main/corridor piping systems with ΔT s greater than 40°F (22.2°C).

Table 5: Horizontal support requirements with PEX-a Pipe Support

| System type | Max. support spacing with PEX-a Pipe Support | Fixed points |
|---|--|--------------------|
| ΔT less than or equal to 40°F (22.2°C) (e.g., domestic cold water, chilled water) ¹ | 8 ft. (2.4m) | Not required |
| ΔT greater than 40°F (22.2°C) (e.g., domestic hot water, domestic hot water recirculation, heating hot water) ¹ | 8 ft. (2.4m) with clamps every 32 ft. (9.7m) max. ² | See Table 6 |

¹These system examples are merely a suggestion of system types. The deciding factor is the temperature differential (Delta T) at the time of system start up.

²Fittings that are 1½" and smaller require support within 12" (0.3m) to prevent sagging. It is acceptable practice to support the fittings from their respective branch pipes.

Definitions

Use the below definitions with **Tables 5 and 6**.

Delta T (ΔT) – Difference between ambient air temperature and average system operating temperature.

Support – Loop, clevis, strut or similar that provide support for the piping system.

Clamps – Strut clamps or split-ring clamps that both support the piping system and limit its movement.

Fixed point – A support with clamps that is braced to the structure to prevent its movement due to expansion and/or contraction of the piping system. See **Figure 31**.



Figure 31: Supporting PEX with PEX-a Pipe Support

Expansion and contraction

To help minimize expansion and contraction in long, continuous piping runs with ΔT s greater than 40°F (22.2°C), use fixed points in conjunction with PEX-a Pipe Support and clamps. Refer to **Table 6** for requirements.

Table 6: Fixed-point requirements

| Length of straight-piping run | # of fixed points* | Fixed-point spacing |
|-------------------------------|--------------------|---------------------------------------|
| 0 – 63 ft. (0 – 19.2m) | 0 | N/A |
| 64 – 128 ft. (19.5 – 39m) | 1 | Closest support with clamps to center |
| 129 – 192 ft. (39.3 – 58.5m) | 2 | Min. 64 ft. apart (19.5m) |
| 193 – 256 ft. (58.8 – 78m) | 3 | |
| 257 – 320 ft. (78.3 – 97.5m) | 4 | |

*Pipes 1" and smaller do not require fixed points.

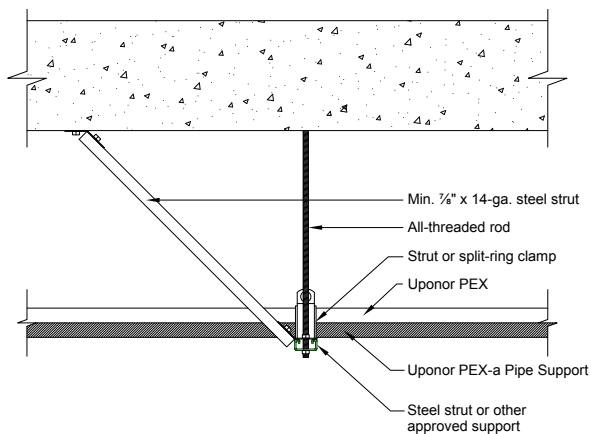

Figure 32: Fixed point

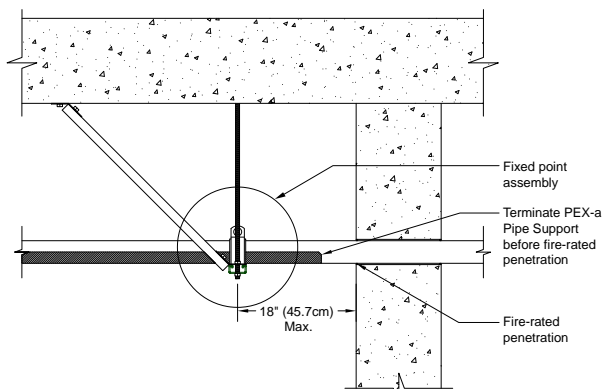
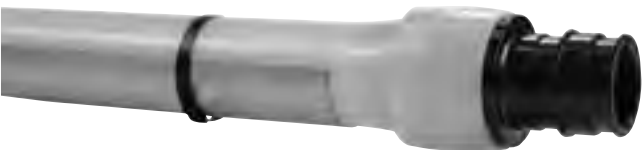

Figure 33: Fixed point near fire-penetration

Note: For 1¼" and larger PEX pipes with a ΔT greater than 40°F (22.2°C), install a fixed point within 18" (45.7cm) of a horizontal fire penetration.



Installing Uponor PEX-a Pipe Support

- Use full lengths and minimize cutting when possible.
- Deburr sharp edges if cutting is required.
- Maintain minimum distance to fittings according to **Table 7**.
- Secure included straps according to **Figures 35-38**.

Table 7: Minimum distance to fittings for PEX-a Pipe Support

| Nominal pipe size | Distance to fitting "A" |
|-------------------|-------------------------|
| 1/2" | 1 1/4" (32mm) |
| 3/4" | 1 3/4" (44mm) |
| 1" | 2 1/4" (57mm) |
| 1 1/4" | 2 3/4" (70mm) |
| 1 1/2" | 3" (76mm) |
| 2" | 4" (102mm) |
| 2 1/2" | 5" (127mm) |
| 3" | 6" (152mm) |

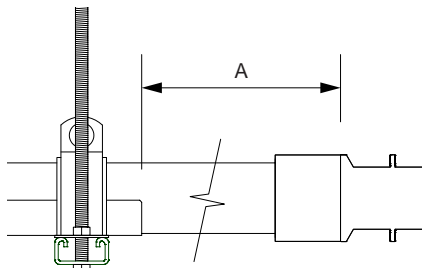

Figure 34: Minimum distance to fitting

Strapping PEX-a Pipe Support

Use the included stainless-steel straps to secure PEX-a Pipe Support to the PEX pipe. If the straps are misplaced, use a stainless-steel strap with a minimum 300-lb. rating that is also rated for the application (e.g., temperature, UV).

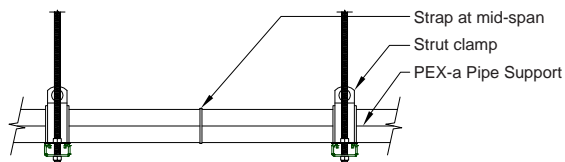

Figure 35: Strapping for systems using strut-type clamps or equivalent

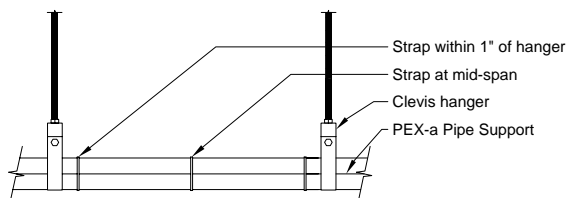

Figure 36: Strapping for systems using clevis or loop-type hangers or equivalent

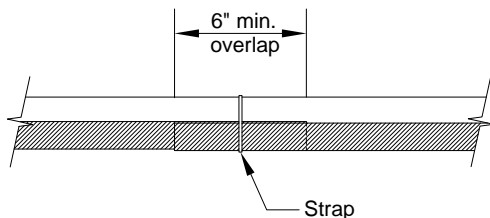

Figure 37: Strapping for overlaps

Fitting bridges

Use a fitting bridge to provide additional support to ½" to 1½" mid-span fittings. To create a fitting bridge, cut an oversized piece of PEX-a Pipe Support to the length shown in **Table 8** and strap using the included stainless-steel straps and

Table 8: Fitting bridge size and length

| Nominal pipe/ fitting size | PEX-a Pipe Support size | PEX-a Pipe Support bridge minimum length |
|-------------------------------|----------------------------|---|
| ½" | 1" | 5½" (13.9cm) |
| ¾" | 1¼" | 7½" (19cm) |
| 1" | 1½" | 10½" (26.6cm) |
| 1¼" | 2" | 12" (30.4cm) |
| 1½" | 2" | 13½" (34.2cm) |

Note: Fitting bridges are not required on 2" and larger pipe sizes.

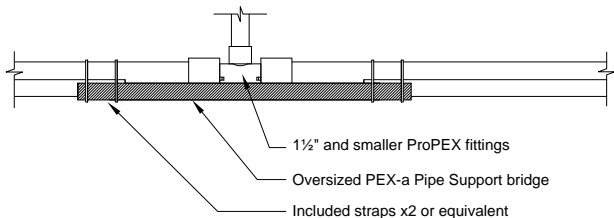

Figure 38: Fitting bridge

ASTM E84 requirements for PEX-a Pipe Support

Uponor PEX-a Pipe Support is tested and approved for use in ASTM E84 applications. To meet the requirements, install PEX-a Pipe Support per the following requirements:

- Cover pipe or fittings without PEX-a Pipe Support with a minimum ½" (13mm) thick rated insulation.
- There is no minimum segment length of PEX-a Pipe Support.

When installed per the above requirements, there are no spacing limitations between parallel piping runs.

Note: The above requirements also apply to PEX-a Pipe Support installed in a vertical position for ASTM E84 applications.

Note: Exposed sections of ½" and ¾" Uponor PEX pipe can be installed un-insulated if the pipe runs are separated by a minimum of 18" (45.7cm).

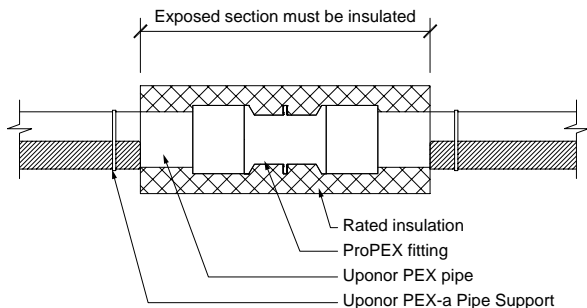

Figure 39: PEX-a Pipe Support installations in ASTM E84 applications

Supporting large-diameter valves

Table 9: Support requirements for large-diameter valves

| Nominal pipe size | Valve-type | Maximum support distance "A" |
|-------------------|------------|------------------------------|
| 1¼" - 2" | Ball | 18" (45.7cm) |
| 2½" - 3" | Butterfly | 7" (17.7cm) |

Note: For ball valves larger than 2", support within 7" (17.7cm).

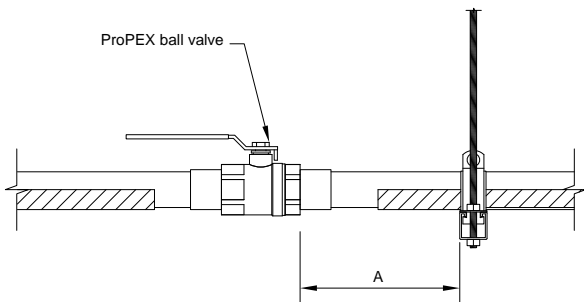

Figure 40: Supporting 1¼" to 2" ball valves

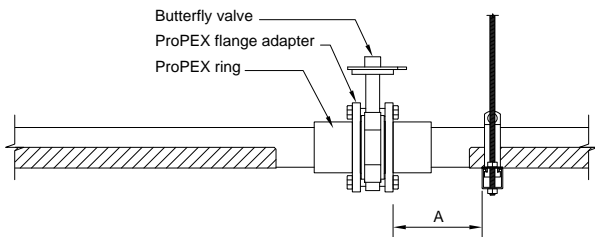

Figure 41: Supporting 2½" to 3" butterfly valves

Vertical support requirements

Vertical runs of pipe fall into two categories: in-wall and risers.

In-wall piping is typically smaller in diameter (<1"), and does not pass through multiple floors like a riser. It is most often the dedicated supply piping to the fixture.

Riser piping is typically larger in diameter (>1") and passes through multiple floors, often requiring fire-penetration sealants.

Note: The two categories above are not mutually exclusive. Use best judgement when determining which supports are necessary.

Table 10: Vertical support requirements for PEX pipe

| | | Nominal pipe size | All codes |
|---------|----------------------------------|-------------------|---|
| In wall | | All pipe sizes | 5 ft. (1.5m) |
| Risers | Domestic cold water | All pipe sizes | Clamp at the base of each floor; clamp at top of every fourth floor; support every 5 ft. (1.5m) |
| | Domestic hot water | All pipe sizes | Clamp at base of each floor; clamp at top of every-other floor; support every 5 ft. (1.5m) |
| | Heating hot water; chilled water | All pipe sizes | Clamp at base of each floor; clamp at top of every floor; support every 5 ft. (1.5m) |

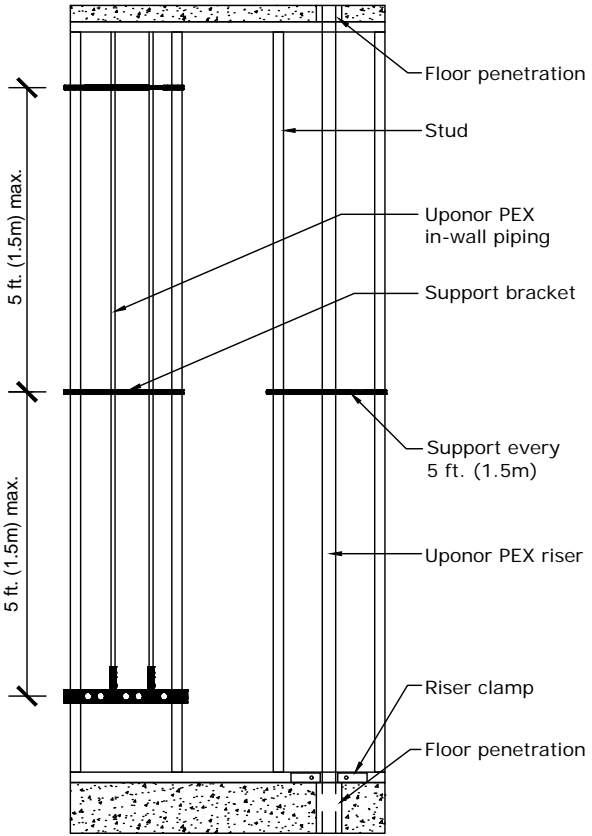

Figure 42: In-wall versus riser piping

Riser clamps

To prevent damage to ProPEX fittings, Uponor recommends the following minimum distances between riser clamps and ProPEX fittings.

Table 11: Distance to clamps

| Nominal pipe size | 2 x O.D. |
|-------------------|-------------|
| ½" | 1¼" (32mm) |
| ⅝" | 1½" (38mm) |
| ¾" | 1¾" (44mm) |
| 1" | 2¼" (57mm) |
| 1¼" | 2¾" (70mm) |
| 1½" | 3¼" (83mm) |
| 2" | 4¼" (108mm) |
| 2½" | 4¾" (133mm) |
| 3" | 6¼" (159mm) |
| 3½" | 7¼" (184mm) |
| 4" | 8¼" (210mm) |

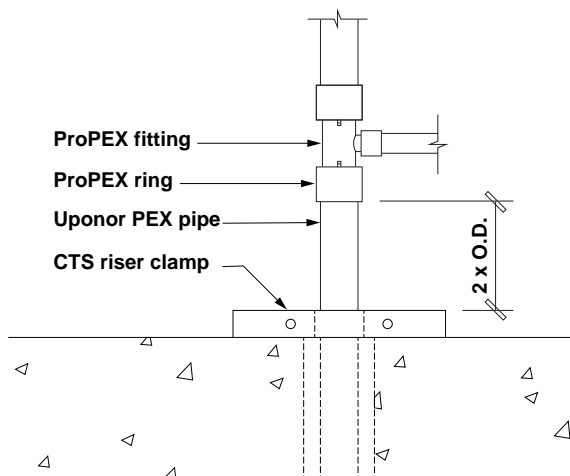

Figure 43: Riser clamp detail

Risers

Vertical piping runs must comply with support spacing as defined by code. Best practice is to use the floor/ceiling assembly as a fixed point for controlling expansion and contraction by means of riser clamps.

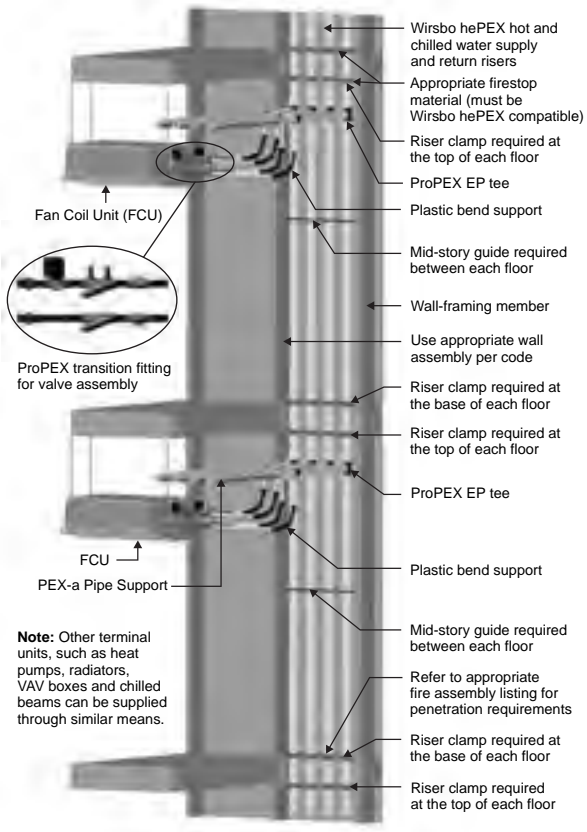

Figure 44: Hydronic piping riser detail

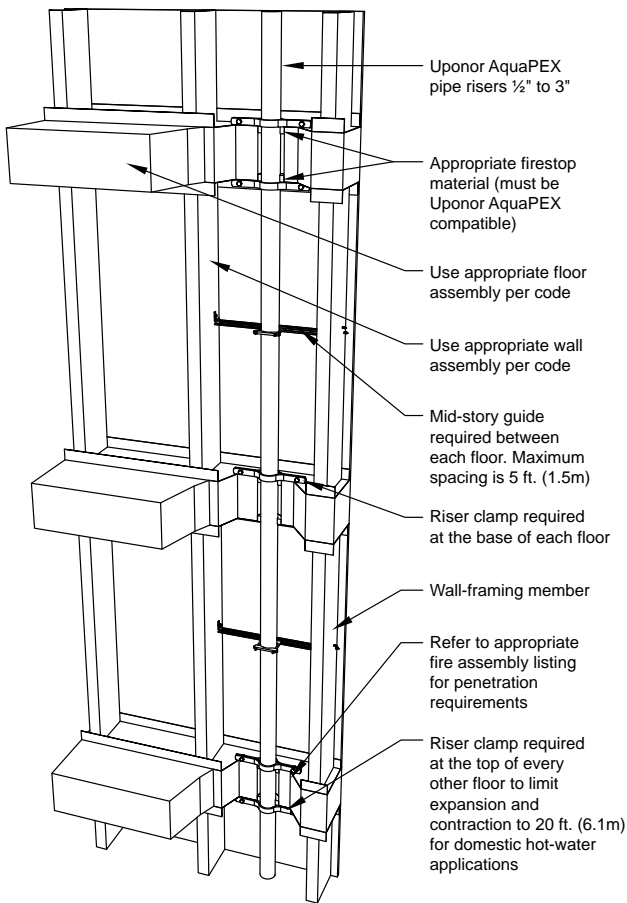

Figure 45: Domestic hot-water riser detail

Fire-resistant construction

The following requirements are for Uponor products installed in return-air plenum spaces.



United States — ASTM E84

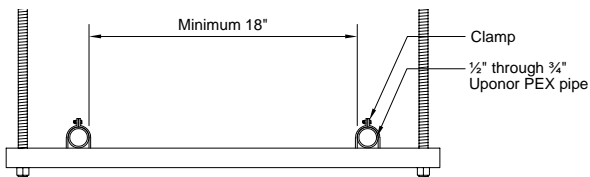

Figure 46: QAI P321-1

Guidelines: 1/2" through 3/4" (uninsulated)

Limitations: Adjacent runs shall be located at least 18" (45.7cm) apart.

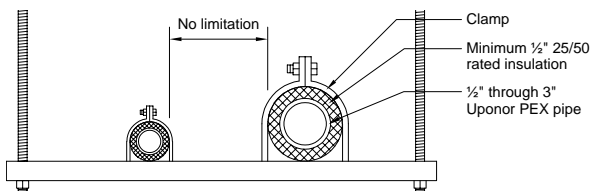

Figure 47: QAI P321-1

Guidelines: 1/2" through 3" (insulated)

Limitations: 1/2" minimum thickness insulation as specified in **Table 12**.

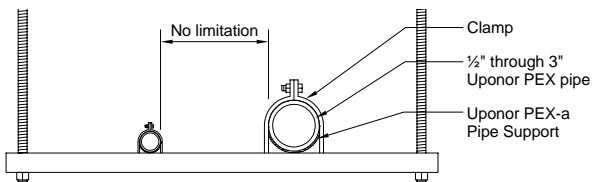

Figure 48: QAI P321-2

Guidelines: 1/2" through 3" (PEX-a Pipe Support)

Limitations: Pipe or fitting sections without PEX-a Pipe Support must be covered with a rated insulation per **Table 12**. There is no minimum length of PEX-a Pipe Support segments.



Canada — CAN/ULC-S102.2

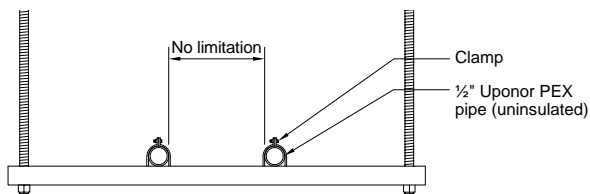

Figure 49: QAI P321-1

Guidelines: 1/2" (uninsulated)

Limitations: No spacing limitations.

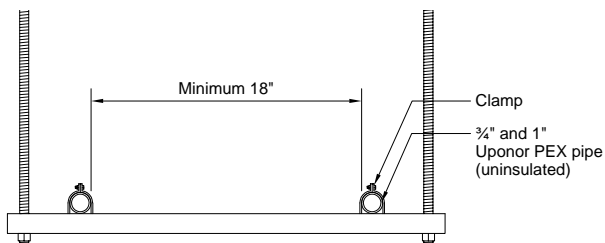

Figure 50: QAI P321-1

Guidelines: 3/4" and 1" (uninsulated)

Limitations: Adjacent pipe runs shall be located at least 18" (45.7cm) apart.

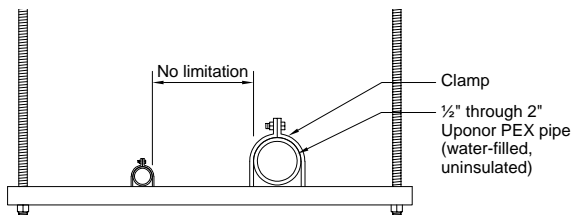

Figure 51: QAI P321-3

Guidelines: 1/2" through 2" (water-filled)

Limitations: No spacing limitations.



Canada — CAN/ULC-S102.2

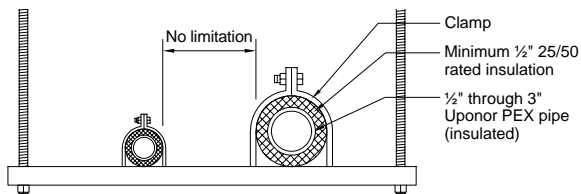

Figure 52: QAI P321-1

Guidelines: 1/2" through 3" (insulated)

Limitations: 1/2" minimum thickness insulation as specified in **Table 12**.

Table 12: Specifications for pipe insulations in ASTM E84 and CAN/ULC-S102.2 applications

| Specifications for pipe insulations in ASTM E84 and CAN/ULC-S102.2 applications | | | |
|--|--------------------------------|--------------------|--------------------------|
| Products (minimum thickness) | ASTM E84 and CAN/ULC-S102.2 | | Density of insulation |
| | Flame spread | Smoke developed | |
| 1/2" Manson Alley-K Fiberglass Pipe Insulation | 25 or less | 50 or less | 4.0 pcf |
| 1/2" Armaflex Composite Pipe Insulation | 25 or less | 50 or less | 3.0 pcf |
| 1/2" Johns Manville Micro-Lok Fiberglass Pipe Insulation | 25 or less | 50 or less | 3.3 pcf |
| 1/2" Johns Manville Micro-Lok HP | 25 or less | 50 or less | 3.5 pcf |
| 1/2" Owens Corning VaporWick Pipe Insulation | 25 or less | 50 or less | 4.0 pcf |
| 1/2" Owens Corning Fiberglass Pipe Insulation | 25 or less | 50 or less | 3.5 pcf |
| 1/2" Knauf Earthwool Redi-Klad Pipe Insulation | 25 or less | 50 or less | 3.8 pcf |
| 1/2" GLT Pipe and Tank Insulation | 25 or less | 50 or less | 4.5 pcf |
| 1/2" Nomalock Pipe Insulation* | 25 or less | 50 or less | 4.0 pcf |

*Check the rated grade of Nomalock insulations for plenum use.

ASTM E814 and CAN/ULC S115 listings

Table 13: Fire assemblies per manufacturer

| Assembly types | | Manufacturer | | | |
|---------------------------------|--------|--------------|---------------|----------|---------------|
| | | 3M™ | | Hilti® | |
| | | Wall | Floor/ceiling | Wall | Floor/ceiling |
| Wood-stud/steel-stud assemblies | 1-hour | PHV-120-04 | F-C-2039 | W-L-2186 | F-C-2081 |
| | | PHV-120-11 | F-C-2240 | W-L-2235 | F-C-2230 |
| | | W-L-2091 | F-C-2343 | W-L-2466 | F-C-2310 |
| | | W-L-2146 | F-C-2344 | W-L-2474 | F-C-2334 |
| | | W-L-2173 | F-C-2391 | W-L-2480 | F-C-8038 |
| | | W-L-2448 | F-E-2002 | W-L-2537 | F-C-8044 |
| | | W-L-2483 | F-E-2012 | W-L-2467 | |
| | | W-L-2543 | F-E-2040 | W-L-5224 | |
| | | W-L-2547 | PHV-120-04 | | |
| | | W-L-2299 | PHV-120-11 | | |
| | | PV-60-02 | | | |
| | | | | | |
| | | | | | |

Note: This table is not meant to address every compatible fire assembly or firestop manufacturer approved and current for the specific application. Please refer to the respective manufacturer's website for more information.

■ = ASTM E814 and CAN/ULC S115 ■ = ASTM E814 only

| Manufacturer | | | |
|--------------|---------------|----------|---------------|
| RectorSeal® | | STI | |
| Wall | Floor/ceiling | Wall | Floor/ceiling |
| W-L-2342 | F-C-2298 | F-C-2319 | F-C-2032 |
| W-L-2262 | F-C-8015 | W-L-2100 | F-C-2252 |
| W-L-2373 | F-C-2329 | W-L-2144 | F-C-2319 |
| W-L-2430 | F-C-2212 | W-L-2241 | F-E-2003 |
| W-L-2526 | F-E-2007 | W-L-2242 | F-C-8021 |
| W-L-2121 | F-C-2221 | W-L-2423 | F-C-8029 |
| W-L-2209 | F-C-2385 | W-L-2508 | F-E-8003 |
| W-L-2528 | | W-L-2548 | F-C-8045 |
| W-L-2402 | | W-L-2549 | F-E-8010 |
| W-L-2638 | | W-L-7193 | |
| W-L-2639 | | F-C-8021 | |
| W-L-2007 | | F-C-8029 | |
| W-L-2170 | | W-L-5290 | |
| W-L-2287 | | W-L-2631 | |
| W-L-2457 | | | |
| W-L-2524 | | | |
| W-L-2594 | | | |
| W-L-2595 | | | |

It is the end user's responsibility to ensure the fire assembly documentation being used is up to date. Visit the manufacturer's website for detailed listing information.

■ = ASTM E814 and CAN/ULC S115 ■ = ASTM E814 only

ASTM E814 and CAN/ULC S115 listings

Table 14: Fire assemblies per manufacturer

| Assembly types | | Manufacturer | | | |
|---------------------------------|--------|--------------|---------------|----------|---------------|
| | | 3M™ | | Hilti® | |
| | | Wall | Floor/ceiling | Wall | Floor/ceiling |
| Wood-stud/steel-stud assemblies | 2-hour | PHV-120-04 | PHV-120-04 | W-L-2186 | F-C-2081 |
| | | PHV-120-11 | PHV-120-11 | W-L-2235 | F-C-2310 |
| | | W-L-2090 | | W-L-2466 | |
| | | W-L-2091 | | W-L-2474 | |
| | | W-L-2146 | | W-L-2480 | |
| | | W-L-2448 | | W-L-2537 | |
| | | W-L-2483 | | W-L-2467 | |
| | | W-L-2543 | | W-L-5224 | |
| | | W-L-2547 | | | |
| | | W-L-2299 | | | |
| | | | | | |
| | | | | | |
| | | | | | |

Note: This table is not meant to address every compatible fire assembly or firestop manufacturer approved and current for the specific application. Please refer to the respective manufacturer's website for more information.

■ = ASTM E814 and CAN/ULC S115 ■ = ASTM E814 only

| RectorSeal® | | STI | |
|-------------|---------------|----------|---------------|
| Wall | Floor/ceiling | Wall | Floor/ceiling |
| W-L-2342 | F-C-2221 | W-L-2100 | |
| W-L-2262 | F-C-2385 | W-L-2144 | |
| W-L-2373 | | W-L-2241 | |
| W-L-2430 | | W-L-2242 | |
| W-L-2526 | | W-L-2423 | |
| W-L-2121 | | W-L-2508 | |
| W-L-2209 | | W-L-2548 | |
| W-L-2528 | | W-L-2549 | |
| W-L-2402 | | W-L-7193 | |
| W-L-2638 | | W-L-5290 | |
| W-L-2639 | | W-L-2631 | |
| W-L-2170 | | | |
| W-L-2287 | | | |
| W-L-2457 | | | |
| W-L-2524 | | | |
| W-L-2594 | | | |
| W-L-2595 | | | |

It is the end user's responsibility to ensure the fire assembly documentation being used is the most current version available on the manufacturer's website for detailed listing information.

■ = ASTM E814 and CAN/ULC S115 ■ = ASTM E814 only

ASTM E814 and CAN/ULC S115 listings

Table 15: Fire assemblies per manufacturer

| Assembly types | | Manufacturer | | | |
|---------------------|--------|--------------|---------------|-----------|---------------|
| | | 3M™ | | Hilti® | |
| | | Wall | Floor/ceiling | Wall | Floor/ceiling |
| Concrete assemblies | 2-hour | C-AJ-2510 | C-AJ-2510 | C-AJ-2170 | C-AJ-2170 |
| | | C-AJ-2536 | C-AJ-2536 | C-AJ-2407 | C-AJ-2407 |
| | | PHV-120-04 | F-A-2115 | C-AJ-2647 | C-AJ-2647 |
| | | PHV-120-11 | PH-120-10 | W-J-2207 | C-AJ-2674 |
| | | C-AJ-2213 | PHV-120-04 | W-J-2229 | F-B-2040 |
| | | C-AJ-2378 | PHV-120-11 | W-J-2206 | F-B-2041 |
| | | W-J-2231 | C-AJ-2076 | W-J-5122 | F-A-2142 |
| | | W-J-2110 | C-AJ-2213 | | W-J-2071 |
| | | C-AJ-2213 | C-AJ-2378 | | |
| | | C-AJ-2378 | C-AJ-2213 | | |
| | | C-AJ-2738 | C-AJ-2378 | | |
| | | PHV-120-12 | C-AJ-2738 | | |
| | | C-AJ-2698 | PHV-120-12 | | |
| | | | C-AJ-2698 | | |
| | | | | | |
| | | | | | |
| | | | | | |
| | | | | | |
| | | | | | |
| | | | | | |
| | 3-hour | | | C-BJ-2028 | C-BJ-2028 |
| | | | | C-BJ-2040 | C-BJ-2040 |
| | | | | C-BJ-2041 | C-BJ-2041 |

Note: This table is not meant to address every compatible fire assembly or firestop manufacturer approved and current for the specific application. Please refer to the respective manufacturer's website for more information.

■ = ASTM E814 and CAN/ULC S115 ■ = ASTM E814 only

| RectorSeal® | | STI | | HOLDRITE |
|-------------|---------------|-----------|---------------|---------------|
| Wall | Floor/ceiling | Wall | Floor/ceiling | Floor/ceiling |
| W-J-2162 | C-AJ-2628 | W-J-2021 | C-AJ-2031 | F-A-2188 |
| W-J-2122 | F-A-2171 | W-J-2043 | C-AJ-2140 | F-A-2221 |
| W-J-2180 | C-AJ-2701 | W-J-2076 | C-AJ-2291 | F-B-2042 |
| W-J-2025 | C-AJ-2176 | W-J-2077 | F-A-2186 | F-A-2269 |
| C-AJ-2628 | F-A-2235 | W-J-2232 | F-A-2224 | F-A-2222 |
| C-AJ-2679 | F-A-2237 | W-J-2233 | F-A-2225 | F-A-2037 |
| C-AJ-2701 | C-AJ-2494 | W-J-5148 | C-AJ-2586 | |
| W-J-2295 | C-AJ-2679 | C-AJ-2586 | C-AJ-5345 | |
| W-J-2296 | C-AJ-2702 | C-AJ-5345 | C-BJ-2046 | |
| C-AJ-2702 | | C-BJ-2046 | | |
| C-AJ-2176 | | W-J-2291 | | |
| C-AJ-2494 | | | | |
| W-J-2035 | | | | |
| W-J-2051 | | | | |
| W-J-2142 | | | | |
| W-J-2197 | | | | |
| W-J-2220 | | | | |
| W-J-2222 | | | | |
| W-J-2224 | | | | |
| W-J-2266 | | | | |
| C-AJ-2119 | C-AJ-2119 | C-AJ-2671 | C-AJ-2671 | F-A-2176 |
| C-AJ-2194 | C-AJ-2194 | C-AJ-5344 | C-AJ-5344 | F-A-2221 |
| C-AJ-2622 | C-AJ-2622 | C-AJ-5346 | C-AJ-5346 | F-B-2042 |
| | | | C-AJ-2578 | F-A-2269 |
| | | | F-A-2203 | F-A-8034 |
| | | | F-A-2204 | F-A-2222 |

It is the end user's responsibility to ensure the fire assembly documentation being used is the most current version available on the website for detailed listing information.

■ = ASTM E814 and CAN/ULC S115 □ = ASTM E814 only

Below-grade installation

Uponor PEX piping and ProPEX fittings (EP and LF brass) are all approved for burial directly in soil. Refer to **Figures 53** and **54** for proper trench preparation. Always follow local code when burying Uponor PEX pipe as some jurisdictions require additional sleeving and protection.

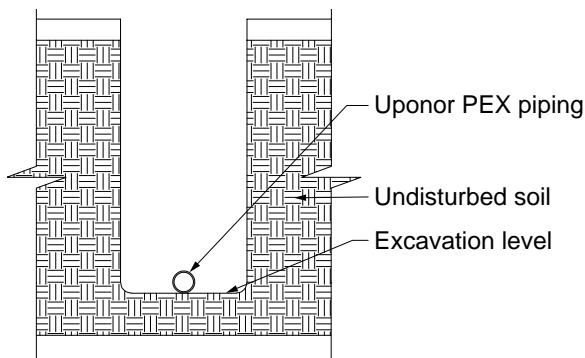

Figure 53: Good soil conditions

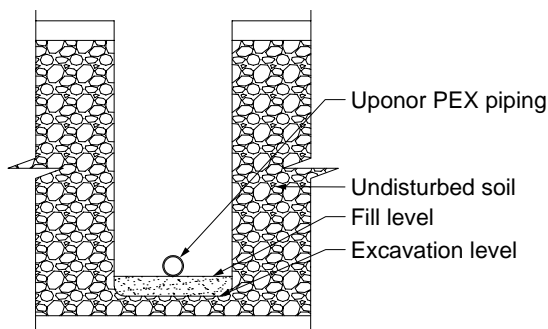

Figure 54: Poor soil conditions

Horizontal directional drilling (HDD)

Uponor PEX HDD requirements:

- Up to 600 ft. (182m) in length
- Depths up to 15 ft. (4.5m)

PEX pipe must:

- Be the follow pipe
- Not contact any sharp objects
- Be pressure tested after installation

Table 16: Safe pull force

| SDR9 PEX-a 12-hour pull | | |
|-------------------------|--------------------------------------|--|
| Nominal pipe size | Tensile yield design (safety) factor | Allowable tensile load at 73°F (22.8°C) lbs. (N) |
| ½" | 0.4 | 128 (569) |
| ¾" | 0.4 | 248 (1,103) |
| 1" | 0.4 | 411 (1,828) |
| 1¼" | 0.4 | 615 (2,735) |
| 1½" | 0.4 | 859 (3,821) |
| 2" | 0.4 | 1,465 (6,516) |
| 2½" | 0.4 | 2,239 (9,960) |
| 3" | 0.4 | 3,169 (14,096) |

In-slab installation

Uponor PEX piping and ProPEX EP and brass fittings are approved for embedment in concrete. Always follow local code when embedding Uponor PEX pipe as some jurisdictions require additional sleeving and protection. Uponor recommends using Pre-sleeved Uponor AquaPEX pipe for embedment in concrete when additional protection is required.

Note: Cover brass fittings with a protective material, such as 6-mil poly wrap, and secure with cable ties.



Figure 55: In-slab installation

Pressure testing

Residential applications

1. Pressurize system to 25 psi (1.7 bar) above working pressure or 100 psi (6.9 bar).
2. Test in accordance with local code.

Commercial applications

1. Visually confirm all connections are properly made per Uponor installation guidelines.
2. Ensure that all components, fixtures and equipment not rated for the test pressure are isolated from the test system.
3. Ensure that all other thermoplastic piping materials are isolated from the test system.
4. Fill the system with potable water, air or a mixture of both.
5. Condition the system to 1.5 times the required test pressure for 30 minutes. This will require constant pumping or cycling the valve and compressor to maintain a pressure of 1.5 times the test pressure. If cycling the valve and compressor, apply additional pressure once the psi has dropped 10 psi (0.7 bar).
6. After conditioning the system for 30 minutes, quickly relieve excess pressure by opening the valve. Close the valve when the system has reached the desired test pressure.

Note: Uponor recommends a test pressure of 80 psi (5.5 bar) (unless local code dictates higher pressures).

7. Once the valve is closed, confirm a slight rise in pressure 3 to 6 psi (0.2 to 0.4 bar). This increase will occur as the pipe's I.D. is shrinking from its conditioned state to equalize at the lower pressure.
8. Visually check for leakage and monitor the pressure for the duration specified by local code. (A typical pressure test can range from 2 to 24 hours).
9. If there is no reduction in pressure, the system is regarded as leak tight.

Note: Slight fluctuations of pressure are normal due to ambient temperature changes, especially during long durations (e.g., 24 hours).

10. Flush the system as required by code.

Note: If using water to pressure test the system, purge all water from the system prior to the ambient air temperatures falling to 32°F (0°C). Failing to remove the water from the system can result in damage to the piping and associated equipment.

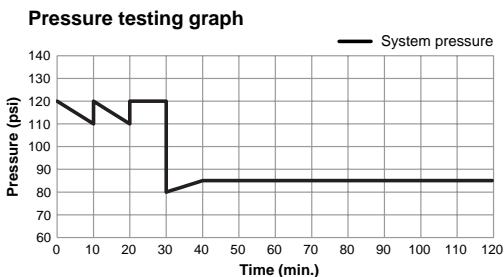

Figure 56: Pressure testing graph

Water system disinfection

Uponor recommends flushing an AquaPEX plumbing system with clean, potable water. When system disinfection is required, Uponor AquaPEX piping should be disinfected in accordance with AWWA C651, Standard for Disinfecting Water Mains, or local codes.

Note: To prevent reduced service life of system components, disinfection solutions should not remain in the system longer than 24 hours. Flush the system with potable water after disinfection.

Use a chlorine solution of 50 parts per million (ppm) for 24 hours or 200 ppm for three hours for disinfection.

Appendix A: Dimensions and physical characteristics of Uponor PEX pipe

Table A-1: Dimensions and physical characteristics of SDR9 Uponor PEX pipe

| Dimensions and physical characteristics of SDR9 Uponor PEX pipe | | | | | | |
|---|----------------|----------------|-----------------------------------|-------------------------------|--|--|
| Nominal pipe size | Pipe O.D. (in) | Pipe I.D. (in) | Weight of pipe only lbs/ft (kg/m) | Contents of pipe gal/ft (l/m) | Weight of pipe and water lbs/ft (kg/m) | |
| 1/4" | 0.375 | 0.241 | 0.04 (0.018) | 0.0024 (0.009) | 0.06 (0.027) | |
| 3/8" | 0.50 | 0.35 | 0.05 (0.022) | 0.005 (0.018) | 0.09 (0.040) | |
| 1/2" | 0.625 | 0.475 | 0.06 (0.027) | 0.0092 (0.034) | 0.14 (0.063) | |
| 5/8" | 0.750 | 0.574 | 0.08 (0.036) | 0.0134 (0.050) | 0.19 (0.086) | |
| 3/4" | 0.875 | 0.671 | 0.1 (0.045) | 0.0184 (0.069) | 0.25 (0.113) | |
| 1" | 1.125 | 0.862 | 0.2 (0.090) | 0.0303 (0.114) | 0.45 (0.204) | |
| 1 1/4" | 1.375 | 1.054 | 0.34 (0.154) | 0.0453 (0.171) | 0.72 (0.326) | |
| 1 1/2" | 1.625 | 1.244 | 0.44 (0.199) | 0.0632 (0.239) | 0.96 (0.435) | |
| 2" | 2.125 | 1.629 | 0.682 (0.309) | 0.1083 (0.409) | 1.58 (0.716) | |
| 2 1/2" | 2.625 | 2.011 | 0.93 (0.421) | 0.1649 (0.624) | 2.3 (1.043) | |
| 3" | 3.125 | 2.4 | 1.28 (0.580) | 0.2351 (0.889) | 3.24 (1.469) | |

Appendix B: Hydrostatic temperature and pressure ratings

Uponor maintains standard-grade ratings for Uponor PEX piping. Uponor PEX carries the following temperature and pressure ratings shown in **Table B-1**.

Note: Uponor EP and LF brass fittings carry the same temperature and pressure ratings as Uponor PEX pipe.

Table B-1: Hydrostatic temperature and pressure ratings for Uponor PEX pipe

| ASTM F876 temperature and pressure ratings for SDR9 PEX | | |
|---|-------------------------------------|-------------------------------|
| Rated temperature | Hydrostatic design stress (HDS) psi | Pressure rating for water psi |
| 73.4°F/23°C | 630 | 160 psi (11 bar) |
| 180°F/82°C | 400 | 100 psi (6.9 bar) |
| 200°F/93°C | 315 | 80 psi (5.5 bar) |

Interpolation method

Pressure ratings at different temperatures are determined by using a linear relationship between the standard-grade ratings. See **Table B-2** for interpolated temperature and pressure ratings.

Excessive temperature and pressure capability

In accordance with ASTM F876 Standard Specification for Crosslinked Polyethylene (PEX) Piping, the excessive temperature and pressure capability of Uponor PEX is 210°F at 150 psi (99°C at 10 bar).

This standard requires that Uponor PEX piping maintain its integrity for a period of 720 hours (30 days) at 210°F (99°C) at 150 psi (10 bar). If installed as directed, Uponor PEX will withstand these conditions.

Note: Excessive temperature and pressure requirements are always subject to approval by local building codes (e.g., temperature and pressure-relief valves).

Table B-2: Interpolated hydrostatic temperature and pressure ratings for Uponor PEX pipe

| Interpolated hydrostatic temperature and pressure ratings | |
|---|-----------------|
| °F/°C | PSI/bar |
| 200.0/93.3 | 80/5.5 |
| 190.0/87.8 | 90/6.2 |
| 180.0/82.2 | 100/6.9 |
| 170.0/76.7 | 106/7.3 |
| 160.0/71.1 | 111/7.7 |
| 150.0/65.6 | 117/8.0 |
| 140.0/60.0 | 123/8.5 |
| 130.0/54.4 | 128/8.8 |
| 120.0/48.9 | 134/9.2 |
| 110.0/43.3 | 139/9.6 |
| 100.0/37.8 | 145/10.0 |
| 90.0/32.2 | 151/10.4 |
| 80.0/26.7 | 156/10.8 |
| 73.4/23.0 | 160/11.0 |
| 60.0/15.6 | 168/11.6 |
| 50.0/10.0 | 173/11.9 |
| 40.0/4.4 | 179/12.3 |

Appendix C: ProPEX fitting dimensions

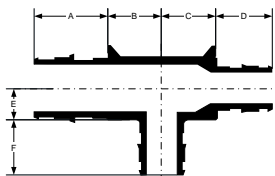

| ProPEX EP reducing tees | | A | B | C | D | E | F |
|-------------------------|----------|---------|-------|-------|-------|-------|--------|
| Description | Part no. | in | in | in | in | in | in |
| | | mm | mm | mm | mm | mm | mm |
| 1/2" PEX x 1/2" | Q4755575 | 3/4 | 11/16 | 11/16 | 3/4 | 1/2 | 15/16 |
| PEX x 3/4" PEX | | 19 | 18 | 18 | 19 | 13 | 24 |
| 3/4" PEX x 1/2" | Q4757555 | 15/16 | 11/16 | 11/16 | 3/4 | 1/2 | 3/4 |
| PEX x 1/2" PEX | | 24 | 18 | 18 | 19 | 13 | 19 |
| 3/4" PEX x 1/2" | Q4757557 | 15/16 | 11/16 | 11/16 | 3/4 | 1/2 | 15/16 |
| PEX x 3/4" PEX | | 24 | 18 | 18 | 19 | 13 | 24 |
| 3/4" PEX x 3/4" | Q4757563 | 15/16 | 11/16 | 11/16 | 15/16 | 9/16 | 7/8 |
| PEX x 5/8" PEX | | 24 | 18 | 18 | 24 | 14 | 22 |
| 3/4" PEX x 3/4" | Q4757550 | 15/16 | 11/16 | 11/16 | 15/16 | 9/16 | 3/4 |
| PEX x 1/2" PEX | | 24 | 18 | 18 | 24 | 14 | 19 |
| 3/4" PEX x 3/4" | Q4757710 | 15/16 | 7/8 | 7/8 | 15/16 | 11/16 | 13/16 |
| PEX x 1" PEX | | 24 | 22 | 22 | 24 | 18 | 30 |
| 1" PEX x 3/4" | Q4751775 | 13/16 | 7/8 | 7/8 | 15/16 | 11/16 | 15/16 |
| PEX x 3/4" PEX | | 30 | 22 | 22 | 24 | 18 | 24 |
| 1" PEX x 3/4" | Q4751751 | 13/16 | 7/8 | 7/8 | 15/16 | 11/16 | 13/16 |
| PEX x 1" PEX | | 30 | 22 | 22 | 24 | 18 | 30 |
| 1" PEX x 1" | Q4751150 | 13/16 | 7/8 | 7/8 | 13/16 | 11/16 | 3/4 |
| PEX x 1/2" PEX | | 30 | 22 | 22 | 30 | 18 | 19 |
| 1" PEX x 1" | Q4751175 | 13/16 | 7/8 | 7/8 | 13/16 | 11/16 | 15/16 |
| PEX x 3/4" PEX | | 30 | 22 | 22 | 30 | 18 | 24 |
| 1 1/4" PEX x 1" | Q4751317 | 13/16 | 15/16 | 15/16 | 17/16 | 15/16 | 15/16 |
| PEX x 3/4" PEX | | 30 | 25 | 25 | 37 | 24 | 24 |
| 1 1/4" PEX x 1" | Q4751311 | 17/16 | 15/16 | 15/16 | 13/16 | 15/16 | 13/16 |
| PEX x 1" PEX | | 37 | 25 | 25 | 30 | 24 | 30 |
| 1 1/4" PEX x 1 1/4" | Q4751350 | 17/16 | 3/4 | 3/4 | 17/16 | 3/4 | 3/4 |
| PEX x 1/2" PEX | | 37 | 19 | 19 | 37 | 19 | 19 |
| 1 1/4" PEX x 1 1/4" | Q4751337 | 17/16 | 7/8 | 7/8 | 17/16 | 3/4 | 15/16 |
| PEX x 3/4" PEX | | 37 | 23 | 23 | 37 | 19 | 24 |
| 1 1/4" PEX x 1 1/4" | Q4751331 | 17/16 | 15/16 | 15/16 | 17/16 | 15/16 | 13/16 |
| PEX x 1" PEX | | 37 | 25 | 25 | 37 | 24 | 30 |
| 1 1/2" PEX x 1" | Q4751517 | 1 11/16 | 13/16 | 13/16 | 13/16 | 1 1/8 | 15/16 |
| PEX x 3/4" PEX | | 43 | 30 | 30 | 30 | 28 | 24 |
| 1 1/2" PEX x 1" | Q4751511 | 1 11/16 | 13/16 | 13/16 | 13/16 | 1 1/8 | 13/16 |
| PEX x 1" PEX | | 43 | 30 | 30 | 30 | 28 | 30 |
| 1 1/2" PEX x 1" | Q4751505 | 1 11/16 | 1 1/4 | 1 1/4 | 13/16 | 15/16 | 1 1/16 |
| PEX x 1 1/2" PEX | | 43 | 32 | 32 | 30 | 24 | 43 |

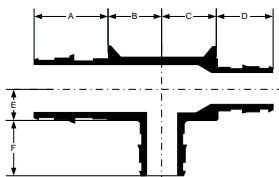

| ProPEX EP reducing tees | | A | B | C | D | E | F |
|------------------------------|----------|---------------------------------|--------------------------------|--------------------------------|---------------------------------|--------------------------------|---------------------------------|
| Description | Part no. | in | in | in | in | in | in |
| | | mm | mm | mm | mm | mm | mm |
| 1½" PEX x ¼" PEX x ¾" PEX | Q4751537 | 1 ¹¹ / ₁₆ | 1 ¹ / ₈ | 1 ¹ / ₈ | 1 ⁷ / ₁₆ | 7 ⁷ / ₈ | 1 ⁵ / ₁₆ |
| | | 43 | 29 | 29 | 37 | 23 | 24 |
| 1½" PEX x ¼" PEX x 1" PEX | Q4751531 | 1 ¹¹ / ₁₆ | 1 ¹ / ₈ | 1 ¹ / ₈ | 1 ⁷ / ₁₆ | 7 ⁷ / ₈ | 1 ³ / ₁₆ |
| | | 43 | 29 | 29 | 37 | 23 | 30 |
| 1½" PEX x ¼" PEX x ¼" PEX | Q4751533 | 1 ¹¹ / ₁₆ | 1 ¹ / ₈ | 1 ¹ / ₈ | 1 ⁷ / ₁₆ | 7 ⁷ / ₈ | 1 ⁷ / ₁₆ |
| | | 43 | 29 | 29 | 37 | 23 | 37 |
| 1½" PEX x ½" PEX x ½" PEX | Q4751550 | 1 ¹¹ / ₁₆ | ¾ | ¾ | 1 ¹¹ / ₁₆ | 1 ⁹ / ₁₆ | ¾ |
| | | 43 | 19 | 19 | 43 | 21 | 19 |
| 1½" PEX x ½" PEX x ¾" PEX | Q4751557 | 1 ¹¹ / ₁₆ | 1 ³ / ₁₆ | 1 ³ / ₁₆ | 1 ¹¹ / ₁₆ | 1 ¹ / ₈ | 1 ⁵ / ₁₆ |
| | | 43 | 30 | 30 | 43 | 28 | 24 |
| 1½" PEX x ½" PEX x 1" PEX | Q4751551 | 1 ¹¹ / ₁₆ | 1 ³ / ₁₆ | 1 ³ / ₁₆ | 1 ¹¹ / ₁₆ | 1 ¹ / ₈ | 1 ³ / ₁₆ |
| | | 43 | 30 | 30 | 43 | 28 | 30 |
| 1½" PEX x ½" PEX x ¼" PEX | Q4751553 | 1 ¹¹ / ₁₆ | 1 ³ / ₁₆ | 1 ³ / ₁₆ | 1 ¹¹ / ₁₆ | 1 ¹ / ₈ | 1 ⁷ / ₁₆ |
| | | 43 | 30 | 30 | 43 | 28 | 37 |
| 2" PEX x 1½" PEX x ¾" PEX | Q4752575 | 2 ³ / ₁₆ | 1 ⁵ / ₁₆ | 1 ¹ / ₁₆ | 1 ¹¹ / ₁₆ | 1 ⁵ / ₁₆ | 1 ⁵ / ₁₆ |
| | | 56 | 34 | 34 | 43 | 33 | 24 |
| 2" PEX x 1½" PEX x 1" PEX | Q4752051 | 2 ³ / ₁₆ | 1 ⁵ / ₁₆ | 1 ¹ / ₁₆ | 1 ¹¹ / ₁₆ | 1 ⁵ / ₁₆ | 1 ³ / ₁₆ |
| | | 56 | 34 | 34 | 43 | 33 | 30 |
| 2" PEX x 1½" PEX x ¼" PEX | Q4752053 | 2 ³ / ₁₆ | 1 ³ / ₈ | 1 ³ / ₈ | 1 ¹¹ / ₁₆ | 1 ⁵ / ₁₆ | 1 ⁷ / ₁₆ |
| | | 56 | 35 | 35 | 43 | 33 | 37 |
| 2" PEX x 1½" PEX x ½" PEX | Q4752055 | 2 ³ / ₁₆ | 1 ³ / ₈ | 1 ³ / ₈ | 1 ¹¹ / ₁₆ | 1 ⁵ / ₁₆ | 1 ¹¹ / ₁₆ |
| | | 56 | 35 | 35 | 43 | 33 | 43 |
| 2" PEX x 1½" PEX x 2" PEX | Q4752152 | 2 ³ / ₁₆ | 1 ³ / ₄ | 1 ³ / ₄ | 1 ¹¹ / ₁₆ | 1 ¹ / ₁₆ | 2 ³ / ₁₆ |
| | | 56 | 44 | 44 | 43 | 26 | 56 |
| 2" PEX x 2" PEX x ½" PEX | Q4752250 | 2 ³ / ₁₆ | ¾ | ¾ | 2 ³ / ₁₆ | 1 ¹ / ₁₆ | ¾ |
| | | 56 | 19 | 19 | 56 | 26 | 19 |
| 2" PEX x 2" PEX x ¾" PEX | Q4752275 | 2 ³ / ₁₆ | 1 ⁵ / ₁₆ | 1 ⁵ / ₁₆ | 2 ³ / ₁₆ | 1 ⁵ / ₁₆ | 1 ⁵ / ₁₆ |
| | | 56 | 34 | 34 | 56 | 33 | 24 |
| 2" PEX x 2" PEX x 1" PEX | Q4752210 | 2 ³ / ₁₆ | 1 ⁵ / ₁₆ | 1 ⁵ / ₁₆ | 2 ³ / ₁₆ | 1 ⁵ / ₁₆ | 1 ³ / ₁₆ |
| | | 56 | 34 | 34 | 56 | 33 | 30 |
| 2" PEX x 2" PEX x ¼" PEX | Q4752213 | 2 ³ / ₁₆ | 1 ⁵ / ₁₆ | 1 ⁵ / ₁₆ | 2 ³ / ₁₆ | 1 ⁵ / ₁₆ | 1 ⁷ / ₁₆ |
| | | 56 | 34 | 34 | 56 | 33 | 37 |
| 2" PEX x 2" PEX x ½" PEX | Q4752215 | 2 ³ / ₁₆ | 1 ⁵ / ₁₆ | 1 ⁵ / ₁₆ | 2 ³ / ₁₆ | 1 ⁵ / ₁₆ | 1 ¹¹ / ₁₆ |
| | | 56 | 34 | 34 | 56 | 33 | 43 |

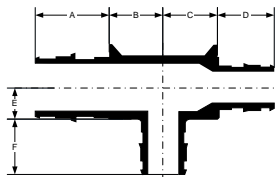

| ProPEX EP reducing tees | | A | B | C | D | E | F |
|--------------------------------|----------|---------------------------------|-------------------------------|-------------------------------|---------------------------------|--------------------------------|---------------------------------|
| Description | Part no. | in | in | in | in | in | in |
| | | mm | mm | mm | mm | mm | mm |
| 2½" PEX x 2" PEX x 1½" PEX | Q4752525 | 2 ¹³ / ₁₆ | 1 ⁵ / ₈ | 1 ⁵ / ₈ | 2 ³ / ₁₆ | 1 ⁵ / ₁₆ | 1 ¹ / ₁₆ |
| | | 72 | 41 | 41 | 56 | 33 | 43 |
| 2½" PEX x 2" PEX x 2" PEX | Q4752522 | 2 ¹³ / ₁₆ | 2 | 2 | 2 ³ / ₁₆ | 1 ⁵ / ₁₆ | 2 ³ / ₁₆ |
| | | 72 | 51 | 51 | 56 | 33 | 56 |
| 2½" PEX x 2½" PEX x ¾" PEX | Q4752557 | 2 ¹³ / ₁₆ | 1 ⁵ / ₈ | 1 ⁵ / ₈ | 2 ¹⁹ / ₁₆ | 1 ⁵ / ₁₆ | 1 ⁵ / ₁₆ |
| | | 72 | 29 | 29 | 72 | 33 | 24 |
| 2½" PEX x 2½" PEX x 1" PEX | Q4752510 | 2 ¹³ / ₁₆ | 1¼ | 1¼ | 2 ¹⁹ / ₁₆ | 1 ⁵ / ₁₆ | 1 ⁹ / ₁₆ |
| | | 72 | 32 | 32 | 72 | 33 | 30 |
| 2½" PEX x 2½" PEX x 1¼" PEX | Q4752513 | 2 ¹³ / ₁₆ | 1½ | 1½ | 2 ¹⁹ / ₁₆ | 1 ⁵ / ₁₆ | 1 ⁷ / ₁₆ |
| | | 72 | 38 | 38 | 72 | 33 | 37 |
| 2½" PEX x 2½" PEX x 1½" PEX | Q4752515 | 2 ¹³ / ₁₆ | 1 ⁵ / ₈ | 1 ⁵ / ₈ | 2 ¹³ / ₁₆ | 1 ⁵ / ₁₆ | 1 ¹ / ₁₆ |
| | | 72 | 41 | 41 | 72 | 33 | 43 |
| 2½" PEX x 2½" PEX x 2" PEX | Q4752520 | 2 ¹³ / ₁₆ | 2 | 2 | 2 ¹³ / ₁₆ | 1¼ | 2 ³ / ₁₆ |
| | | 72 | 51 | 51 | 72 | 32 | 56 |
| 3" PEX x 2" PEX x 2" PEX | Q4753220 | 3 ³ / ₈ | 2 | 2 | 2 ³ / ₁₆ | 1 ⁹ / ₁₆ | 2 ³ / ₁₆ |
| | | 86 | 51 | 51 | 56 | 39 | 56 |
| 3" PEX x 2½" PEX x 1½" PEX | Q4753215 | 3 ³ / ₈ | 1 ⁵ / ₈ | 1 ⁵ / ₈ | 2 ¹³ / ₁₆ | 1 ⁹ / ₁₆ | 1 ¹ / ₁₆ |
| | | 86 | 41 | 41 | 72 | 39 | 43 |
| 3" PEX x 2½" PEX x 2" PEX | Q4753252 | 3 ³ / ₈ | 2 | 2 | 2 ¹³ / ₁₆ | 1 ⁹ / ₁₆ | 2 ³ / ₁₆ |
| | | 86 | 51 | 51 | 72 | 39 | 56 |
| 3" PEX x 3" PEX x ¾" PEX | Q4753375 | 3 ³ / ₈ | 1 ⁵ / ₈ | 1 ⁵ / ₈ | 3 ³ / ₈ | 1 ⁹ / ₁₆ | 1 ⁵ / ₁₆ |
| | | 86 | 29 | 29 | 86 | 39 | 24 |
| 3" PEX x 3" PEX x 1" PEX | Q4753310 | 3 ³ / ₈ | 1¼ | 1¼ | 3 ³ / ₈ | 1 ⁹ / ₁₆ | 1 ⁹ / ₁₆ |
| | | 86 | 32 | 32 | 86 | 39 | 30 |
| 3" PEX x 3" PEX x 1¼" PEX | Q4753313 | 3 ³ / ₈ | 1½ | 1½ | 3 ³ / ₈ | 1 ⁹ / ₁₆ | 1 ⁷ / ₁₆ |
| | | 86 | 38 | 38 | 86 | 39 | 37 |
| 3" PEX x 3" PEX x 1½" PEX | Q4753315 | 3 ³ / ₈ | 1 ⁵ / ₈ | 1 ⁵ / ₈ | 3 ³ / ₈ | 1 ⁹ / ₁₆ | 1 ¹ / ₁₆ |
| | | 86 | 41 | 41 | 86 | 39 | 43 |
| 3" PEX x 3" PEX x 2" PEX | Q4753320 | 3 ³ / ₈ | 2 | 2 | 3 ³ / ₈ | 1 ⁹ / ₁₆ | 2 ¹³ / ₁₆ |
| | | 86 | 51 | 51 | 86 | 39 | 72 |
| 3" PEX x 3" PEX x 2½" PEX | Q4753325 | 3 ³ / ₈ | 2½ | 2½ | 3 ³ / ₈ | 1 ⁹ / ₁₆ | 2 ¹³ / ₁₆ |
| | | 86 | 64 | 64 | 86 | 39 | 72 |

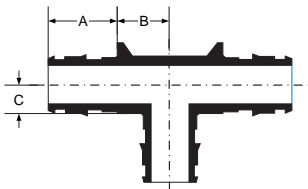

| ProPEX tees | | A | B | C |
|--------------------------------------|-----------|---------|--------|--------|
| Description | Part no. | in | in | in |
| | | mm | mm | mm |
| 1/2" PEX x 1/2" PEX x 1/2" PEX | Q4755050 | 3/4 | 9/16 | 3/8 |
| | | 19 | 15 | 10 |
| 1/2" PEX x 1/2" PEX x 1/2" PEX | LF4705050 | 11/16 | 9/16 | 5/16 |
| | | 18 | 14 | 8 |
| 3/4" PEX x 3/4" PEX x 3/4" PEX | Q4757575 | 15/16 | 11/16 | 1/2 |
| | | 24 | 18 | 13 |
| 3/4" PEX x 3/4" PEX x 3/4" PEX | LF4707575 | 15/16 | 11/16 | 3/8 |
| | | 24 | 18 | 10 |
| 1" PEX x 1" PEX x 1" PEX | Q4751010 | 13/16 | 7/8 | 11/16 |
| | | 30 | 22 | 18 |
| 1" PEX x 1" PEX x 1" PEX | LF4701010 | 13/16 | 7/8 | 9/16 |
| | | 30 | 22 | 14 |
| 1 1/4" PEX x 1 1/4" PEX x 1 1/4" PEX | Q4751313 | 17/16 | 15/16 | 15/16 |
| | | 37 | 25 | 24 |
| 1 1/2" PEX x 1 1/2" PEX x 1 1/2" PEX | Q4751515 | 1 11/16 | 1 3/16 | 1 1/8 |
| | | 43 | 30 | 28 |
| 2" PEX x 2" PEX x 2" PEX | Q4752000 | 2 3/16 | 1 9/16 | 1 5/8 |
| | | 56 | 40 | 41 |
| 2 1/2" PEX x 2 1/2" PEX x 2 1/2" PEX | Q4752500 | 2 13/16 | 2 7/16 | 1 5/16 |
| | | 72 | 62 | 34 |
| 3" PEX x 3" PEX x 3" PEX | Q4753000 | 3 3/8 | 2 3/4 | 1 7/16 |
| | | 86 | 70 | 37 |

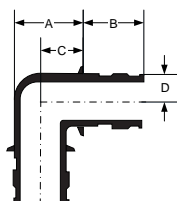

EP elbow

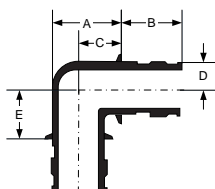

Brass elbow

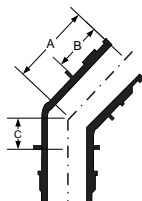

EP elbow

| ProPEX elbows | | A | B | C | D | E |
|-------------------------------------|-----------|---------|---------|--------|--------|------|
| Description | Part no. | in | in | in | in | in |
| | | mm | mm | mm | mm | mm |
| 1/2" PEX x 1/2" PEX EP Elbow | Q4760500 | 1 1/16 | 3/4 | 9/16 | 1/4 | |
| 3/4" PEX x 3/4" PEX EP Elbow | Q4760750 | 1 1/16 | 15/16 | 11/16 | 3/8 | |
| 3/4" PEX x 3/4" PEX Brass Elbow | LF4710750 | 1 1/16 | 15/16 | 11/16 | 3/8 | 3/8 |
| 1" PEX x 1" PEX EP Elbow | Q4761000 | 1 5/8 | 1 3/16 | 7/8 | 13/16 | |
| 1" PEX x 1" PEX Brass Elbow | LF4711000 | 1 1/4 | 1 3/16 | 7/8 | 13/16 | 9/16 |
| 1 1/4" PEX x 1 1/4" PEX EP Elbow | Q4761250 | 1 3/4 | 1 1/16 | 1 1/8 | 5/8 | |
| 1 1/2" PEX x 1 1/2" PEX EP Elbow | Q4761500 | 1 7/8 | 1 11/16 | 1 3/16 | 1 1/16 | |
| 1 1/2" PEX x 1 1/2" PEX 45 Elbow | Q4761515 | 2 5/16 | 1 11/16 | 5/8 | | |
| 2" PEX x 2" PEX EP Elbow | Q4762000 | 2 9/16 | 2 3/16 | 1 5/8 | 1 5/16 | |
| 2" PEX x 2" PEX 45 Elbow | Q4762020 | 2 15/16 | 2 3/16 | 3/4 | | |
| 2 1/2" PEX x 2 1/2" PEX EP Elbow | Q4762500 | 3 5/16 | 2 13/16 | 2 1/8 | 1 3/16 | |
| 2 1/2" PEX x 2 1/2" PEX 45 Elbow | Q4762525 | 3 13/16 | 2 13/16 | 1 | | |
| 3" PEX x 3" PEX EP Elbow | Q4763000 | 3 15/16 | 3 3/8 | 2 1/2 | 1 7/16 | |
| 3" PEX x 3" PEX 45 Elbow | Q4763030 | 4 1/2 | 3 3/8 | 1 1/8 | | |
| | | 114 | 86 | 28 | | |

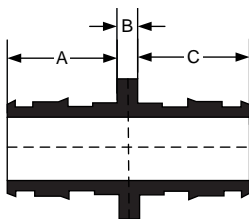

| ProPEX couplings | | A | B | C |
|-------------------------|-----------|---------------|----------|---------------|
| Description | Part no. | in | in | in |
| | | mm | mm | mm |
| 1/2" PEX x 1/2" PEX | Q4775050 | 3/4 19 | 1/8 3 | 3/4 19 |
| | LF4545050 | 11/16 18 | 1/8 3 | 11/16 18 |
| 3/4" PEX x 3/4" PEX | Q4777575 | 15/16 24 | 1/8 3 | 15/16 24 |
| | LF4547575 | 15/16 24 | 1/8 3 | 15/16 24 |
| 1" PEX x 1" PEX | Q4771010 | 1 3/16 30 | 1/8 3 | 1 3/16 30 |
| | LF4541010 | 1 3/16 30 | 1/8 3 | 1 3/16 30 |
| 1 1/4" PEX x 1 1/4" PEX | Q4771313 | 1 7/16 37 | 1/8 3 | 1 7/16 37 |
| 1 1/2" PEX x 1 1/2" PEX | Q4771515 | 1 11/16 44 | 1/8 3 | 1 11/16 44 |
| 2" PEX x 2" PEX | Q4772020 | 2 3/16 56 | 1/4 6 | 2 3/16 56 |
| | Q4772525 | 2 13/16 72 | 1/4 6 | 2 13/16 72 |
| 3" PEX x 3" PEX | Q4773030 | 3 3/8 86 | 1/4 6 | 3 3/8 86 |

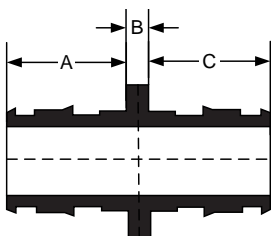

| ProPEX reducing couplings | | A | B | C |
|----------------------------|-----------|---------|-----|---------|
| Description | Part no. | in | in | in |
| | | mm | mm | mm |
| 3/4" PEX x 1/2" PEX | Q4775075 | 15/16 | 1/8 | 3/4 |
| | | 24 | 3 | 19 |
| 1" PEX x 3/4" PEX | Q4777510 | 13/16 | 1/8 | 15/16 |
| | LF4547510 | 30 | 3 | 24 |
| 1 1/4" PEX x 3/4" PEX | Q4771307 | 13/16 | 1/8 | 15/16 |
| | | 37 | 3 | 24 |
| 1 1/4" PEX x 1" PEX | Q4771310 | 17/16 | 1/8 | 13/16 |
| | | 37 | 3 | 30 |
| 1 1/2" PEX x 3/4" PEX | Q4771507 | 1 11/16 | 1/8 | 15/16 |
| | | 44 | 3 | 24 |
| 1 1/2" PEX x 1" PEX | Q4771510 | 1 11/16 | 1/8 | 13/16 |
| | | 44 | 3 | 30 |
| 1 1/2" PEX x 1 1/4" PEX | Q4771513 | 1 11/16 | 1/8 | 17/16 |
| | | 44 | 3 | 37 |
| 2" PEX x 1 1/2" PEX | Q4772015 | 2 3/16 | 1/4 | 1 11/16 |
| | | 56 | 6 | 44 |
| 2 1/2" PEX x 1 1/4" PEX | Q4772513 | 2 13/16 | 1/4 | 17/16 |
| | | 72 | 6 | 37 |
| 2 1/2" PEX x 1 1/2" PEX | Q4772515 | 2 13/16 | 1/4 | 1 11/16 |
| | | 72 | 6 | 44 |
| 2 1/2" PEX x 2" PEX | Q4772520 | 2 13/16 | 1/4 | 2 3/16 |
| | | 72 | 6 | 56 |
| 3" PEX x 2" PEX | Q4773020 | 3 3/8 | 1/4 | 2 3/16 |
| | | 86 | 6 | 56 |
| 3" PEX x 2 1/2" PEX | Q4773025 | 3 3/8 | 1/4 | 2 13/16 |
| | | 86 | 6 | 72 |

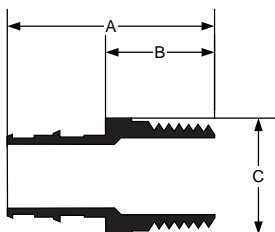

| ProPEX brass male threaded adapters | | A | B | C |
|-------------------------------------|-----------|---------|--------|-------|
| Description | Part no. | in | in | in |
| | | mm | mm | mm |
| 3/8" PEX x 1/2" NPT | LF4523850 | 1 5/8 | 1 | 7/8 |
| | | 41 | 25 | 22 |
| 1/2" PEX x 1/2" NPT | Q5525050 | 1 5/8 | 7/8 | 7/8 |
| | | 41 | 23 | 22 |
| | LF4525050 | 1 11/16 | 15/16 | 7/8 |
| | | 42 | 24 | 22 |
| 1/2" PEX x 3/4" NPT | LF4525075 | 1 13/16 | 1 1/16 | 1 1/8 |
| | | 45 | 27 | 29 |
| 3/4" PEX x 3/4" NPT | LF4527575 | 1 7/8 | 1 | 1 1/8 |
| | | 48 | 25 | 29 |
| | Q5527575 | 1 7/8 | 7/8 | 1 1/8 |
| | | 47 | 23 | 29 |
| 3/4" PEX x 1" NPT | LF4527510 | 2 1/4 | 1 1/4 | 1 3/8 |
| | | 56 | 32 | 35 |
| | Q5527510 | 2 | 1 1/16 | 1 3/8 |
| | | 51 | 27 | 35 |
| 1" PEX x 3/4" NPT | LF4521075 | 2 1/4 | 1 1/16 | 1 1/4 |
| | | 57 | 27 | 32 |
| | Q5521075 | 2 1/16 | 1 1/16 | 1 1/4 |
| | | 53 | 27 | 32 |
| 1" PEX x 1" NPT | LF4521010 | 2 5/16 | 1 1/8 | 1 3/8 |
| | | 59 | 29 | 35 |
| | Q5521010 | 2 1/4 | 1 1/16 | 1 3/8 |
| | | 57 | 27 | 35 |
| 1 1/4" PEX x 1 1/4" NPT | LF4521313 | 2 5/8 | 1 3/16 | 1 3/4 |
| | | 66 | 30 | 44 |
| | Q5521313 | 2 1/2 | 1 1/16 | 1 3/4 |
| | | 64 | 27 | 44 |

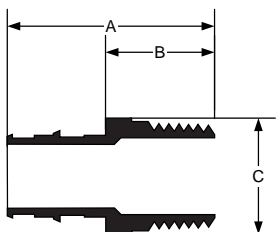

| ProPEX brass male threaded adapters | | A | B | C |
|-------------------------------------|-----------|--|--------------------------------------|-------------------------------------|
| Description | Part no. | in | in | in |
| | | mm | mm | mm |
| 1½" PEX x 1½" NPT | LF4521515 | 3 76 | 1¼ 32 | 2 51 |
| | Q5521515 | 2 ¹⁵ / ₁₆ 74 | 1¼ 32 | 2 51 |
| 2" PEX x 2" NPT | LF4522020 | 3 ⁹ / ₁₆ 90 | 1½ 35 | 2 ³ / ₈ 60 |
| | Q5522020 | 3 ⁷ / ₁₆ 87 | 1 ⁵ / ₁₆ 33 | 2 ³ / ₈ 60 |
| 2½" PEX x 2½" NPT | LF4522525 | 4 ¹³ / ₁₆ 123 | 2 51 | 3¼ 83 |
| | LF4523030 | 5½ 140 | 2½ 55 | 3¾ 95 |

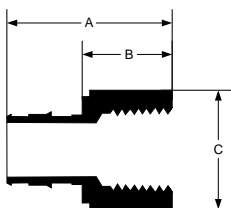

| ProPEX brass female threaded adapters | | A | B | C |
|---------------------------------------|-----------|--------|--------|--------|
| Description | Part no. | in | in | in |
| | | mm | mm | mm |
| 1/2" PEX x 1/2" NPT | Q5575050 | 1 9/16 | 7/8 | 1 |
| | LF4575050 | 40 | 22 | 25 |
| 1/2" PEX x 3/4" NPT | LF4575075 | 1 9/16 | 7/8 | 1 |
| | | 40 | 22 | 25 |
| 1/2" PEX x 3/4" NPT | LF4575075 | 1 3/4 | 1 1/16 | 1 3/16 |
| | | 44 | 26 | 30 |
| 3/4" PEX x 3/4" NPT | Q5577575 | 1 7/8 | 7/8 | 1 3/16 |
| | LF4577575 | 47 | 23 | 30 |
| 3/4" PEX x 3/4" NPT | LF4577575 | 1 7/8 | 7/8 | 1 3/16 |
| | | 47 | 23 | 30 |
| 3/4" PEX x 1" NPT | Q5577510 | 2 1/8 | 1 3/16 | 1 1/2 |
| | LF4577510 | 54 | 32 | 38 |
| 3/4" PEX x 1" NPT | LF4577510 | 2 3/16 | 1 1/4 | 1 1/2 |
| | | 56 | 32 | 38 |
| 1" PEX x 1" NPT | Q5571010 | 2 3/8 | 1 3/16 | 1 1/2 |
| | LF4571010 | 60 | 30 | 38 |
| 1" PEX x 1" NPT | LF4571010 | 2 3/8 | 1 3/16 | 1 1/2 |
| | | 60 | 30 | 38 |
| 1 1/4" PEX x 1 1/4" NPT | Q5571313 | 2 9/16 | 1 1/8 | 2 |
| | LF4571313 | 65 | 28 | 51 |
| 1 1/4" PEX x 1 1/4" NPT | LF4571313 | 2 9/16 | 1 1/8 | 2 |
| | | 65 | 28 | 51 |
| 1 1/2" PEX x 1 1/2" NPT | Q5571515 | 2 7/8 | 1 1/8 | 2 1/4 |
| | LF4571515 | 73 | 29 | 57 |
| 1 1/2" PEX x 1 1/2" NPT | LF4571515 | 2 7/8 | 1 1/8 | 2 1/4 |
| | | 73 | 29 | 57 |
| 2" PEX x 2" NPT | Q5572020 | 3 9/16 | 1 3/8 | 3 |
| | LF4572020 | 90 | 35 | 76 |
| 2" PEX x 2" NPT | LF4572020 | 3 9/16 | 1 3/8 | 3 |
| | | 90 | 35 | 76 |

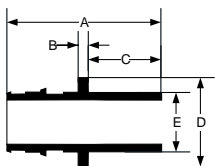

| ProPEX brass fitting adapters | | A | B | C | D | E |
|-------------------------------|-----------|---------------|----------|-------------|--------------|-------------|
| Description | Part no. | in | in | in | in | in |
| | | mm | mm | mm | mm | mm |
| 1/2" PEX x 1/2" Copper | LF4505050 | 1 3/8 35 | 1/8 3 | 9/16 14 | 3/4 19 | 5/8 16 |
| | Q5505050 | 1 11/16 43 | 1/8 3 | 7/8 22 | 3/4 19 | 5/8 16 |
| 1/2" PEX x 3/4" Copper | LF4505075 | 1 5/8 42 | 1/8 3 | 13/16 21 | 15/16 23 | 7/8 22 |
| | Q4506350 | 1 9/16 39 | 1/8 3 | 9/16 14 | 1 1/16 26 | 5/8 16 |
| 5/8" PEX x 3/4" Copper | Q4506375 | 1 13/16 46 | 1/8 3 | 13/16 21 | 15/16 24 | 7/8 22 |
| | LF4507550 | 1 5/8 41 | 1/8 3 | 9/16 14 | 1 1/8 28 | 5/8 16 |
| 3/4" PEX x 1/2" Copper | Q5507550 | 1 15/16 50 | 1/8 3 | 7/8 22 | 1 1/8 28 | 5/8 16 |
| | LF4507575 | 1 7/8 48 | 1/8 3 | 13/16 21 | 1 1/8 28 | 7/8 22 |
| 3/4" PEX x 3/4" Copper | Q5507575 | 2 1/16 53 | 1/8 3 | 1 25 | 1 1/8 28 | 7/8 22 |
| | LF4507510 | 2 1/16 53 | 1/8 3 | 1 25 | 1 3/16 30 | 1 1/8 28 |
| 3/4" PEX x 1" Copper | Q5507510 | 2 1/16 53 | 1/8 3 | 1 25 | 1 1/8 29 | 1 1/8 28 |
| | LF4501010 | 2 1/4 58 | 1/8 3 | 1 25 | 1 3/8 35 | 1 1/8 29 |
| 1" PEX x 1" Copper | Q5501010 | 2 5/16 59 | 1/8 3 | 1 25 | 1 3/8 35 | 1 1/8 29 |
| | LF4501313 | 2 5/8 66 | 1/8 3 | 1 25 | 1 5/8 42 | 1 3/8 35 |
| 1 1/4" PEX x 1 1/4" Copper | Q5501313 | 2 11/16 69 | 1/8 3 | 1 1/8 29 | 1 3/4 44 | 1 1/8 35 |

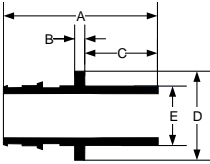

| ProPEX brass fitting adapters | | A | B | C | D | E |
|-------------------------------|-----------|---------------------------------|----|--------------------------------|---------------------------------|-------------------------------|
| Description | Part no. | in | in | in | in | in |
| | | mm | mm | mm | mm | mm |
| 1½" PEX x 1½" Copper | LF4501515 | 3 | ⅛ | 1 ³ / ₁₆ | 1 ⁷ / ₈ | 1 ⁵ / ₈ |
| | | 76 | 3 | 29 | 48 | 41 |
| | Q5501515 | 3 ³ / ₈ | ⅛ | 1 ⁹ / ₁₆ | 1 ⁷ / ₈ | 1 ⁵ / ₈ |
| | | 86 | 3 | 40 | 48 | 41 |
| 2" PEX x 2" Copper | LF4502020 | 3 ¹³ / ₁₆ | ¼ | 1 ⁷ / ₁₆ | 2 ⁵ / ₈ | 2 ¹ / ₈ |
| | | 97 | 6 | 36 | 66 | 54 |
| | Q5502020 | 4 ¹ / ₈ | ¼ | 1 ³ / ₄ | 2 ¹¹ / ₁₆ | 2 ¹ / ₈ |
| | | 105 | 6 | 44 | 68 | 54 |

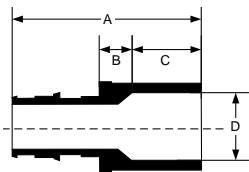

| ProPEX brass sweat adapters | | A | B | C | D |
|-----------------------------|-----------|---------|------|-------|-------|
| Description | Part no. | in | in | in | in |
| | | mm | mm | mm | mm |
| 3/8" PEX x 1/2" Copper | LF4513850 | 1 5/16 | 1/4 | 1/2 | 5/8 |
| | | 34 | 6 | 13 | 16 |
| 1/2" PEX x 1/2" Copper | LF4515050 | 1 3/8 | 3/16 | 1/2 | 5/8 |
| | | 35 | 5 | 13 | 16 |
| | Q5515050 | 1 3/8 | 3/16 | 1/2 | 5/8 |
| | | 35 | 5 | 13 | 16 |
| 1/2" PEX x 3/4" Copper | LF4515075 | 1 5/8 | 3/16 | 3/4 | 7/8 |
| | | 41 | 5 | 19 | 22 |
| 3/4" PEX x 1/2" Copper | LF4517550 | 1 11/16 | 1/4 | 1/2 | 5/8 |
| | | 42 | 6 | 13 | 16 |
| | Q5517550 | 1 11/16 | 1/4 | 1/2 | 5/8 |
| | | 42 | 6 | 13 | 16 |
| 3/4" PEX x 3/4" Copper | LF4517575 | 1 7/8 | 3/16 | 3/4 | 7/8 |
| | | 47 | 5 | 19 | 22 |
| | Q5517575 | 1 7/8 | 3/16 | 3/4 | 7/8 |
| | | 47 | 5 | 19 | 22 |
| 3/4" PEX x 1" Copper | LF4517510 | 2 1/8 | 1/4 | 15/16 | 1 1/8 |
| | | 53 | 6 | 23 | 29 |
| | Q5517510 | 2 1/8 | 1/4 | 15/16 | 1 1/8 |
| 1" PEX x 1" Copper | LF4511010 | 2 1/4 | 3/16 | 15/16 | 1 1/8 |
| | | 58 | 5 | 23 | 29 |
| | Q5511010 | 2 1/4 | 3/16 | 15/16 | 1 1/8 |
| | | 58 | 5 | 23 | 29 |
| 1 1/4" PEX x 1 1/4" Copper | LF4511313 | 2 5/8 | 3/16 | 1 | 1 3/8 |
| | | 66 | 5 | 25 | 35 |
| | Q5511313 | 2 5/8 | 3/16 | 1 | 1 3/8 |
| | | 66 | 5 | 25 | 35 |

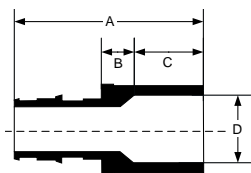

| ProPEX brass sweat adapters | | A | B | C | D |
|-----------------------------|-----------|--------------------------------|--------------------------------|---------------------------------|-------------------------------|
| Description | Part no. | in | in | in | in |
| | | mm | mm | mm | mm |
| 1½" PEX x 1½" Copper | LF4511515 | 3 ³ / ₁₆ | ¼ | 1 ¹ / ₁₆ | 1 ⁵ / ₈ |
| | Q5511515 | 78 | 6 | 28 | 41 |
| 2" PEX x 2" Copper | LF4512020 | 3 ³ / ₄ | ¼ | 1 ⁵ / ₁₆ | 2 ¹ / ₈ |
| | Q5512020 | 95 | 6 | 34 | 54 |
| 2½" PEX x 2½" Copper | LF4512525 | 4 ⁹ / ₁₆ | 5 ¹ / ₁₆ | 1 ⁷ / ₁₆ | 2 ⁵ / ₈ |
| | | 116 | 8 | 37 | 67 |
| 3" PEX x 3" Copper | LF4513030 | 5 ⁵ / ₁₆ | 5 ¹ / ₁₆ | 1 ¹¹ / ₁₆ | 3 ¹ / ₈ |
| | | 135 | 8 | 42 | 80 |

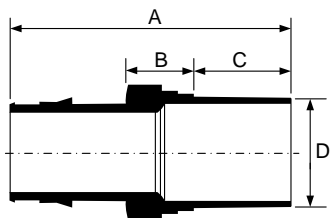

| ProPEX LF brass copper press fitting adapters | | A | B | C | D |
|--|------------|---------|--------|---------|-------|
| Description | Part no. | in | in | in | in |
| | | mm | mm | mm | mm |
| 1/2" PEX x 1/2" copper | LFP4505050 | 2 | 9/16 | 3/4 | 5/8 |
| | | 51 | 14 | 19 | 16 |
| 3/4" PEX x 3/4" copper | LFP4507575 | 2 3/8 | 5/8 | 7/8 | 7/8 |
| | | 61 | 15 | 22 | 22 |
| 1" PEX x 1" copper | LFP4501010 | 2 7/8 | 1 1/16 | 1 | 1 1/8 |
| | | 73 | 17 | 25 | 29 |
| 1 1/4" PEX x 1 1/4" copper | LFP4501313 | 3 5/16 | 3/4 | 1 1/16 | 1 3/8 |
| | | 84 | 19 | 27 | 35 |
| 1 1/2" PEX x 1 1/2" copper | LFP4501515 | 3 3/8 | 3/4 | 1 1/16 | 1 5/8 |
| | | 99 | 19 | 36 | 41 |
| 2" PEX x 2" copper | LFP4502020 | 4 5/8 | 1 5/16 | 1 9/16 | 2 1/8 |
| | | 118 | 24 | 40 | 54 |
| 2 1/2" PEX x 2 1/2" copper | LFP4502525 | 5 7/8 | 1 3/8 | 1 5/8 | 2 5/8 |
| | | 149 | 36 | 41 | 67 |
| 3" PEX x 3" copper | LFP4503030 | 6 11/16 | 1 1/2 | 1 13/16 | 3 1/8 |
| | | 169 | 38 | 46 | 79 |

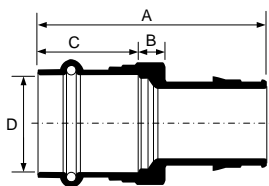

1/2" to 2" sizes

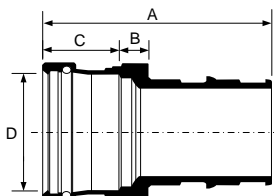

2 1/2" to 3" sizes

| ProPEX LF brass copper press adapters | | A | B | C | D |
|---------------------------------------|------------|---------|--------|---------|-------|
| Description | Part no. | in | in | in | in |
| | | mm | mm | mm | mm |
| 1/2" PEX x 1/2" copper | LFP4515050 | 2 1/16 | 7/16 | 7/8 | 5/8 |
| | | 53 | 11 | 22 | 16 |
| 3/4" PEX x 3/4" copper | LFP4517575 | 2 3/8 | 9/16 | 7/8 | 7/8 |
| | | 61 | 14 | 22 | 22 |
| 1" PEX x 1" copper | LFP4511010 | 2 11/16 | 5/16 | 1 3/16 | 1 1/8 |
| | | 68 | 8 | 30 | 29 |
| 1 1/4" PEX x 1 1/4" copper | LFP4511313 | 3 1/8 | 9/16 | 1 | 1 3/8 |
| | | 77 | 14 | 25 | 35 |
| 1 1/2" PEX x 1 1/2" copper | LFP4511515 | 3 5/8 | 9/16 | 1 5/16 | 1 5/8 |
| | | 91 | 14 | 34 | 42 |
| 2" PEX x 2" copper | LFP4512020 | 4 5/8 | 1/2 | 2 | 2 1/8 |
| | | 118 | 12 | 51 | 54 |
| 2 1/2" PEX x 2 1/2" copper | LFP4512525 | 5 1/4 | 1 1/16 | 1 3/4 | 2 5/8 |
| | | 133 | 17 | 44 | 67 |
| 3" PEX x 3" copper | LFP4513030 | 6 1/8 | 1 5/16 | 1 15/16 | 3 1/8 |
| | | 156 | 24 | 49 | 80 |

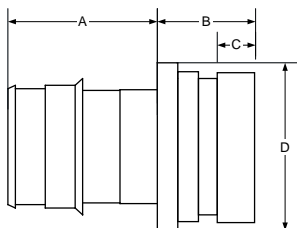

| ProPEX LF brass groove fitting adapters | | A | B | C | D |
|--|------------|---------------------------------|-------------------------------|-------------------------------|---------------------------------|
| Description | Part no. | in | in | in | in |
| | | mm | mm | mm | mm |
| 2" PEX x 2" CTS Groove | LFV2962020 | 2 ¹ / ₈ | 1 ¹ / ₂ | 5 ⁵ / ₈ | 2 ¹¹ / ₁₆ |
| | | 54 | 38 | 15 | 68 |
| 2" PEX x 2 ¹ / ₂ " CTS Groove | LFV2962025 | 2 ¹ / ₈ | 1 ¹ / ₂ | 5 ⁵ / ₈ | 2 ¹¹ / ₁₆ |
| | | 54 | 38 | 15 | 68 |
| 2 ¹ / ₂ " PEX x 2 ¹ / ₂ " CTS Groove | LFV2962525 | 2 ¹³ / ₁₆ | 1 ¹ / ₂ | 5 ⁵ / ₈ | 3 ³ / ₈ |
| | | 72 | 38 | 15 | 86 |
| 3" PEX x 3" CTS Groove | LFV2963030 | 3 ³ / ₈ | 1 ¹ / ₂ | 5 ⁵ / ₈ | 3 ¹³ / ₁₆ |
| | | 86 | 38 | 15 | 96 |
| 2" PEX x 2" IPS Groove | LFV2972020 | 2 ¹ / ₈ | 1 ¹ / ₂ | 5 ⁵ / ₈ | 2 ¹¹ / ₁₆ |
| | | 54 | 38 | 15 | 68 |
| 2" PEX x 2 ¹ / ₂ " IPS Groove | LFV2972025 | 2 ¹ / ₈ | 1 ¹ / ₂ | 5 ⁵ / ₈ | 2 ⁷ / ₈ |
| | | 54 | 38 | 15 | 73 |
| 2 ¹ / ₂ " PEX x 2" IPS Groove | LFV2972520 | 2 ¹³ / ₁₆ | 1 ¹ / ₂ | 5 ⁵ / ₈ | 3 ³ / ₈ |
| | | 72 | 38 | 15 | 86 |
| 2 ¹ / ₂ " PEX x 2 ¹ / ₂ " IPS Groove | LFV2972525 | 2 ¹³ / ₁₆ | 1 ¹ / ₂ | 5 ⁵ / ₈ | 3 ³ / ₈ |
| | | 72 | 38 | 15 | 86 |

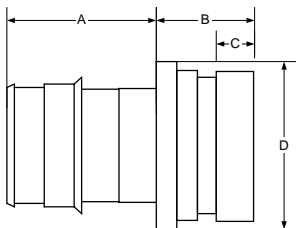

| ProPEX LF brass groove fitting adapters | | A | B | C | D |
|---|------------|---------------------------------|----|-----|---------------------------------|
| Description | Part no. | in | in | in | in |
| | | mm | mm | mm | mm |
| 2½" PEX x 3" IPS Groove | LFV2972530 | 2 ¹³ / ₁₆ | 1½ | 5/8 | 3½ |
| | | 72 | 38 | 15 | 89 |
| 3" PEX x 2½" IPS Groove | LFV2973025 | 3 ³ / ₈ | 1½ | 5/8 | 3 ¹³ / ₁₆ |
| | | 86 | 38 | 15 | 96 |
| 3" PEX x 3" IPS Groove | LFV2973030 | 3 ³ / ₈ | 1½ | 5/8 | 3 ¹³ / ₁₆ |
| | | 86 | 38 | 15 | 96 |

| ProPEX LF brass flange adapter | | A | B | C | D |
|--------------------------------|-----------|--------------------------------|-----|---------------------------------|-----|
| Description | Part no. | in | in | in | in |
| | | mm | mm | mm | mm |
| 2½" PEX x Flange | LF2982525 | 3¾ | 5/8 | 2 ¹³ / ₁₆ | 7 |
| | | 96 | 16 | 72 | 178 |
| 3" PEX x Flange | LF2983030 | 4 ⁵ / ₁₆ | 5/8 | 4 ¹ / ₁₆ | 7½ |
| | | 110 | 16 | 104 | 191 |

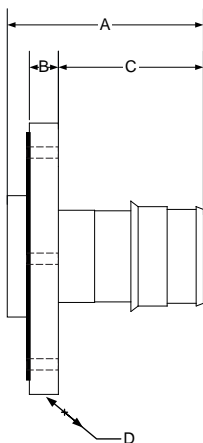

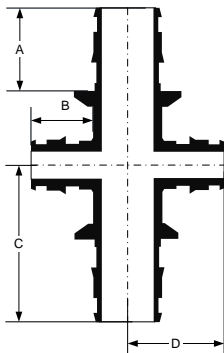

| ProPEX EP opposing-port tees | | A | B | C | D |
|--|----------|---------------------------------|--------------------------------|---------------------------------|---------------------------------|
| Description | Part no. | in | in | in | in |
| | | mm | mm | mm | mm |
| 1" PEX x 1" PEX x ¾" PEX x ¾" PEX | Q4801075 | 1 ³ / ₁₆ | 1 ⁵ / ₁₆ | 2 ¹ / ₁₆ | 1 ⁵ / ₈ |
| | | 30 | 24 | 53 | 41 |
| 1¼" PEX x 1¼" PEX x ¾" PEX x ¾" PEX | Q4801375 | 1 ⁷ / ₁₆ | 1 ⁵ / ₁₆ | 2 ³ / ₈ | 1¾ |
| | | 37 | 24 | 60 | 44 |
| 1½" PEX x 1½" PEX x ¾" PEX x ¾" PEX | Q4801575 | 1 ¹¹ / ₁₆ | 1 ⁵ / ₁₆ | 2 ¹¹ / ₁₆ | 1 ¹⁵ / ₁₆ |
| | | 43 | 24 | 69 | 49 |
| 2" PEX x 2" PEX x ¾" PEX x ¾" PEX | Q4802075 | 2 ³ / ₁₆ | 1 ⁵ / ₁₆ | 3 ³ / ₁₆ | 2 |
| | | 56 | 24 | 81 | 51 |

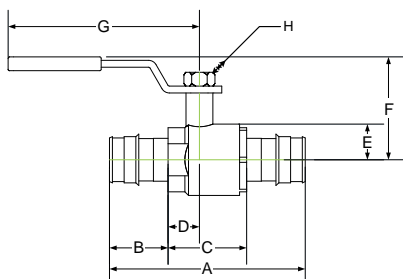

| ProPEX brass ball valves | | A | B | C | D | E | F | G | H |
|----------------------------|------------|---------|---------|---------|-------|-------|---------|--------|------|
| Description | Part no. | in | in | in | in | in | in | in | in |
| | | mm | mm | mm | mm | mm | mm | mm | mm |
| 1/2" PEX x 1/2" PEX | A3205050 | 2 1/2 | 1 1/8 | 1 1/8 | 3/8 | 1/2 | 1 11/16 | 3 3/8 | 3/8 |
| | LFC4825050 | 64 | 18 | 27 | 10 | 12 | 43 | 86 | 10 |
| 3/4" PEX x 3/4" PEX | A3207575 | 3 3/8 | 1 5/8 | 1 1/2 | 1/2 | 1/2 | 1 7/8 | 3 3/8 | 3/8 |
| | LFC4827575 | 86 | 24 | 38 | 12 | 12 | 47 | 86 | 10 |
| 1" PEX x 1" PEX | A3201010 | 4 3/8 | 1 3/8 | 1 13/16 | 3/4 | 13/16 | 1 7/8 | 4 7/16 | 1/2 |
| | LFC4821010 | 106 | 30 | 46 | 19 | 20 | 48 | 114 | 12 |
| 1 1/4" PEX x 1 1/4" PEX | A3201313 | 4 13/16 | 1 7/8 | 1 15/16 | 5/8 | 15/16 | 2 1/4 | 4 7/16 | 1/2 |
| | LFC4821313 | 122 | 37 | 49 | 17 | 24 | 58 | 114 | 12 |
| 1 1/2" PEX x 1 1/2" PEX | A3201515 | 5 11/16 | 1 11/16 | 2 1/8 | 15/16 | 1 1/8 | 2 11/16 | 5 9/16 | 9/16 |
| | LFC4821515 | 145 | 43 | 58 | 23 | 28 | 69 | 142 | 14 |
| 2" PEX x 2" PEX | A3202020 | 7 1/8 | 2 1/8 | 2 13/16 | 1 1/8 | 1 7/8 | 3 3/8 | 5 9/16 | 9/16 |
| | LFC4822020 | 181 | 55 | 72 | 28 | 37 | 86 | 142 | 14 |

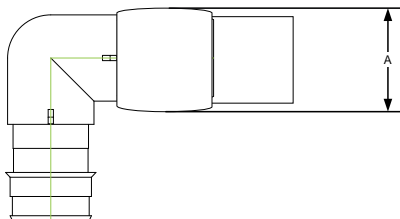

| ProPEX ring installed diameter | | A |
|--------------------------------|----------|---------|
| Description | Part no. | in |
| | | mm |
| 1/2" ProPEX ring with stop | Q4690512 | 15/16 |
| | | 24 |
| 3/4" ProPEX ring with stop | Q4690756 | 1 1/4 |
| | | 32 |
| 1" ProPEX ring with stop | Q4691000 | 1 9/16 |
| | | 40 |
| 1 1/4" ProPEX ring with stop | Q4691250 | 1 13/16 |
| | | 47 |
| 1 1/2" ProPEX ring with stop | Q4691500 | 2 1/16 |
| | | 53 |
| 2" ProPEX ring with stop | Q4692000 | 2 15/16 |
| | | 74 |
| 2 1/2" ProPEX ring with stop | Q4692500 | 3 9/16 |
| | | 91 |
| 3" ProPEX ring with stop | Q4693000 | 4 1/4 |
| | | 108 |

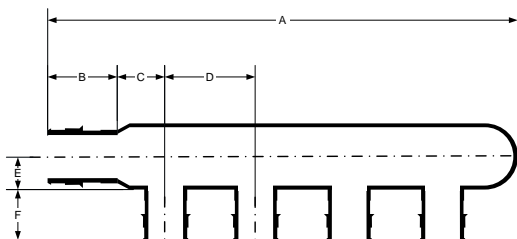

| EP branch multiport tees | | A | B | C | D | E | F |
|---|----------|---------|--------|--------|-------|--------|--------|
| Description | Part no. | in | in | in | in | in | in |
| | | mm | mm | mm | mm | mm | mm |
| 3/4" EP Branch Multiport Tee, 3 outlets | Q2237550 | 5/8 | 15/16 | 5/8 | 1 1/4 | 7/16 | 3/4 |
| | | 131 | 24 | 16 | 32 | 12 | 19 |
| 1 1/4" EP Branch Multiport Tee, 3 outlets | Q2231375 | 6 7/8 | 1 7/16 | 7/8 | 1 3/4 | 1 1/16 | 1 5/16 |
| | | 174 | 37 | 23 | 44 | 18 | 24 |
| 3/4" EP Branch Multiport Tee, 4 outlets | Q2247550 | 6 3/8 | 1 5/16 | 5/8 | 1 1/4 | 7/16 | 3/4 |
| | | 163 | 24 | 16 | 32 | 12 | 19 |
| 1" EP Branch Multiport Tee, 4 outlets | Q2241050 | 6 11/16 | 1 3/16 | 1 3/16 | 1 1/4 | 5/8 | 3/4 |
| | | 170 | 30 | 21 | 32 | 15 | 19 |
| 3/4" EP Branch Multiport Tee, 6 outlets | Q2267550 | 8 7/8 | 1 5/16 | 5/8 | 1 1/4 | 7/16 | 3/4 |
| | | 226 | 24 | 16 | 32 | 12 | 19 |
| 1" EP Branch Multiport Tee, 6 outlets | Q2261050 | 9 1/4 | 1 3/16 | 5/8 | 1 1/4 | 9/16 | 3/4 |
| | | 235 | 30 | 16 | 32 | 14 | 19 |

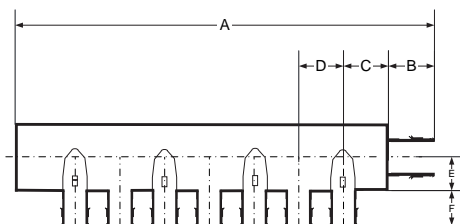

| Commercial EP branch multiport tees | | A | B | C | D | E | F |
|---|----------|---------------------------------|---------------------------------|-------------------------------|-------------------------------|--------------------------------|-----|
| Description | Part no. | in | in | in | in | in | in |
| | | mm | mm | mm | mm | mm | mm |
| 3/4" EP Branch Multiport Tee, 7 outlets | Q2277550 | 8 ¹¹ / ₁₆ | 1 ¹⁵ / ₁₆ | 1 ¹ / ₈ | 7 ⁷ / ₈ | 1 ¹ / ₁₆ | 3/4 |
| 3/4" EP Branch Multiport Tee, 8 outlets | Q2287550 | 9 ⁹ / ₁₆ | 1 ¹⁵ / ₁₆ | 1 ¹ / ₈ | 7 ⁷ / ₈ | 1 ¹ / ₁₆ | 3/4 |
| 1" EP Branch Multiport Tee, 7 outlets | Q2271051 | 8 ⁷ / ₈ | 1 ³ / ₁₆ | 1 ¹ / ₈ | 7 ⁷ / ₈ | 1 ¹ / ₁₆ | 3/4 |
| 1" EP Branch Multiport Tee, 8 outlets | Q2281051 | 9 ¹³ / ₁₆ | 1 ³ / ₁₆ | 1 ¹ / ₈ | 7 ⁷ / ₈ | 1 ¹ / ₁₆ | 3/4 |
| 1" EP Branch Multiport Tee, 10 outlets | Q2101051 | 11 ⁹ / ₁₆ | 1 ³ / ₁₆ | 1 ¹ / ₈ | 7 ⁷ / ₈ | 1 ¹ / ₁₆ | 3/4 |
| 1" EP Branch Multiport Tee, 12 outlets | Q2121051 | 13 ³ / ₈ | 1 ³ / ₁₆ | 1 ¹ / ₈ | 7 ⁷ / ₈ | 1 ¹ / ₁₆ | 3/4 |

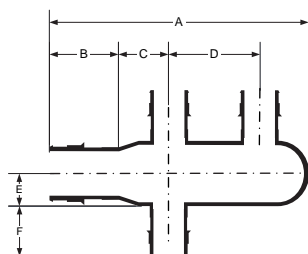

| EP branch opposing-port multiport tees | | A | B | C | D | E | F |
|---|----------|--------------------------------|---------------------------------|-------------------------------|-------------------------------|--------------------------------|-----|
| Description | Part no. | in | in | in | in | in | in |
| | | mm | mm | mm | mm | mm | mm |
| 3/4" EP Branch Opposing-port Multiport Tee, 3 outlets | Q2337550 | 3 ⁹ / ₁₆ | 1 ¹⁵ / ₁₆ | 5 ⁵ / ₈ | 1 ¹ / ₄ | 7 ⁷ / ₁₆ | 3/4 |
| 3/4" EP Branch Opposing-port Multiport Tee, 4 outlets | Q2347550 | 3 ⁹ / ₁₆ | 1 ¹⁵ / ₁₆ | 5 ⁵ / ₈ | 1 ¹ / ₄ | 7 ⁷ / ₁₆ | 3/4 |
| 3/4" EP Branch Opposing-port Multiport Tee, 8 outlets | Q2387550 | 6 ¹ / ₁₆ | 1 ¹⁵ / ₁₆ | 5 ⁵ / ₈ | 1 ¹ / ₄ | 7 ⁷ / ₁₆ | 3/4 |

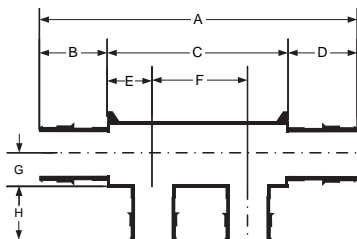

| EP flow-through multiport tees | | A | B | C | D | E | F | G | H |
|--------------------------------|----------|---------|--------|--------|--------|--------|-------|--------|--------|
| Description | Part no. | in | in | in | in | in | in | in | in |
| | | mm | mm | mm | mm | mm | mm | mm | mm |
| 2 outlets, 3/4" x 3/4" | Q2227557 | 4 3/8 | 1 5/16 | 2 1/2 | 1 5/16 | 5/8 | 1 1/4 | 7/16 | 3/4 |
| | | 112 | 24 | 64 | 24 | 16 | 32 | 11 | 19 |
| 3 outlets, 3/4" x 3/4" | Q2237557 | 5 11/16 | 1 5/16 | 3 3/4 | 1 5/16 | 5/8 | 1 1/4 | 7/16 | 3/4 |
| | | 143 | 24 | 95 | 24 | 16 | 32 | 11 | 19 |
| 3 outlets, 1" x 3/4" | Q2231057 | 6 3/16 | 1 9/16 | 4 1/16 | 1 5/16 | 3/4 | 1 1/4 | 9/16 | 3/4 |
| | | 157 | 30 | 103 | 24 | 19 | 32 | 14 | 19 |
| 3 outlets, 1 3/4" x 1 1/4" | Q2231373 | 8 3/16 | 1 7/16 | 5 5/16 | 1 7/16 | 7/8 | 1 3/4 | 5/8 | 1 |
| | | 208 | 37 | 135 | 37 | 23 | 44 | 17 | 25 |
| 3 outlets, 2" x 2" | Q2232102 | 10 5/8 | 2 3/16 | 6 1/4 | 2 3/16 | 1 1/8 | 2 | 1 5/16 | 1 5/16 |
| | | 269 | 56 | 158 | 56 | 28 | 51 | 24 | 33 |
| 4 outlets, 3/4" x 3/4" | Q2247557 | 7 13/16 | 1 5/16 | 5 7/8 | 1 5/16 | 1 1/16 | 1 1/2 | 7/16 | 3/4 |
| | | 198 | 24 | 150 | 24 | 18 | 38 | 11 | 19 |
| 4 outlets, 1" x 3/4" | Q2241057 | 7 7/8 | 1 3/16 | 5 | 1 5/16 | 5/8 | 1 1/4 | 9/16 | 3/4 |
| | | 180 | 30 | 127 | 24 | 16 | 32 | 14 | 19 |
| 4 outlets, 1" x 1" | Q2241051 | 7 11/16 | 1 3/16 | 5 5/16 | 1 3/16 | 3/4 | 1 1/4 | 9/16 | 3/4 |
| | | 195 | 30 | 135 | 30 | 19 | 32 | 14 | 19 |
| 6 outlets, 3/4" x 3/4" | Q2267557 | 9 3/8 | 1 5/16 | 7 1/2 | 1 5/16 | 5/8 | 1 1/4 | 7/16 | 3/4 |
| | | 239 | 24 | 191 | 24 | 16 | 32 | 11 | 19 |
| 6 outlets, 1" x 3/4" | Q2261057 | 9 5/8 | 1 3/16 | 7 1/2 | 1 5/16 | 5/8 | 1 1/4 | 9/16 | 3/4 |
| | | 244 | 30 | 191 | 24 | 16 | 32 | 14 | 19 |
| 6 outlets, 1" x 1" | Q2261051 | 9 7/8 | 1 3/16 | 7 1/2 | 1 3/16 | 5/8 | 1 1/4 | 9/16 | 3/4 |
| | | 251 | 30 | 191 | 30 | 16 | 32 | 14 | 19 |

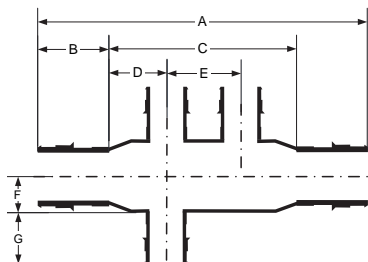

| EP flow-through opposing-port multipoint tees | | A | B | C | D | E | F | G |
|---|----------|---------------------------------|--------------------------------|-------|-----|-------|-----|-----|
| Description | Part no. | in | in | in | in | in | in | in |
| | | mm | mm | mm | mm | mm | mm | mm |
| 3 outlets, 3/4" x 3/4" | Q2337557 | 4 ⁷ / ₁₆ | 1 ⁵ / ₁₆ | 2 1/2 | 5/8 | 1 1/4 | 1/2 | 3/4 |
| | | 112 | 24 | 63 | 16 | 32 | 12 | 19 |
| 4 outlets, 3/4" x 3/4" | Q2347557 | 4 ⁷ / ₁₆ | 1 ⁵ / ₁₆ | 2 1/2 | 5/8 | 1 1/4 | 1/2 | 3/4 |
| | | 112 | 24 | 63 | 16 | 32 | 12 | 19 |
| 6 outlets, 3/4" x 3/4" | Q2367557 | 5 ¹¹ / ₁₆ | 1 ⁵ / ₁₆ | 3 3/4 | 5/8 | 1 1/4 | 1/2 | 3/4 |
| | | 144 | 24 | 95 | 16 | 32 | 12 | 19 |

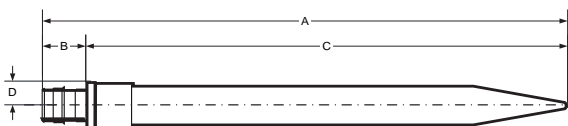

| ProPEX LF copper straight stubs | | A | B | C | D |
|--------------------------------------|-----------|----------------------------------|---------------------------------|----------------------------------|---------------------------------|
| Description | Part no. | in | in | in | in |
| | | mm | mm | mm | mm |
| 1/2" PEX LF Brass x 1/2" Copper, 8" | LF2935050 | 8 ⁵ / ₁₆ | 1 ¹ / ₁₆ | 7 ⁹ / ₁₆ | 3/8 |
| | | 211 | 18 | 193 | 10 |
| 1/2" PEX LF Brass x 1/2" Copper, 15" | LF2945050 | 14 ¹ / ₂ | 1 ¹ / ₁₆ | 13 ¹⁹ / ₁₆ | 3/8 |
| | | 368 | 18 | 350 | 10 |
| 2 1/2" PEX LF Brass x 2 1/2" Copper | LF2962525 | 12 ¹ / ₈ | 2 ¹⁹ / ₁₆ | 9 1/4 | 1 ¹³ / ₁₆ |
| | | 308 | 72 | 236 | 46 |
| 3" PEX LF Brass x 3" Copper | LF2963030 | 13 ¹¹ / ₁₆ | 3 ³ / ₈ | 10 ⁵ / ₁₆ | 2 ¹ / ₈ |
| | | 347 | 86 | 261 | 53 |

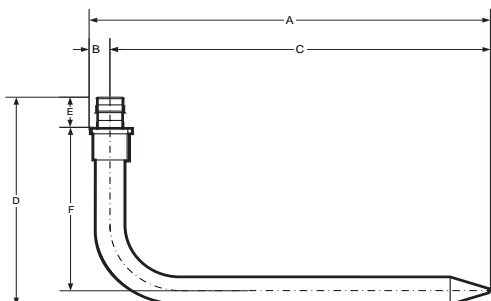

| ProPEX LF copper stub ells | | A | B | C | D | E | F |
|---|-----------|----------|--------|-----|---------|--------|---------|
| Description | Part no. | in | in | in | in | in | in |
| | | mm | mm | mm | mm | mm | mm |
| 1/2" PEX LF Brass x 1/2" Copper, 3 1/2" x 8" | LF2865050 | 8 3/8 | 3/8 | 8 | 4 3/4 | 1 1/16 | 3 3/4 |
| | | 213 | 10 | 203 | 121 | 18 | 95 |
| 1/2" PEX LF Brass x 1/2" Copper, 13" x 8" | LF2855050 | 8 3/8 | 3/8 | 8 | 13 5/16 | 1 1/16 | 12 5/16 |
| | | 213 | 10 | 203 | 338 | 18 | 312 |
| 1/2" PEX LF Brass x 1/2" Copper, 8" x 13" | LF2895050 | 13 3/8 | 3/8 | 13 | 13 5/16 | 1 1/16 | 7 5/16 |
| | | 340 | 10 | 330 | 338 | 18 | 185 |
| 3/4" PEX LF Brass x 3/4" Copper, 4" x 8" | LF2897575 | 8 9/16 | 9/16 | 8 | 5 7/16 | 1 5/16 | 4 1/16 |
| | | 217 | 14 | 203 | 138 | 24 | 103 |
| 1" PEX LF Brass x 1" Copper, 12" x 12" | LF2891010 | 13 11/16 | 1 1/16 | 13 | 16 | 1 3/16 | 14 1/4 |
| | | 347 | 17 | 330 | 406 | 30 | 362 |

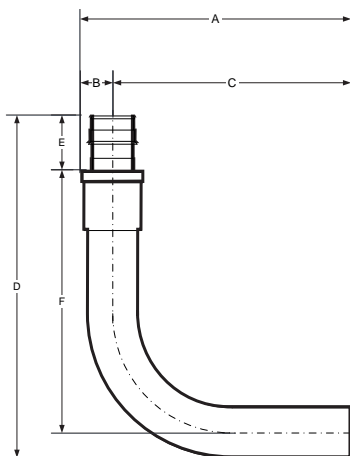

| ProPEX LF copper tub ells | | A | B | C | D | E | F |
|---|-----------|-------|-----|----|--------|--------|-------|
| Description | Part no. | in | in | in | in | in | in |
| | | mm | mm | mm | mm | mm | mm |
| 1/2" PEX LF Brass x 1/2" Copper, 3" x 6" | LF2875050 | 3 3/8 | 3/8 | 3 | 6 5/16 | 1 1/16 | 5 1/4 |
| | | 86 | 10 | 76 | 160 | 18 | 134 |
| 1/2" PEX LF Brass x 1/2" Copper, 3" x 4" | LF2885050 | 3 3/8 | 3/8 | 3 | 4 5/16 | 1 1/16 | 3 1/4 |
| | | 86 | 10 | 76 | 109 | 18 | 83 |

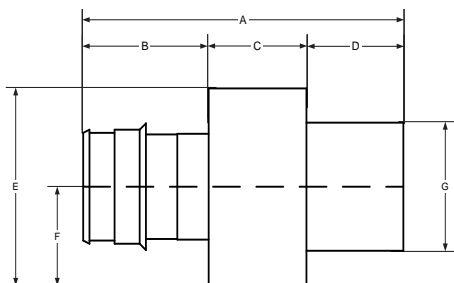

| ProPEX LF brass CPVC spigot adapters | | A | B | C | D | E | F | G |
|---|-----------|---------------------------------|---------------------------------|--------------------------------|--------------------------------|-------------------------------|--------------------------------|-------------------------------|
| Description | Part no. | in | in | in | in | in | in | in |
| | | mm | mm | mm | mm | mm | mm | mm |
| 1¼" PEX x 1¼" CPVC (CTS) | CP4501313 | 3 ¹¹ / ₁₆ | 1 ⁷ / ₁₆ | 1 ¹ / ₈ | 1 ¹ / ₈ | 2 ¹ / ₈ | 1 ¹ / ₁₆ | * |
| | | 94 | 37 | 29 | 29 | 54 | 27 | 35 |
| 1½" PEX x 1½" CPVC (CTS) | CP4501515 | 4 ³ / ₁₆ | 1 ¹¹ / ₁₆ | 1 ³ / ₁₆ | 1 ⁵ / ₁₆ | 2 ³ / ₈ | 1 ³ / ₁₆ | 1 ⁵ / ₈ |
| | | 107 | 43 | 30 | 34 | 61 | 30 | 41 |
| 2" PEX x 2" CPVC (CTS) | CP4502020 | 5 ³ / ₁₆ | 2 ³ / ₁₆ | 1 ⁷ / ₁₆ | 1¾ | 3 | 1½ | 2 ¹ / ₈ |
| | | 134 | 56 | 36 | 44 | 76 | 38 | 54 |

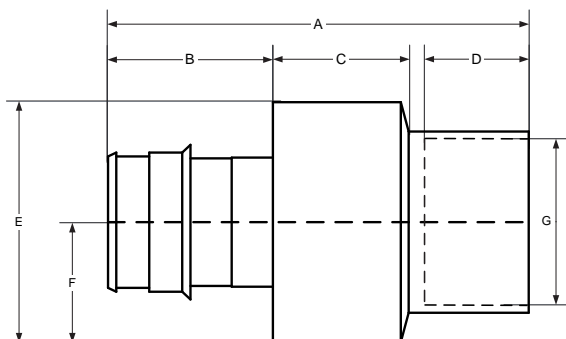

| ProPEX LF brass CPVC socket adapters | | A | B | C | D | E | F | G |
|---|-----------|---------------------------------|---------------------------------|-------------------------------|--------------------------------|-------------------------------|--------------------------------|-------------------------------|
| Description | Part no. | in | in | in | in | in | in | in |
| | | mm | mm | mm | mm | mm | mm | mm |
| 1¼" PEX x 1¼" CPVC (CTS) | CP4511313 | 3 ¹¹ / ₁₆ | 1 ⁷ / ₁₆ | 1¼ | 1 | 2 ⁵ / ₈ | 1 ¹ / ₁₆ | 1 ³ / ₈ |
| | | 94 | 37 | 32 | 26 | 54 | 27 | 35 |
| 1½" PEX x 1½" CPVC (CTS) | CP4511515 | 4 ³ / ₁₆ | 1 ¹¹ / ₁₆ | 1¼ | 1 ⁵ / ₁₆ | 2 ³ / ₈ | 1 ³ / ₁₆ | 1 ⁵ / ₈ |
| | | 106 | 43 | 32 | 33 | 61 | 30 | 42 |
| 2" PEX x 2" CPVC (CTS) | CP4512020 | 5 ³ / ₁₆ | 2 ³ / ₁₆ | 1 ³ / ₈ | 2 | 3 | 1½ | 2 ¹ / ₈ |
| | | 133 | 56 | 35 | 43 | 76 | 38 | 54 |

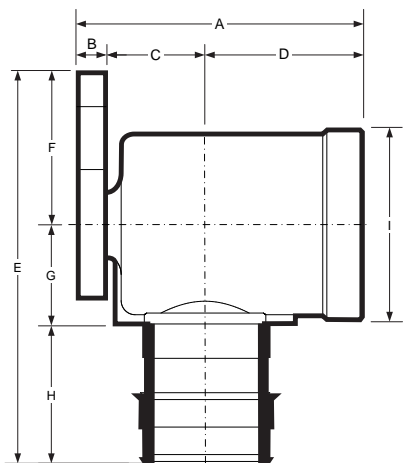

| ProPEX LF brass drop ear elbow | | A | B | C | D | E | F | G | H | I |
|--------------------------------|-----------|---------|-----|------|-------|--------|--------|--------|--------|--------|
| Description | Part no. | in | in | in | in | in | in | in | in | in |
| | | mm | mm | mm | mm | mm | mm | mm | mm | mm |
| 1/2" PEX x 1/2" FIP | LF4235050 | 1 11/16 | 1/4 | 7/16 | 1 | 2 3/16 | 1 | 9/16 | 11/16 | 1 1/16 |
| | | 43 | 6 | 11 | 26 | 56 | 26 | 14 | 18 | 26 |
| 3/4" PEX x 3/4" FIP | LF4237575 | 1 15/16 | 1/4 | 3/4 | 1 | 2 3/16 | 1 3/16 | 1 1/16 | 1 5/16 | 1 3/8 |
| | | 49 | 6 | 19 | 26 | 56 | 29 | 17 | 24 | 35 |
| 1" PEX x 3/4" FIP | LF4231010 | 2 7/16 | 1/4 | 7/8 | 1 1/4 | 3 5/16 | 1 5/16 | 7/8 | 1 3/16 | 1 5/8 |
| | | 62 | 6 | 22 | 32 | 84 | 33 | 22 | 30 | 42 |

Appendix D:

Uponor piping systems installation test questions

Please circle the correct answer below.

Section 1 – General installations

1. When making a ProPEX connection...

- a. Place the ProPEX ring on the pipe to the stop edge
- b. Make sure the head is installed and rotating properly
- c. Do not force the pipe onto the head when expanding
- d. Completely insert the fitting so the pipe/ring reach the fitting shoulder
- e. All of the above

2. Maintain a minimum distance between ProPEX fittings...

- a. To prevent damage to fittings
- b. To prevent damage to expander heads
- c. All of the above

3. When storing Uponor PEX piping...

- a. Keep in its original packaging
- b. Keep out of direct UV light
- c. All of the above

4. When making ProPEX-to-copper transitions...

- a. Maintain a minimum of 18" between solder/sweat and ProPEX connections
- b. Make solder/sweat connections prior to making ProPEX connections
- c. Use ProPEX copper press adapters for a flameless transition
- d. All of the above

5. Uponor's full 25-year warranty requires using Uponor PEX pipe with Uponor ProPEX rings and fittings.

- a. True
- b. False

Section 2 – Residential and in-suite installations

6. Per the IPC and UPC, support bare Uponor PEX piping...

- a. Every 32" (0.8m) horizontally for 1" and smaller pipe
- b. Every 48" (1.2m) for 1¼" and larger pipe
- c. Every 5 ft. (1.5m) vertically for all pipe sizes
- d. All of the above

7. When installing Uponor PEX systems, be sure to...

- a. Maintain a minimum distance of 12" (0.3m) from recessed light fixtures (unless insulated with suitable insulation)
- b. Maintain a minimum distance of 5 ft. (1.5m) from fluorescent lights (unless insulated with suitable insulation)
- c. Not use PEX between the tub/shower valve and tub spout
- d. All of the above

8. When installing Uponor PEX piping systems below grade...

- a. Use engineered polymer (EP) fittings approved for direct burial
- b. Cover brass fittings with a minimum 6-mil poly wrap
- c. Sleeve through concrete/masonry penetrations
- d. All of the above

9. When pressure testing Uponor PEX piping systems...

- a. Pressurize to 25 psi above working pressure or 100 psi
- b. Use a mixture of water and air
- c. Use air when allowed by local code
- d. All of the above

Section 3 – Commercial installations

10. PEX pipe must be protected when passing through steel framing.

- a. True
- b. False

11. What are the horizontal support requirements when using PEX-a Pipe Support?

- a. Maximum support distance is 8 ft. (2.4m) for all pipe sizes
- b. Support fittings 1½" and smaller within 12" (0.3m)
- c. Clamp the pipe at a maximum of 32 ft. (9.7m)
- d. All of the above

12. When installing PEX-a Pipe Support...

- a. Minimize cutting by using full lengths when possible
- b. Deburr sharp edges if cutting is required
- c. Strap according to **Figures 35-38** in this guide
- d. All of the above

13. To minimize expansion and contraction in systems with ΔT s greater than 40°F (22.2°C)...

- a. Support PEX with PEX-a Pipe Support and included straps
- b. Clamp the pipe at a maximum 32 ft. (9.7m) on center
- c. Use fixed points according to length of run and pipe size
- d. All of the above

14. When installing Uponor PEX piping for vertical riser applications...

- a. Support at the base of each floor with a CTS riser clamp
- b. Support every 5 ft. (1.5m)
- c. Clamp at the top of the floors according to system type (e.g., domestic hot water, heating hot water, etc.)
- d. All of the above

15. When pressure testing large-volume commercial PEX systems...

- a. Fill system with potable water, air or a combination of both
- b. Condition the pipe to 1.5 times the test pressure or 120 psi (8.2 bar) for 30 minutes
- c. After 30 minutes, release excess pressure until you reach desired test pressure [80 psi (5.5 bar) recommended]
- d. Monitor system for leaks over the required time period
- e. All of the above

Uponor, Inc.

5925 148th Street West
Apple Valley, MN 55124
USA

T 800.321.4739

F 952.891.2008

Uponor, Ltd.

6510 Kennedy Road
Mississauga, ON L5T 2X4
CANADA

T 888.994.7726

F 800.638.9517

uponor

uponorpro.com