

# V-SERIES

**FOR USE WITH MODELS  
V-200**



## APPLICATION

Condensing wall-hung boilers, tankless hot water heaters, or furnaces.

## INTRODUCTION

**WARNING** Please follow these installation instructions carefully in order to avoid a safety hazard, severe injury, death, and/or substantial property damage.

- The neutralizer should only be installed and serviced by a qualified installer/service technician. Failure to follow these instructions completely can cause a safety hazard, severe personal injury, or substantial property damage
- All JJM® neutralizers use our proprietary pH Power Pellets®, which can only be found in JJM® products.

**WARNING** Only pH Power Pellets® can be used in JJM® neutralizers. Any other media, such as limestone or marble chips, is strictly prohibited. Failure to follow these instructions completely voids the manufacturer's limited warranty and could cause a safety hazard, severe personal injury, or substantial property damage. For information on pH Power Pellets®, including Safety Data Sheet, visit [www.jjmalkalinetech.com](http://www.jjmalkalinetech.com).

**NOTE** - Always consult the local authority regarding any requirements concerning flue gas condensate handling codes.

## PREPARE FOR INSTALLATION

- The neutralizer must be located at a lower elevation than the condensate drain on the appliance to ensure proper flow of condensate through the drain line. Relocate and elevate the appliance above the neutralizer, if necessary. This neutralizer should be wall-mounted below the appliance.
- Prepare to route the neutralizer outlet piping to an appropriate drain. If a drain is not located within close proximity, use a condensate pump to route condensate to a suitable location.

**WARNING** Do not exhaust flue gases through the neutralizer. Flue gas leakage or venting exhaust through the neutralizer could cause injury or death from carbon monoxide.

## INSTALLATION

- Turn off electrical power and main manual gas shutoff to the appliance.
  - Prepare to mount the neutralizer in a vertical position. Remove end-cap and affix the built-in mounting bracket to the wall, making sure not to damage any appliance components.
- RECOMMENDED** - Install a vacuum breaker before the neutralizer inlet that is open to atmosphere above the neutralizer inlet.
- Fill the canister with pH Power Pellets® (included) around the green inner tube.
  - Secure the canister into the end-cap and quarter turn until the canister locks .
  - Connect vinyl tubing or PVC piping from the appliance condensate trap outlet to the neutralizer inlet. Fittings kit included.
  - Connect the neutralizer outlet to the drain (or condensate pump, if applicable). Access to the condensate discharge is necessary for proper maintenance to check the efficacy of the pH Power Pellets® media.

- Secure the drain piping using clamps to prevent movement, as appropriate.
- Use Teflon tape on all threaded plastic fittings, as appropriate, and only use appropriate corrosion-resistant materials.
- Connections to the appliance and neutralizer must be installed to ensure that no condensate back flow can occur.
- Before operating the appliance, fill the neutralizer and traps with tap water to establish flow. Never operate with dry neutralizer or P-traps.
- Turn on electrical power and gas to the appliance and restore the appliance to normal operation. Verify condensate drains properly and test the pH level at the outlet of the neutralizer.

**NOTE** - Do not route the condensate line through any area that is exposed to freezing temperatures. If personnel traffic poses a risk, install protection to prevent movement and/or damage.

**OPERATION**

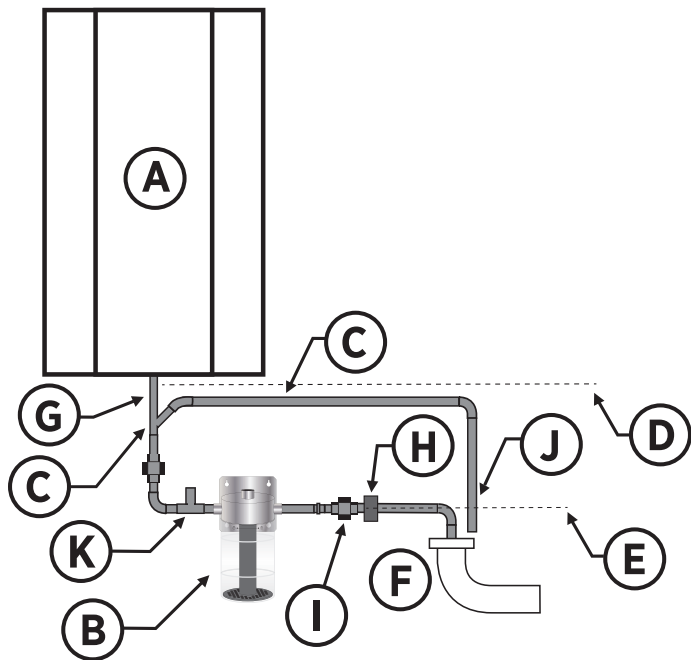

- A. Condensing Appliance
- B. Neutralizer (wall mounted)
- C. Optional Y-fitting for an overflow drain line placed below the bottom of the condensate drain line
- D. Bottom of the condensate outlet from the appliance **MUST** be ABOVE the bottom of the neutralizer outlet
- E. Bottom of the neutralizer condensate outlet
- F. Route discharge to floor drain or to an appropriate drain location
- G. PVC pipe—Include unions on the drain line to allow removal of the unit for inspection and service. Secure pipe in place—protect with a shield if necessary if routed through traffic areas
- H. Secure condensate piping in place with clamps if necessary (follow instructions for mounting of condensate pump, when used)
- I. Install a union at each connection to the neutralizer to allow for removal and servicing as needed
- J. Terminate the overflow line above the drain location so any flow from the line is easily visible
- K. Optional vacuum breaker tee before the neutralizer inlet

**MAINTENANCE**

- The neutralizer should be serviced regularly, including visual inspection for leaks or damage and replacement of the pH Power Pellets®.
- pH Power Pellets® must be replaced the sooner of (i) annually, or (ii) the pH level at the outlet of the neutralizer drops below 5.0 (or the minimum level of the local water authority).
- The pH level can be monitored by taking a sample from the outlet of the neutralizer using a suitable pH test strip or an electronic pH meter for precise measurements.
- For refills of pH Power Pellets®, contact your local JJM® distributor, a list can be found at [www.jjmalkalinetech.com](http://www.jjmalkalinetech.com).

**LIMITED WARRANTY**

The neutralizer is warranted against defects in materials and workmanship for one year. The warranty does not cover issues that result from misuse, improper installation, and/or failure to replace the pH Power Pellets® as instructed.

**V-200 INCLUDED PARTS & DIMENSIONS**

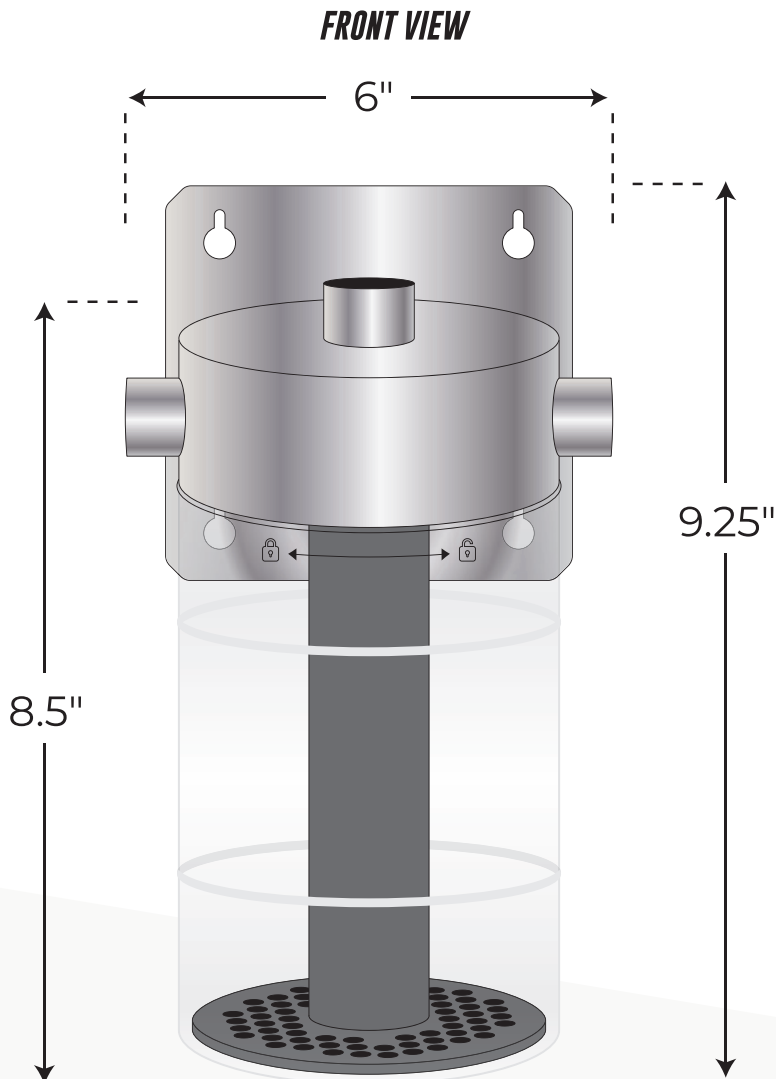

**V-200 INCLUDED PARTS**

- (1) O-ring
- (2) 3/4" Socket Adapter
- (2) 3/4" Barb Fitting
- (1) Plug