



428 Jones Boulevard Phone: (610)495-5131
 Limerick Airport Business Center Fax: (610)495-5134
 Pottstown, PA 19464 www.watsonmcdaniel.com

IB SERIES 1031-1032, 1033-1034 1041-1042, 1044, 1031S, 1038S INVERTED BUCKET STEAM TRAP INSTALLATION INSTRUCTIONS.

INSTRUCTION PART NO. 2230200 REVISION 2

INSTALLATION

Before installing the Watson McDaniel Inverted Bucket Steam Trap, blow down the piping that leads to the trap's inlet. Use full line pressure to remove all scale, chips, debris, etc. Be sure the trap differential pressure rating is adequate for the installation. The maximum pressure differential (the difference between the trap's inlet and outlet pressures) the trap will open against is stamped on the trap cover.

Install the trap in a horizontal pipeline with the inlet below the liquid level of the equipment being drained and in a location easily accessible for inspection and maintenance. A sketch of a recommended hookup arrangement is shown below. Use pipe dope or teflon tape on pipe joints. Make inlet piping as short as possible with a minimum of elbows and other restrictions. Install a dirt leg in the line ahead of the trap. To allow for maintenance, install a valve on each side of the trap and a strainer ahead of the trap inlet. All valves should be of the full ported type to avoid restricted flow.

If the discharge piping is to be elevated, be sure that the differential pressure is adequate to overcome this lift. Install a check valve (optional) in the discharge piping near trap to prevent backflow when the system is not operational.

NOTE: Trap must be primed (filled with water) before start up. Without priming trap will not operate. This style trap is not recommended for superheated steam service, as the prime may be lost to the excessive heat.

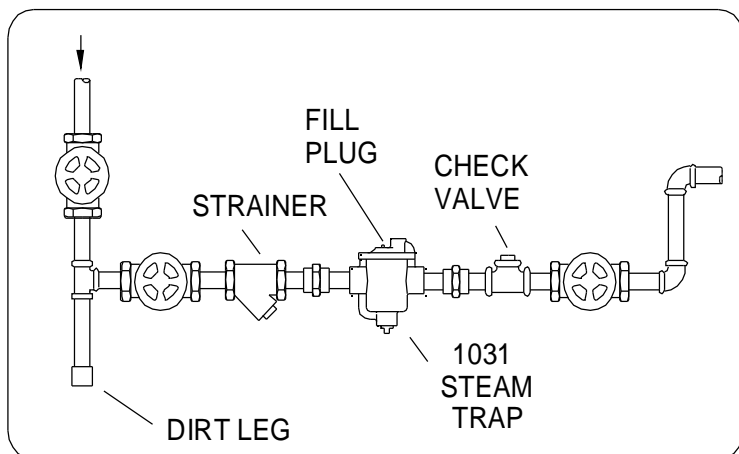
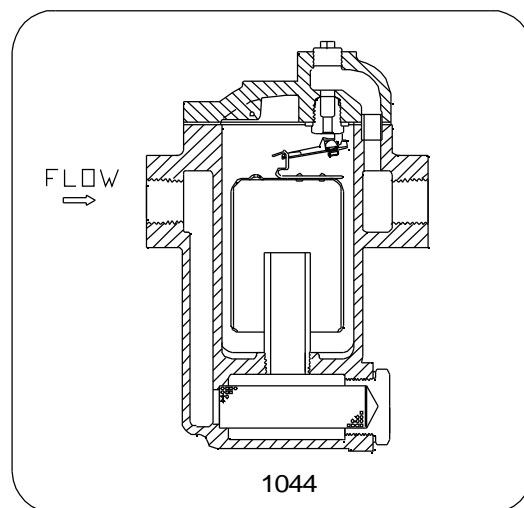
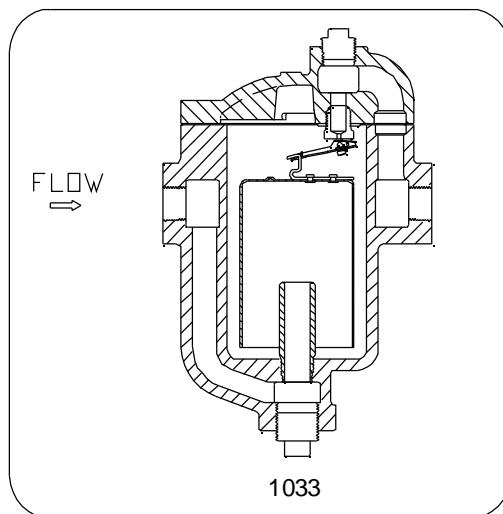
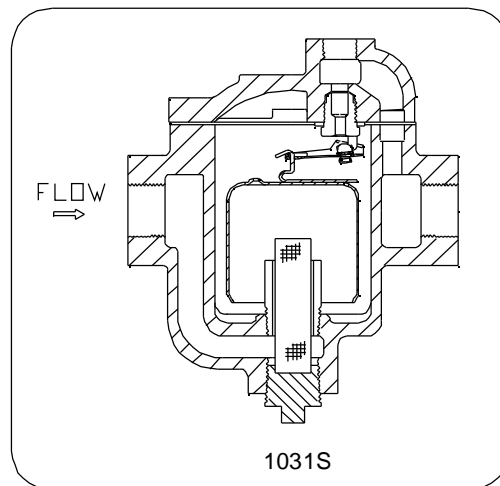

RECOMMENDED INSTALLATION

PMO	250 PSIG*	PMA	250 PSIG up to 450°F
TMO	450°F	TMA	450°F @ 250 PSIG

Each Watson McDaniel Company Product is warranted against defects in material and workmanship for one year from date of shipment. This warranty extends to the first retail purchaser only. All defective material must be returned to the person from whom you purchased the Product, transportation prepaid, free of any liens or encumbrances, and if found to be defective will be repaired free of charge or replaced, at the warrantor's or seller's option. If the material is replaced, any replacement will be invoiced in the usual manner and after inspection of alleged defective material an adjustment will be made for depreciation caused by purchaser's use. In no event will Watson McDaniel Company be liable to do more than refund the original contract price. Incidental and consequential damages are excluded, whether under this warranty or otherwise. All implied warranties, including warranties of merchantability and fitness for a particular purpose, are disclaimed and excluded.

HOW IT WORKS

Having only two moving parts, the valve lever assembly and bucket, these traps will not stick, bind, or clog, since they do not have fixed pivots or complicated linkages. They operate on the difference in density between steam and water. During start-up, the trap is open, air and gases vent slowly out the top of the bucket through the vent hole. Condensate entering through the feed tube forms a water seal on the bottom of the bucket, turning it into a float. When all the condensate has been discharged, the steam enters to fill the bucket, which then snaps up closing the trap. The bucket would normally stay in this position, however when the steam condenses, more condensate enters the trap pushing the gases out through the vent hole causing the bucket to be completely submerged in condensate. Loosing its buoyancy, the bucket (its weight being greater than the weight of the water) falls, opening the trap.

PRIMING THE TRAP

There are two basic ways of priming an Inverted Bucket Trap. The simplest way is fill the trap with water before installation.

The other way to prime a trap is after the trap has been installed in line, close the isolation valve upstream from the trap for a few minutes so that the steam would condense during the dead head, and then slowly open the isolation valve so that the condensate would fill up the trap.

Without priming, the Inverted Bucket trap will not operate.

MAINTENANCE

Isolate trap from both supply and return lines.

Wait until trap can be comfortably touched by hand before removing cover.

Remove cover and discard gasket.

Unhook bucket from lever.

Inspect lever and seat assembly for dirt and wear. If worn install a new repair kit. If dirty, clean using method compatible with system.

Reinstall cover and bucket assembly using a new gasket.

Torque cover bolts and reactivate supply and return lines.

ORDERING SPARE PARTS

Specify the description of the part. Indicate the trap Series number and differential pressure which is stamped on the cover. Also indicate adjacent Part No.

Typical Specification: Series 1031 lever and seat assembly for 20 psig differential pressure. Part No. 5-9.

MATERIALS

Body & Cover Cast Iron, ASTM A-278 Class 30
 Nuts & Bolts High-tensile Steel
 Gasket Non-Asbestos Fiber
 Bucket Stainless Steel
 Lever & Seat Ass'y. Stainless Steel
 Valve & Sea. Heat Treated Stainless Steel
 *Strainer Stainless Steel
 *1031S, 1038S, 1041, 1042, 1044 only

REPAIR KITS

1031/1041 REPAIR PARTS CONSIST OF:

SCREEN Part No. 9-1
 GASKET Part No. 3-7
 BUCKET and CLIP Part No. 4-6
 ** LEVER and SEAT ASSEMBLY . .Part No. 5-9

1032/1042 REPAIR PARTS CONSIST OF:

SCREENPart No. 9-2
 GASKET Part No. 3-7
 BUCKET and CLIP Part No. 4-7
 ** LEVER and SEAT ASSEMBLY . .Part No. 5-10

1034/1044 REPAIR PARTS CONSIST OF:

SCREENPart No. 9-3
 GASKET Part No. 3-8
 BUCKET and CLIP Part No. 4-8
 ** LEVER and SEAT ASSEMBLY . .Part No. 5-11

1033 REPAIR PARTS CONSIST OF:

GASKET Part No. 3-12
 BUCKET and CLIP Part No. 4-14
 ** LEVER and SEAT ASSEMBLY . .Part No. 5-15

1038S REPAIR PARTS CONSIST OF:

GASKET Part No. 3-9
 BUCKET and CLIP Part No. 4-9
 ** LEVER and SEAT ASSEMBLY . Part No. 5-12
 SCREEN Part No. 9-3S

** SPECIFY MAXIMUM OPERATING INLET PRESSURE WHEN ORDERING.