

## Single stage operation oil burner

**WARNING**

### **NON-RETROFIT APPLICATIONS**

*If this burner is being installed in a packaged unit (ie. burner comes with a boiler or furnace), follow the installation and set-up instructions supplied with the heating unit, as settings may differ from those shown in this manual.*

- *The following pages contain information, descriptions and diagrams for the proper installation and wiring of the burner. Please read carefully before attempting final installation.*
- *This manual is to remain with the final installation designation. It is the installer's responsibility to ensure that the burner installation and operation instructions mentioned in this manual are followed and operated within local code authority limits.*

**RIELLO 40**

CODE	MODEL	TYPE
3726413	F15 WITH MANUAL AIR SHUTTER	264T



## INSTALLATION PRECAUTIONS

### AIR FOR COMBUSTION

Do not install burner in room with insufficient air for combustion. Be sure there is an adequate air supply for combustion if the boiler/furnace room is enclosed. It may be necessary to create a window to permit sufficient air to enter the boiler/furnace room. The installer must follow local ordinances in this regard.

**CANADA** It is suggested that the installer follow CSA standard B139.

**USA** It is suggested that the installer follow NFPA manual #31.

### CHIMNEY

Be sure chimney is sufficient to handle the exhaust gases. It is recommended that only the burner be connected to the chimney. Be sure that it is clean and clear of obstructions.

### OIL FILTER

An external oil filter is **REQUIRED**, even though there is an internal strainer in the pump. The filter should be replaced at least once a year, and the filter container should be thoroughly cleaned prior to installing a new filter cartridge.

### DRAFT

Follow the instructions furnished with the heating appliance. The pressure in the combustion area should be kept as close to zero as possible. The burner will operate with a slight draft or pressure in the chamber.

### ELECTRICAL CONNECTIONS

**CANADA** All electrical connections should be done in accordance with the C.E.C. Part 1, and all local codes. The system should be grounded.

**USA** All electrical connections should be done in accordance with the National Electrical Code, and all local ordinances. The system should be grounded.

### CONTROL BURNER OPERATION

Check out the burner and explain its operation to the homeowner. Be sure to leave the Owner's Instruction sheet with the homeowner.

### FIRE EXTINGUISHER

If required by local codes, install an approved fire extinguisher.

### ELECTRICAL CONNECTIONS

In most localities, a number 14 wire should be used inside a metal conduit. The system should be grounded. A service switch should be placed close to the burner on a fireproof wall in an easily accessible location.

---

## TABLE OF CONTENTS

PACKAGE CONTENTS LIST . . . . .	1
SERIAL NUMBER IDENTIFICATION . . . . .	1
TECHNICAL DATA . . . . .	2
Specifications . . . . .	2
Burner and mounting flange dimensions . . . . .	2
Burner components identification . . . . .	2
Burner components . . . . .	2
INITIAL SET-UP . . . . .	3
ASSEMBLY OF AIR TUBE TO BURNER CHASSIS . . . . .	3
MOUNTING BURNER TO BOILER OR FURNACE . . . . .	3
Method 1-Universal Mounting Flange . . . . .	3
Method 2-Semi-flange Collar . . . . .	4
Method 3-Pedestal Mount . . . . .	4
ELECTRICAL CONNECTIONS . . . . .	5
APPLICATION FIELD WIRING . . . . .	5
NOZZLE PLACEMENT . . . . .	6
INSERTION / REMOVAL OF DRAWER ASSEMBLY . . . . .	6
ELECTRODE SETTING . . . . .	6
TURBULATOR SETTING . . . . .	6
OIL LINE CONNECTIONS . . . . .	7
Single line (Gravity feed system) . . . . .	8
Two line (Lift system) . . . . .	8
PUMP PURGE . . . . .	9
Single line (Gravity feed system) . . . . .	9
Two line (Lift system) . . . . .	9
SETTING THE AIR ADJUSTMENT PLATE . . . . .	10
BURNER SET-UP CHART . . . . .	10
DUCTED COMBUSTION AIR INTAKE APPLICATIONS . . . . .	11
BURNER START-UP CYCLE . . . . .	12
EXPLODED SPARE PARTS LIST . . . . .	13
SPARE PARTS LIST . . . . .	14
BURNER START-UP REPORT . . . . .	15

## PACKAGE CONTENTS LIST

Your Riello 40 burner should include the following parts. Please check to make sure all parts are present before beginning the installation.

Quantity	Description	Code
1	Burner chassis with cover	3726413
1	Universal mounting flange + mounting gasket	2567395
1	Parts bag	2566282
1	Parts bag	2567338
1	Installation manual	2902555
1	By-pass plug	
1	<b>Separate carton</b> - OEM burners shipped with combustion head mounted	
1	Air Tube/Drawer Assembly	

### Parts bag 2566282

Quantity	Description
1	Female 1/4" NPT adapter
1	Male 3/8" NPT adapter
1	Oil pump connector (supply)
1	Oil pump connector (return)
2	Mounting flange bolts (short)
2	Nuts
2	Chrome nuts

### Parts bag 2567338

Quantity	Description
2	Semi-flange bolts (long)
2	Semi-flange
2	Cover screws
2	Nuts

## SERIAL NUMBER IDENTIFICATION

Your Riello burner may have been manufactured in more than one location and therefore there are two possible serial number identification.

The Riello 9 character serial number, example,

**06 01 12345**, is identified as follows:

- 06** = Last two digits of the year of manufacture;
- 01** = Week of manufacture;
- 12345** = Increment of 1 for each burner produced – specific to product code – reset to zero each January 1<sup>st</sup>.

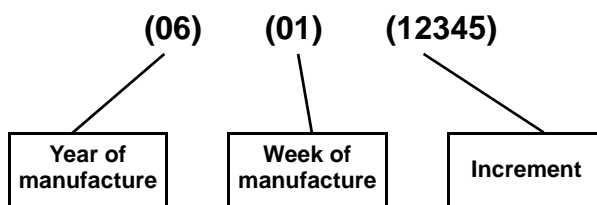

The Riello 15 character serial number, example,

**06 A 8511111 00025**, is identified as follows:

- 06** = Last two digits of the year of manufacture;
- A** = BI-week of manufacture;
- 8511111** = Burner product code;
- 00025** = Increment of 1 for each burner produced – specific to product code – reset to zero each January 1<sup>st</sup>.

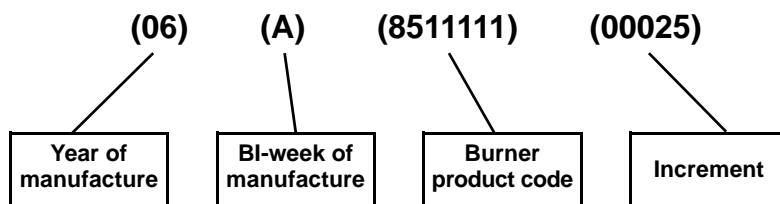

## TECHNICAL DATA SPECIFICATIONS

Fuel	No. 2 Fuel Oil
Firing rate	2.55 to 5.75 GPH 8.2 to 18.6 kg/h
Effective output	357,000 to 805,000 BTU/h - 104.6 to 235.8 kW 89,960 to 202,860 kcal/h
Voltage (single phase)	120V 60Hz (+ 10% - 15%)
Absorbed electrical power	450 Watts
Motor (rated)	3250 rpm Run Current 4 AMP
Capacitor	16 Microfarads 260V
Pump pressure	100 to 200 psi
Primary control	RIELLO 530 SE/C 24V
Ignition transformer	8kV 16mA

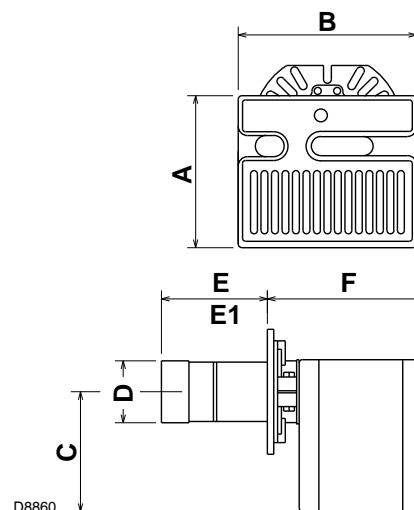

## BURNER AND MOUNTING FLANGE DIMENSIONS

Model F15	A	B	C	D	E	F	G	H	I	L
Inches	11 3/4	13 25/32	9 1/16	4 11/16	5	11 27/32	1 1/2	1/4	7/16	2 7/8
mm	298	350	230	119	127	301	38	6	11	73

E1: 10-inch long (254mm) tubes are also available.

## BURNER COMPONENTS IDENTIFICATION

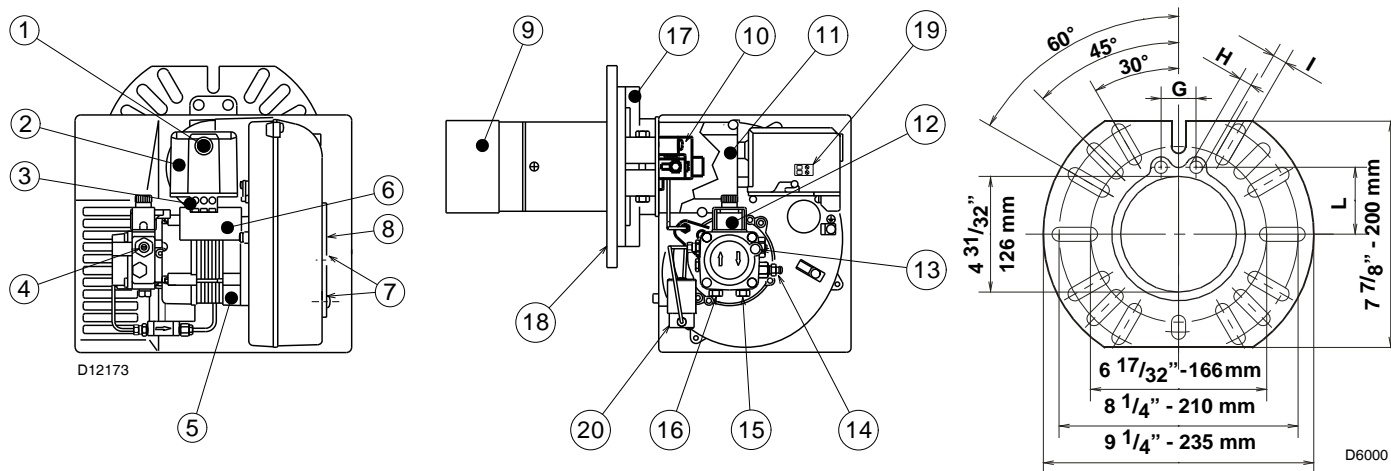

## BURNER COMPONENTS

- |  |                                    |
|--|------------------------------------|
| 1 Lockout indicator lamp and Reset button  | 12 Coil                            |
| 2 Primary control                          | 13 Vacuum gauge connection port    |
| 3 Primary control sub-base                 | 14 Pressure gauge and bleeder port |
| 4 Pump pressure regulator adjustment screw | 15 Return fuel line port           |
| 5 Motor                                    | 16 Supply fuel line port           |
| 6 Capacitor                                | 17 Adjustable collar               |
| 7 Air adjustment fixing screws             | 18 Mounting flange with gasket     |
| 8 Air shutter                              | 19 24V thermostat connections      |
| 9 End cone                                 | 20 Solenoid valve                  |
| 10 Turbulator adjustment screw             |                                    |
| 11 Air tube cover                          |                                    |

**INITIAL SET-UP**

- A) Remove burner and air tube from cartons. Check parts list (inside cover) to ensure all parts are present.
- B) Remove burner cover by loosening the three screws securing it. Remove control box and air tube cover.
- C) Remove drawer assembly from air tube, insert nozzle and set Turbulator adjustment for specific input required, then set aside.
- D) Mount air tube to burner chassis.

**ASSEMBLY OF AIR TUBE TO BURNER CHASSIS**

The air tube and drawer assembly are shipped in a carton separate from the burner chassis. Choose the proper air tube length to obtain the tube insertion for the specific installation.

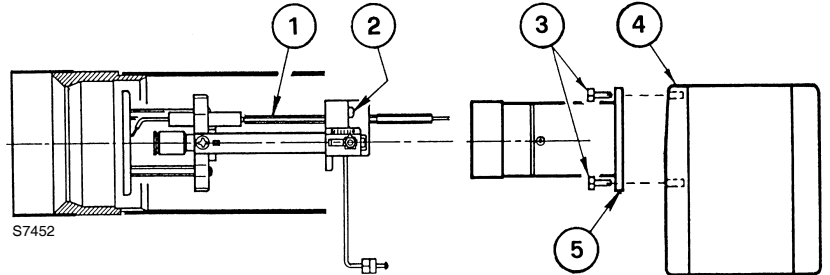

- A) Remove the AIR TUBE and BURNER CHASSIS from their respective cartons.
- B) Remove the DRAWER ASSEMBLY (1) from inside the AIR TUBE by loosening the screw (2). Carefully pull the DRAWER ASSEMBLY out of the AIR TUBE, instal the required nozzle (see page 7) and set aside.
- C) Remove the two BOLTS (3) from FRONT PLATE (4) of the BURNER CHASSIS. Align the two holes on the AIR TUBE HOLDING PLATE (5) with the two holes left open on the BURNER CHASSIS FRONT PLATE when the BOLTS (3) were removed. Replace the BOLTS and finger tighten only. Re-install DRAWER ASSEMBLY into AIR TUBE. Tighten SCREW (2) securely.
- D) Tighten the two bolts (3) securely.

**MOUNTING THE BURNER TO THE BOILER OR FURNACE**

There are three possible methods to mount the burner, depending on the individual application. These are:

- 1) Universal flange bolted to Boiler/Furnace unit.
- 2) Semi-flange collar bolted to Boiler/Furnace unit.
- 3) Universal flange mounted to optional Pedestal mount, where flange mounting direct to appliance is not possible. Pedestal kit must be ordered separately.

**METHOD 1 – UNIVERSAL MOUNTING FLANGE**

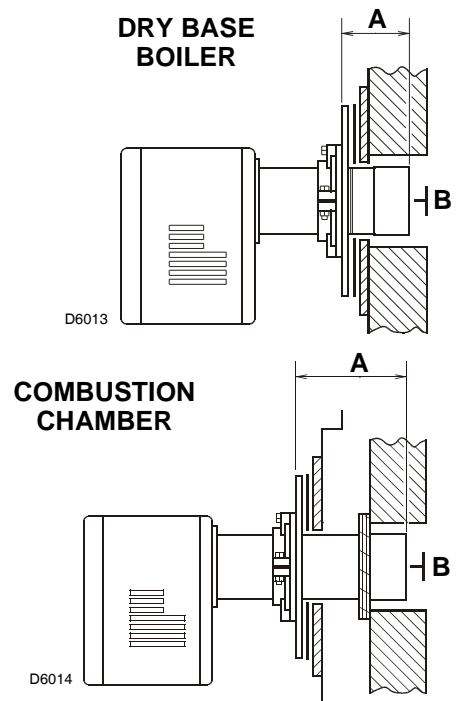
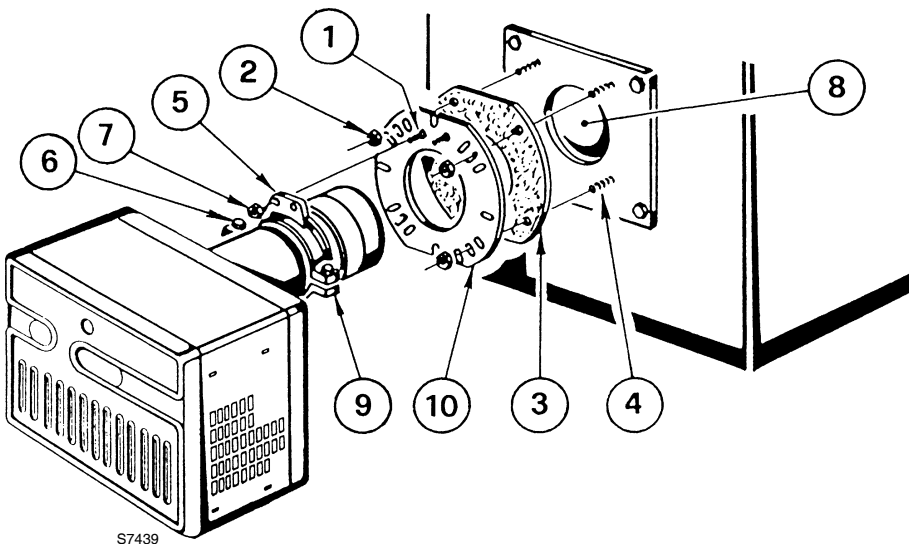

- A) Insert the two BOLTS (1) into the UNIVERSAL MOUNTING FLANGE (10) from the flat side, ensuring the bolt heads are flush with the flat surface. Secure in place using two special CHROME NUTS (2) provided.
- B) Position the MOUNTING GASKET (3) between the flat surface of the UNIVERSAL MOUNTING FLANGE (10) and the appliance. Line up the holes in the UNIVERSAL MOUNTING FLANGE with the STUDS (4) on the appliance mounting plate and securely bolt the UNIVERSAL MOUNTING FLANGE to the plate.
- C) Secure the two semi-flanges of the ADJUSTABLE COLLAR (9) to the AIR TUBE using the two long BOLTS (6). Be sure that the ADJUSTABLE collar is properly positioned so the outside edge of the END CONE will be at least 1/4 inch (6.5 mm) back from the inside wall of the refractory of the combustion chamber (see dimension **B** at right). The measured length (**A**), is to include MOUNTING GASKET and FLANGE, if used.
- D) The burner may now be attached to the heating unit by inserting the AIR TUBE through the BURNER ACCESS HOLE (8) and into the appliance, making sure the BOLTS (1) line up with the two HOLES (5) in the ADJUSTABLE COLLAR. Secure the burner in place using two NUTS (7).
- A visual verification of the air tube insertion into the combustion chamber of the heating unit is suggested. Dimension B should be at least 1/4" (see drawing).

**NOTE:**

A suggested method for creating mounting bolt holes in the mounting gasket: Hold the gasket against the appliance mounting bolts using the mounting flange for proper positioning. Lightly tap the flange with a hammer to form the holes.

**METHOD 2 – SEMI-FLANGE COLLAR**

- A) Follow item C from METHOD 1.
- B) Align the air tube and attached adjustable collar so air tube is centered in the burner access hole of the boiler/furnace unit.  
Mark the center of the two holes in the ADJUSTABLE COLLAR on to the front plate of the heating unit.  
Then drill 1/4 inch (6.5 mm) holes through the front plate of the unit, using marks as a guide.
- C) Install two short BOLTS (1) through the front plate of the heating unit from the inside, and secure on the outside using the two special CHROME NUTS (2).
- D) Follow item D from METHOD 1.

**METHOD 3 – PEDESTAL MOUNT**

Secure the MOUNTING FLANGE to MOUNTING PEDESTAL using the hardware provided with the pedestal. Secure burner to MOUNTING FLANGE as in METHOD 1, item A, C and D.

**NOTE:**

It is suggested that the pedestal be anchored in position on the floor by installing brackets over the pedestal tube and securing brackets to the floor.



**WHEN THE COMBUSTION CHAMBER IS LINED WITH A REFRACTORY MATERIAL, IT IS IMPERATIVE THAT THE END CONE NOT PROTRUDE INTO THE CHAMBER AREA, AS EXCESSIVE HEAT AT BURNER SHUT DOWN WILL DAMAGE THE END CONE.**

## ELECTRICAL CONNECTIONS

It is advisable to leave the control box off the sub-base while completing the electrical connection to the burner.

- 1) Wire access hole (Use BX electrical connector)
- 2) Earth ground conductor terminal (Green wire)
- 3) Hot conductor terminal (Black wire)
- 4) Neutral conductor terminal (White wire)
- 5) Strain relief clamp

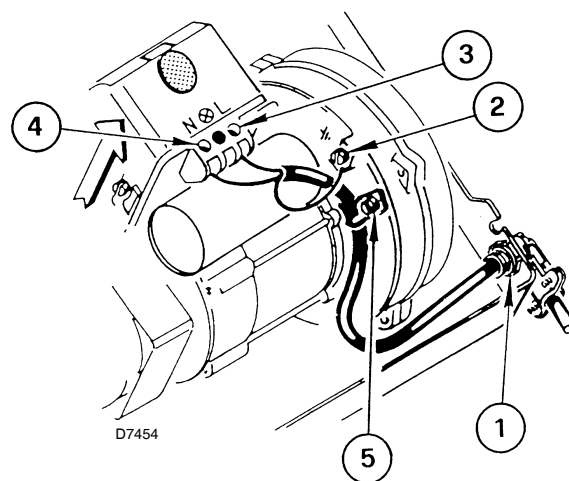

**WARNING:**

The hot (black) wire must be connected to the L terminal and the neutral (white) wire must be connected to the N terminal or the primary safety will be damaged.  
Do not connect wither wire to the terminal marked ⊗.

The burner may be controlled using either a DIRECT LINE VOLT-AGE control circuit (120V AC 60 cycle) OR:

- a LOW VOLTAGE thermal input (T-T) if the primary control 530SE/C 24V is used;

Using the appropriate diagram below, make electrical connections to burner. All wiring must be done in accordance with existing electrical codes, both national and local.

When all electrical connections have been made, the control box may be put back in place on the sub-base.

**WARNING: DO NOT** activate burner until proper oil line connections have been made, or failure of the pump shaft seal may occur.

**DIRECT LINE VOLTAGE**

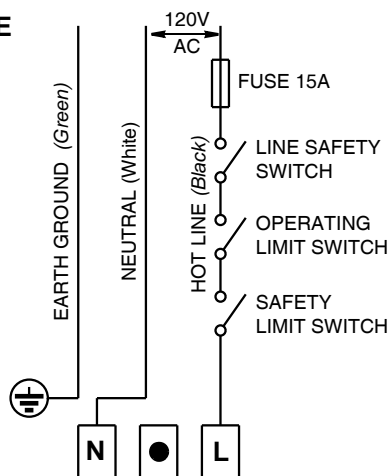

**LOW VOLTAGE**

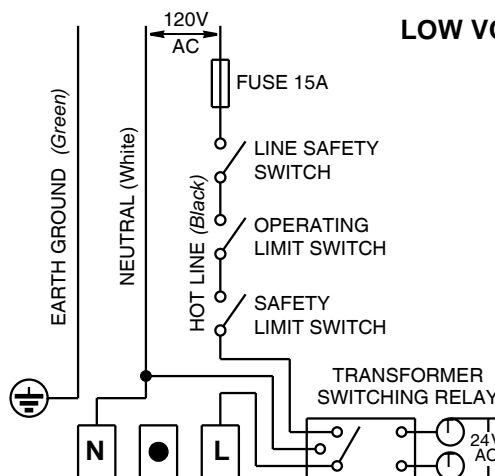

**FACTORY WIRED SUB-BASE**

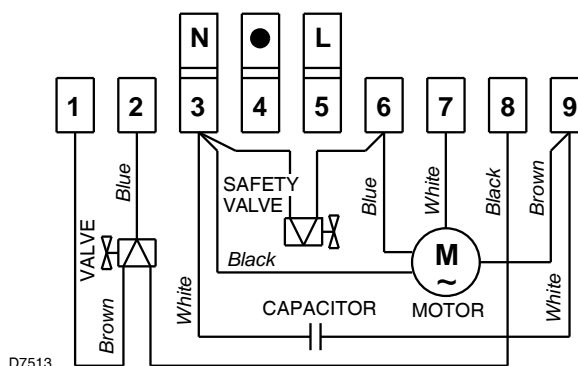

**NOTE:** Terminal 4 is to be used to activate a remote safety lockout circuit only. A 120V AC source is supplied to Terminal 4 upon lockout. The maximum allowable current draw for this circuit is 1 AMP.

**IMPORTANT:** if a neutral or ground lead is attached to Terminal 4, the control box will be damaged should lockout occur.



## NOZZLE PLACEMENT

- Determine the proper firing rate for the boiler or furnace unit, considering the specific application, then use the Burner Set-up chart to select the proper nozzle and pump pressure to obtain the required input from the burner.
- Remove the NOZZLE ADAPTER (2) from the DRAWER ASSEMBLY by loosening the SCREW (1).
- Insert the proper NOZZLE into the NOZZLE ADAPTER and tighten securely (Do not overtighten).
- Replace adapter, with nozzle installed, into drawer assembly and secure with screw (1).

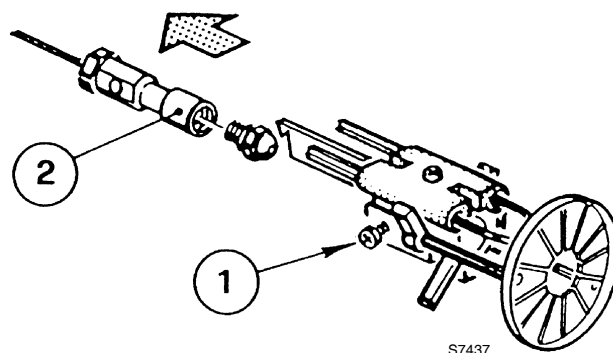

## INSTALLATION/REMOVAL OF DRAWER ASSEMBLY

- To remove drawer assembly, loosen SCREW (3), then unplug CONTROL BOX (1) by carefully pulling it back and then up.
- Remove the AIR TUBE COVER PLATE (5) by loosening the two retaining SCREWS (4).
- Loosen SCREW (2), then slide the complete drawer assembly out of the combustion head as shown.
- To insert drawer assembly, reverse the procedure in items A to C above, then attach fuel line to the pump.

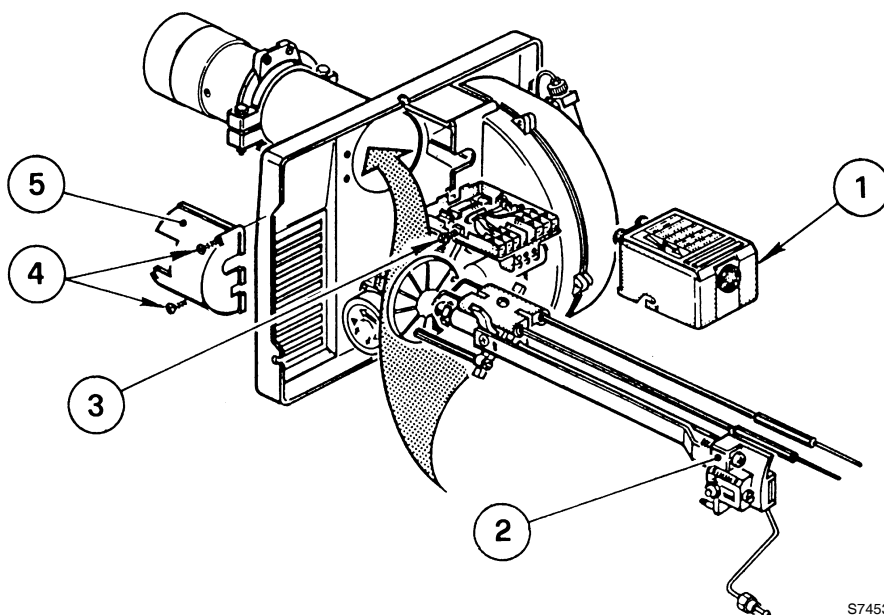

## ELECTRODE SETTING

### IMPORTANT:

These dimensions must be observed and verified.

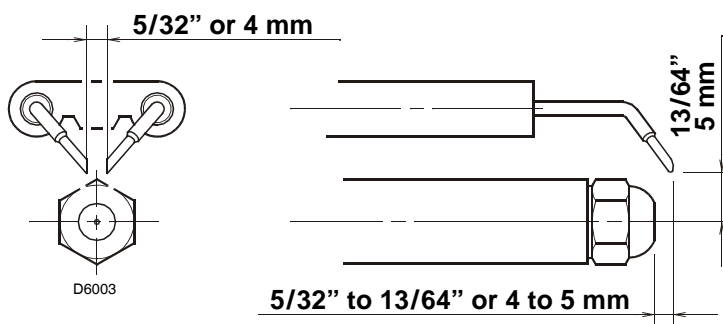

## TURBULATOR SETTING

- Loosen NUT (1), then turn SCREW (2) until the INDEX MARKER (3) is aligned with the correct index number as per the Burner Set-up chart.
- Retighten the RETAINING NUT (1).

### NOTE:

Zero and five are scale indicators only.  
From left to right, the first line is 5 and the last line 0.

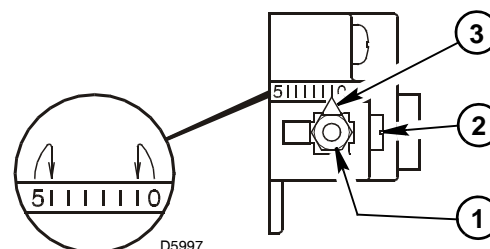

## OIL LINE CONNECTIONS

This burner is shipped with the oil pump set to operate on a **single** line system.

To operate on a **two** line system the by-pass plug **must** be installed.

**Warning: Do not** operate a **single** line system with the by-pass plug installed.

Operating a **single** line system with the by-pass plug installed will result in damage to the pump shaft seal.

**Note:** Pump pressure must be set at time of burner start-up.

A pressure gauge is attached to the **PRESSURE PORT** (8) for pressure readings.

Two **PIPE CONNECTORS** (5) are supplied with the burner for connection to either a single or a two-pipe system.

Also supplied are two **ADAPTORS** (3), two female 1/4" NPT, to adapt oil lines to burner pipe connectors.

All pump port threads are **British Parallel Thread** design.

Direct connection of NPT threads to the pump **will damage** the pump body.

Riello manometers and vacuum gauges do **not** require any adaptors, and can be safely connected to the pump ports. An NPT (metric) adapter **must** be used when connecting other gauge models.

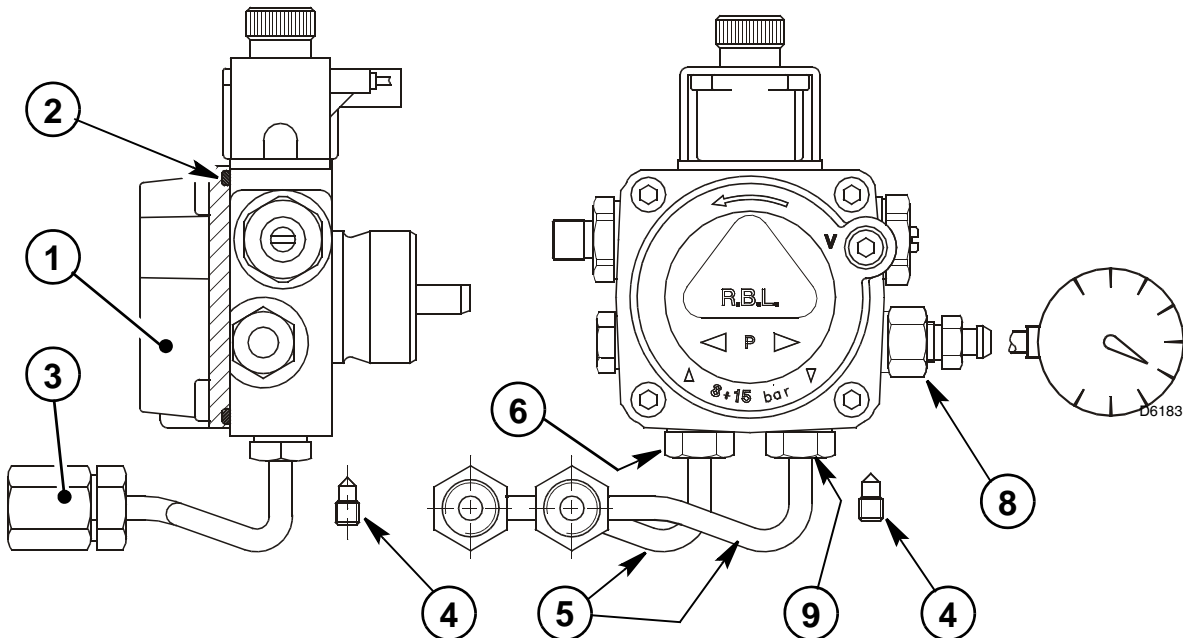

**SINGLE LINE (GRAVITY FEED SYSTEM)**

A) The burner is shipped configured for use in single line applications. No changes to the oil pump are required for use in single line applications.

**NOTE:** If the **pump cover (1)** is removed for any reason, be sure the O-ring (2), is properly seated in the pump cover (1) before re-attaching the pump cover to the pump housing.

B) Connect the pipe connector to the SUPPLY PORT (6) of the pump. Attach the required piping to this pipe connector. Be sure that the plug in the RETURN PORT (9) is tightened securely.

**TWO LINE (LIFT SYSTEM)**

A) If a two line system is required, install the By-pass plug (4) provided. The by-pass plug is installed in the return port (9) of the pump.

A 2.5 mm hexagonal key provided with the by pass plug is to be used to install the plug.

DO NOT use an inch size hexagonal key, damage to the by-pass plug may result. When operating on a two line system, supply and return lines should be the same diameter and both **should extend to the same depth inside the fuel tank.**

Be sure there are no air leaks or blockages in the piping system.

Any obstructions in the return line will cause failure of the pump shaft seal. Do not exceed the pipe lengths indicated in the tables.

To install the by-pass plug:

- 1) Remove the return plug (9).
- 2) Install the by-pass plug (4) using the 2.5 mm hexagonal key.

B) Attach the two PIPE CONNECTORS (5) to the pump SUPPLY and pump RETURN PORTS (6 and 9). Attach the required piping to these two pipe connectors using the NPT/METRIC ADAPTERS that are supplied with the burner.

**WARNING:**

- Pipe dope or Teflon tapes are NOT to be used on any direct oil connection to the fuel pump.
- The height 'P' in Pipe Length Charts should not exceed 13 feet (4 m).
- The vacuum should not exceed 11.44 inches of mercury.

**IMPORTANT:**  
An external, appropriately listed and certified oil filter must be placed in the fuel line between the fuel tank and the burner pump.

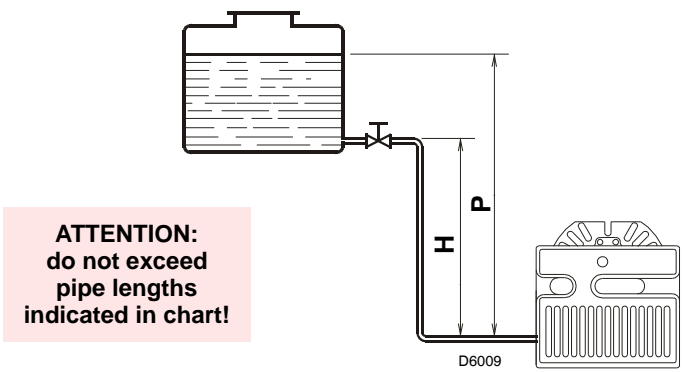

SINGLE LINE SYSTEM - PIPE LENGTHS					
H		3/8" OD		1/2" OD	
Feet	Meters	Feet	Meters	Feet	Meters
1 1/2	0.5	33	10	65	20
3	1.0	65	20	130	40
5	1.5	130	40	260	80
6 1/2	2.0	195	60	325	100

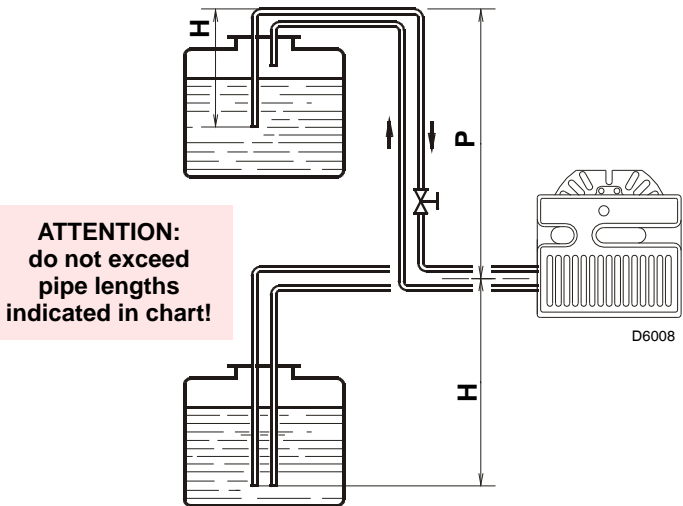

2 LINE (LIFT) SYSTEM - PIPE LENGTHS					
H		3/8" OD		1/2" OD	
Feet	Meters	Feet	Meters	Feet	Meters
0	0.0	115	35	330	100
1 1/2	0.5	100	30	330	100
3	1.0	80	25	330	100
5	1.5	65	20	295	90
6 1/2	2.0	50	15	230	70
9 1/2	3.0	25	8	100	30
11	3.5	20	6	65	20

## PUMP PURGE

### NOTE:

to protect the pump gears, it is advisable to lubricate the pump prior to purging a lift system. Apply oil through the VACUUM PORT (C).

### A) SINGLE LINE (GRAVITY FEED SYSTEM)

**A)** Loosen the bleeder valve (A) until oil flows out. Tighten the bleeder valve securely and start burner.

**B)** When bleeding the pump by pressure.

- 1) Loosen the bleeder valve (A).
- 2) Disconnect nozzle oil supply line at the pump nozzle port (B).
- 3) Attach a flexible plastic tube to the pump nozzle port, directing the oil flow into a bucket.
- 4) Loosen the screws securing the air tube cover, allowing it to be removed freely.
- 5) Holding the air tube cover in its proper location start the burner.
- 6) When the solenoid valve is engaged, approximately 10 seconds after starting, remove the air tube cover and shine a light source on the photo-cell, allowing it to see false light.
- 7) Run the burner until the fuel pump has been purged of air, then tighten the bleeder valve and immediately shut down the burner.
- 8) Reinstall the air tube cover and nozzle line.
- 9) The burner can now be started normally.

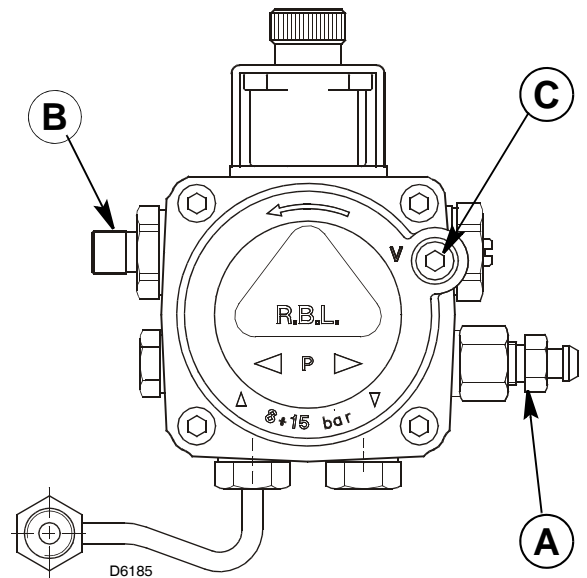

### WARNING:

Omitting steps 2 and 3 **will result in** a collection of unburned oil in the combustion chamber creating a **hazardous situation** upon burner startup.

### B) TWO LINE (LIFT SYSTEM)

Turn off the main power source to the burner and remove the air tube cover.

Shine a light source on the photo-cell (now visible where the air tube cover was removed), return power to the burner and activate the burner. With the light source in place, the burner will operate in prepurge only.

Once the burner is purged, turn off the power source and replace the air tube cover.

Return power to the burner.

The burner is now ready to operate.

### ATTENTION:

**It is important that the fuel line be completely sealed and free from air leaks or any internal blockages.**

### WARNING!

**WHEN THE BYPASS PLUG IS INSTALLED, A TWO PIPE SYSTEM MUST BE USED OR FAILURE OF THE PUMP SHAFT SEAL WILL OCCUR.**

## SETTING THE AIR ADJUSTMENT PLATE

- A) Regulation of the combustion air flow is made by adjustment of the manual AIR ADJUSTMENT PLATE (1) after loosening the FIXING SCREWS (2 & 3). The initial setting of the air adjustment plate should be made according to Column 5 in the Burner Set-up Chart.
- B) The proper number on the manual AIR ADJUSTMENT PLATE (1) should line up with the SETTING INDICATOR (4) on the fan housing cover. Once set, the air adjustment plate should be secured in place by tightening SCREWS 2 and 3.
- C) The final position of the air adjustment plate will vary on each installation. Use instruments to establish the proper settings for maximum CO<sub>2</sub> and a smoke reading of zero.

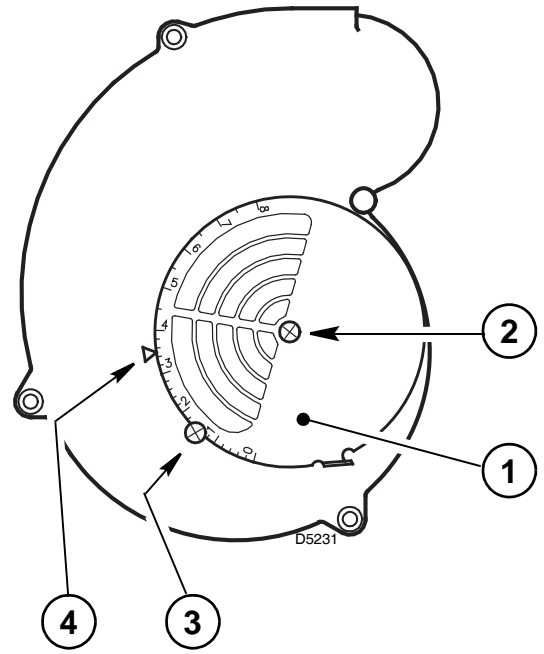

### NOTE:

Variations in flue gas, smoke, CO<sub>2</sub> and temperature readings may be experienced when the burner cover is put in place. Therefore, the burner cover **must** be in place when making the final combustion instrument readings, to ensure proper test results.

## BURNER SET-UP CHART

### NON-RETROFIT APPLICATIONS

If this burner is being installed in a packaged unit (ie. burner comes with a boiler or furnace), follow the installation and set-up instructions supplied with the heating unit, as settings will differ from those shown in this manual.

1		2	3		4	5
Actual Firing Rate ± 5%		Nozzle Size	Pump Pressure		Turbulator Setting	Air Damper Setting
GPH	kg/h	GPH	PSI	bar		
2.55	8.2	2.00 x 45°/60°	170	11.6	0.0	1.8
2.85	9.2	2.25 x 45°/60°	160	11	0.5	2.0
3.00	9.7	2.50 x 45°/60°	150	10	1.0	2.2
3.65	11.8	3.00 x 45°/60°	150	10	1.5	2.6
4.25	13.7	3.50 x 45°/60°	150	10	2.0	3.1
4.85	15.7	4.00 x 45°	150	10	3.0	4.5
5.45	17.6	4.50 x 45°	150	10	4.5	5.2
5.75	18.6	5.00 x 45°	140	9.6	5.0	5.5

### NOZZLES RECCOMANDED:

Monarch R-PLP, Delavan W-B, Danfoss S-B, Steinen SS-S, Hago P.

### NOTE:

A 45° degree nozzle is suggested, however, a 60° degree nozzle may be used in cases where the flame is unstable at light-off when operated at low ambient temperatures.

## DUCTED COMBUSTION AIR INTAKE APPLICATIONS

The “Ducted combustion air intake kit” (see P.N. 3002762 in the spare parts list - OPTIONAL), allows ducting of external air directly into the burner. A 4” diameter air intake is provided in the kit.

**To mount this kit on the burner, please follow the installation description given in the kit instruction sheet. Use a 4” to 6” pipe adapter (not supplied in the kit) to use a 6” diameter pipe.**

The settings of the burner must be according to the BURNER SETUP CHART – AIR INTAKE APPLICATIONS below.

MODEL F15 BURNER SETUP CHART with 4" diameter pipe							
Actual firing rate GPH	Nozzle size	Pump pressure PSI	Head setting	20 Ft. pipe length	50 Ft. pipe length	80 Ft. pipe length	100 Ft. pipe length
				Air Setting	Air Setting	Air Setting	Air Setting
2.55	2.00 x 45°/60°	160	0.0	2.0	2.1	2.1	2.1
2.85	2.25 x 45°/60°	160	1.0	2.3	2.4	2.4	2.5
3.10	2.50 x 45°/60°	150	2.0	2.3	2.4	2.4	2.5
3.65	3.00 x 45°/60°	150	3.0	2.9	3.3	3.4	3.5
4.30	3.50 x 45°/60°	150	4.0	3.5	4.1	4.1	4.4
5.14	4.00 x 45°/60°	165	5.0	6.0	6.0	6.1	6.4
MODEL F15 BURNER SETUP CHART with 6" diameter pipe							
Actual firing rate GPH	Nozzle size	Pump pressure PSI	Head setting	20 Ft. pipe length	50 Ft. pipe length	80 Ft. pipe length	100 Ft. pipe length
				Air Setting	Air Setting	Air Setting	Air Setting
2.55	2.00 x 45°/60°	160	0.0	2.0	2.0	2.1	2.2
2.85	2.25 x 45°/60°	160	1.0	2.3	2.3	2.4	2.4
3.10	2.50 x 45°/60°	150	2.0	2.3	2.3	2.4	2.4
3.65	3.00 x 45°/60°	150	3.0	2.9	3.0	3.0	3.1
4.30	3.50 x 45°/60°	150	4.0	3.5	4.1	4.1	4.2
5.14	4.00 x 45°/60°	165	4.5	5.5	5.6	5.6	5.7
5.60	4.50 x 45°/60°	155	5.0	6.1	6.2	6.3	6.4

### NOZZLES RECCOMANDED:

Monarch R-PLP, Delavan W-B, Danfoss S-B, Steinen SS-S, Hago P.

### NOTE:

A 45° degree nozzle is suggested, however, a 60° degree nozzle may be used in cases where the flame is unstable at light-off when operated at low ambient temperatures.

### NOTES:

- A) This kit is not suitable for direct vent applications.
- B) Always try to minimize the length of the air intake pipe.
- C) Reduce pipe length by 10 feet for every 90° elbow, 5 feet for every 45° elbow.
- D) Reduce pipe length by 6 feet for the 4” to 6” pipe adapter (if used).
- E) Air intake venting should be insulated 10 feet from air intake source with a minimum R7 foil lined insulation, to prevent condensation or corrosion of air intake venting.
- F) Use an approved type of air intake vacuum breaker and install it in the same room of the burner.  
This device should be tested to prove that the vacuum breaker balancer is set correctly and, in the event of intake air source being blocked, can provide enough combustion air for the burner. If the room where the burner is installed cannot provide enough air or air quality is a concern, an additional air inlet source must be provided to this room.
- G) On the outside of the wall, use an approved intake air hood, located above the snow line and in such way as to prevent leaves and/or other debris from blocking the air flow. Refer to local codes for proper location of inlet.

**COMBUSTION CHAMBER**

Follow the instructions furnished by the boiler/furnace manufacturer. Size retrofit application according to the appropriate installation codes (eg. CSA B139 or NFPA #31).

**BURNER START-UP CYCLE**

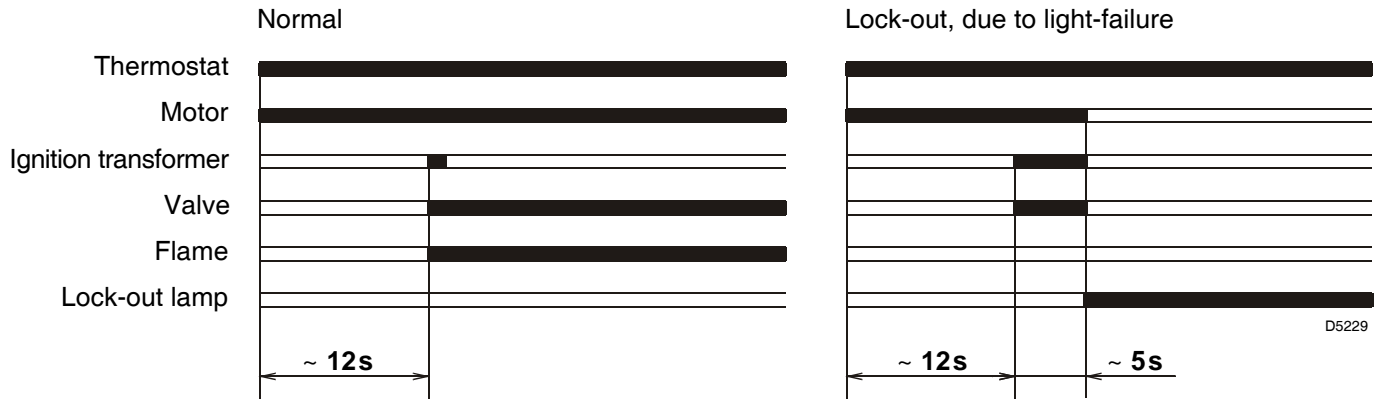

D5229

## EXPLODED SPARE PARTS LIST

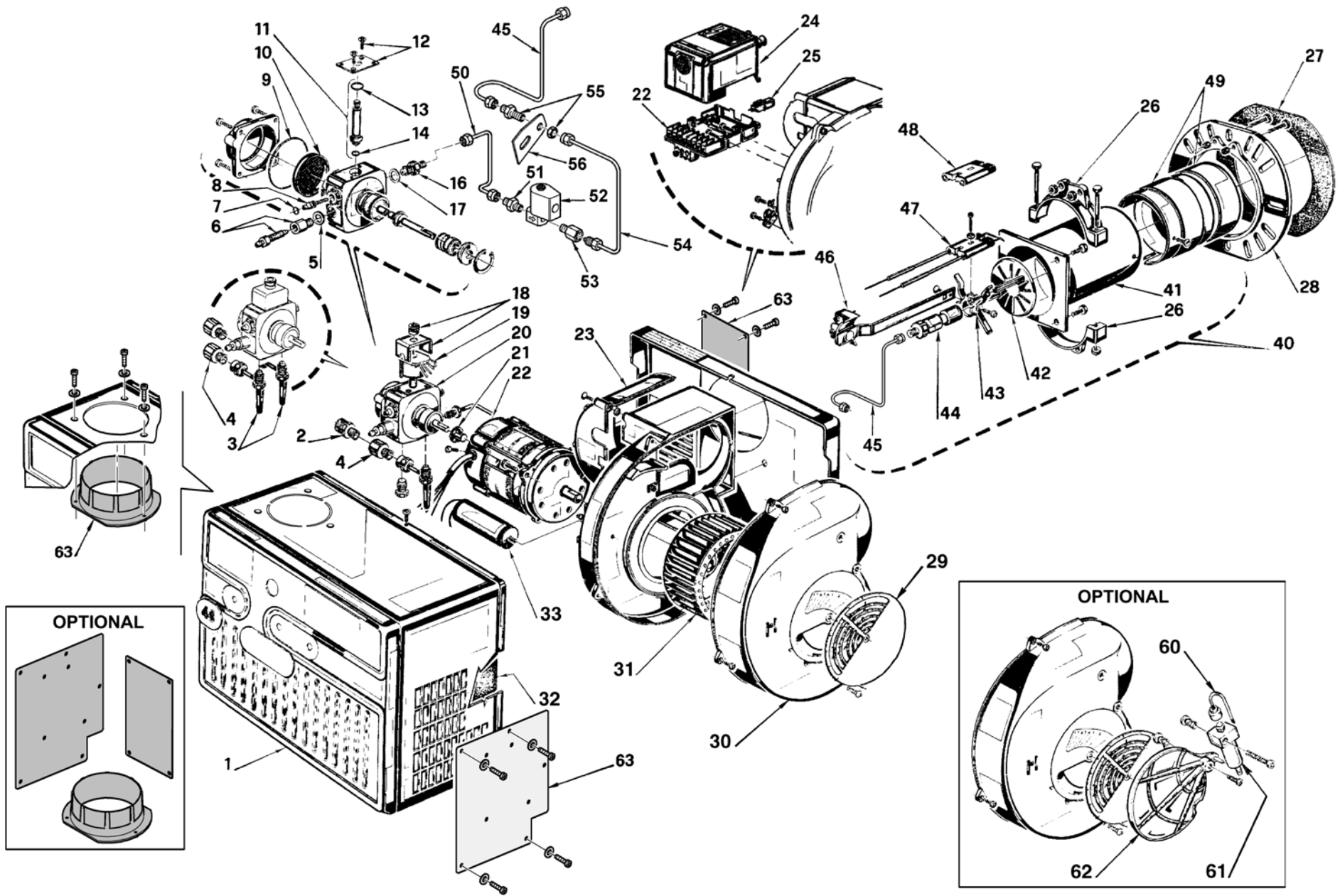



## SPARE PARTS LIST

No.	CODE	DESCRIPTION	No.	CODE	DESCRIPTION
1	3020510	BURNER BACK COVER	40	3949171	SHORT COMBUSTION HEAD 5" (274T1)
2	3006571	3/8" NPT/METRIC ADAPTER - MALE	41	3005892	SHORT AIR TUBE
3	3006994	PIPE CONNECTOR - SUPPLY AND RETURN	42	3005897	TURBULATOR DISC
4	3005847	1/4" NPT/ METRIC ADAPTER - FEMALE	43	3005896	CROSS - CASTING
5	3007077	CRUSHABLE METAL WASHER	44	3006965	NOZZLE ADAPTER
6	3007568	BLEEDER	45	3006987	NOZZLE OIL TUBE - SHORT
7	3007028	O-RING - PUMP PRESSURE REGULATOR	46	3005900	REGULATOR ASSEMBLY - SHORT
8	3007202	REGULATOR SCREW	47	3005902	ELECTRODE ASSEMBLY - SHORT
9	3007162	C7010002 O-RING - PUMP COVER	48	3005869	ELECTRODE PORCELAIN
10	3005719	PUMP SCREEN	49	3005895	END CONE
11	3006925	VALVE STEM			
12	3007203	VALVE STEM PLATE	40	3949172	LONG COMBUSTION HEAD 10" (274T2)
13	3007029	O-RING - VALVE STEM UPPER	41	3005893	LONG AIR TUBE
14	3007156	O-RING - VALVE STEM LOWER	42	3005897	TURBULATOR DISC
15	3002278	PRIMARY CONTROL SUB BASE	43	3005896	CROSS - CASTING
16	3007268	NOZZLE OUTLET FITTING	44	3006965	NOZZLE ADAPTER
17	3007087	CRUSHABLE METAL WASHER	45	3006988	NOZZLE OIL TUBE - LONG
18	3006553	COIL U-BRACKET AND KNURLED NUT	46	3005901	REGULATOR ASSEMBLY - LONG
19	3002279	COIL	47	3005903	ELECTRODE ASSEMBLY - LONG
20	3007802	C7001010 PUMP	48	3005869	ELECTRODE PORCELAIN
21	3000443	PUMP DRIVE KEY	49	3005895	END CONE
22	3005845	MOTOR			
23	3007318	AIR TUBE COVER			OPTIONAL
24	3002280	PHOTO-CELL	60	3007816	CAPILLARY TUBE
25	20010004	PRIMARY CONTROL 530SE/C 24V	61	3006911	HYDRAULIC JACK
26	3005849	SEMI FLANGE	62	3000880	HYDRAULIC AIR SHUTTER
27	3005852	MOUNTING GASKET	63	3002762	DUCTED COMBUSTION AIR INTAKE KIT
28	3005851	UNIVERSAL MOUNTING FLANGE			
29	3007206	MANUAL AIR SHUTTER			
30	3007211	AIR INTAKE HOUSING			
31	3005799	FAN			
32	3007358	ACOUSTIC LINER			
33	3005846	CAPACITOR 16 µF			
50	3020300	OIL LINE			
51	3020307	MALE ADAPTOR			
52	3020299	SOLENOID VALVE			
53	3020304	ADAPTOR			
54	3020301	OIL LINE			
55	3020303	ADAPTOR AND NUT			
56	3020302	BRACKET			

## BURNER START-UP REPORT

Model number: _____	Serial number: _____
Project name: _____	Start-up date: _____
Installing contractor: _____	Phone number: _____

<b>LIGHT OIL OPERATION</b>			
Oil supply pressure: _____	CO <sub>2</sub> : Low Fire _____	High Fire _____	
Oil suction pressure: _____	O <sub>2</sub> : Low Fire _____	High Fire _____	
Control Power Supply: _____	CO: Low Fire _____	High Fire _____	
Burner Firing Rate: _____	NO <sub>x</sub> : Low Fire _____	High Fire _____	
Low Fire Flame Signal: _____	Net Stack Temp - Low Fire: _____	High Fire _____	
High Fire Flame Signal: _____	Comb. Efficiency - Low Fire: _____	High Fire _____	
Low Fire Nozzle Size: _____	Overfire Draft: _____		
High Fire Nozzle Size: _____	Smoke number: _____		

<b>CONTROL SETTINGS</b>			
Operating Setpoint: _____	Low Oil Pressure: _____		
High Limit Setpoint: _____	High Oil Pressure: _____		
Low Gas Pressure: _____	Flame Safeguard Model Number: _____		
High Gas Pressure: _____	Modulating Signal Type: _____		

<b>NOTES</b>



---

# RIELLO

RIELLO S.p.A.  
I-37045 Legnago (VR)  
Tel.: +39.0442.630111  
[http:// www.riello.it](http://www.riello.it)  
[http:// www.rielloburners.com](http://www.rielloburners.com)

---

# RIELLO

35 Pond Park Road  
Hingham, Massachusetts,  
U.S.A. 02043

RIELLO BURNERS NORTH AMERICA

**1-800-4-RIELLO**

1-800-474-3556

<http://www.riello-burners.com>

2165 Meadowpine Blvd  
Mississauga, Ontario  
Canada L5N 6H6