



Installation, Operation and Service Manual

KLC Condensing Unit

95% + EFFICIENCY

OIL FIRED LOWBOY FURNACE

Model KLC- 100

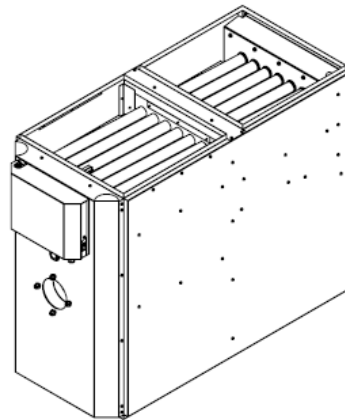

CONFORTO CHE

**INSTALLATIONS MUST MEET ALL LOCAL AND FEDERAL
CODES THAT MAY DIFFER FROM THIS MANUAL**

***Please read the manual in its entirety before beginning installation.
This manual must be kept with the furnace for future reference.***

GRANBY FURNACES INC.

PO Box 637
12118 Hwy 209
Parrsboro Nova Scotia Canada
B0M 1S0
902-254-2543

www.granbyindustries.com

09-19-2018

G2012-E3 Rev.K

WARNING

This furnace is designed to operate with the ALL 20 flue-pipe baffles correctly installed. The **maximum** normal flue temperature is 120 Degrees °F after 10 minutes of operation at a maximum distance of 18 inches from the breach of the unit.

IT IS MANDATORY TO MEASURE THE FLUE-PIPE TEMPERATURE, as part of the combustion test, UPON INSTALLATION. This measurement must be taken through a sampling hole as described in section 5.2 of this manual and as close as possible to the breach of the unit, through the plastic flue pipe downstream of the black rubber connector.

If the temperature is OVER 120 Degrees °F:

1. Check that ALL 20 baffles are in place. To do this you must remove the black plastic collector pan as described in section 7.1;
2. Check that the correct nozzle is installed in the burner;
3. Check that you have the correct burner pump pressure;
4. Make sure the blower door is closed during operation;
5. Make sure that the condensate disposal system is not blocked. If that is the case, unblock.

IF THE UNIT IS STILL OPERATING OVER 120 DEGREES F AFTER THESE CHECKS, CALL GRANBY FURNACES INC. "CUSTOMER CARE".

PROLONGED OPERATION OVER 120 DEGREES °F COULD LEAD TO UNSAFE OPERATION, PREMATURE FAILURE OF THE EQUIPMENT AND BODILY HARM.

TABLE OF CONTENTS
KLC
Oil

1.0	IMPORTANT SAFETY ADVICE	3
2.0	PRODUCT INFORMATION	4
3.0	FURNACE INSTALLATION	6
	3.1 PLACEMENT & VENTING	7
	3.2 INSTALLATION CODES	8
	3.3 INSTALLATION INFORMATIONS	8
	3.4 VENTING OPTIONS	8
	3.5 CONDENSATE DRAIN LINE INSTALLATION	11
4.0	ACCESSORIES INSTALLATION	12
5.0	BURNER INSTALLATION AND SPECIFICATIONS	13
	5.1 ASSEMBLY & INSTALLATION OF THE BURNER	13
	5.2 SET BURNER FOR EFFICIENT OPERATION	14
	5.3 TECHNICAL INFORMATION	16
6.0	FURNACE OPERATION AND SETTINGS	17
	6.1 BLOWER SETTING	17
	6.2 FAN TIMER CONTROL BOARD (ST9103 A 1028)	18
	6.3 (ST9103 A 1028) CONTROL BOARD SEQUENCE	19
	6.4 SERVICING – FAN TIMER (ST9103 A 1028)	20
	6.5 FLUE AND FRESH AIR PIPE SERVICING	23
7.0	SERVICE AND MAINTENANCE	23
	7.1 CLEANING HEAT EXCHANGER	24
	7.2 BLOWER REMOVA L	25
8.0	ELECTRICAL / WIRING DIAGRAM	26
9.0	EXPLODED PARTS VIEW	27
10.	START-UP TEST RESULTS	29

1.0 IMPORTANT SAFETY ADVICE

Please read and understand this manual before installing, operating or servicing the furnace. To ensure you have a clear understanding of the operating procedures of the unit please take the time to read the **IMPORTANT SAFETY ADVICE** section of this manual. This furnace is equipped with an electronically commutated motor (ECM) for the main circulation blower. The ECM will significantly reduce the electrical power consumption and will enhance home comfort.

WARNINGS

NEVER burn garbage or paper in the unit.

NEVER store combustible material around it.

DO NOT attempt to start burner when excess oil has accumulated, when unit is full of vapour or when heat exchanger is very hot.

DO NOT use gasoline, crankcase draining's or any oil containing gasoline.

CAUTION

DO NOT START THE BURNER UNTIL ALL FITTINGS, COVERS AND DOORS ARE IN PLACE. **DO NOT** TAMPER WITH THE FURNACE OR CONTROLS, CALL A QUALIFIED BURNER TECHNICIAN. **DO NOT** STORE OR USE GASOLINE OR OTHER FLAMMABLE VAPOURS AND LIQUIDS IN THE VICINITY OF THIS UNIT OR ANY OTHER APPLIANCE.

DANGER

Do not use this furnace as a construction heater. Use of this furnace as a construction heater exposes it to abnormal conditions, contaminated combustion air and lack of air filtering. Failure to follow this warning can lead to premature furnace failure which could result in a fire hazard and/or bodily harm and/or material damage.

NOTE: DO NOT INSTALL IN SPACE WHERE TEMPERATURE DROPS BELOW 32°F (0°C) FREEZING POINT. CONDENSATE WILL FREEZE AND WILL DAMAGE UNIT.

IMPORTANT

This manual contains instructional and operational information for the **KLC OIL-FIRED FURNACE**. Read the instructions thoroughly before installing furnace or starting the burner. Consult local authorities about your local **FIRE SAFETY REGULATIONS**. All installations must be in accordance with local state or provincial codes. Improper installation will result in voiding of warranty.

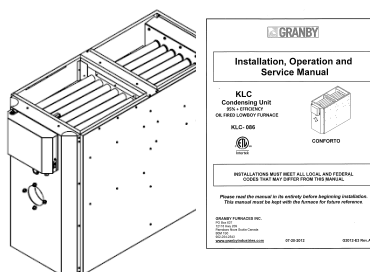

2.0 PRODUCT INFORMATION

CLEARANCE (minimum) TO COMBUSTIBLES

Top of Supply Plenum	1"	(25 mm)
Front (Maintenance)	24"	(610 mm)
Rear (Maintenance)	24"	(610 mm)
Side – Non-Access	1"	(25 mm)
Side – Access maintenance	24"	(610 mm)
Vent Pipe	0"	(0 mm)
Floor (Can be installed directly on combustible or non-combustible)		

AIR/BLOWER DATA

Maximum external static pressure	0.5" wc
Maximum cooling unit capacity	3.0 tons.
Maximum air temperature rise	See pages 16 and 30
High Limit temperature	215°F
Thermostat anticipator	See thermostat instructions

MOTOR/BLOWER

KLC-100: 1/2 hp ECM Motor / G 12 x 7 Direct Drive Blower

FAN/HIGH LIMIT CONTROL

Honeywell ST9103A1028 Fan Center & Thermo-Disk (7" stem)

THERMOSTAT

Any wall thermostat

FUEL

Not heavier than No. 2 furnace oil.

ELECTRICAL – 120 Volts, 60 Hz

Canada	Less than 12 amps, circuit protection 15 amps.
USA	13.3 amps, circuit protection 20 amps.

VENT PIPE CONNECTION

3" S636 PVC (type BH ClassIIA, 65°C). CANADA
And CPVC (type BH ClassIIB,90°C). USA

CONDENSATE DRAIN

PLASTIC HOSE ½" diameter

CLEANOUTS

Rear Cover & Burner Opening

AIR FILTER

KLC-100 2 x 12" x 20" x 1" non pleated UL approved

PLENUM DIMENSIONS KLC-100 CONFORTO

Cold air return	(A)	20" x 20" (508 x 508 mm)
Hot air supply	(B)	20" x 20" (508 x 508 mm)
Plenum spacing	(C)	3" (76 mm)

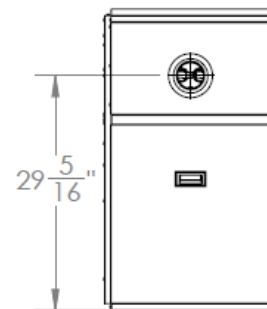
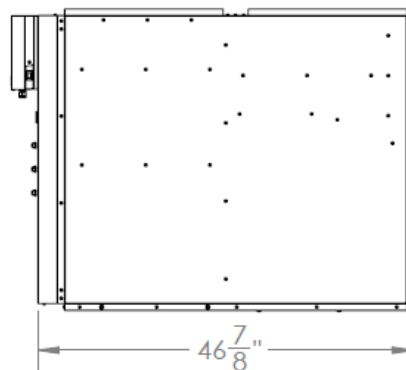
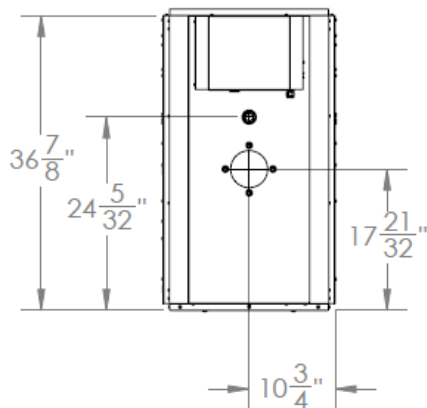
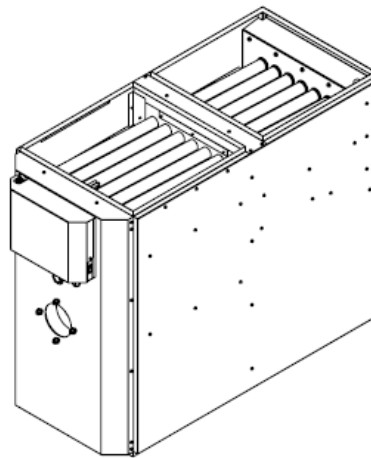
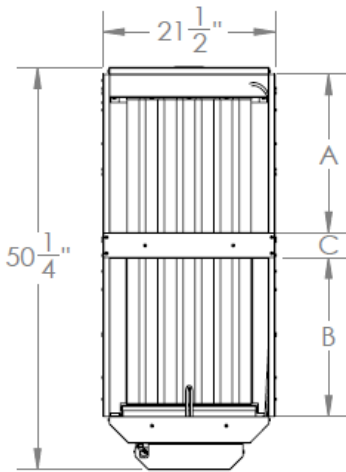

KLC-100 - DIMENSIONS

Dimensions are in inches

3.0 FURNACE INSTALLATION

OIL TANK & PIPING

Tank installation must conform to local requirements.

Install according to the applicable code such as CSA B139 and NFPA 31. Minimize number of connections in suction line and make all connections air tight. Use a pipe joint compound suitable for oil on all pipe threads. To reduce possibility of air leaks, tighten stem packing gland nut on any valves installed in the suction line. Also, be sure the oil filter is tight, as filter gaskets often shrink. Check for kinks in the oil lines as well as for possible air pockets and for loose connections. Two filters as shown below are recommended. Optional tank gauge protectors and outlet protectors are available at your local dealer.

ONE PIPE SYSTEM

Where the tank outlet is above the burner and when the oil flows by gravity to the oil pump, a single-stage fuel unit with a single oil line to the pump may be used.

TWO PIPE SYSTEM

When a single line is not suitable, use double line or contact your dealer for special oil line fittings. Install by-pass plug on burner fuel pump as specified in the burner manual.

Rear Flue Furnace illustration

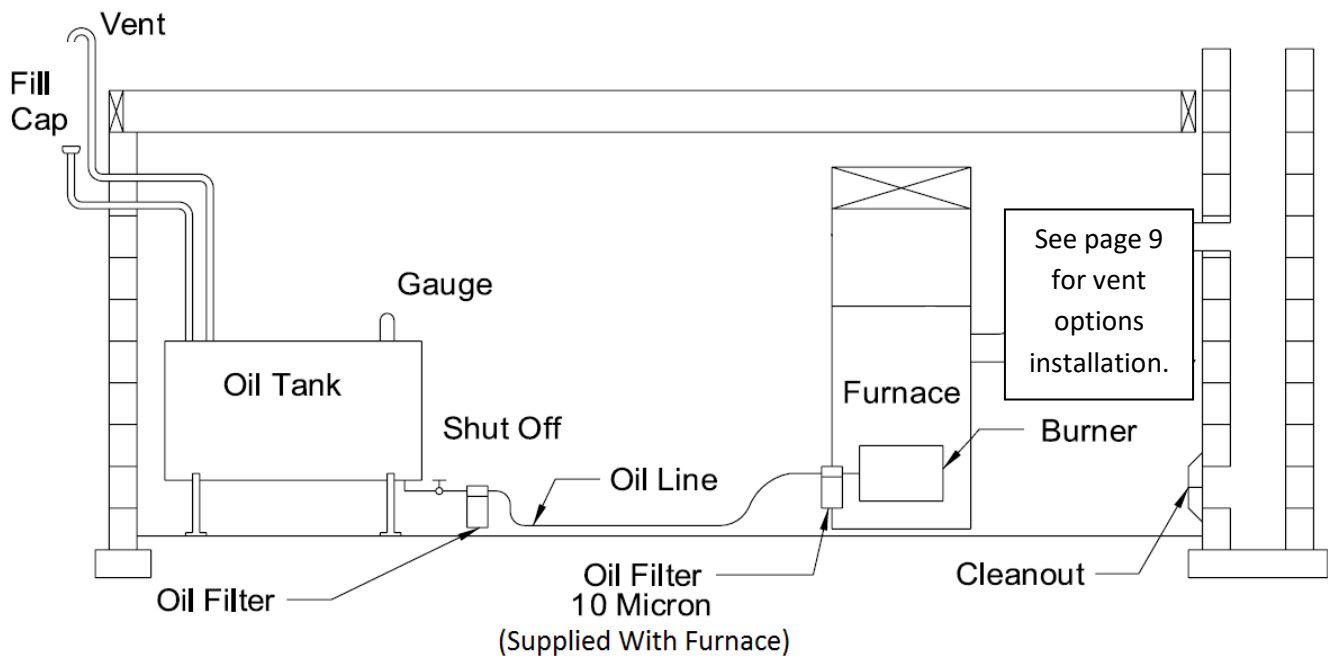

Oil Tank and Piping

3.1 PLACEMENT & VENTING

Furnace installation shall conform to the required installation code for oil-fired equipment (USA: NFPA 31, Canada: CSA B139).

FLOOR SUPPORT COMBUSTIBLE – If required, support furnace on five (5) concrete blocks. Make sure the center of the furnace base is supported. For a furnace installed on a combustible floor, consult the applicable code and authorities having jurisdiction on this application. The floor must support the weight.

VENT The KLC can be vented vertically through the roof or horizontally through the wall. The appropriate venting material must be rated to a minimum operating temperature of 65°C (149°F). The approved vent material is S636 PVC-40 in Canada and CPVC-40 (or its equivalent) in the United States. Keep vent/flue pipe as short as possible with a minimum. 1/4" per foot **upward slope**. See section 5.3 for more information.

WARNING **BE AWARE THAT REMOVING BAFFLES REDUCES THE UNIT'S EFFICIENCY AND INCREASE THE OUTLET TEMPERATURE. A MODIFIED UNIT IS NO LONGER ENERGY STAR APPROVED. THIS COULD RESULT IN FIRE HAZARD AND/OR OTHER HAZARDOUS CONDITIONS THAT MAY LEAD TO BODILY HARM.**

COMBUSTION & VENTILATION AIR Install openings and ductwork to the furnace room providing fresh outside combustion and circulation air for cooling the furnace casing, as installation code requires (USA NFPA 31, Canada CSA B139). If installed in a closed room, provide two free air ventilation openings of at least 8" x 12" (96 sq. in.) free flow area near ceiling and floor. Oil burners must have sufficient air to allow vent systems to operate properly. If balance flue burner his used, combustion air must be duct to the outside as per instructions.

ELECTRICAL Wire according to the National Electrical Code (Canadian or USA) or local codes. Use a separately fused #12 electrical line directly from the service panel to the furnace junction box. Install a manual shut-off switch at the door or stairway to furnace room so furnace can be shut off remotely.

CLEARANCES Before placing unit, review installation clearances as shown on furnace operating decal or section **PRODUCT INFORMATION** (page 4).

BLOWER DOOR

Do not operate without blower door properly installed. This could result in fire hazard and/or hazardous conditions that may lead to bodily harm.

3.2 INSTALLATION CODES

INSTALLATION MUST COMPLY WITH THE REQUIREMENTS OF AUTHORITIES HAVING JURISDICTION. . All local and national codes governing the installation of oil burning equipment, wiring and venting must be followed. Some of the applicable codes are:

CAN/CSA B 139	Installation Code for oil burning Equipment
NFPA 31	Installation Code for Oil Burning Equipment
ANSI/NFPA 90B	Warm Air Heating and Air Conditioning Systems
ANSI/NFPA70	National Electrical Code
CSA C 22.1	Canadian Electrical Code
ANSI/NFPA 211	Chimneys, Fireplaces, Vents and Solid Fuel Burning Appliances

The latest versions of the above codes that have been approved for use in the location of the installation must be used.

3.3 INSTALLATION INFORMATIONS

VENT PIPE See NFPA 31 (USA) or CSA B139 (Canada) code. Breech is certified for 3" S636 PVC-40 vent pipe in Canada and S636 CPVC-40 (or its equivalent) in the United States. The appropriate venting material must be rated to a minimum operating temperature of 65°C (149°F). See section 5.3 for more technical information.

RETURN AIR Ensure that the furnace return air temperature to the unit is not lower than 50°F (10°C)

3.4 VENTING OPTIONS

System 636 in 3 inch diameter is recommended for the KLC. The Installation Methods to be used are detailed in the instruction manual of the product of your choice (IPEX or PolyPro. Flex). An online Solvent Cementing Training is also available at theret site.

The minimum vent linear length is 5 feet. The maximum horizontal equivalent length allowed is 80 feet. Each 90° elbow accounts for 8 feet. As an example if the system has 5 elbows, 40 linear feet of vent can be used. The vent is connected to the furnace using the supplied neoprene coupling.

VENTING OPTIONS INSTALLATION

TWO PIPES SYSTEM

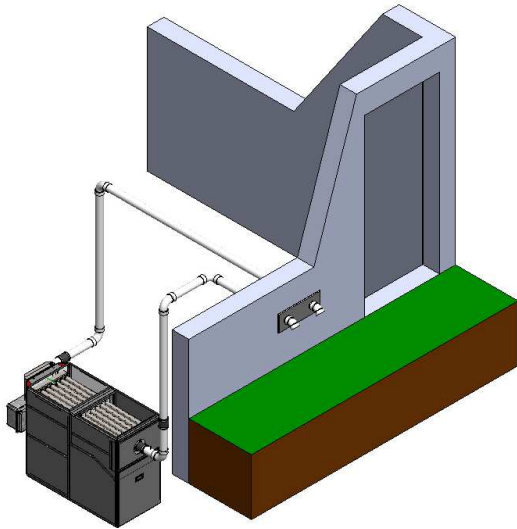

- Two small openings of 3"1/2+
- BF3 Riello burner approved

COAXIAL SYSTEM

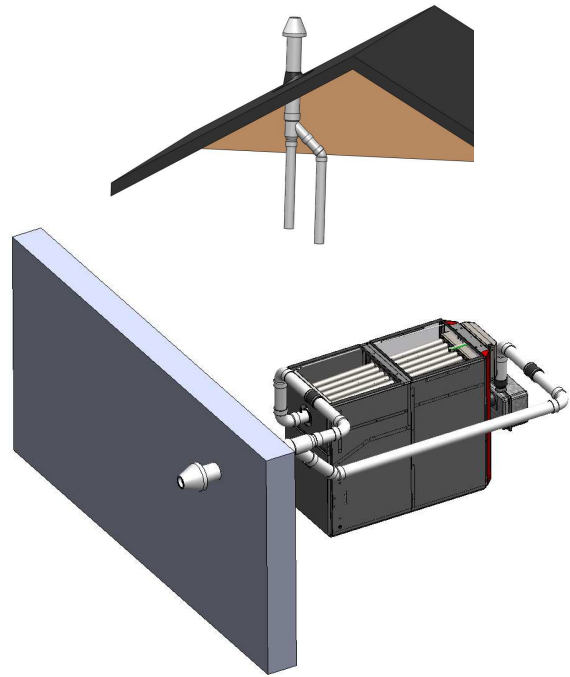

- Single opening of 4"1/2+
- BF3 Riello burner approved

VERTICAL ONE PIPE SYSTEM

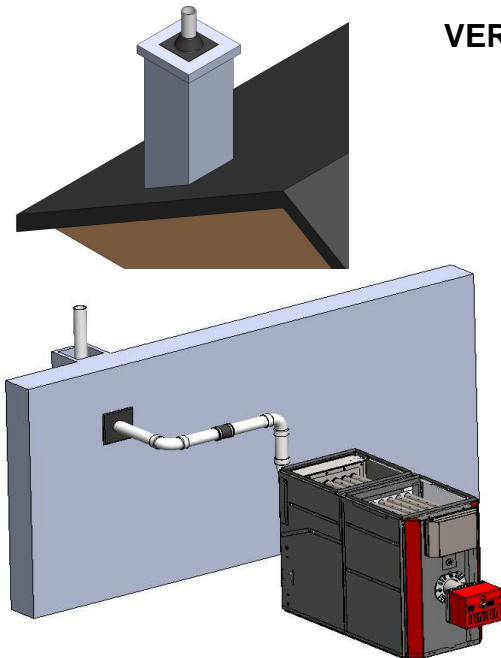

- Especially for retrofit installation
- Easy to fit one pipe in 7"x7" chimney tile
- Avoid wall opening
- **No clearance restriction**
- Perfect where there is no access to external wall in the mechanical room
- F3 Riello burner approved

WALL TERMINAL INSTALLATION REQUIREMENTS

In Canada

Refer to the CSA B139 Code for the placement of the vent termination

In United States

Refer to the NFPA31 Code for the placement of the vent termination

COAXIAL WALL CLEARANCE

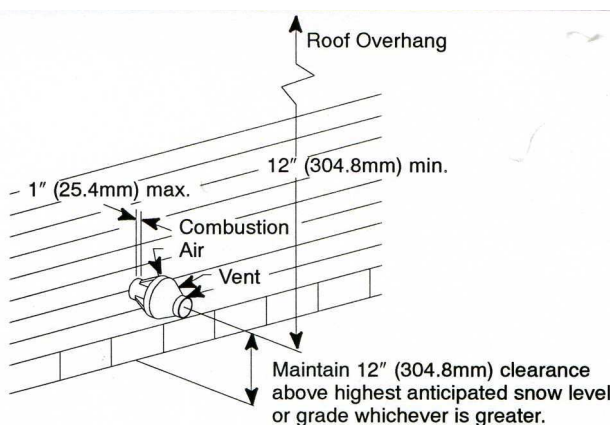

TWO PIPES WALL CLEARANCE

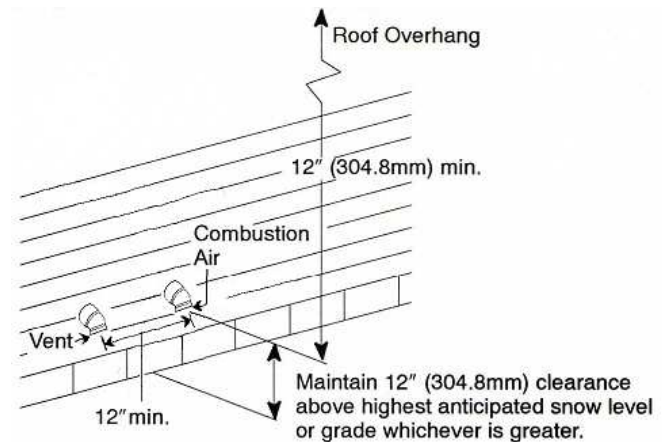

All piping must be on same wall

Outlet termination clearance above grade and roof overhang

Check flue and combustion air pipes for any leak

VENT TERMINATION WARNING

It is the responsibility of the homeowner to ensure that the area around the vent terminal and air intake is free of snow, ice and debris. The vent terminal should be checked during heavy snowstorms to ensure proper operation.

3.5 CONDENSATE DRAIN PIPE INSTALLATION

Drain Trap Assembly Overview

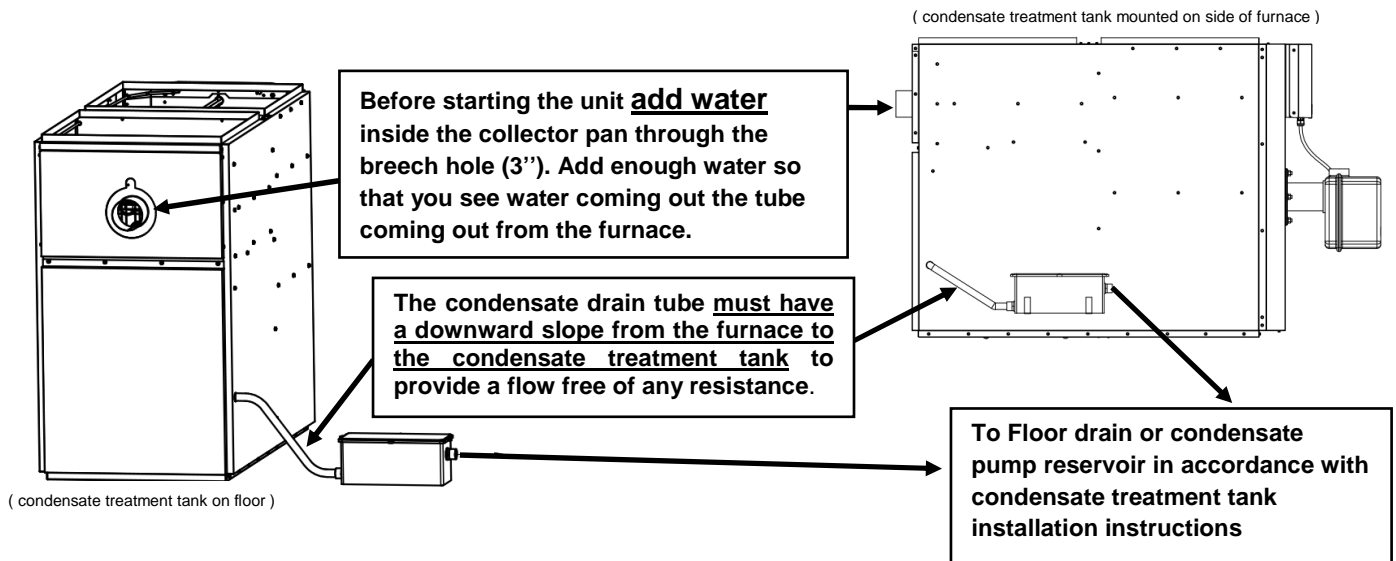

“ Not to do ”

The condensate drain tube from the furnace to the condensate treatment tank shall :

- Never contain a “P” trap;
- At no point, be elevated higher than the furnaces' drain outlet;
- Be without sharp bends (*kinks*) that could cause the drain tube to collapse;
- Be without any obstruction that could prevent the condensate to flow freely.

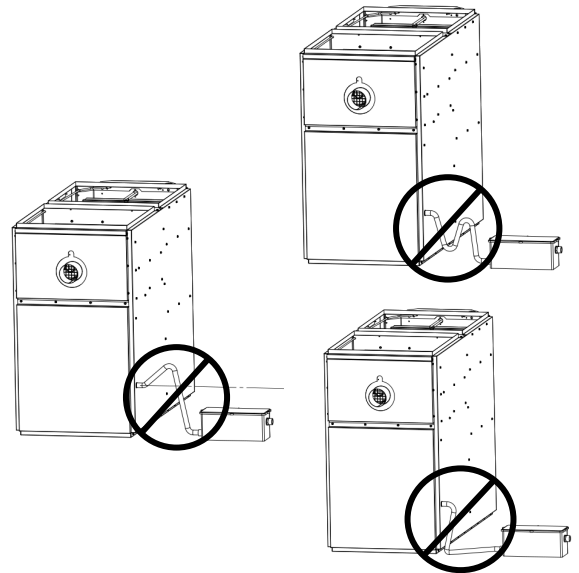

IMPOTANT

Please note that the warranty to this product may be void if damages to the furnace heat exchanger are caused by blockage of the condensate fluid evacuation system. It is the responsibility of the installer, service technician and homeowner to make sure that nothing can obstruct the evacuation of the condensate fluid from the furnace. The condensate fluid neutralizer cartridge must be changed annually and the condensate fluid evacuation system must also be verified annually for proper functioning.

4.0 ACCESSORIES INSTALLATION

AIR CONDITIONING SYSTEM

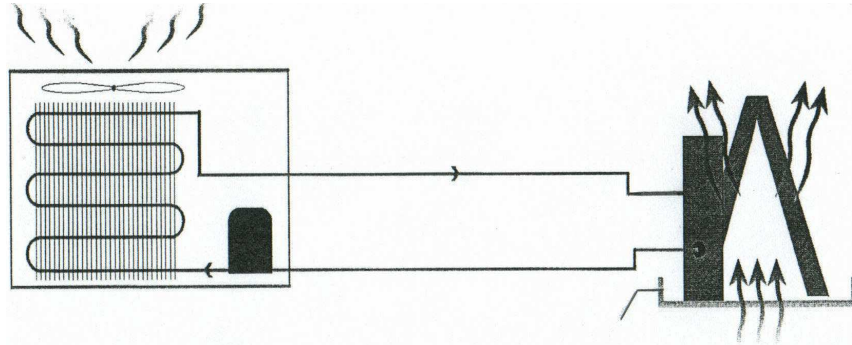

OUTSIDE CONDENSER UNIT

INSIDE EVAPORATOR COIL

An air conditioning **evaporator coil** may be installed on the supply side **only**. Coils installed on the return side will cause damage on the unit; this will shorten the unit life and may cause products of combustion to enter the house. Wire as per wiring label and diagram. **Height of the coil above the unit supply shall be at least 4" (102 mm).**

See **A/C coil Manufacturers Requirements.**

To check the AC coil total air flow resistance, see procedure at page 30.

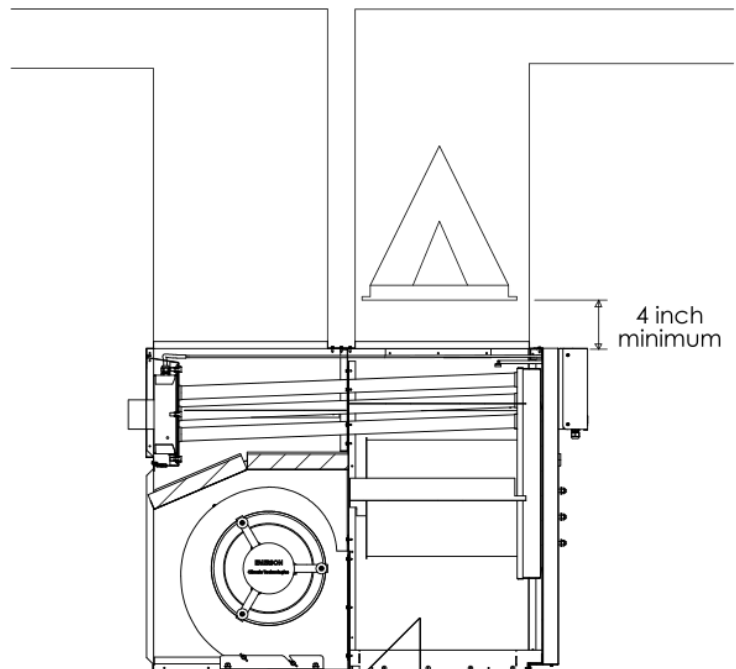

HUMIDIFIER

If a humidifier is installed ensure that no water can drip or run from it into the furnace. This would cause deterioration and void the furnace warranty.

5.0 BURNER INSTALLATION AND SPECIFICATIONS

5.1 ASSEMBLY & INSTALLATION OF BURNER

ASSEMBLY Check that the burner model is correct for furnace rating required. Assemble as per burner manufacturer's instructions.

SELECT NOZZLE Select oil input, nozzle and burner configuration as shown on furnace operating decal.

INSTALL NOZZLE Install selected nozzle, check for clean seating and tighten in nozzle adaptor.

ELECTRODES See burner manufacturer's instructions for correct setting

INSERTION

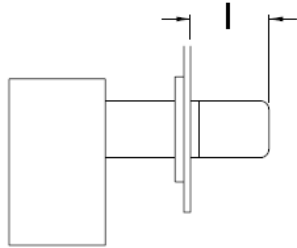

BURNER INSERTION (I)		
	in	mm
RIELLO	2 1/2	63

MOUNT BURNER Tighten top nut first so burner tips down slightly. The burner is always installed in an upright position by four (4) nuts.

PUMP BY-PASS PLUG For one pipe system factory setting (no plug).

PRESSURE TUBE

BF3 BURNER – 2 PIPES (IPEX) VENTING

THE PRESSURE TUBE MUST BE CONNECTED ON THE APPROPRIATE LOCATION (TOP RIGHT) ON THE BURNER CASING.

F3 BURNER – 1 PIPE (IPEX) VERTICAL VENTING

THE PRESSURE TUBE MUST BE CUT AT THE EXIT OF THE ELECTRICAL BOX. IT SHOULD MEASURE ATMOSPHERIC PRESSURE.

WIRING

Refer to wiring diagram for correct burner connections (see page 26).

THERMOSTAT

Connect the thermostat wires to the fan timer control board (ST9103).

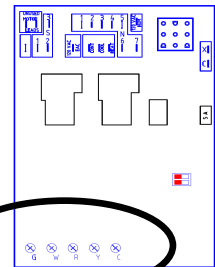

5.2 SET BURNER FOR EFFICIENT OPERATION

BURNER SETTING Use burner settings in the table on page 16 or operating decal as a guide to set burner, particularly for nozzle changes. **Those settings are only starting points for the adjustments and are not meant as final settings.**

PUMP PRESSURE Refer to the table on page 16 or operating decal.

AIR SETTING Use air settings on page 16 as a guide to set air adjustment. **Those settings are only starting points for the adjustments and are not meant as final settings.**

SAMPLING HOLE A sample hole is required for the burner set-up. If permitted by the flue pipe's installation instructions, drill a 3/8" diameter hole on top of the vent pipe and use the supplied test port plug to seal after burner setup. If drilling a hole through the flue pipe is not permitted by the manufacturer's instructions, install an access tee and plug in accordance with the flue pipe's installation instructions.

Rear Flue Furnace illustration

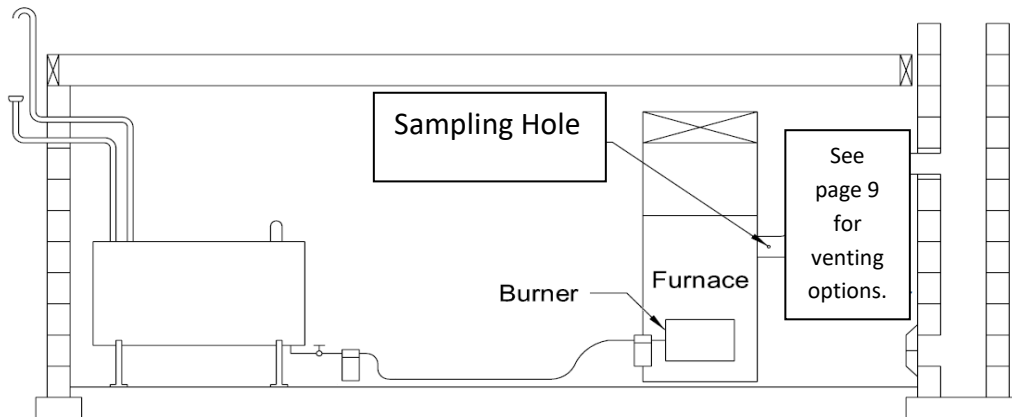

COMBUSTION TEST: All your tests must be done with the burner cover on

ANALYZER Use an electronic gas analyzer for setup and record information on the furnace setup decal. Failure to do so may void warranty. Always set flame with proper draft, smoke and CO₂ measurements.

NOTE: Some electronic gas analyzers do not account for recovery of latent heat and give low efficiency readings. Use the table below to determine the AFUE.

Nozzle Size	CO ₂ Concentration	Stack Temperature	AFUE
Usgph	%	°F	%
0,50	11.5	98 TO 108	95,4
0,60	12.5	109 TO 115	95,4

**COMBUSTION
SETTING/
EFFICIENCY**

After 10 minutes of normal operation, take a **smoke test** and adjust the burner to obtain a reading of "1" on the smoke scale.

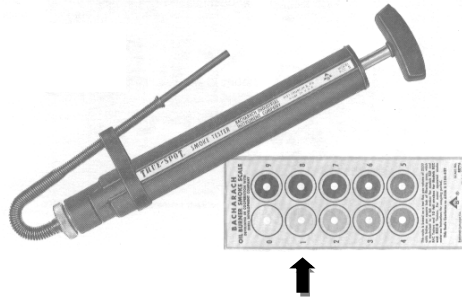

To reach the maximum smoke test value, a 10 full slow steady pump action is required.

Take a CO₂ test and note the result.

CO₂ test can be done mechanically or electronically

(18 full slow steady pump action)

Open the air band on the burner to reduce your CO₂ lecture by 1.5% with a two pipes installation. On a one pipe installation reduce your CO₂ by 1%.

You now have a perfect "0" of smoke

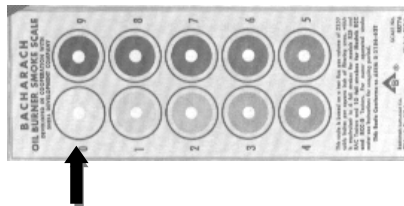

Relation between % of CO₂ and O₂

CO ₂ (%)	O ₂ (%)	Excess Air (%)
13.5	2.6	15.0
13.0	3.3	20.0
12.5	4.0	25.0
12.0	4.6	30.0
11.5	5.3	35.0
11.0	6.0	40.0

5.3 TECHNICAL INFORMATION

KLC- 100

	Two pipes Venting		One pipe Venting	
Riello Burner	BF3 Riello		F3 Riello	
Unit Model	KLC-V1-*073-03	KLC-V1-*088-03	KLC-E1-*073-03	KLC-E1-*088-03
Firing Rate (USGPH)	0.55	0.65	0.55	0.65
Input (BTU/h)	77,000	91,000	77,000	91,000
Output (BTU/h)	74,000	87,000	74,000	87,000
Nozzle	0.50 70W	0.60 70W	0.50 70W	0.60 70W
Pump Pressure (psi)	145	145	145	145
Turbulator Setting	0	0	0	0
Air Gate Adjustment	3.75	4.50	2.50	3.25
Energy Star Approved	YES	YES	YES	YES
AFUE (%)	95.8	95.8	95.8	95.8
CO ₂ (%)	11.5	12.5	11.5	12.5

General Information

(*) In the Unit Model number, is specific information of the product for administration only.

Energy Star ECM motor (0.2'' wc to 0.5''wc)

Temperature Rise (°F)	52-85	58-85	52-85	58-85
Blower Speed	MEDIUM	MEDIUM	MEDIUM	MEDIUM

Static Pressure

Blower Speed	ECM 1/2 hp	
	0.2" wc	0.5" wc
HI	1300	1230
MHI	1225	1160
MED	1140	1050
MLO	1025	980
LO	775	750

Approved Vent (Pipe must be rated for a minimum of (149°F) operating temperature).

Model of KLC	Vent configuration & Vent material	Combustion Air	Maximum vent length	Vent
KLC-V1	Concentric & 2 pipes system Canada: S636 PVC-40 USA: CPVC schedule 40 or equivalent	From outside the structure	80' equivalent horizontal	3"
KLC-E1	Vertical / 1pipe system Canada: S636 PVC-40 USA: CPVC schedule 40 or equivalent	From inside the structure	50' equiv. horizontal +vertical vent.	3"

6.0 FURNACE OPERATION AND SETTINGS

SHUTTING FURNACE DOWN

POWER OFF Turn off main power breaker or disconnect.

FUEL OFF Shut off manual fuel supply valve.

Always keep manual fuel supply valve shut off if the burner is shut down for an extended period of time.

RESTARTING FURNACE

Follow this procedure before restarting a unit that has been shut down for an extended period of time.

INSPECTION Have the furnace/system serviced and inspected by a **qualified technician**.

FUEL Turn on fuel supply and check that there are no leaks.

POWER Turn on power and check that the furnace starts and operates as usual.

OPERATION If the furnace/system fails to operate or operates in an unusual manner, call your service technician. If the burner fails to operate at any time, call a qualified burner technician.

6.1 BLOWER SETTING

Ensure power is off when adjusting blower setting. For heating, use the blower speeds shown on the furnace specifications to give a temperature rise according to the technical information tables on page 16. The Lo blower speed can be used for air circulation when heating or cooling are not required. Set blower speeds to match the installation requirements.

FAN & LIMIT CONTROL

Limit	215°F – Factory set
Fan On	45 seconds after the burner starts
Fan Off	Adjustable on board (see page 18)

THERMOSTAT ANTICIPATOR SETTING

Adjust to thermostat manufacturer's instruction

6.3 ST9103A 1028 CONTROL BOARD SEQUENCE

ST9103 Heating Sequence

- 1) Thermostat calls for Heat.
- 2) Burner starts
- 3) Blower starts after **45** seconds
- 4) Burner shuts down after call for heat is satisfied
- 5) Blower stops according to adjusted (FAN OFF) Dip switch selection

ST9103 Cooling Sequence

- 1) Thermostat calls for cooling
- 2) Blower starts immediately
- 3) Cooling unit starts
- 4) Blower stops immediately after cooling demand is satisfied
- 5) Cooling unit stops

Honeywell ST9103A 1028 Electronic Board

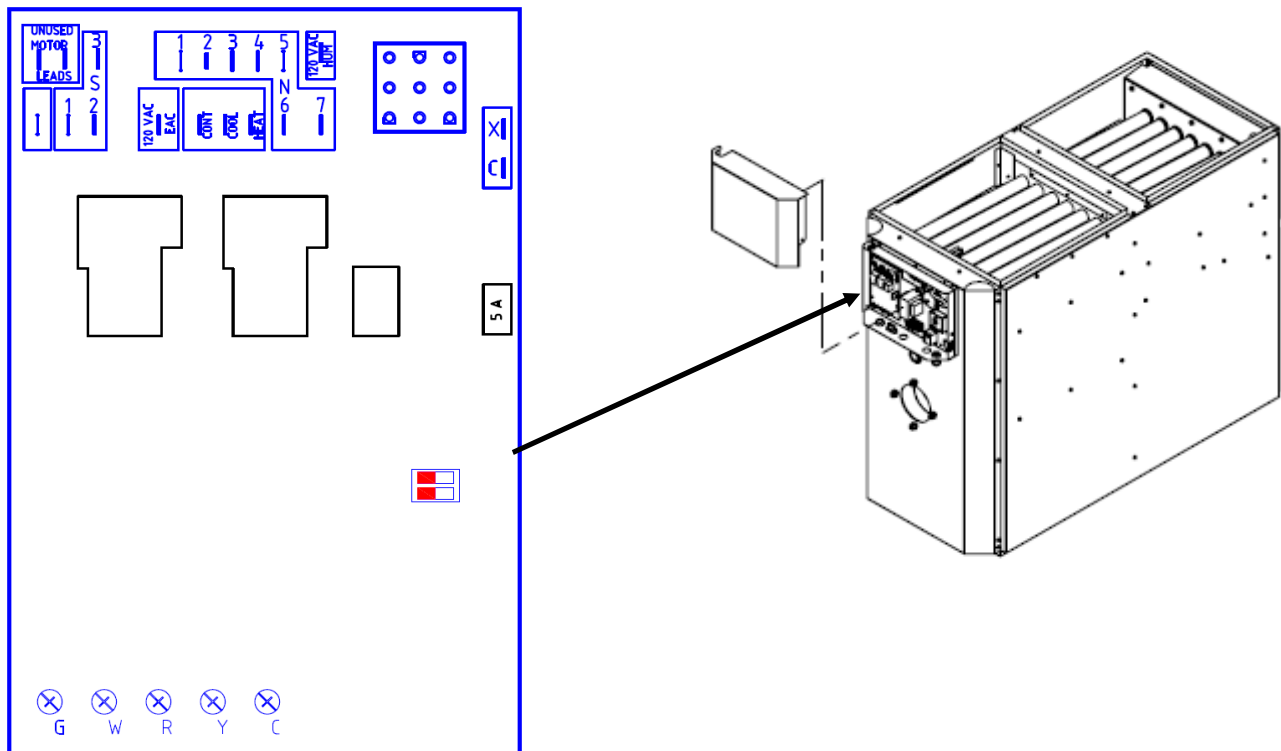

6.4 SERVICING - FAN TIMER ST9103A1028

Trouble shooting the Honeywell electronic board ST 9103

Before trouble shooting the board, check for the 5 amp. fuse

For accurate trouble shooting, follow step by step the Trouble Shooting Chart.

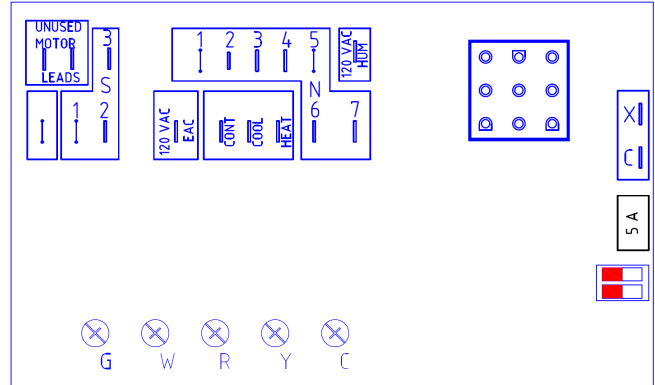

Step	Possible Cause	Check-out procedure	Corrective action
No Heat			
1	Incoming supply	Check for 120 Volts between terminal S2 and 3 on electronic fan control	Yes - Move to next step No - Check breaker main power switch
2	Transformer	Check for 120 Volts between terminal S3 and 4 on electronic fan control. Check for 24 Volts between terminal X and C on electronic fan control	Yes - Move to next step No - Check for bad connection Yes - Move to next step No - Change Transformer
3	Electronic Fan control	Check for 24 Volts between R and C Check for 24 Volts between terminal W and C	Yes - Move to next step No - Change the electronic board Yes - Move to next step No - Check thermostat and wiring
4	Warning: Make sure the quick connect cable is fully inserted on the board		
	Limit Control	Check for 120 Volts on each terminal of the high limit	Yes - Move to step # 5 No - Move to next step
		Check for 120 Volts coming from the main plug-in of the electronic fan control to the limit control	Yes - Move to next step No - Change the electronic fan control
		Check for 120 Volts coming out of the limit control	Yes - Move to step # 5 No - Failure on the limit control circuit . Temperature too high . Bad limit control

Step	Possible Cause	Check-out procedure	Corrective action
No Heat			
5	Riello Burner	<p>Check for 120 Volts on the black wire, contact (COM) on the burner activation relay.</p> <p>Check if oil primary control is on reset</p> <p>Check for 24 v. coming from the electronic fan control to the collector Hi-temp. switch</p> <p>Check for 24 v. coming from the Hi-limit temp. switch to the condensate overflow switch</p> <p>Check for 24 v. coming from the condensing overflow switch to the burner activation relay coil.</p> <p>Check for 120 Volts on the contact (No) of burner activation relay</p> <p>Check for 120 Volts on terminal # 1 of the bypass timer relay. (15sec.)</p> <p>Check for 120 volts on the orange wire coming to the burner (L)</p>	<p>Yes - Move to next step No - Back to step # 4 or check for bad connection</p> <p>Yes - Press reset button No - Move to the next step</p> <p>Yes - Move to next step No - Change the electronic fan control</p> <p>Yes - Move to next step No - Check manual reset</p> <p>Yes - Move to next step No - Check the condensing overflow switch</p> <p>Yes - Move to next step No - Change the burner activation relay</p> <p>Yes - Move to next step No - Change the relay, check for 120v. on pressure switch terminals.</p> <p>Yes - Failure on the burner No - Change the electronic control</p>
6	<p>Blower</p> <ul style="list-style-type: none"> • Low speed <p>Check if the constant low speed switch is ON</p>	<p>Check for 120 Volts at the "CONT" terminal on the electronic fan control</p> <p>Check for 120 Volts on both side of the constant low speed switch</p>	<p>Yes - Move to next step No - Change the electronic fan control</p> <p>Yes - Check "LOW" speed on the blower motor No - Change the switch</p>

No Cooling

7	Blower High speed	Check for 24 Volts between G and C on electronic fan control	Yes - Move to next step No - Check thermostat and wiring; if it's OK, then change the electronic fan control
	Cooling Speed	Check for 120 Volts at the "COOL" terminal of the electronic fan control	Yes - Check "COOL" speed on the blower motor No - Change the electronic fan control
	Heating Speed (45 sec. delay)	Check for 120 Volts at the "HEAT" terminal of the electronic fan control	Yes - Check "HEAT" speed on the blower motor No - Change the electronic fan control

8	Condensing unit	Check for 24 volts between terminal Y and C on the electronic fan control	Yes - Compressor ON No - Check thermostat and wiring
---	-----------------	---	--

Electronic air filter and Humidifier

9	Electronic air filter	Check for 120 Volts on terminal "EAC" of the electronic fan control (thermostat must call a Heat, Cool or Fan ON demand)	Yes - Electronic filter failure No - Change the electronic fan control
10	Humidifier	Check for 120 Volts on terminal "HUM" of the electronic fan control (burner must be energized)	Yes - Humidifier failure No - Change the electronic fan control

**If the Honeywell electronic fan control (ST9103A1028) is defect, replace the control with the same part recommend by Granby Industries
Part #... 4CB-00-FAN0-00**

6.5 Flue and Fresh Air Pipe Servicing

To facilitate servicing, use 3 neoprene couplings when installing the plastic pipes

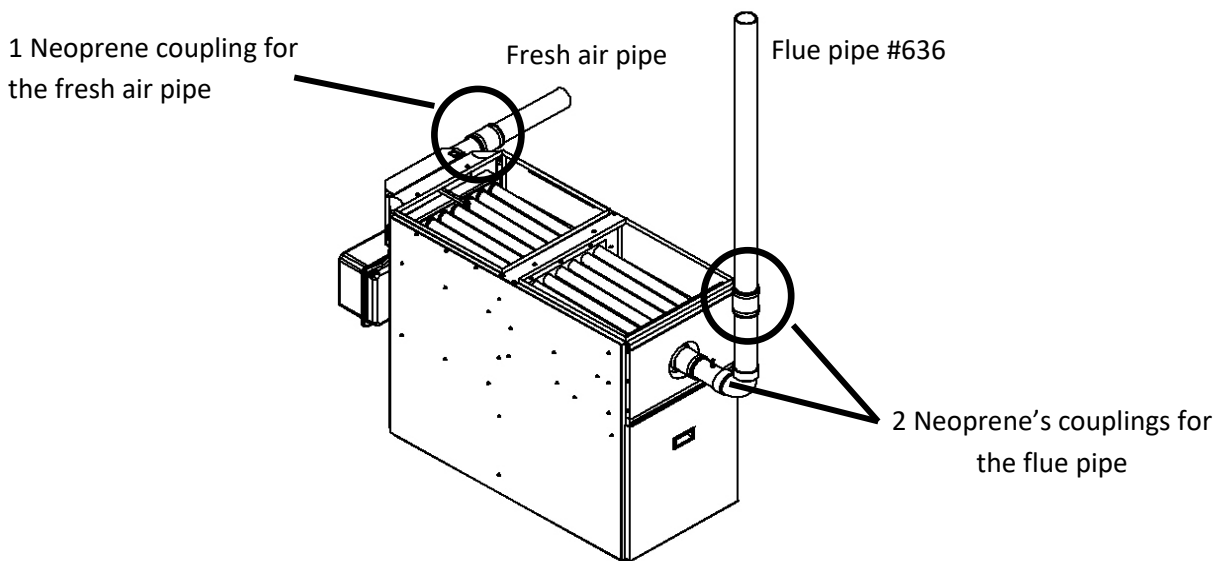

7.0 SERVICE AND MAINTENANCE

REGULAR MAINTENANCE

Check complete operation **at least once a year**. In Canada see B139, (Maintenance), in Unites States see NFPA 31, for recommended servicing procedure. Clean flue pipes on a regular basis. Check flue and combustion air pipes for any leak.

CHANGING NOZZLE

It is recommended that the nozzle be replaced once a year. If a new nozzle of a different size is installed, change the blower speed according to section **BURNER INSTALLATION AND SPECIFICATIONS** or operating decal as required.

7.1 CLEANING HEAT EXCHANGER

Heat exchanger must be inspected every heating season. Refer to instructions and pictures below.

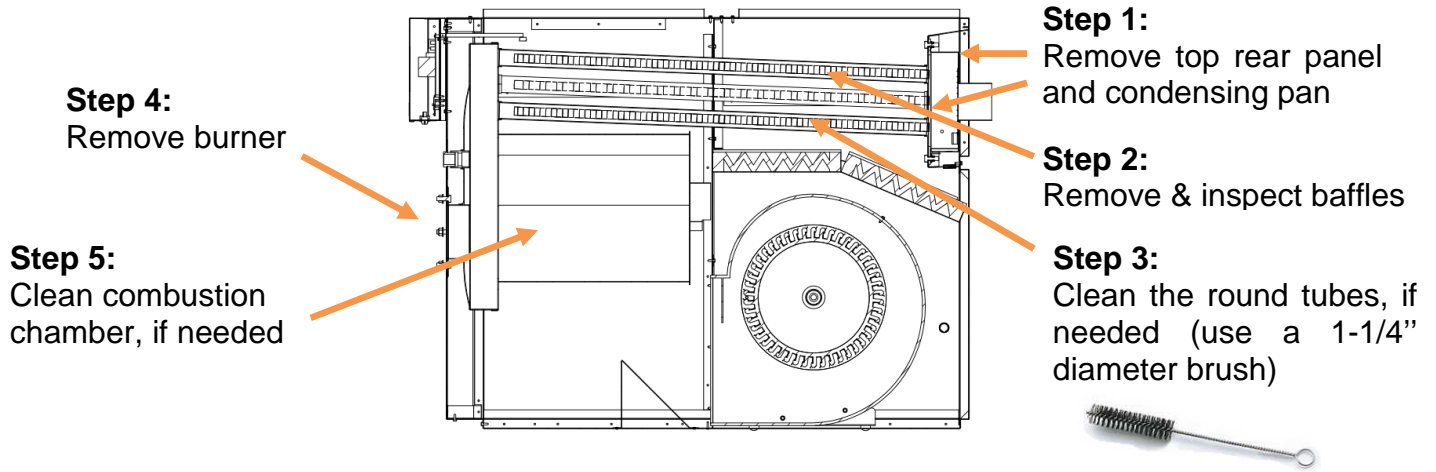

After cleaning, do not forget to put back the baffles!!

- **IMPORTANT SEE WARNING PAGE 7**

CONDENSATE NEUTRALIZER

The media bag contained within the condensate treatment tank should be replaced once per year or for every 600 USG (2300L) of oil used in the furnace or if the PH level at the outlet of the treatment tank falls below 5.0 (whichever comes first). A replacement media bag can be acquired from your local dealer.

The condensate from the furnace is slightly acidic with a pH of about 4; a neutral fluid would have a pH of 7. If the condensate is not conditioned, damage could result in waste water handling system which would result in expensive repairs.

During the first hours of operation. The appliance self-cleans its interior. The result being that for the first 20 hours of activity, the condensate liquid will be brownish and thereafter stabilize and become of normal "water" color.

AIR FILTERS

To maintain furnace performance and safety, replace dirty filters at least once every heating season or as required. Use new approved disposable filters of the same size and type. Dirty, clogged or wrong sized filters will impair the furnace performance and may cause the furnace to shut down or overheat.

7.2 BLOWER REMOVAL

This furnace has a blower sealing system, which is designed to be tight and rattle free. Refer to the instructions and pictures below.

- 1) Shut off oil and power to furnace.
- 2) Open blower compartment.
- 3) Disconnect the wiring to the blower motor.
- 4) Remove the air filter.
- 5) Remove the four (4) wing nuts securing the blower side to the base panel bracket.

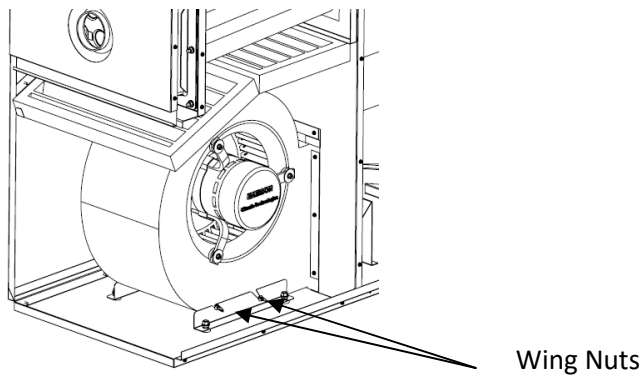

- 6) Slide the blower toward you and then lift the blower straight up. Shift the blower out of the furnace.

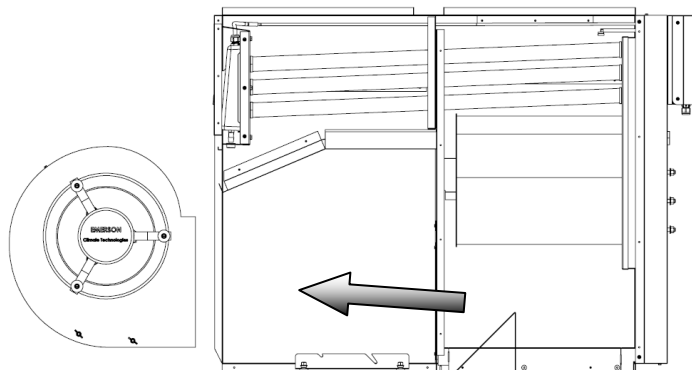

Put back the blower assembly using the reverse procedure. Ensure wiring and ground wire are correctly reconnected.

8.0 ELECTRICAL / WIRING DIAGRAM

WIRING DIAGRAM

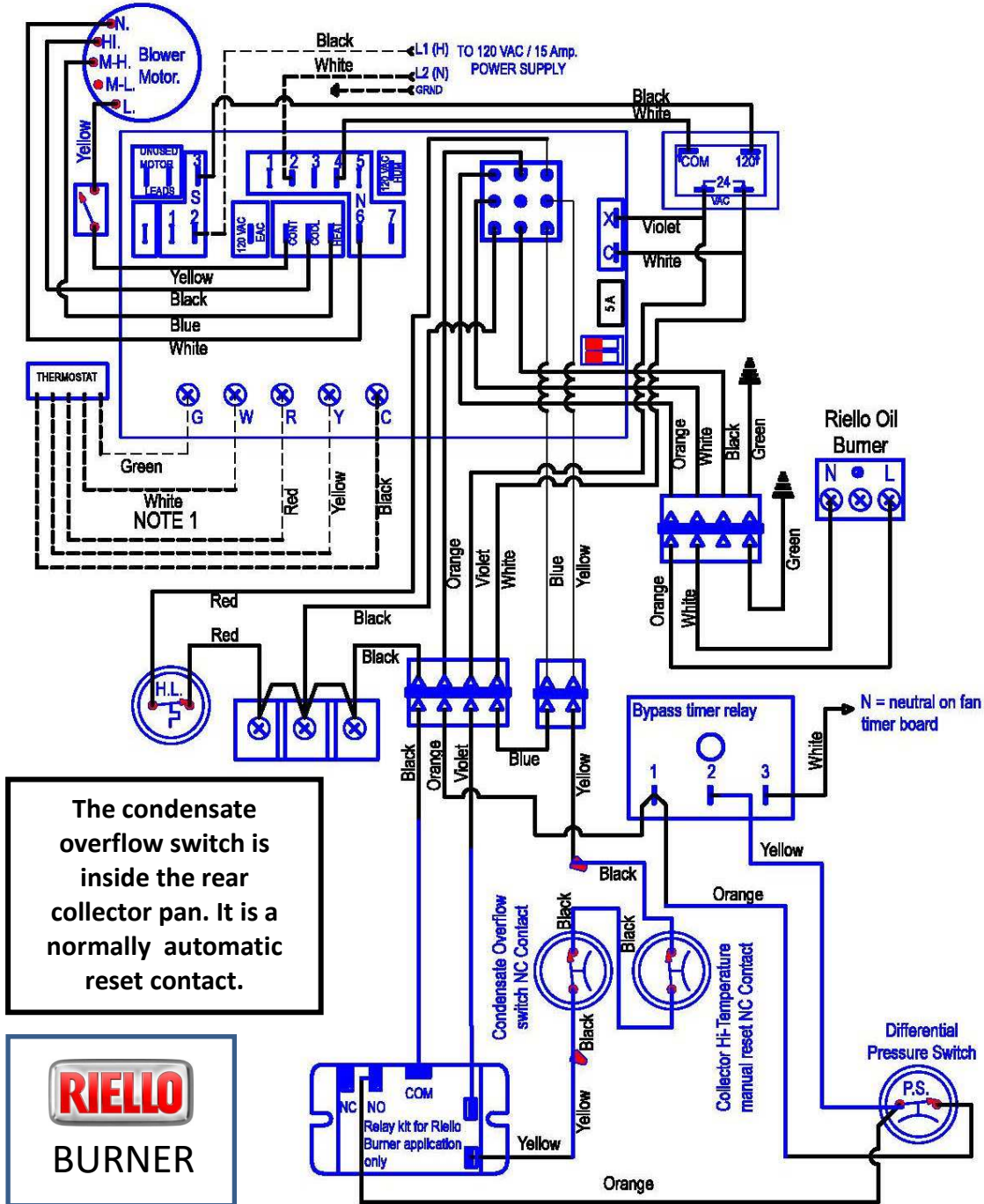

The condensate overflow switch is inside the rear collector pan. It is a normally automatic reset contact.



9.0 EXPLODED PARTS VIEW

KLC-100 CONFORTO Exploded Parts View

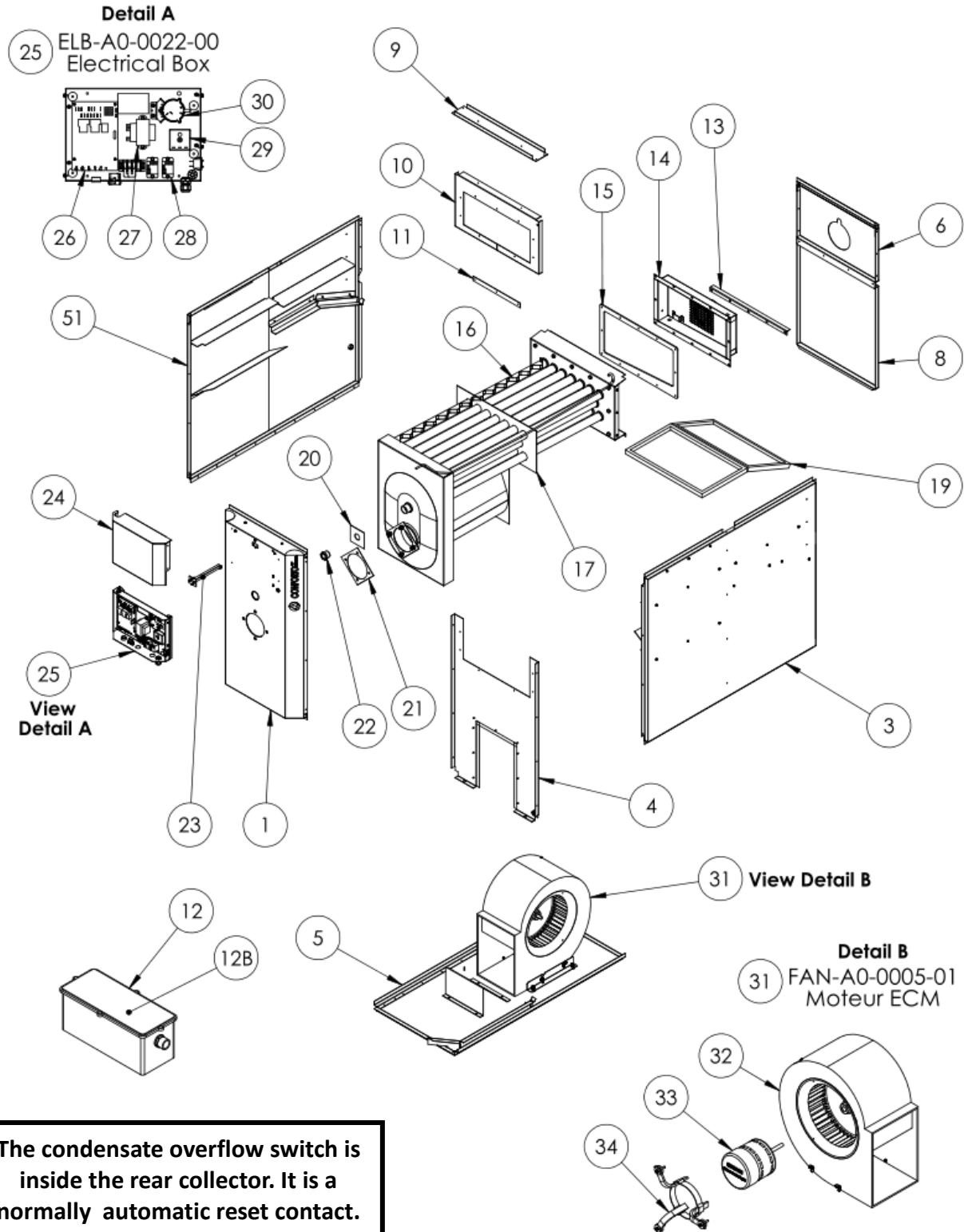

The condensate overflow switch is inside the rear collector. It is a normally automatic reset contact.

KLC-100 – Conforto Part List

ITEM	PART NUMBER	DESCRIPTION	QTY
1	CAB-A0-0047-00	Front Panel Assembly	1
2	CAB-A0-0031-00	Left Panel Assembly	1
3	CAB-A0-0032-00	Right Panel Assembly	1
4	CAB-A0-0033-00	Divider Panel Assembly	1
5	CAB-A0-0046-00	Base Panel Assembly	1
6	CAB-P0-0022-00	Top Rear Panel	1
8	CAB-P0-0018-00	Blower Door Panel	1
9	CAB-P0-0248-00	Upper Divider – Part 2	1
10	CAB-P0-0143-00	Upper Divider	1
11	CAB-P0-0012-00	Insulation Support	1
12	3CN-02-0375-00	KLC Condensate Neutralizer Tank (NBT-23)	1
12B	3CN-23-1111-00	KLC - Condensate Neutralizer refill bag (Mg(OH) ₂)	1
13	CAB-P0-0370-00	Rear Collector Stiffener	1
14	KLC-12-COLL-01	KLC - Stainless collector - version 2	1
15	3GK-18-COLL-00	Gasket Condensing Collector 3/16" HT Neoprene	1
16	HEX-A0-0008-00	Pipe Baffle 1.5in Assembly	20
17	INS-P0-0038-00	Divider Filler Gasket – 20 Holes	1
18	HEX-A0-0002-00	Condensing Heat Exchanger Assembly	1
19	3AF-01-1220-01	Air Filter 12" x 20" x 1" Non-Pleated (Strata Type)	2
20	INS-P0-0018-00	Sight Glass Insulation	1
21	INS-P0-0017-00	Burner's Flange Insulation	1
22	3SG-0P-1030-5A	Glass Sight Clear 1" NPT Hex With THD Seal	1
23	4SD-00-0215-00	High Limit Snap Disc (215°)Auto Reset #36T01B7 47655	1
24	ELB-P0-0018-00	Cover Electrical Box – Low Boy Model	1
25	ELB-A0-0022-00	Electrical Box Assembly – Low Boy Condensation	1
26	4CB-00-FAN0-00	ST9103A1028 Electronic Board	1
27	4TF-00-40VA-00	Transformer HTC-01A0BB01 40 VA	1
28	4RY-00-24V0-00	Relay AE04001 24VAC Form C SPDT 24V	1
29	4RY-BP-0175-15	Timer Bypass NC 15 Second Delay	1
30	4SW-PS-9370-55	MPL NC Pressure Switch 0.55 inches	1
31	FAN-A0-0005-01	Fan Motor Assembly KLC ECM Motor	1
32	3BU-12-07DD-00	G 12 x 7 Direct Drive Blower	1
33	3BM-50-ECM0-02	Motor Blower ½ HP ECM Ecotech EMERSON	1
34	1SB-00-BUMR-02	Bracket Long Motor Mounting Direct Drive Blower	1

10. START-UP TEST RESULTS

Model: _____ Serial Number: _____

Date of installation: _____

Installer (name & address): _____

START-UP TEST RESULTS

Size of unit (Btu/h): _____

Nozzle: _____ Oil Pressure (psi): _____

Burner adjustments: RIELLO **F-3** _____ RIELLO **BF-3** _____

Turbulator: _____

Air Gate: _____

Venting type installation:

Two pipe system _____ Coaxial System _____ Vertical one pipe system _____

Smoke result: #0 _____ TRACE _____

Combustion Results: _____ CO₂ %

_____ Excess air (%)

_____ Efficiency (%)

Ambient temperature: _____ °F

Gross flue temperature: _____ °F

Temperature rise: _____ °F (see page 30)

External total static pressure: _____ " W.C. (see page 30)

A/C Coil total resistance: _____ " W.C. (see page 30)

TEST PROCEDURES

External Total Static Pressure Reading

Total Static Pressure = Supply Pressure (Ps) + Return Pressure (Pr)

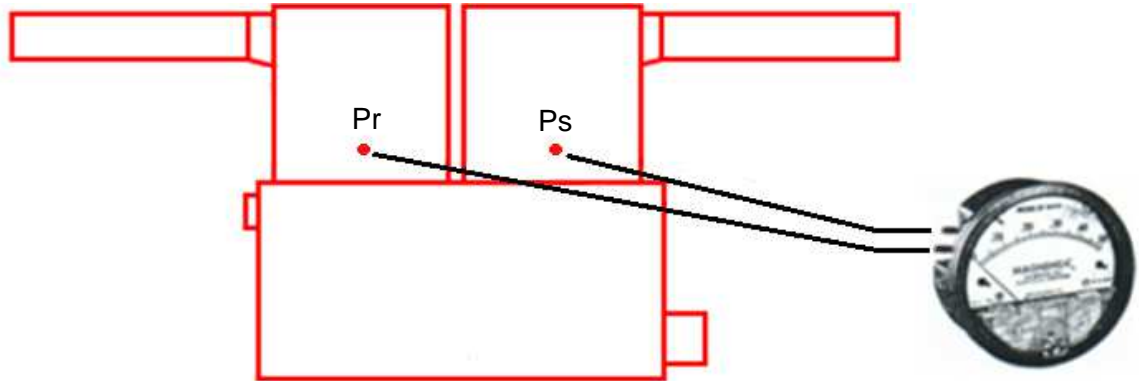

A/C Coil Total Resistance Reading

A/C coil total resistance = Coil Pressure (Pc) - Supply Pressure (Ps)

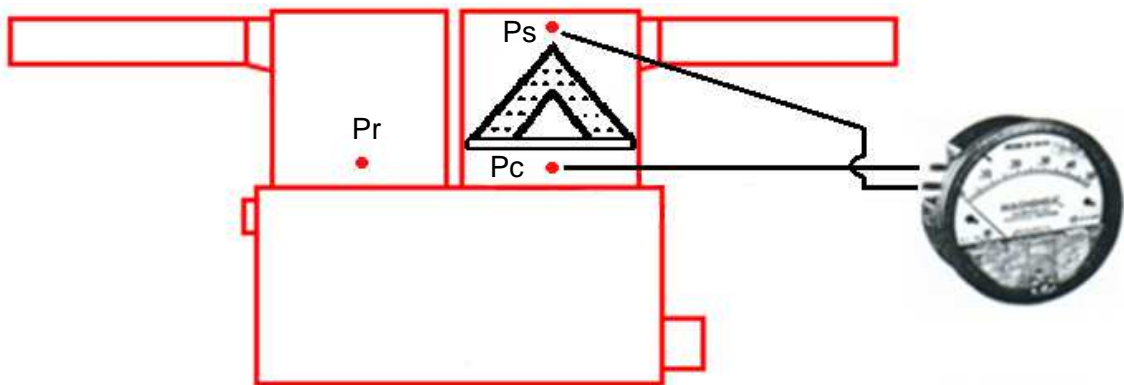

Temperature Rise Reading ***

Temperature rise = Supply Temp. (Ts) - Return Temp. (Tr)

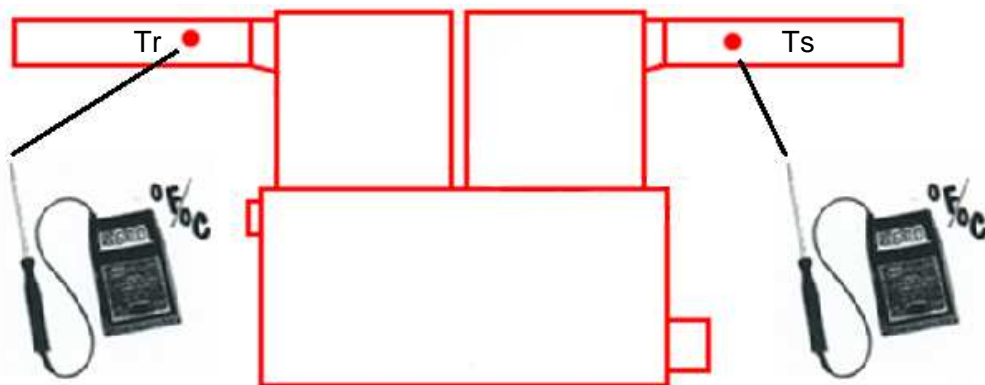

*** Probe must not be in direct sight of heat exchanger.



Granby Furnaces Inc. manufactures a full line of oil-fired furnaces in its 70,000 square feet facility. Granby products are sold across Canada and the United States through a distribution network.

Our team of engineers, designers and technicians continually research and develop products to go beyond the demanding specifications of today's certifications.



Thank you for choosing Granby.