

Series EC™

Oil Boilers



As an ENERGY STAR® Partner, PB Heat, LLC has determined that this product meets the ENERGY STAR guidelines for energy efficiency.

Installation, Operation & Maintenance Manual



PeerlessBoilers.com

TABLE OF CONTENTS

USING THIS MANUAL	1	4. ELECTRICAL	17
A. INSTALLATION CLEARANCE	1	A. GENERAL	17
B. SPECIAL ATTENTION BOXES	1	B. BURNER WIRING	17
1. PREINSTALLATION	2	5. BURNER SETUP & BOILER	
A. CLEARANCES	2	OPERATION	20
B. AIR FOR COMBUSTION & VENTILATION	2	A. BURNER INSTALLATION	20
C. CHIMNEY / VENT & DRAFT CONTROL	3	B. BURNER START-UP & ADJUSTMENT	20
D. INSTALLATION SURVEY	3	C. CHECK THE BOILER CONTROLS	20
E. PLANNING THE LAYOUT	3	D1. FILL THE BOILER (WATER BOILERS)	20
F. BOILER WATER QUALITY & TREATMENT	3	D2. FILL THE BOILER (STEAM BOILERS)	21
G. OIL VENT DAMPER KITS	4	E. PURGE AIR FROM THE SYSTEM (WATER BOILERS ONLY)	21
2. BOILER PLACEMENT & ASSEMBLY	5	F. CLEAN THE BOILER (STEAM BOILERS ONLY)	21
A. SETTING THE BOILER	5	6. MAINTENANCE	23
B. FLUE BAFFLES	5	A. GENERAL	24
C. OBSERVATION COVER ASSEMBLY (KNOCKDOWN BOILERS)	5	B. DAILY MAINTENANCE (WITH BOILER OPERATING)	24
D. INSTALLATION OF FLUE COLLECTORS & COVERPLATES (KNOCKDOWN BOILERS)	5	C. WEEKLY MAINTENANCE (WITH BOILER OPERATING)	24
E. TANKLESS HEATER OR COVERPLATE	5	D. MAINTENANCE OF SAFETY RELIEF VALVE	24
F. JACKET ASSEMBLY	5	E. MONTHLY MAINTENANCE (WITH BOILER OPERATING)	24
G. FLUE COLLAR	6	F. MAINTENANCE – ANNUAL	24
3. PIPING & CONTROLS	8	G. IF A LONG SHUTDOWN IS REQUIRED	25
A. PRESSURE TEST BLOCK ASSEMBLY	8	7. BOILER DIMENSIONS & RATINGS	26
B. BOILER RETURN CLEARANCE	8	8. REPAIR PARTS	28
C. STEAM BOILER PIPING	8		
D. WATER BOILER PIPING	13		
E. TANKLESS HEATER OR COVERPLATE	14		
F. CONTROLS	15		

USING THIS MANUAL

A. INSTALLATION CLEARANCE

Follow the installation instructions provided in this manual in the order shown. The order of these instructions has been set in order to provide the installer with a logical sequence of steps that will minimize potential interferences and maximize safety during boiler installation.

B. SPECIAL ATTENTION BOXES

Throughout this manual special attention boxes are provided to supplement the instructions and make special notice of potential hazards. The definition of each of these categories, in the judgment of PB Heat, LLC are as follows.

DANGER

Indicates a hazardous situation, which, if not avoided, will result in death or serious injury and major property damage.

WARNING

Indicates a hazardous situation, which, if not avoided, could result in death or serious injury and major property damage.

CAUTION

Indicates a hazardous situation, which, if not avoided, could result in minor or moderate injury, and minor property damage.

NOTICE

Indicates special attention is needed, not related to personal injury or property damage.

1. PREINSTALLATION

Read carefully, study these instructions before beginning work. It will save time. Study the included drawings. Save these instructions for reference.

⚠ WARNING

This manual is intended for use by Qualified Heating Professionals only. Installation, service, or adjustment of this heating appliance by anyone other than a Qualified Heating Professional may cause severe personal injury, death, or major property damage.

The boiler warranty can be voided if the boiler is not installed, maintained and serviced correctly.

NOTICE

The equipment shall be installed in accordance with those installation regulations in force in the local area where the installation is to be made, including the current edition of *NFPA-31, Standard for the Installation of Oil-Burning Equipment*, and in *Canada, CSA B139, Installation Code for Oil Burner Equipment*. These shall be carefully followed in all cases. Authorities having jurisdiction shall be consulted before installations are made.

⚠ CAUTION

Never burn garbage or paper in the unit, and never leave combustible material around it.

⚠ CAUTION

Do not tamper with boiler controls.

A. CLEARANCES

Table 1.1: Clearances from Jacket and Vent System

Required from Jacket to Combustible Construction		Recommended From Jacket for Accessibility and Mounting Controls
Top	5"*	24" if Left Side Clearance less than 24" (to clean flueways from top).
Front	16"*	16" from jacket due to burner.
Left	2"*	24" if Top Clearance less than 24" (to clean flueways from left side).
		24" on steam with tankless coil.
		9" in area of boiler service switch and junction box.
Right	2"*	12" due to burner swing radius*.
Rear	2"*	9" for mounting relief valve.
Vent Pipe (Single Wall) - 9" to Combustible Construction. Clearance may be reduced using methods in NFPA 31. Vent Pipe (Double Wall) - See Manufacturer's Instructions.		

* Consider also vent pipe clearance, including distance from edge of flue outlet to combustible construction (as applicable).

Unit may be installed on combustible flooring, provided the boiler is not set on carpet and a metal drip pan is placed under the appliance.

Unit may be installed in a closet with the above clearances. See also Section B, Air for Combustion and Ventilation.

B. AIR FOR COMBUSTION & VENTILATION

1. Be certain adequate facilities are available to provide air for satisfactory combustion and ventilation.
2. Appliances Located in Unconfined Spaces.
 - a. For installation in unconfined spaces with conventional construction and larger areas such as basements, the supply of air for combustion and ventilation can usually be considered adequate.
3. Appliances Located in Confined Spaces.
 - a. All air from inside the building: Provide two permanent openings communicating directly with an additional room. If all air for combustion and ventilation is to come from within the building: two openings, one near the ceiling and one near the floor of the boiler room shall be provided with the minimum free area of each opening equal to 140 sq. in. per gallon of oil burned.
 - b. If all air for combustion and ventilation is to come from outside the building: two openings, one near the ceiling and one near the floor of the boiler room shall be provided with the minimum free area of each opening equal to 35 sq. in. per gallon of oil burned.

If ducts are used to convey the air, areas of 35 sq. in. per gallon of oil burned for vertical ducts or 70 sq. in. per gallon of oil burned for horizontal ducts are to be provided. Ducts shall have the same area as the free area of the openings to which they are connected.

C. CHIMNEY / VENT & DRAFT CONTROL**⚠ WARNING**

This boiler shall be connected to a venting system having sufficient draft. Follow draft requirements below.

Improper venting may result in the release of flue gases which contain deadly carbon monoxide into the home, which can cause severe personal injury, death, or substantial property damage.

1. Draft Requirement - Minimum draft required in the vent system is $-.03''$ W.C. to $-.06''$ W.C. depending on boiler model, see Table 7.1. This draft is necessary to provide the required draft over fire of $-.01''$ W.C. to $-.02''$ W.C..
2. A barometric draft control is required for regulation of over fire draft. Follow manufacturer's instructions to locate and adjust the control.
3. The vent system and installation must be in accordance with the current edition of ANSI/NFPA 211, "Standard for Chimneys, Fireplaces, Vents, and Solid Fuel Burning Appliances"; NFPA-31, "Standard for the Installation of Oil-Burning Equipment" and in Canada, CSA B 139, "Installation Code for Oil-Burning Equipment" or applicable provisions of local building codes. See Table 7.1 for typical chimney size, unless otherwise allowed by code. If the vent system is not sized correctly, the burner may not operate properly. This can cause poor combustion, sooting, and odors to occur.
4. NFPA 31 recommends using a listed metal chimney liner to reduce transient low draft during startup and flue gas condensation during cyclic operation. Any doubt on the condition of a chimney or its ability to prevent the generation and accumulation of flue gas condensate, must be lined according to NFPA 31.
5. Inspect the existing chimney, chimney liner, and vent connector. Make sure each are in good condition and repair or replace as required.

⚠ WARNING

A masonry chimney must have a clay flue liner. If flue gas condensation is occurring, install a listed corrosion resistant metal liner.

Failure to install a clay flue liner may cause severe injury or death.

6. Chimney flue gas condensation is affected by a number of factors such as chimney design, flue connector length, sulfur content in fuel oil, and flue gas temperature. If your application experiences flue gas condensation, installation of a listed corrosion resistant metal liner is required.
 - External chimneys are more susceptible to flue gas condensation due to colder outside air temperatures. To prevent corrosion due to flue gas condensation, use a listed corrosion resistant metal liner in chimney.

- When firing EC(T)-e-03 and 04 section models at 0.75 and 1.25 GPH input rate, respectively, a listed corrosion resistant metal liner is recommended.
- When firing the appliance where fuel oil sulfur content exceeds 300ppm, a listed corrosion resistant chimney liner is recommended.

⚠ WARNING

Series EC™ is approved at listed firing rates only. Failure to fire the boiler at its designed input may cause excessive flue gas condensation and may cause products of combustion to enter the home resulting in severe property damage, personal injury or death.

D. INSTALLATION SURVEY

For new and existing installations, a Water Installation Survey or a Steam Installation Survey is available from P.B. Heat, LLC. The surveys will provide information on how the boiler works with your specific system and will provide an overview of boiler system operation in general.

You can also use this survey to locate system problems which will have to be corrected. To obtain copies of these Surveys, contact your PB Heat representative or download it from PeerlessBoilers.com.

E. PLANNING THE LAYOUT

Prepare sketches and notes of the layout of the installation. Include boiler location, venting system, existing piping and wiring. Show existing equipment that may interfere with installation of new equipment.

F. BOILER WATER QUALITY & TREATMENT

1. Excessive Make-up Water
Leaks in the system must be repaired. Leaks increase the volume of make-up water, which significantly shortens the life of the boiler. Oxygen and chlorides in make-up water greatly accelerate corrosion of the cast iron sections. Minerals in make-up water precipitate when heated and adhere to the cast iron, which eventually overheats the iron and cause the iron to crack. Minerals in make-up water also create foam, which can interfere with proper operation of probe low water cutoffs.
If an automatic water feeder is installed, provide a means of detecting and alerting the user to excessive make-up water, such as a water feed counter.
2. Steam Boilers
 - a. Boiler water pH should be in the 7.5 to 11 range.
 - b. Boiler water chloride concentration should be less than 30 ppm.
 - c. The water hardness should be less than 7 grains per gallon to prevent scale build-up and foaming.

3. Water Boilers
 - a. Boiler water pH should be in the 7.5 to 11 range.
 - b. Boiler water chloride concentration should be less than 30 ppm.
 - c. The water hardness should be less than 9 grains per gallon to prevent scale build-up.

Consult a local qualified water treatment specialist for recommendations regarding the appropriate chemical compounds and concentrations which are compatible with local environmental regulations.

Boiler failure caused by excessive make-up water and poor water quality are not covered as manufacturing defects.

G. OIL VENT DAMPER KITS

Oil Vent Damper Kits are required when boiler is fired at the following additional rates:

EC(T)-e-03-120 and EC(T)-e-04-175

91785: EC(T)-e-03-120 1.20 GPH Input.

91786: EC(T)-e-04-175 1.75 GPH Input.

Each kit includes a Field Controls oil vent damper with blocked vent switch, quick-connect harness, rating label, nozzle, and instructions. Current product literature can be found at PeerlessBoilers.com.

2. BOILER PLACEMENT & ASSEMBLY

A. SETTING THE BOILER

1. Provide a level foundation, located as close as possible to the center of the heating system.
2. Refer to Figure 2.3 for exploded view of boiler while checking and/or assembling parts of the boiler.
3. See clearance information in Section 1, "Preinstallation."
4. On packaged boilers, open burner mounting plate (Item 4) at this time to make certain the target wall (Item 2) is seated in the back of the combustion chamber. Ceramic fiber blanket base liner (Item 3) should be lying flat on bottom of combustion chamber between target wall and burner.

B. FLUE BAFFLES

1. Packaged Boilers - Flue baffles are factory installed.
2. Knock-Down Boilers - Flue baffles are located in jacket cartons. Bend baffle tabs as shown in Figure 2.1 and suspend baffles from top of flueways. Install one baffle per flueway.

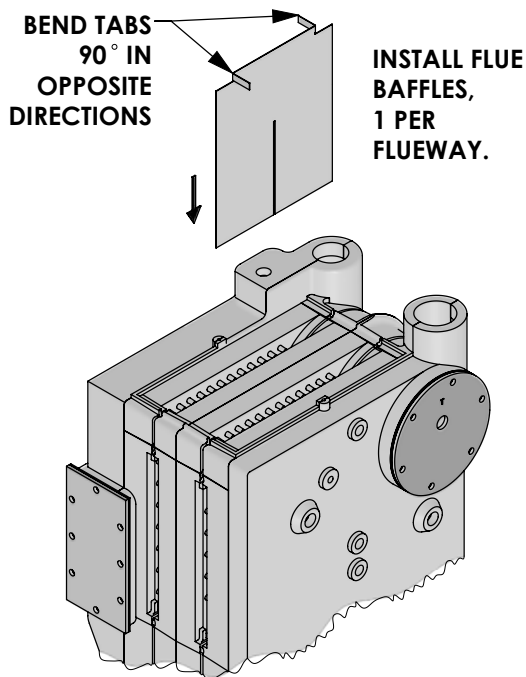

Figure 2.1: Flue Baffle Installation

C. OBSERVATION COVER ASSEMBLY (KNOCKDOWN BOILERS)

1. Remove observation door (Item 6) from inside burner mounting plate. Attach the observation door to the outside of the mounting plate.

D. INSTALLATION OF FLUE COLLECTOR & COVERPLATES (KNOCKDOWN BOILERS)

1. Open flue collector carton. Remove flue collector (Item 13) and high temperature rope. Lay rope (Item 14) on top of boiler against bead provided. Place flue collector on top of rope and attach to boiler with 1/4"-20 x 1-3/4" studs with nuts through flue collector brackets into the tapped lugs provided in the top of the boiler end sections. Draw nuts down snugly.
2. Remove clean-out cover plates and insulation (Items 24 and 25). Each clean-out cover plate is attached to the boiler by using two carriage bolts, nuts and washers (Item 26). Install the carriage bolts into the notch at the top and bottom of each clean-out opening, then secure them with a flat washer and steel nut as shown in Figure 2.2 locking them in place. Press the clean-out plate with insulation over the protruding carriage bolts until the bolts punch through the insulation so flat washer and brass nut can be installed. Tighten down nuts snugly compressing the insulation to form a good seal around the clean-out opening.

E. TANKLESS HEATER OR COVERPLATE

If an ECT steam boiler is to be installed with a tankless heater coil, the coil must be installed before the left side jacket panels are attached. When a tankless heater is not employed, cover the heater opening with cover plate (Item 17 or 21).

See Section 3, Piping and Controls, for piping information.

F. JACKET ASSEMBLY

NOTICE

Be sure rubber gasket is in place between cover plate or water heater plate and boiler section.

1. Refer to Figure 2.3 for exploded view.
2. Attach the back panel to bosses on middle of back section with two 1/4" x 3/8" truss head machine screws (Item 27) provided. The back panel has two 5/16" diameter holes close to the center of the panel.
3. Lift off the burner mounting plate.

BOILER PLACEMENT & ASSEMBLY

4. Insert ceramic fiber blanket base liner (Item 3) on bottom of combustion chamber between target wall and burner. Verify that the target wall is seated in the back of the chamber.
5. Remove the (2) knock-outs in the front jacket panel which allow clearance for the hinge. Place the front jacket panel on the block and replace the burner mounting plate.
6. Attach right side jacket panel to the front and back panels with sheet metal screws (item 28).
7. On steam boilers, if a tankless heater is used, remove the knock out in upper left side jacket panel and back jacket panel before installing. Attach left side jacket panels in the same manner as the right side panel.
8. Attach the top panel. Secure top panel to front and back panel with sheet metal screws.
9. Attach rating label and clearance/burner specification label to jacket. Labels are located in boiler folder which is located in jacket carton.

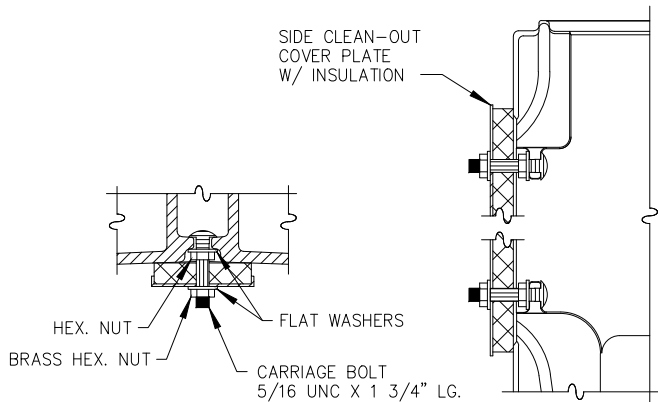

Figure 2.2: Side Clean-out Cover Plates

G. FLUE COLLAR

WARNING

Secure the flue collar to the vent connector and join the sections of the vent connector using sheet metal screws or per listed vent manufacturer's instructions.

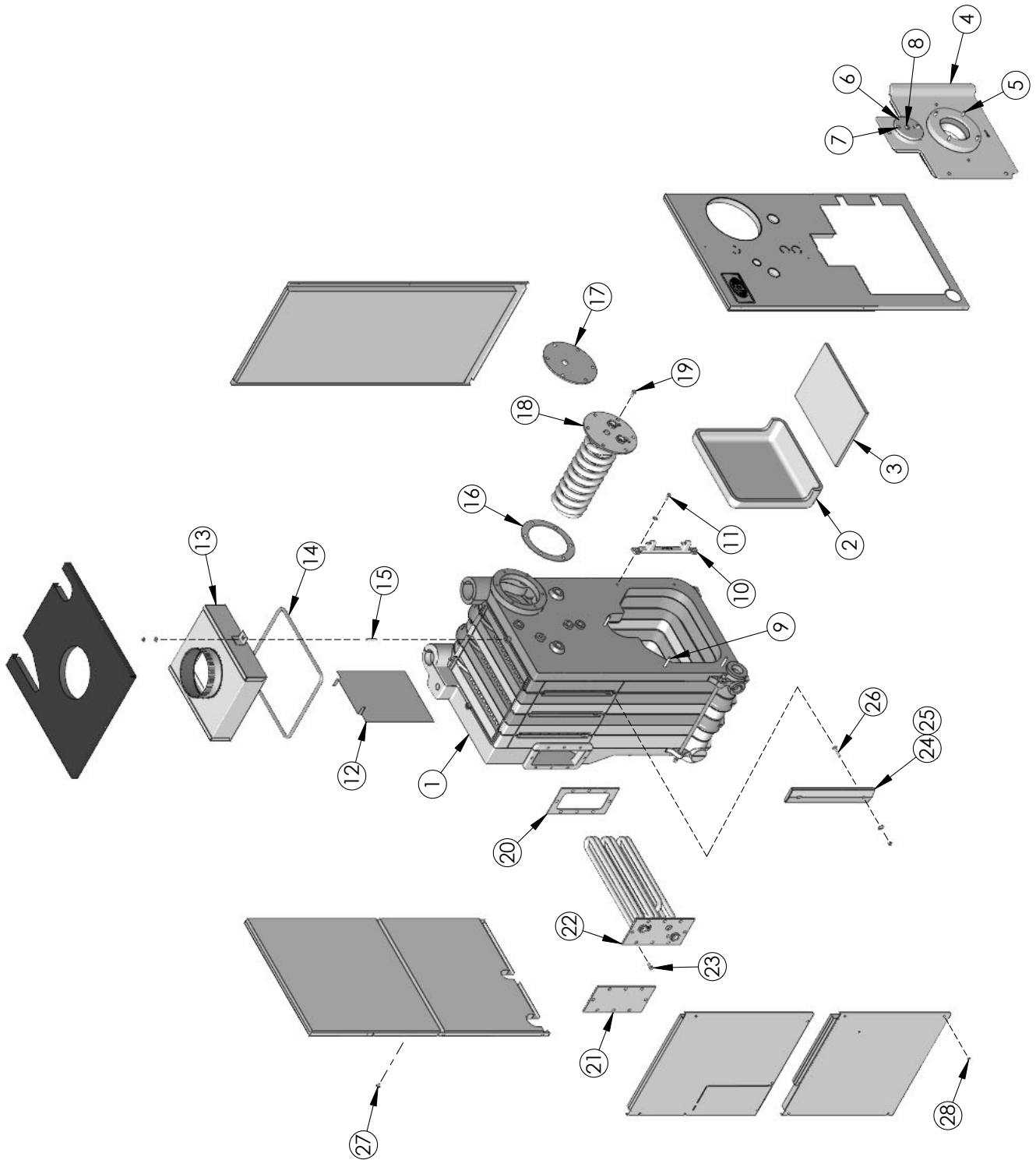

Figure 2.3: Boiler Exploded View
(See Table 8.1 in Section 8 for parts identification).

3. PIPING & CONTROLS

NOTICE

Do not pipe boiler before jacket is installed.

A. PRESSURE TEST BLOCK ASSEMBLY

1. Make up cold water supply connection to the boiler.
2. Install pressure gauge or pressure-temperature gauge in tapping provided. See Boiler Dimensional drawing, Figure 7.1 (Section 7).
3. Plug all open tappings in the boiler and fill with water. Apply approximately thirty (30) psig pressure. Check to make certain that all joints and fittings are water tight.
4. After all joints and connections have been proven tight, remove cold water supply and plugs from all tappings that are to be used. See Figure 7.1 (Section 7) for tapping locations.

B. BOILER RETURN CLEARANCE

Return piping must allow for opening and closing Burner Mounting Plate. PB Heat, LLC suggests installing a 1-1/4 NPT tee, a 90° elbow, and a 1-1/4 NPT x 5" long nipple in the return tapping before a vertical stand pipe is used.

C. STEAM BOILER PIPING

1. Refer to the Steam Installation Survey and Hydronics Institute Residential Hydronic Heating Installation/ Design Guide for guidance.
2. See Figures 3.1 through 3.4. The return from system should always enter equalizer through Hartford Loop, 2" to 4" below normal water line (see dimensional drawing for normal water line).
3. See Table 3.1 for pipe size information.
4. Use swing joints to attach header to avoid damage to the boiler due to thermal expansion and contraction of steam header pipe.
5. Pipe the steam header a minimum of 24" above the normal water line using swing joints to attach the risers into the steam header.

Table 3.1: Steam Pipe Sizing

Boiler Model No.	Risers	Header	Equalizer
EC(T)-e-03-075	1-2"	2"	1-1/4"
EC(T)-e-03-100	1-2"	2"	1-1/4"
EC(T)-e-03-120	1-2"	2"	1-1/4"
EC(T)-e-04-125	2-2"	2-1/2"	1-1/2"
EC(T)-e-04-150	2-2"	2-1/2"	1-1/2"
EC(T)-e-04-175	2-2"	2-1/2"	1-1/2"
EC(T)-e-05-175	2-2"	2-1/2"	1-1/2"
EC(T)-e-05-200	2-2"	3"	1-1/2"
EC(T)-e-06-220	2-2"	3"	1-1/2"
EC(T)-e-06-240	2-2"	3"	1-1/2"

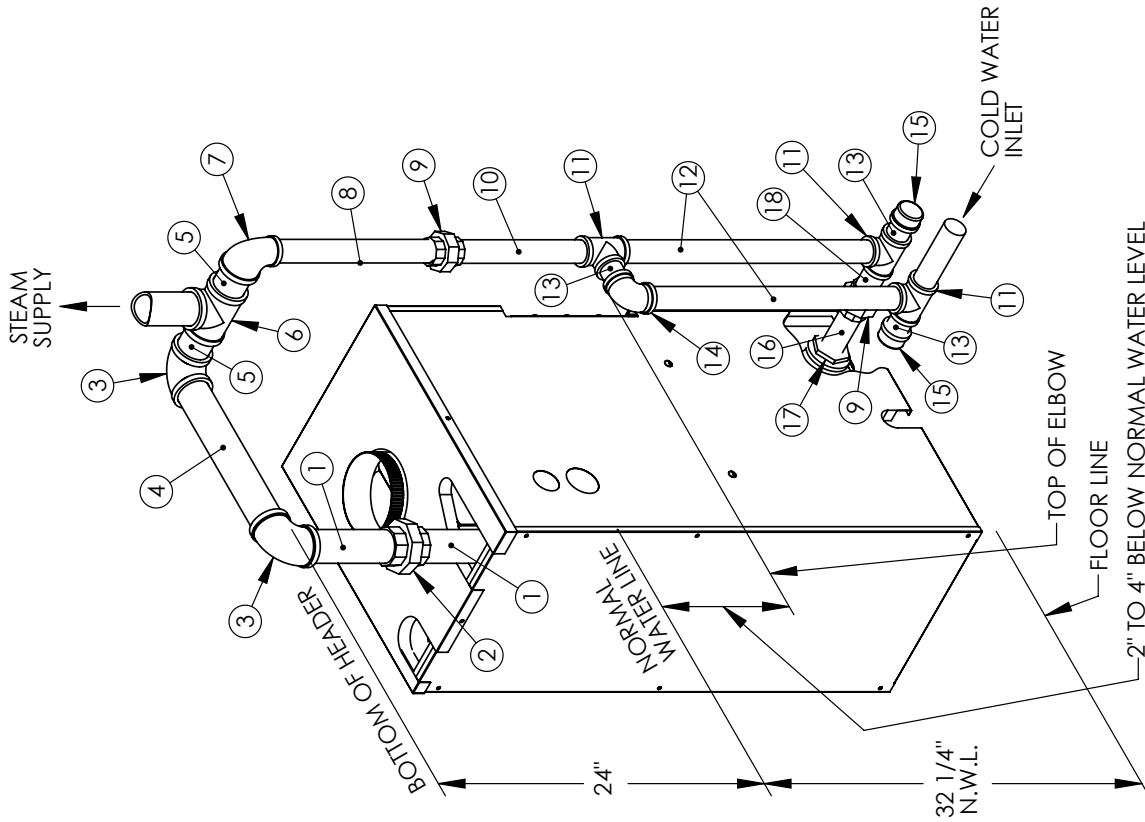

ITEM NO.	DESCRIPTION	QTY
1	NIPPLE - 2 X 8	2
2	UNION - 2	1
3	ELBOW - 2	2
4	NIPPLE - 2 X 14-1/2	1
5	NIPPLE - 2 X 3	2
6	TEE - 2	1
7	REDUCING ELBOW - 2 X 1-1/4	1
8	NIPPLE - 1-1/4 X 14	1
9	UNION - 1-1/4	2
10	NIPPLE - 1-1/4 X 12	1
11	TEE - 1-1/4	3
12	NIPPLE - 1-1/4 X 22-1/2	2
13	NIPPLE - 1-1/4 X 2-1/2 (SHORT)	3
14	ELBOW - 1-1/4	1
15	CAP - 1-1/4	2
16	NIPPLE - 1-1/4 X 4	1
17	HEX BUSHING - 2 X 1-1/4	1
18	NIPPLE - 1-1/4 X 3	1

EC8053 R1

Figure 3.1: Steam; Near Boiler Piping - EC(T)-e-03

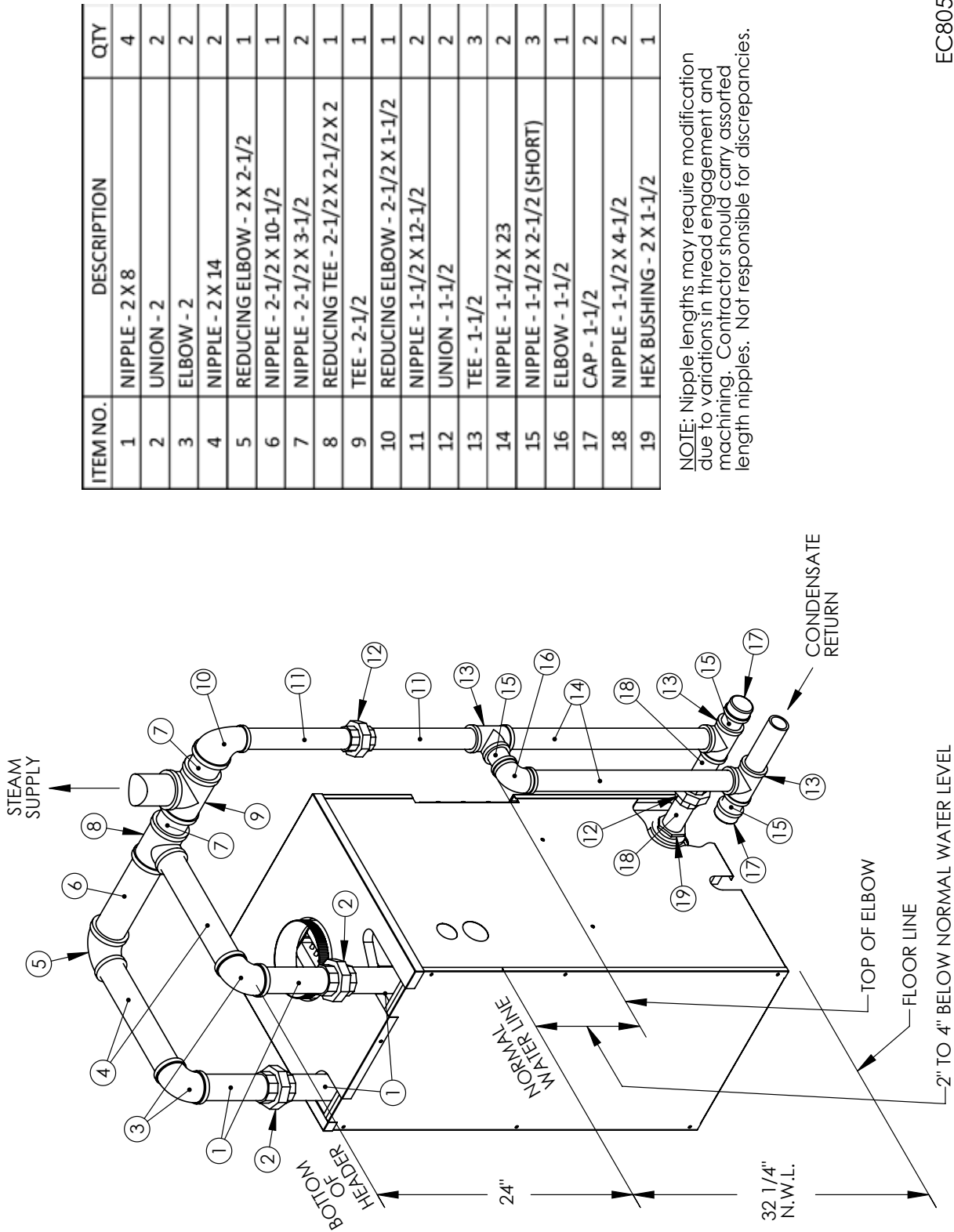

Figure 3.2: Steam; Near Boiler Piping - EC(T)-e-04

ITEM NO.	DESCRIPTION	QTY
1	NIPPLE - 2 X 8	4
2	UNION - 2	2
3	ELBOW - 2	2
4	NIPPLE - 2 X 14	2
5	REDUCING ELBOW - 2 X 2-1/2 (175)	1
6	REDUCING ELBOW - 3 X 2 (200 & 250)	1
7	NIPPLE - 2-1/2 X 14-1/2 (175)	1
8	NIPPLE - 3 X 14-1/2 (200 & 250)	1
9	NIPPLE - 2-1/2 X 3-1/2 (175)	2
10	NIPPLE - 3 X 3-1/2 (200 & 250)	2
11	REDUCING TEE - 2-1/2 X 2-1/2 X 2 (175)	1
12	REDUCING TEE - 3 X 3 X 2 (200 & 250)	1
13	TEE - 2-1/2 (175)	1
14	TEE - 3 (200 & 250)	1
15	REDUCING ELBOW - 2-1/2 X 1-1/2 (175)	1
16	REDUCING ELBOW - 3 X 1-1/2 (200 & 250)	1
17	NIPPLE - 1-1/2 X 12-1/2 (175)	1
18	NIPPLE - 1-1/2 X 12 (200 & 250)	1
19	UNION - 1-1/2	2
20	NIPPLE - 1-1/2 X 12-1/2	1
21	TEE - 1-1/2	3
22	NIPPLE - 1-1/2 X 23	2
23	NIPPLE - 1-1/2 X 2-1/2 (SHORT)	3
24	ELBOW - 1-1/2	1
25	CAP - 1-1/2	2
26	NIPPLE - 1-1/2 X 4-1/2 (175)	1
27	NIPPLE - 1-1/2 X 5-1/2 (200 & 250)	1
28	NIPPLE - 1-1/2 X 4-1/2 (175)	1
29	NIPPLE - 1-1/2 X 4 (200 & 250)	1
30	HEX BUSHING - 2 X 1-1/2	1

NOTE: Nipple lengths may require modification due to variations in thread engagement and machining. Contractor should carry assorted length nipples. Not responsible for discrepancies.

EC8055 R2

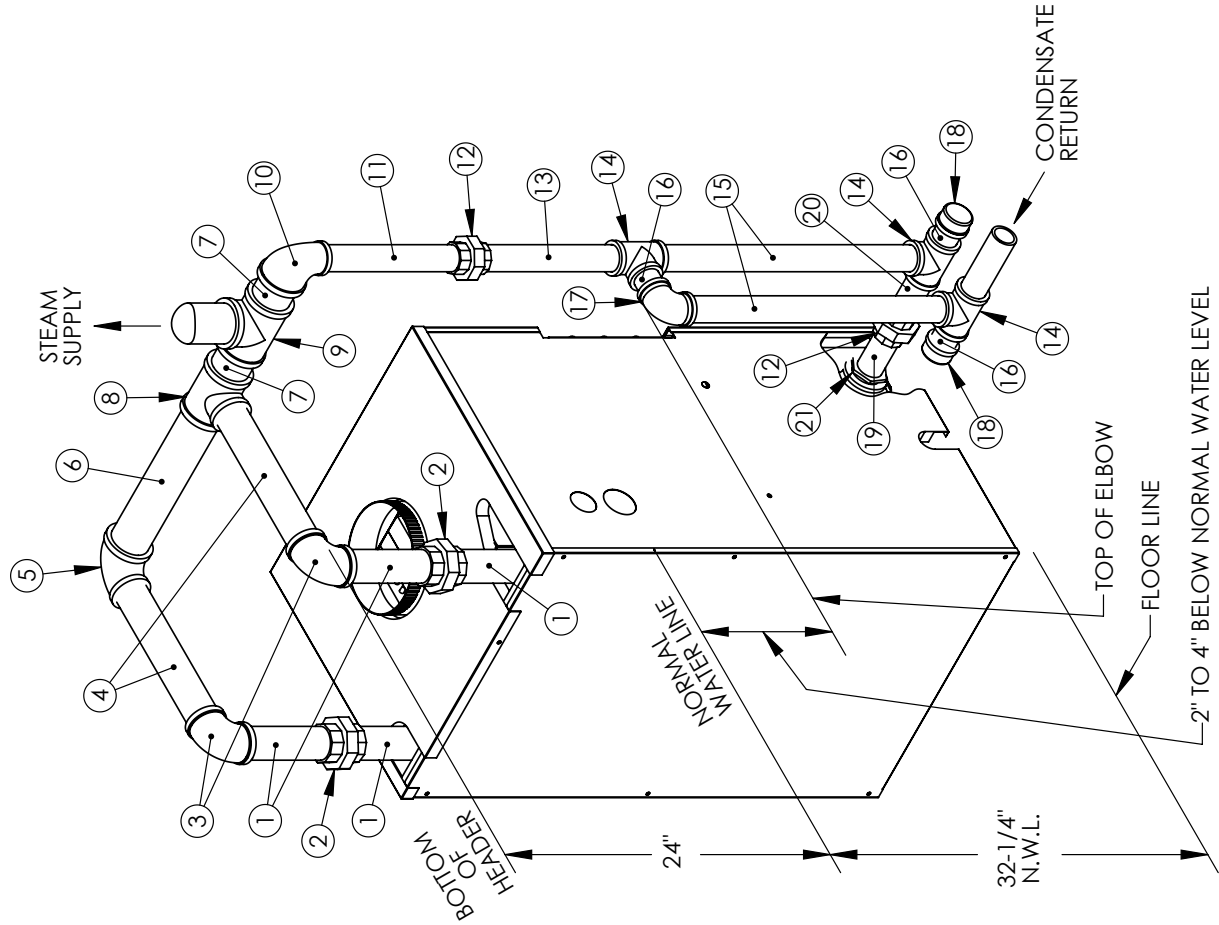

Figure 3.3: Steam; Near Boiler Piping - EC(T)-e-05

ITEM NO.	DESCRIPTION	QTY
1	NIPPLE - 2 X 8	4
2	UNION - 2	2
3	ELBOW - 2	2
4	NIPPLE - 2 X 14	2
5	REDUCING ELBOW - 3 X 2	1
6	NIPPLE - 3 X 18-1/2	1
7	NIPPLE - 3 X 3-1/2	2
8	REDUCING TEE - 3 X 3 X 2	1
9	TEE - 3	1
10	REDUCING ELBOW - 3 X 1-1/2	1
11	NIPPLE - 1-1/2 X 12	1
12	UNION - 1-1/2	2
13	NIPPLE - 1-1/2 X 12-1/2	1
14	TEE - 1-1/2	3
15	NIPPLE - 1-1/2 X 23	2
16	NIPPLE - 1-1/2 X 2-1/2 (SHORT)	3
17	ELBOW - 1-1/2	1
18	CAP - 1-1/2	2
19	NIPPLE - 1-1/2 X 5-1/2	1
20	NIPPLE - 1-1/2 X 4	1
21	HEX BUSHING - 2 X 1-1/2	1

NOTE: Nipple lengths may require modification due to variations in thread engagement and machining. Contractor should carry assorted length nipples. Not responsible for discrepancies.

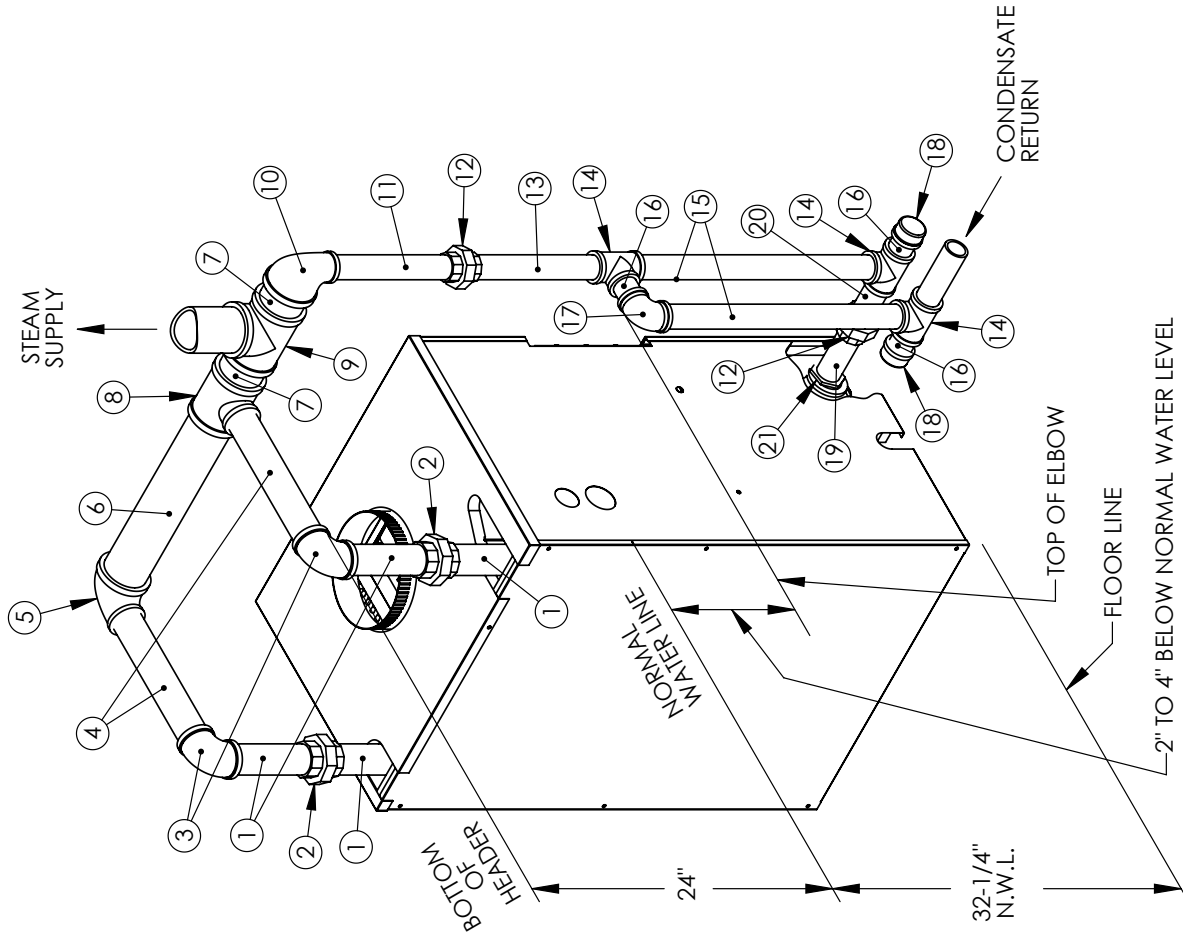

Figure 3.4: Steam; Near Boiler Piping - EC(T)-e-06

EC8056 R2

D. WATER BOILER PIPING

1. Refer to the Water Installation Survey and Hydronics Institute Residential Hydronic Heating Installation/ Design Guide for Guidance.
2. The supply and return connections should be sized to suit the system.
3. Pipe the supply and return in one of two ways as shown in Figure 3.5:
 - a. Pipe the supply from the top of the rear section and return to the bottom of the front section. Use the 3/4" tapping in the top of the back section for air elimination.
 - b. As an alternative, pipe the supply from the top of the front section and return to the bottom of the rear section. Provide air elimination means within the supply piping.
4. When the return temperature from the system will be below 150°F on oil boilers for extended periods (heat pump systems, outdoor reset, snow melt, etc.), provide piping and controls to protect the boiler from condensation. Condensation will damage the boiler and will lead to shortened boiler life and maintenance problems.
5. If using a Partner® indirect fired water heater or other, see Figure 3.6 for typical piping. Also refer to additional instructions supplied with the Partner®.
6. If the boiler is to be used in conjunction with a refrigeration system, the chilled medium shall be piped in parallel with boiler and proper valves applied to prevent the chilled medium from entering the boiler. Refer to Figure 3.7.
7. If the boiler is connected to heating coils located in air handling units, the boiler piping system must be equipped with flow control valves or other automatic devices to prevent gravity circulation of the boiler water during the cooling cycle.

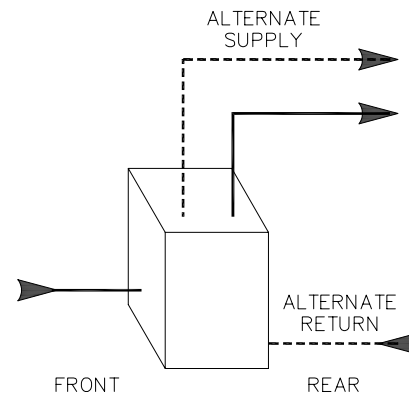

Figure 3.5: Water Boiler Piping

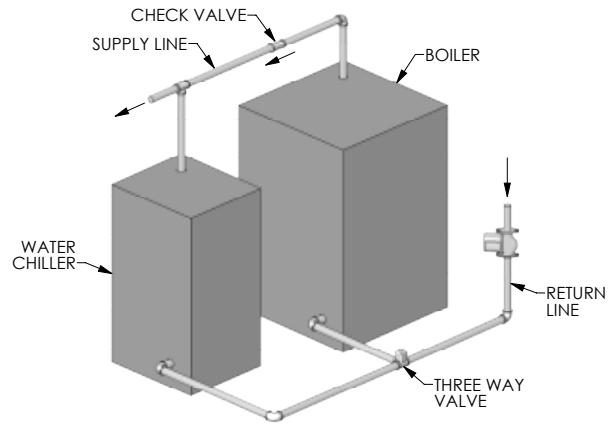

Figure 3.7: Isolating Boiler from Chilled Medium on Chiller Systems

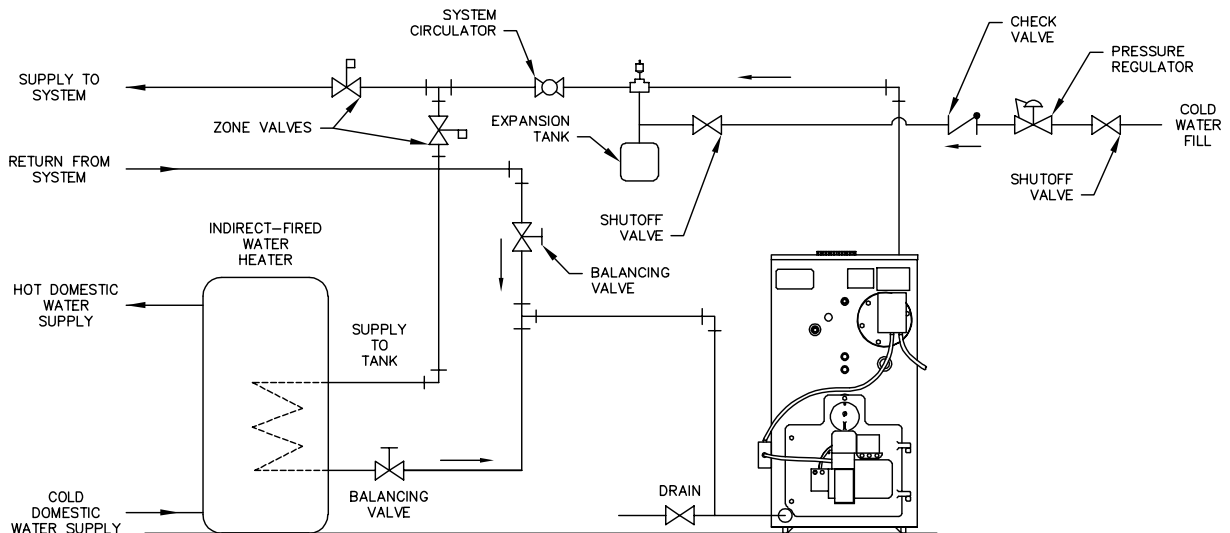

Figure 3.6: Piping with Peerless® Indirect Water Tank

E. TANKLESS HEATER OR COVERPLATE

1. If a tankless coil is used (item 18 or 22), install as pictured. On water boilers, install in opening in front section. On steam boilers, install in opening in rear section. For suggested piping of tankless water heaters refer to Figures 3.8 and 3.9.

⚠ DANGER

Install anti-scald device in hot water supply piping. Water temperature above 125°F can cause severe burns instantly or death from scalds.

2. If not using a tankless coil, cover the heater opening with cover plate (item 17 or 21).

NOTICE

Be sure rubber gasket is in place between cover plate or water heater plate and boiler section.

3. See Table 3.2 for tankless coil ratings.

Table 3.2: Maximum Tankless Water Heater Ratings

Boiler Type	Heater No.	Capacity* GPM
Water (EC)(-e)	X1020	5
Steam (ECT)(-e)	X1082	4

* Water Heater ratings are based on intermittent demand - 40°F to 140°F with 200°F Boiler Water.

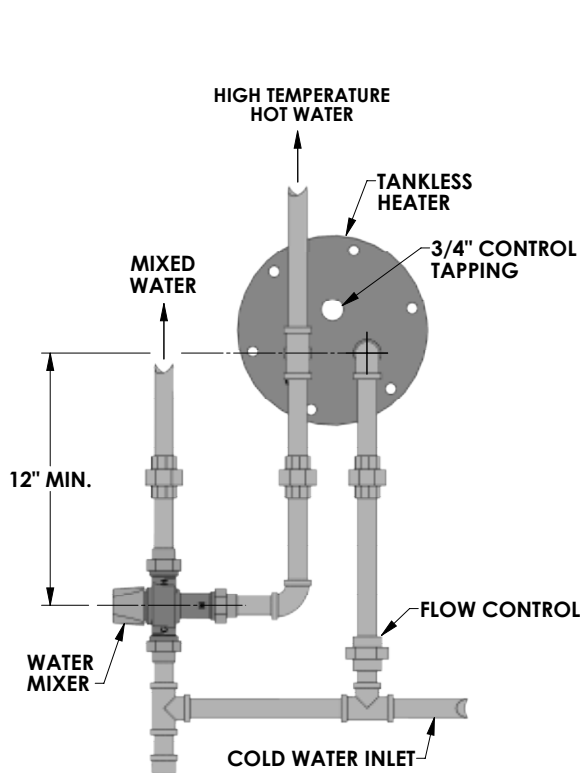

Figure 3.8: Tankless Coil Piping, Water Boiler

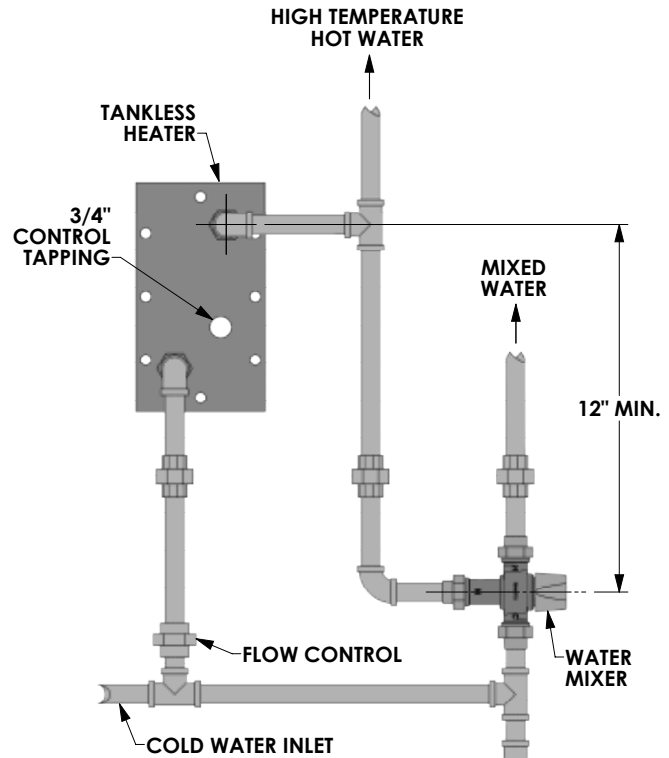

Figure 3.9: Tankless Coil Piping, Steam Boiler

F. CONTROLS

This boiler is equipped with a water temperature limit control which includes a low water cutoff function and also a reset feature as described below.

IMPORTANT NOTICE

In accordance with Section 325 (f) (3) of the Energy Policy and Conservation Act, this boiler is equipped with a feature that saves energy by reducing the boiler water temperature as the heating load decreases. This feature is equipped with an override which is provided primarily to permit the use of an external energy management system that serves the same function.

THIS OVERRIDE MUST NOT BE USED UNLESS AT LEAST ONE OF THE FOLLOWING CONDITIONS IS TRUE:

- An external energy management system is installed that reduces the boiler water temperature as the heating load decreases.
- This boiler is not used for any space heating
- This boiler is part of a modular or multiple boiler system having a total input of 300,000 BTU/hr or greater.
- This boiler is equipped with a tankless coil.

CAUTION

Pipe the discharge of the safety valve or relief valve to prevent injury in the event of pressure relief. Pipe the discharge to a drain. Provide piping that is the same size as the relief valve.

1. Water Boiler Controls:
Install the limit / operating control, pressure-temperature gauge and safety relief valve. See Figure 7.1 (Section 7) for proper location. For installations subject to UL726, a second operating control that senses water temperature is also required (not provided). Use an L4080B or equivalent. Install in the supply piping near the boiler.
2. Steam Boiler Controls:

CAUTION

Failure to maintain boiler water quality could result in a failed heat exchanger.

- a. Steam Boiler with Float Low Water Cut-Off:
Install pressure limit control, pressure gauge, gauge glass trim and safety valve. See Figure 3.10, Figure 3.11, and Figure 7.1 (Section 7). See also control manufacturer's instruction sheet shipped with the control.
- b. Steam boilers with Probe Low Water Cut-Off:

CAUTION

Use only the Hydrolevel CG450 as a primary probe low water. The CG450 includes a cycle timer to sense water level under foaming or surging conditions. Failure to use this model could result in a failed heat exchanger.

Probe models use a longer gauge glass than float models. The following components are packed in the Probe Carton (90759):

- Hydrolevel CG450 LWCO
- Gauge glass 22-212-10
- 3/4" x 3" nipple
- 3/4" x 3/4" x 1/4" tee
- (2) 1/2" couplings



Figure 3.10: Steam Boiler with Float Low Water Cut-Off

Use these components along with the gauge glass handles and other components from the Steam Trim Carton and install fittings and controls per Figure 3.12.

The shorter gauge glass located in the Steam Trim Carton is not for use with the probe application.

- c. Boiler Water Feeders (where used) - See Section 1 - Preinstallation.

d. Steam boilers subject to UL726:

For installations subject to UL726, a second operating control that senses steam pressure is required (not provided). Use a PA404A or equivalent. On probe boilers, install the additional pressure control opposite the standard PA404A using a cross instead of a tee along with a second brass siphon (not provided). On float boilers, install the additional pressure control in the location normally used for the standard PA404A on steam-probe boilers (fittings not provided).

3. For complete information on servicing and adjustment of controls, refer to the attached control specification sheets.

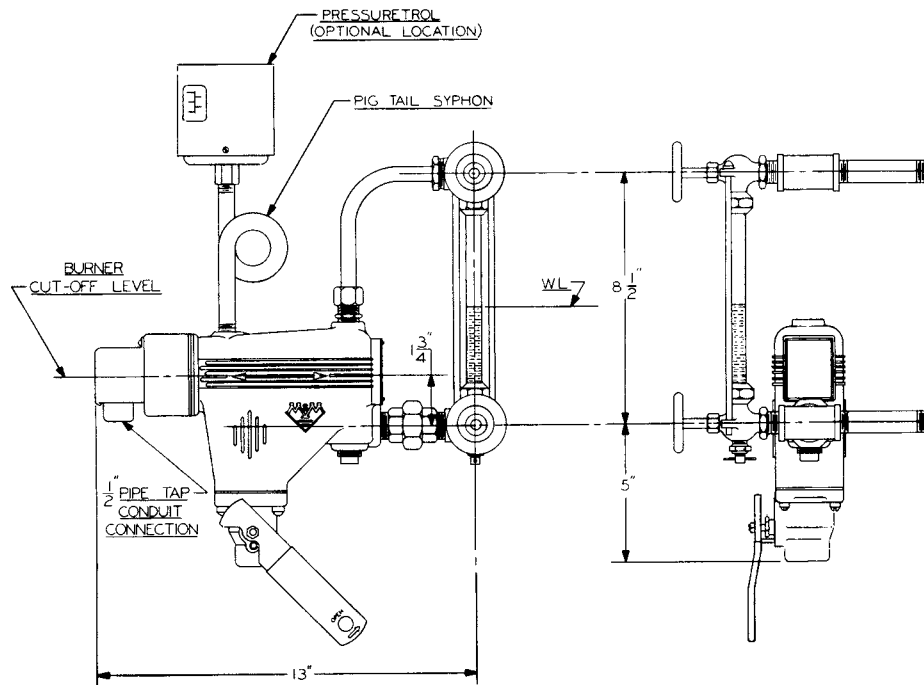

Figure 3.11: Assembling Float Low Water Cut-Off

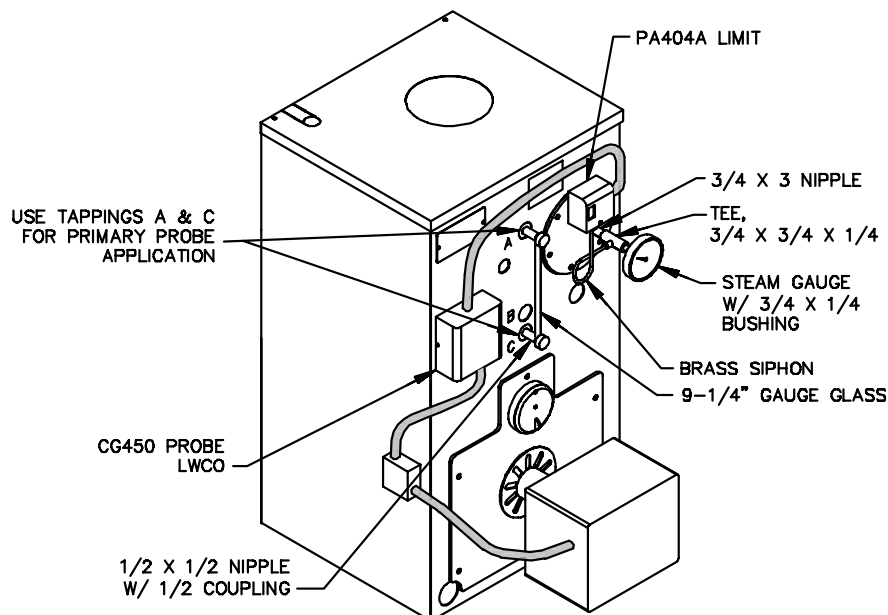

Figure 3.12: Steam Boiler with Probe Low Water Cut-Off

4. ELECTRICAL

A. GENERAL

All electrical wiring shall be done in accordance with the National Electrical Code and Local Requirements. Single pole switches including those of safety controls or protective devices shall not be wired in a grounded line.

B. BURNER WIRING

1. See Section 5 for mounting burner.
2. Install junction box, limit harness, and Heyco bushing, each located in the trim carton. See Figure 4.1. Mount junction box to the holes in the left side of jacket with (2) #10 x 1/2" sheet metal screws. Attach Heyco bushing to 7/8" knockout in front side of junction box. Connect limit harness to 7/8" knockout on top of junction box and insert limit harness Molex connector into Heyco bushing until it snaps firmly in place.

⚠ WARNING

Improper installation of burner harness can allow burner to energize with burner mounting plate open, creating a severe burn hazard to boiler maintenance personnel.

3. For complete information on servicing and adjustment of controls, refer to the attached control specification sheets.
4. See the following Wiring Diagrams:
 - Figure 4.2 - Steam Boilers with Float LWCO
 - Figure 4.3 - Steam Boilers with Probe LWCO
 - Figure 4.4 - Water Boilers with Hydrolevel 3250 Limit Control

NOTICE

If using B100 fuel, post-purge functionality is recommended. Refer to burner manufacturer's manual for post-purge wiring instructions.

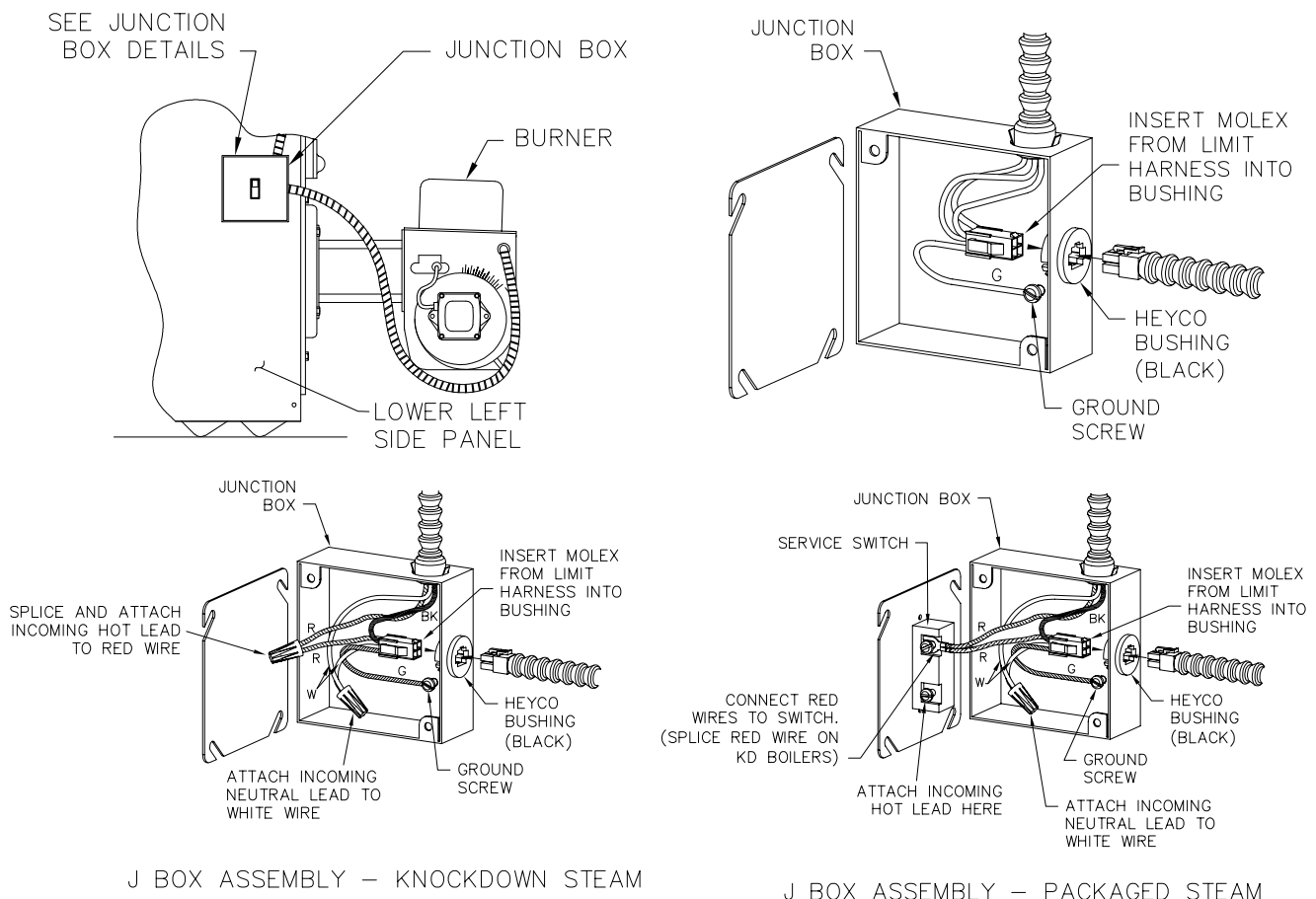

Figure 4.1: Junction Box Wiring and Harness Assembly

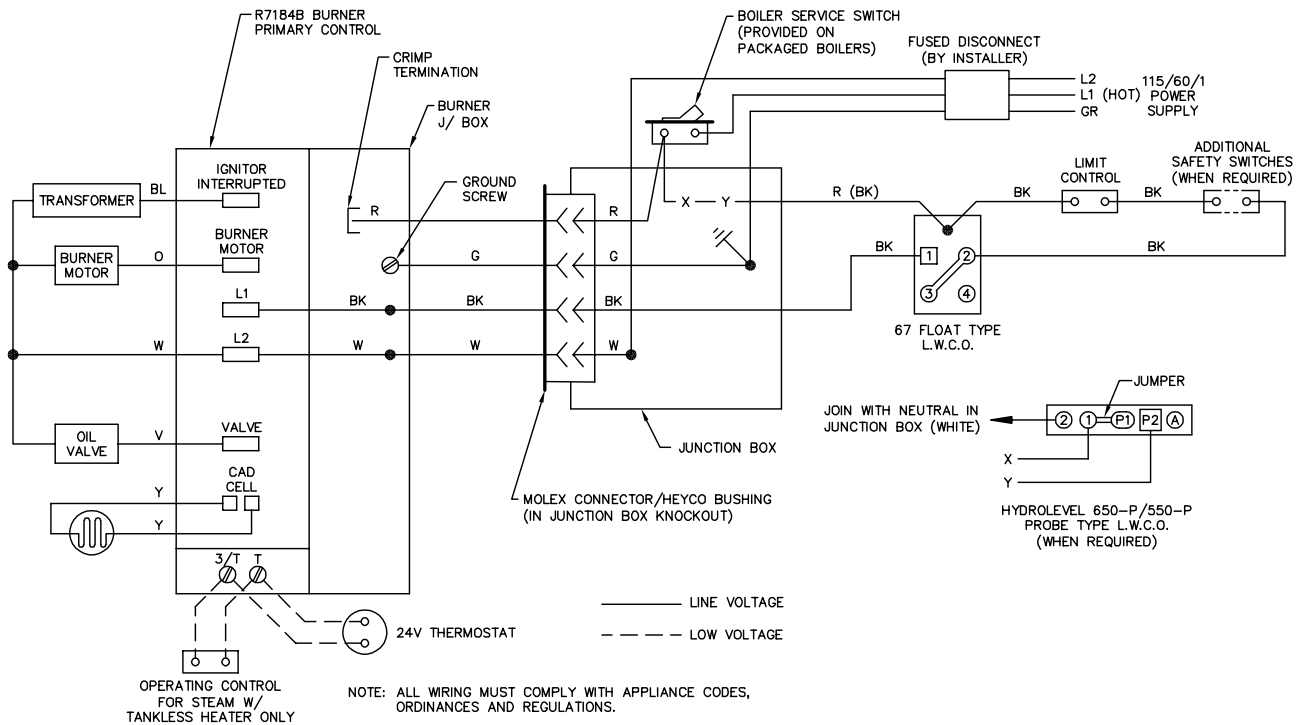

Figure 4.2: Steam Boiler with Float Low Water Cut-Off

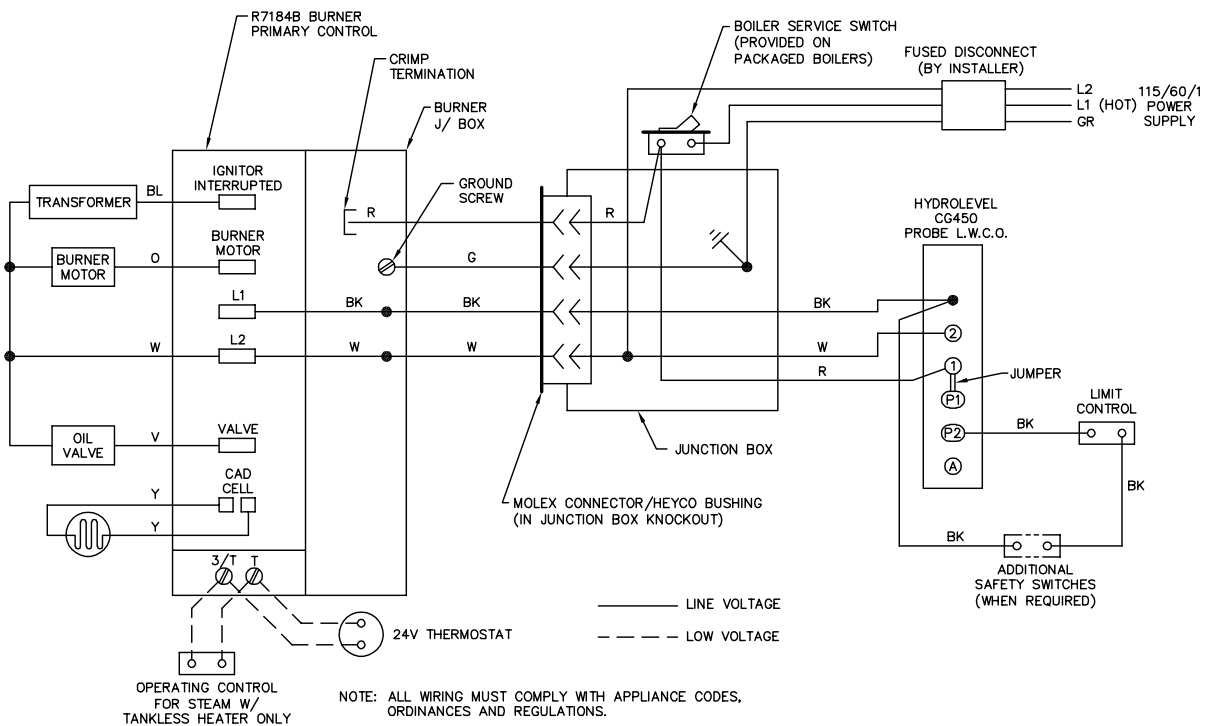

Figure 4.3: Steam Boiler with Probe Low Water Cut-Off

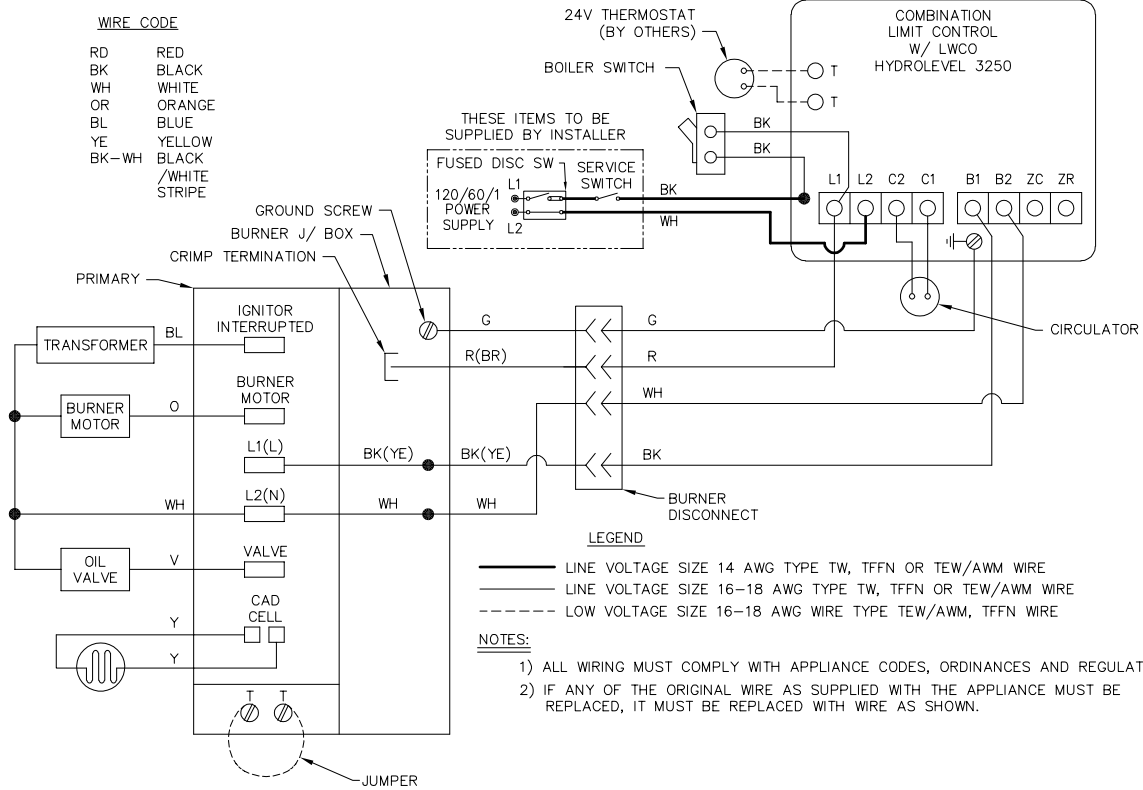

Figure 4.4: Water Boilers with Hydrolevel 3250 Limit Control

5. BURNER SETUP & BOILER OPERATION

CAUTION

Burn only #2 Fuel Oil or #2 Fuel Oil blends containing up to 20% biodiesel. Do not use gasoline, crankcase drainings or any oil containing gasoline.

NOTICE

The maximum biodiesel content in Type 2 oil described in CAN/CGSB-3.2 is 5%. When considering higher blends of biodiesel, careful consideration should be given to cold temperature properties to allow for proper operation of the equipment, especially in areas where colder weather has had historical precedent for the type of fuel selected.

A. BURNER INSTALLATION

1. The oil burner is supplied with a mounting flange fixed in position.
2. Mount the burner to the Burner Mounting Plate (Item 4) with four (4) 5/16" studs and nuts provided.

NOTICE

Be sure hi-temp gasket is between the burner mounting flange and the Burner Mounting Plate.

3. Care must be taken when routing the oil lines so not to interfere with the opening and closing of the burner mounting plate. Flexible oil lines or flared copper disconnects with valves (when copper lines are used) may be installed to ensure full opening of the burner mounting plate when servicing.

NOTICE

Two-pipe oil supply for Riello burner requires a separate kit. Order part #C7001026 from Riello dealer.

4. Oil burner specifications:

For information pertinent to the oil burner such as nozzle sizing, fuel supply piping, adjusting or servicing, refer to Tables 5.1, 5.2, and 5.3 in this section and the burner installation manual.

Riello burners - certain models use common burners across multiple boiler sizes. As required replace installed nozzle with loose nozzle provided and adjust settings.

B. BURNER START-UP & ADJUSTMENT

CAUTION

Do not start the burner unless all cleanout doors are in place.

1. Burner should start automatically when thermostat is turned up and main boiler service switch is turned on. If burner does not start, check to be sure there is oil in the tank and push reset button on burner control:

Beckett: Square red button.

Carlin: Round red button.

Riello: Round red button inside clear flexible cover on back of burner cover.

If burner still does not start, contact serviceman.

CAUTION

Do not attempt to start the burner when excess oil has accumulated, when the unit is full of vapor, or when the combustion chamber is very hot.

2. Adjust burner and barometric draft control for highest CO₂ (Maximum 13.1% [EC(T)-e-03 - EC(T)-e-05] or maximum of 13% [EC(T)-e-06]) while maintaining a 0 Smoke and a minimum of -.01" W.C. draft overfire.

All adjustments must be made using suitable instruments such as found in a Bacharach Combustion Test Kit.

3. Burner and boiler can be shut down by turning down the thermostat and moving the main boiler service switch to the "off" position.
4. See burner manufacturer's manual for further information regarding the burner.

C. CHECK BOILER CONTROLS

1. Limit and Operating Controls:
 - a. Lower the set point of each control until the burner shuts down. Note that the system pressure (or temperature) corresponds to the desired set point.
 - b. Return the controls to the desired set point.
2. Low Water Cut-off - consult the manufacturer's instructions for the low water cut-off operational check procedure.

D1. FILL THE BOILER (WATER BOILERS)

1. Set the air pressure on the expansion tank to the system water pressure before installing. The pressure reducing valve on the fill line will typically allow the system to be filled and pressurized to 12 psi (83 kPa). Consult the valve and expansion tank manufacturer for more specific information.
2. Fill the boiler and system with water making certain to vent air from all high points in the system. Water should bleed from each air vent when it is opened.
3. Check all joints and fittings throughout the system for leaks. If leaks are found, drain the system and repair as required.

4. If the water hardness is high, use water treatment to reduce the deposition of minerals in the boiler.
5. If the water pH is out of 7.5 to 11 range, add water treatment chemicals to bring within range, if required.
6. If the system requires antifreeze protection, use only propylene glycol specially formulated for hydronic systems. These contain inhibitors that prevent corrosion of the boiler and system components. Do not use ethylene glycol or automotive antifreezes.
 - a. Make sure that the antifreeze supplier can provide periodic testing of antifreeze concentration and inhibitor level.
 - b. If an automatic fill valve is used, the solution strength in the system must be checked to assure that the antifreeze concentration has not been overly diluted.
 - c. Local codes may require the addition of a backflow preventer or manual fill only with separation from the city water supply.
 - d. Consider the minimum temperature of potential exposure in the system when deciding on the antifreeze concentration. A concentration of 50% generally provides protection from freezing to -30°F.

D2. FILL THE BOILER (STEAM BOILERS)

1. The normal water line for steam boilers with gravity returns is shown in Figure 7.1.
2. For systems with pumped returns or boilers feed units, the fill level will depend on the control being used. Verify the unit maintains a water level that is visible in the gauge glass and does not exceed the normal water level shown in Figure 7.1.
3. Check all joints and fittings in the system piping for leaks and repair as necessary
4. If the water hardness is high, use water treatment to reduce the deposition of minerals in the boiler.
5. If the water pH is out of 7.5 to 11 range, add water treatment chemicals to bring within range, if required.

E. PURGE AIR FROM THE SYSTEM (WATER BOILERS ONLY)

1. Purge the system using purge valves, isolating zones in the process or use system vents. Do not operate the pump(s) while purging. Pumps will hold air in the eye of the impeller.
2. Allow the system to reach 180°F and use manual vents, if installed, to remove any remaining air. Watch the pressure gauge as the system approaches 180°F. If the pressure exceeds the design operating pressure, check:
 - a. Fill valve pressure.
 - b. Expansion or compression tank operation and sizing.

F. CLEAN THE BOILER (STEAM BOILERS ONLY)

1. Clean the boiler within one week after initial start-up. Cleaning will be more effective if boiler operates a day or two to loosen sediment and impurities in system.

2. Boiler must be cleaned to remove any accumulation of oil, grease, sludge, etc. in the system. These substances can cause foaming and surging of boiler water, producing an unstable water line and water carryover to system.

⚠ WARNING

Cleaning the boiler requires the use of very hot water and corrosive chemicals. Use care when handling to prevent injury.

3. Connect a skim valve off the 1-1/2 NPT skim tapping on rear of boiler. See Figure 7.1 (Section 7) for skim tapping location. Run a 1-1/2 NPT drain line off skim valve to a point of safe discharge.
4. Provide a means of supplying continuous fresh water to the boiler for the cleaning process.
5. Use common washing soda, such as Arm and Hammer Super Washing Soda. Mix 1/2 pound of soda with water in a 10 quart pail. Pour the mixture into the boiler through the safety relief valve tapping.
6. Open the skim valve. Fill boiler until water begins to flow out of the valve.

⚠ CAUTION

Do not leave boiler unattended while firing burner. Operating boiler with water below minimum permissible water level may fracture sections.

7. Turn on burner. Allow boiler water to heat up to just below steaming (180 - 200°F). Do not allow boiler to steam; steaming mixes up contaminants instead of floating them at surface.
8. Open make-up water valve to continually feed water to boiler. Adjust flow to maintain water temperature at 180 - 200°F.

⚠ CAUTION

Do not allow make-up water to flow too fast. Excessive quantities of cold water may fracture sections.

9. Continue skimming boiler until water flowing from skim tapping flows clear. This will take some time, possibly several hours for a dirty system.
10. Turn off burner, close make-up water valve.
11. Drain boiler completely. Refill and drain one or two times to wash out all washing soda.
12. Remove skim valve and piping. Pipe a nipple and cap in the skim valve.

NOTICE

If gauge glass becomes dirty more contaminants have worked loose in system. Repeat cleaning and skimming process as needed to clean system.

BURNER SETUP & BOILER OPERATION

Table 5.1: Beckett Burner Specifications

BECKETT BURNER SPECIFICATIONS (140 psig Pump Pressure)							
Boiler Model No.	Burner Model No.	Burner Head	Static Plate	Nozzle Size	Start-up Settings		Head Setting
					Air Shutter	Air Band	
EC(T)-e-03-075	AFG-L1 ¹	L1 ¹	3-3/8"	0.65 60° B HAGO ³	9.0	2	N/A
EC(T)-e-03-100	AFG-L1	L1	3-3/8"	0.85 60° B HAGO	10.0	1	N/A
EC(T)-e-04-125	AFG-F6	F6	2-3/4"	1.10 80° A DEL ³	5.0	1	N/A
EC(T)-e-04-150	AFG-F6	F6	2-3/4"	1.25 80° B HAGO	8.0	1	N/A
EC(T)-e-05-175	AFG-MV1	M-V1-3	—	1.50 60° B HAGO ³	10.0	3	3
EC(T)-e-05-200	AFG-MV1	M-V1-3	—	1.75 60° B HAGO	10.0	3 *	4 *
EC(T)-e-06-220	CF-375	L1-S	—	2.25 45° P HAGO ³	10.0	6	2
EC(T)-e-06-240	CF-375	L1-S	—	2.50 45° P HAGO	10.0	6	3

* Start-up Head Setting and Air Band Setting updated on EC(T)-e-05-200.

Table 5.2: Carlin Burner Specifications

CARLIN BURNER SPECIFICATIONS							
Boiler Model No.	Firing Rate	Burner Model No.	Air Shutter	Nozzle Size	Pump Pressure	Start-up Settings Air Band	Head Bar
EC(T)-e-03-075	.75	EZ-1HP	Blank	0.60 70° B DEL ³	150 psig	0.55	0.60 - 0.65
EC(T)-e-03-100	1.00	EZ-1HP	Blank	0.85 70° A DEL	150 psig	0.65	0.85 - 1.00
Boiler Model No.	Burner Model No.	Air Shutter		Nozzle Size	Pump Pressure	Start-up Settings	
						Head Dim. A	Air Band
EC(T)-e-04-125	99FRD	Blank		1.00 x 70° B DEL ³	150 psig	2	40% open
EC(T)-e-04-150	99FRD	Blank		1.25 x 60° B DEL	150 psig	3	60% open
EC(T)-e-05-175	99FRD	Open		1.50 x 60° B HAGO ³	150 psig	5	10% open
EC(T)-e-05-200	99FRD	Open		1.65 x 60° B HAGO	150 psig	5	45% open
EC(T)-e-06-220	102CRD	Open		2.25 x 60° B DEL ³	150 psig	6	100% open
EC(T)-e-06-240	102CRD	Open		2.50 x 60° B DEL	150 psig	8	100% open

Table 5.3: Riello Burner Specifications

RIELLO BURNER SPECIFICATIONS								
Burner Model No.	Boiler Size	Boiler Model No.	Firing Rate	Burner Model No.	Nozzle Size	Pump Pressure	Start-up Settings	
							Turbulator	Air Damper
40F5*	03	EC(T)-e-03-075	.75	F5	0.60 60° B DEL ³	155 psig	0.5	2.1
		EC(T)-e-03-100	1.00	F5	0.85 60° W DEL	145 psig	2.0	2.6
	04*	EC(T)-e-04-125	1.25	F5	1.00 60° W DEL ³	155 psig	2.5	3.4
40F10**	04	EC(T)-e-04-150	1.50	F10	1.25 60° B DEL	145 psig	1.5	3.1
	05**	EC(T)-e-05-175	1.75	F10	1.35 60° B DEL ³	165 psig	2.0	2.5
		EC(T)-e-05-200	2.00	F10	1.50 60° B DEL ³	170 psig	2.5	2.8
	06**	EC(T)-e-06-220	2.20	F10	2.25 60° B DEL ³	150 psig	4.0	4.2
		EC(T)-e-06-240	2.40	F10	2.50 60° B DEL ³	145 psig	4.5	4.2

* Riello 40F5 burner is factory set for 03 section boiler. Replace nozzle and update settings when using on 04 section boiler.

** Riello 40F10 burner is factory set for 04 section boiler. Replace nozzle and update settings when using on 05 and 06 section boilers

Factory Installed Nozzles and Factory Start-up Settings (Packaged Boilers or Burner Cartons) are indicated in **Boldface**.

1 Requires Low Firing Rate Baffle.

2 Remove Static Plate for 1.20 GPH Rate.

3 Shipped Loose with Packaged Boiler or Burner Carton.

6. MAINTENANCE

WARNING

Product Safety Information Refractory Ceramic Fiber Product

This appliance contains materials made from refractory ceramic fibers (RCF). Airborne RCF, when inhaled, have been classified by the International Agency for Research on Cancer (IARC), as a possible carcinogen to humans. After the RCF materials have been exposed to temperatures above 1800°F, they can change into crystalline silica, which has been classified by the IARC as carcinogenic to humans. If particles become airborne during service or repair, inhalation of these particles may be hazardous to your health.

Avoid Breathing Fiber Particulates and Dust

Suppliers of RCF recommend the following precautions be taken when handling these materials:

Precautionary Measures:

Provide adequate ventilation.

Wear a NIOSH/MSHA approved respirator.

Wear long sleeved, loose fitting clothing and gloves to prevent skin contact.

Wear eye goggles.

Minimize airborne dust prior to handling and removal by water misting the material and avoiding unnecessary disturbance of materials.

Wash work clothes separately from others. Rinse washer thoroughly after use.

Discard RCF materials by sealing in an airtight plastic bag.

First Aid Procedures:

Inhalation: If breathing difficulty or irritation occurs, move to a location with fresh clean air. Seek immediate medical attention if symptoms persist.

Skin Contact: Wash affected area gently with a mild soap and warm water. Seek immediate medical attention if irritation persists.

Eye Contact: Flush eyes with water for 15 minutes while holding eyelids apart. Do not rub eyes. Seek immediate medical attention if irritation persists.

Ingestion: Drink 1 to 2 glasses of water. Do not induce vomiting. Seek immediate medical attention.

A. GENERAL

1. Check pipes adjacent to cold walls or in unheated spaces. Insulate and tape them if necessary to be sure they can't freeze up. Keeping the water moving at all times will reduce the likelihood of freezing.
2. If there is considerable foreign matter in the boiler water, the boiler should be shut down and allowed to cool, then drained and thoroughly flushed out. Drain the boiler at the drain cock. Pipe the drain cock to a suitable drain or containment device (if antifreeze is used). Flush the system to remove remaining matter. See Section 1 - Preinstallation, for boiler water treatment requirements. If there is evidence that hard scale has formed on the internal surfaces, the boiler should be cleaned by chemical means as prescribed by a qualified water treatment specialist.

See Section 1 - PreInstallation, for boiler water quality requirements, and Section 3F - Controls, for the effects of poor boiler water quality on the proper operation of low water cut-offs.

3. There must be no signs of continuous wetness at the chimney. If signs of continuous wetness are observed, a qualified service agency must be consulted to modify the vent configuration to prevent the formation of condensate, which may damage the vent pipe.

WARNING

Do not use this appliance if any part has been under water. Improper or dangerous operation may result. Immediately call a qualified service technician to inspect the boiler and to replace any part of the control system and any control which has been under water.

B. DAILY MAINTENANCE (WITH BOILER OPERATING)

Daily boiler observation can be performed by the owner. If any potential problems are found, a qualified installer or service technician/agency must be notified.

1. Remove any combustible materials, gasoline and other flammable liquids and substances that generate flammable vapors from the area where the boiler is contained. Make certain that the boiler area has ample air for combustion and ventilation and that there are no obstructions to the free flow of air to and from the boiler.
2. Observe general boiler conditions (unusual noises, vibrations, etc.).
3. Observe operating temperature and/or pressure gauge on the boiler. Boiler pressure should never be higher than 5 psi below the rating shown on the safety relief valve. The valve rating can be found on the top of the safety relief valve. Boiler temperature should never be higher than 250°F.
4. Check for water leaks in boiler and system piping. If boiler includes an automatic water feeder, see Section 1 - Preinstallation.

C. WEEKLY MAINTENANCE (WITH BOILER OPERATING)

1. Flush float-type low-water cut-off (if used) to remove sediment from the float bowl as stated in the manufacturer's instructions.

D. MAINTENANCE OF SAFETY RELIEF VALVE

1. Check function and maintain safety relief valve as specified by manufacturer, typically every other month or every month, per the instructions on the tag on the safety relief valve.

E. MONTHLY MAINTENANCE (WITH BOILER OPERATING)

1. Check boiler room floor drains for proper functioning.
2. Test probe type low-water cut-off (if used) by using the Push-to-Test Button.

CAUTION

Turn off power to boiler before adjusting limit control.

3. Test limit by lowering the limit set point until the burner shuts down. When proper operation is confirmed, return the set point to original setting.
4. Follow additional instructions in the Burner Manual for proving the burner component operation.

F. MAINTENANCE – ANNUAL

NOTICE

Entire heating system, including boiler, burner and venting system, must be inspected at least once a year by a qualified heating professional. Boiler is to be cleaned at least once a year.

WARNING

Disconnect all power to the burner before accessing combustion chamber.

1. CLEAN BOILER
 - a. Remove top jacket panel and flue collector (Item 13).
 - b. Remove and clean flue baffles.
 - c. To thoroughly clean the boiler it must be brushed down from the top and/or left side. Alternatively, for limited space or minimum clearance to combustible installations, cleaning the heat exchanger from the combustion chamber side is acceptable. If unit is extremely dirty, it may be necessary to brush from all directions. The target wall is made of a soft ceramic fiber. Care must be taken not to damage this material during cleaning.

- d. Remove any scale or soot from the combustion chamber area by vacuum cleaning or any other available means.
- e. Replace flue baffles (Refer to Section 2.B).
- f. Replace flue collector and close burner mounting plate, making sure all gaskets are in place.
- g. Replace jacket top panel.

NOTICE

Burner mounting plate must be opened to facilitate this operation.

- 2. Inspect venting system.

NOTICE

All cover plates, enclosures, and guards must be maintained in place at all times, except during maintenance and servicing.

- 3. For systems using anti-freeze, the glycol solution should be tested at least once a year and as recommended by the glycol manufacturer.

G. IF A LONG SHUTDOWN IS REQUIRED

- 1. To take boiler out of service if the boiler and system are not to be used when temperatures are below freezing:
 - a. Drain the boiler and system completely and shut off make-up water supply.
 - b. Open main line power disconnect switch to boiler. Remove the fuses or secure the switch so that the power cannot be turned on accidentally.

 **CAUTION**

Always keep the manual fuel supply valve shut off if the burner is shut down for an extended period of time.

- 2. Be certain that the boiler and system are refilled before returning to service.

7. BOILER DIMENSIONS & RATINGS

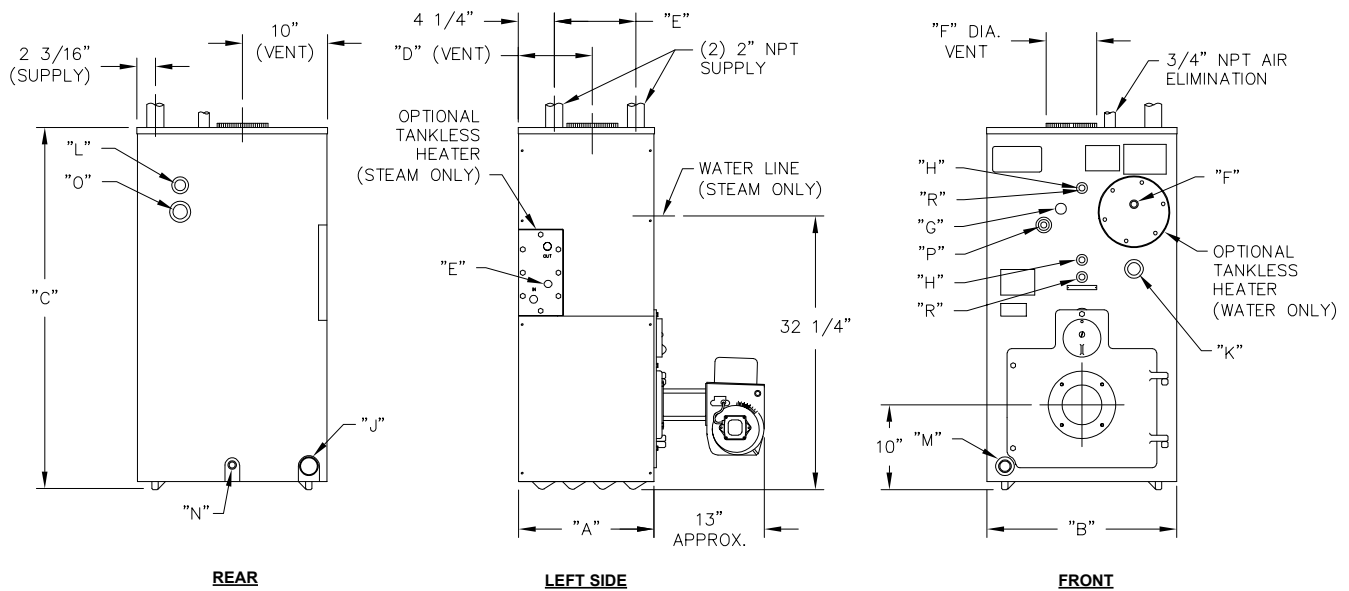

Figure 7.1: Boiler Dimensions / Purpose of Tappings

DIMENSIONS						
Boiler Model	Jacket Depth "A"	Jacket Width "B"	Jacket Height "C"	Rear of Jacket to C/L of Vent "D"	Distance Between Supply Tappings "E"	Vent Size "F" Dia.
EC(T)-e-03	15-3/4"	22-1/2"	42"	8-3/4"	9-1/16"	6"
EC(T)-e-04	19-15/16"			10-7/8"	13-1/4"	7"
EC(T)-e-05	24-1/8"			13"	17-7/16"	8"
EC(T)-e-06	28-5/16"			15-1/16"	21-5/8"	9"

* Dimensions are approximate.

TAPPING LOCATIONS			
Location	Size NPT	Steam	Water
E	3/4"	Low Limit Control	N/A
F	3/4"	Pressure Gauge	Limit Control
G	1/4"	N/A	Temperature-Pressure Gauge
H	1/2"	Gauge Glass and Float LWCO	N/A
J	2"	Return	Alternate Return
K	3/4"	Secondary Probe LWCO	N/A
L	3/4"	Safety Valve	Safety Relief Valve
M	1-1/4"	N/A	Return
N	3/4"	Drain Valve	Drain Valve
O	1-1/2"	Skim Tapping	Optional High Limit
P	3/4"	Primary Probe LWCO	N/A
R	1/2"	Gauge Glass for Primary Probe LWCO	N/A

LWCO = Low Water Cut-off

Table 7.1: Boiler Ratings

Series EC™												Water Content, gal		Min. Stack Draft Reqd.
Model Number	Input		Output ^{3,4} MBH		Net Ratings ²			AFUE, %		Therm. Eff. ⁴ %	Comb. Eff. %			
	USGPH ¹	MBH	Water	Steam	Steam, sqft	Steam, MBH	Water, MBH	Water	Steam					
EC(T)-e-03-075-W/S	0.75	105	93	92	288	69	81	87.6*	86.5	–	–	17.40	14.16	-.03
EC(T)-e-03-100-W/S	1.00	140	122	121	379	91	106	86.5	85.5	–	–	17.40	14.16	-.04
EC(T)-e-04-125-W/S	1.25	175	153	152	475	114	133	86.5	85.4	–	–	21.72	17.28	-.03
EC(T)-e-04-150-W/S	1.50	210	183	181	567	136	159	86.3	85.5	–	–	21.72	17.28	-.04
EC(T)-e-05-175-W/S	1.75	245	215	213	667	160	187	86.8	85.5	–	–	26.04	20.40	-.03
EC(T)-e-05-200-W/S	2.00	280	243	242	758	182	211	86.2	85.0	–	–	26.04	20.40	-.04
EC(T)-05-250-W/S†	2.40	336	279	279	874	210	243	–	–	83.0	85.1	26.04	20.40	-.05
EC(T)-e-06-220-S†	2.20	308	–	259	811	194	–	–	–	84.0	–	–	23.52	-.04
EC(T)-e-06-240-S†	2.40	336	–	282	883	212	–	–	–	84.0	–	–	23.52	-.04
EC(T)-06-275-W/S†	2.75	385	321	321	1006	241	279	–	–	83.3	84.4	30.36	23.52	-.04
EC(T)-06-300-W/S†	3.00	420	347	347	1087	261	302	–	–	82.5	83.7	30.36	23.52	-.05

* As an ENERGY STAR® Partner, PB Heat, LLC has determined that these firing rates meet the ENERGY STAR® guidelines for energy efficiency.

† All chimneys are 8" x 8" x 20' except those models denoted with (†), which are 8" x 12" x 20'.

1 Burner input based on No. 2 fuel oil with a heating value of 140,000 Btu per gallon.

2 Net water ratings based on an allowance of 1.15, net steam ratings based on an allowance of 1.333. Consult Factory before selecting a boiler for installations having unusual piping and pickup requirements, such as intermittent system operation, extensive piping systems, etc.

3 Output is Heating Capacity for models with inputs <300 MBH and Gross Output for models with inputs ≥300 MBH. Heating Capacity and Annual Fuel Utilization Efficiency (AFUE) ratings are based on U.S. Government tests.

4 Thermal efficiency and gross output are determined in accordance with ANSI/AHRI Standard 1500.

Table 7.2: Boiler Ratings - B20

Series EC™ - B20				
Model Number	Input		Output MBH	
	USGPH	MBH	Water	Steam
EC(T)-e-03-075-W/S	0.75	101	85	84
EC(T)-e-03-100-W/S	1.00	135	109	108
EC(T)-e-04-125-W/S	1.25	169	139	138
EC(T)-e-04-150-W/S	1.50	203	170	168
EC(T)-e-05-175-W/S	1.75	237	201	199
EC(T)-e-05-200-W/S	2.00	271	232	231
EC(T)-05-250-W/S†	2.40	325	267	267
EC(T)-e-06-220-S†	2.20	298	248	247
EC(T)-e-06-240-S†	2.40	325	265	270
EC(T)-06-275-W/S†	2.75	372	305	303
EC(T)-06-300-W/S†	3.00	406	329	329

NOTICE

The maximum biodiesel content in Type 2 oil described in CAN/CGSB-3.2 is 5%. When considering higher blends of biodiesel, careful consideration should be given to cold temperature properties to allow for proper operation of the equipment, especially in areas where colder weather has had historical precedent for the type of fuel selected.

8. REPAIR PARTS

Repair parts are available from your local PB Heat, LLC distributor or from Parts To Your Door at 1 (610) 916-5380 (www.partstoyourdoor.com).

Note: Remember to include the boiler model number and serial number when ordering parts.

Table 8.1

	Description	Quantity Required	Stock Code		Description	Quantity Required	Stock Code
1	Block Assembly – EC-e-03	–	90662	14	Flue Collector Rope Seal, 1/2"	7 ft.	51211
	Block Assembly – EC-e-04	–	90663	15	Stud, 1/4-20 x 1-3/4" Lg.	2	51751
	Block Assembly – EC-e-05	–	90657	16	Round Cover Plate Gasket	1	51800
	Block Assembly – EC-e-06	–	90661	17	Round Cover Plate w/ Gasket & Screws	1	99812
	Block Assembly – ECT-e-03	–	90664	18	Tankless Coil – EC WPCT – X-1020-C w/ Gasket & Screws	1	90534
	Block Assembly – ECT-e-04	–	90665	19	Cap Screw, Hex Hd., 3/8-16 x 3/4" Lg.	6	99788
	Block Assembly – ECT-e-05	–	90658	20	Rectangular Gasket (ECT(-e) Models)	1	90547
	Block Assembly – ECT-e-06	–	90660	21	Rect. Cover Plate w/ Gasket & Screws	1	90140
2	Target Wall	–	50768	22	Tankless Coil ECT(-e) SPT – X-1082-C w/ Gasket & Screws	1	90546
3	Base Liner, 1/2" x 14" x 6" (03)	–	50857	23	Cap Screw, Hex Hd., 3/8-16 x 3/4" Lg.	8	99788
	Base Liner, 1/2" x 14" x 10-1/2" (04)	–	50858	24	Side Clean Out Plate Kit, X-1087 (03)	1	50721
Base Liner, 1/2" x 14" x 18-3/4" (05/06)	–	50846	Side Clean Out Plate Kit, X-1087-1 (04)		1	50722	
–	Combustion Chamber Insulation Kit	1	50661		Side Clean Out Plate Kit, X-1087 (05)	2	50721
4	Burner Mounting Plate Assembly for Standard Door	1	93530		Side Clean Out Plate Kits, X-1087 & X-1087-1 (06)	1 each	50721 50722
5	Stud, 5/16-18 x 1" Lg. (Burner to Plate)	4	51748	25	Insulation Board Only for Side Clean Out Plates	1 per flue	50800
–	Burner Mounting Plate Insulation	1	50765	26	Carriage Bolt, 5/16-18 x 1-3/4" Lg.	2 per flue	93997
–	Insulation Hardware for Burner Mtg. Plate	1	95016	27	Machine Screw, Truss Hd., 1/4-20 x 3/8" Lg. (Jacket to Block)	2	91590
–	Burner Mounting Plate Rope, 3/8" MD	6 ft.	55521	28	Screw, #10 x 1/2" Lg., SMS	18	99992
6	Observation Door Round Cover Plate	1	51677	*** JACKETS SOLD ONLY AS ASSEMBLY ***			
7	Machine Screw, 5/16-18 x 3/4" Lg. (To Mount Observation Door)	1	99802	–	EC(T)-e-03	–	90278
8	Machine Screw, 3/8-16 x 1/2" SS (Observation Port)	1	7511	–	EC(T)-e-04	–	90279
9	Stud, 5/16-18 x 2-1/4" Lg. (Plate to Block)	3	51747	–	EC(T)-e-05	–	90280
10	Burner Mounting Plate Internal Hinge	1	3920	–	EC(T)-e-06	–	90281
11	Bolt, Hex Hd., 5/16-18 x 5/8" Lg. (Hinge to Block)	2	91588				
	Flue Baffle - EC(T)-e-03	2	51613				
	Flue Baffle - EC(T)-e-04	3					
	Flue Baffle - EC(T)-e-05	4					
Flue Baffle - EC(T)-e-06	5						
13	Flue Collector & Side Clean Out Assy. w/ Hardware & Rope/Insulation EC(T)-e-03, EC-5000	–	99536				
	Flue Collector & Side Clean Out Assy. w/ Hardware & Rope/Insulation EC(T)-e-04, EC-5000-1	–	99537				
	Flue Collector & Side Clean Out Assy. w/ Hardware & Rope/Insulation EC(T)-e-05, EC-5000-2	–	99538				
	Flue Collector & Side Clean Out Assy. w/ Hardware & Rope/Insulation EC(T)-e-06, EC-5000-3	–	99539				

Part numbers may be subject to change without notice.

Continued on P. 30

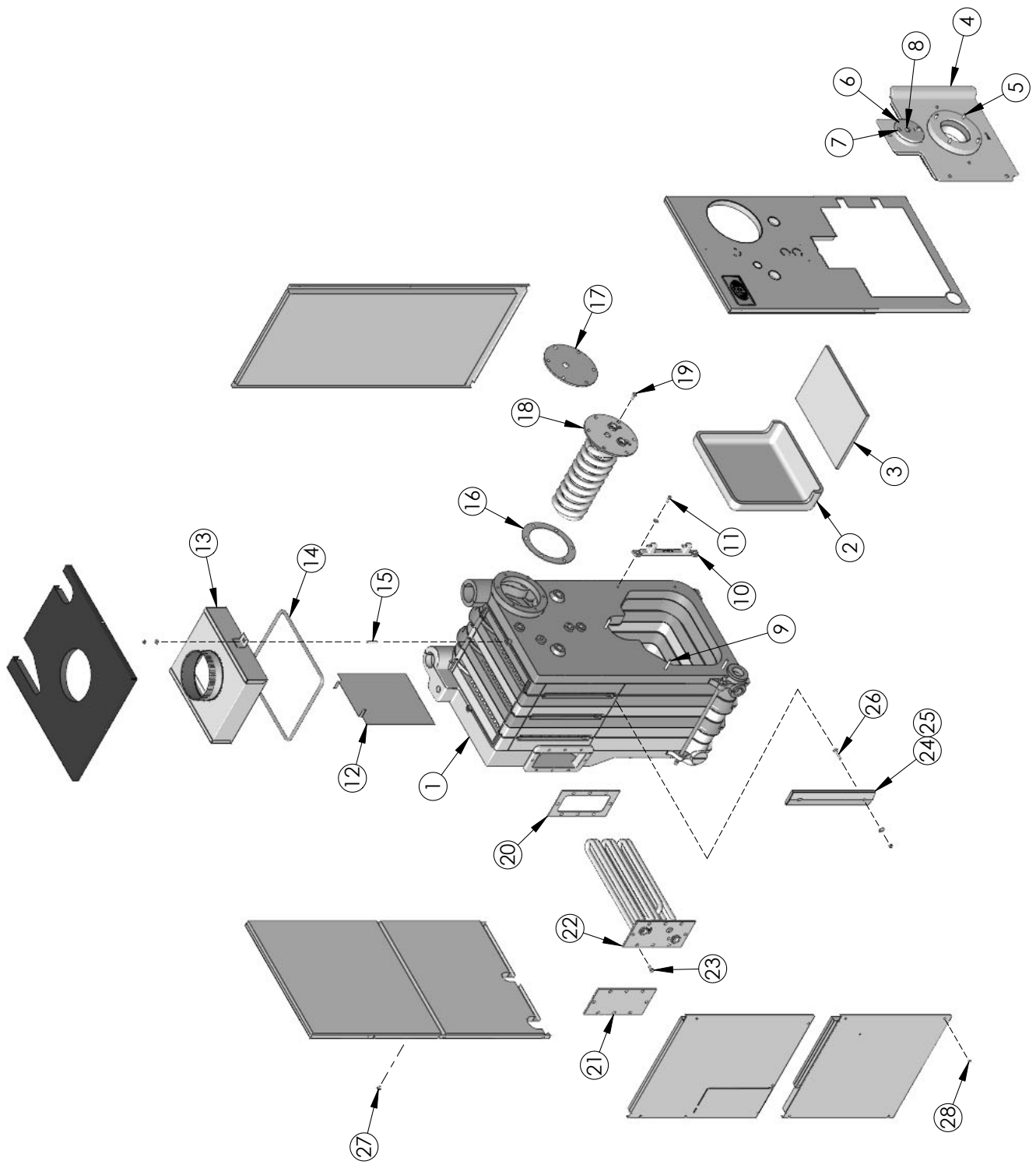

Figure 8.1: Boiler Exploded View

REPAIR PARTS

Table 8.1 (Continued from P. 28)

Item No.	Description	Quantity Required	Stock Code
–	Burner Harness with 4-pin connector, Beckett / Carlin - 21" Lg. Conduit	1	50919
–	Burner Harness with 4-pin connector, Riello - 28" Lg. Conduit	1	50922
–	Heyco bushing at junction box (holds 4-pin connectors) - Steam and KnockDown boilers	1	7957
–	6" Draft Regulator	1	90724
–	7" Draft Regulator	1	90725
–	8" Draft Regulator	1	90726
–	9" Draft Regulator	1	90727
Steam Trim			
–	Pressure Control, PA404A	1	50549
–	Siphon, 1/4" NPT, 90° Brass - Probe Boilers	1	6667
–	Siphon, 1/4" NPT, 180° Brass - Float Boilers	1	6666
–	9-1/4" Gauge Glass, w/ Valves & Rods - Probe Boilers	1	50526
–	7-1/4" Gauge Glass, w/ Valves & Rods - Float Boilers	1	50513
–	LWCO, Hydrolevel CG450, w/ EL1214 Probe - Probe Boilers	1	29041
–	LWCO, McDonnell & Miller 67PE-2 - Float Boilers	1	29003
–	Safety Relief Valve, 3/4"NPT, 15 PSIG	1	50510
–	Pressure Gauge, 2-1/2 RD, 0-30#, 1/4" NPT	1	51325
–	Drain Valve, 3/4" NPT	1	50764
–	Harness, Probe to Junction Box - Package Probe Boilers	1	X7085
–	Harness, Probe to Limit Control - Package Probe Boilers	1	EC7021
–	Harness, Float to Limit Control & Junction Box - Package Float Boilers	1	EC7026
–	Stub harness with 4-pin connector (mates with burner harness at junction box) - KnockDown Steam Boilers	1	EC7025
–	Flue Collector Cover Plate – WBV-04	–	90566
Water Trim			
–	Limit Control, Hydrolevel 3250, w/ Sensor	1	50343
–	Sensor for Hydrolevel 3250, 10" Long	1	54522
–	Well, 3/4" NPT, Long shank, Hydrolevel 48-202	1	50792
–	3/4" Safety Relief Valve, 30 psi	1	50501
–	Temp/Press Gauge, 2-1/2 RD, 320°F, 0-75#, 1/4" NPT	1	51324
–	Drain Valve, 3/4" NPT	1	50764
–	Harness, Limit Control to Burner - Package Water Boilers	1	54511
–	Harness, Limit Control to Jbox/Burner - KnockDown Water Boilers	1	54554
–	Harness, Circulator - Package Water Boilers	1	X7083
–	Switch, Round Toggle, 120 VAC - Package Water Boilers	1	6050

Series EC™

Oil Boilers

Installation, Operation & Maintenance Manual

TO THE INSTALLER:

This manual is the property of the owner and must be affixed near the boiler for future reference.

TO THE OWNER:

This boiler should be inspected annually by a Qualified Service Agency.



PeerlessBoilers.com

PB HEAT, LLC

131 S. CHURCH ST • BALLY, PA 19503

Service Information

Name: _____

Address: _____

Phone: _____

