

INSTALLATION INSTRUCTIONS FOR OPTIMA® SYSTEMS SENSOR ACTIVATED ROYAL® CONCEALED and EXPOSED FLUSHOMETERS

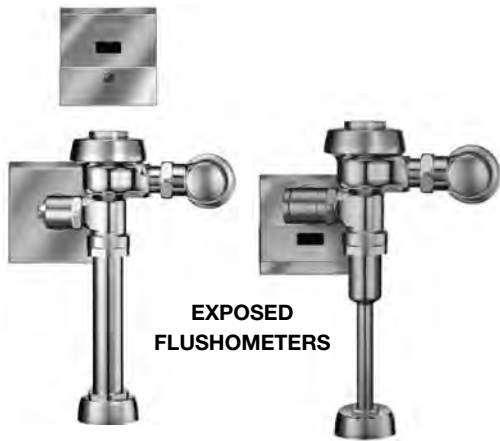

EXPOSED FLUSHOMETERS

CONCEALED FLUSHOMETER



Exposed Closet Flushometers 1½" Top Spud

- Model 110/111 ES-S
- Model 115 ES-S
- Model 116 ES-S

Concealed Closet Flushometers 1½" Rear Spud

- Model 140 ES-S

1½" Top Spud

- Model 153 ES-S

1½" Rear Spud

- Model 152 ES-S

Exposed Urinal Flushometers 1¼" Top Spud

- Model 180 ES-S

¾" Top Spud

- Model 186 ES-S

Concealed Urinal Flushometers 1¼" Rear Spud

- Model 190 ES-S

¾" Rear Spud

- Model 195 ES-S

1¼" Top Spud

- Model 192 ES-S

¾" Top Spud

- Model 197 ES-S



LIMITED WARRANTY

Unless otherwise noted, Sloan Valve Company warrants this product, manufactured and sold for commercial or industrial uses, to be free from defects in material and workmanship for a period of three (3) years (one (1) year for special finishes, SF faucets, PWT electronics and 30 days for PWT software) from date of first purchase. During this period, Sloan Valve Company will, at its option, repair, replace, or refund the purchase price of any product which fails to conform with this warranty under normal use and service. This shall be the sole and exclusive remedy under this warranty. Products must be returned to Sloan Valve Company, at customer's cost. No claims will be allowed for labor, transportation or other costs. This warranty extends only to persons or organizations who purchase Sloan Valve Company's products directly from Sloan Valve Company for purpose of resale. This warranty does not cover the life of the batteries.

THERE ARE NO WARRANTIES WHICH EXTEND BEYOND THE DESCRIPTION ON THE FACE HEREOF. IN NO EVENT IS SLOAN VALVE COMPANY RESPONSIBLE FOR ANY CONSEQUENTIAL DAMAGES OF ANY MEASURE WHATSOEVER.

URINAL - ROUGH-INS

MODEL 180 ES-S

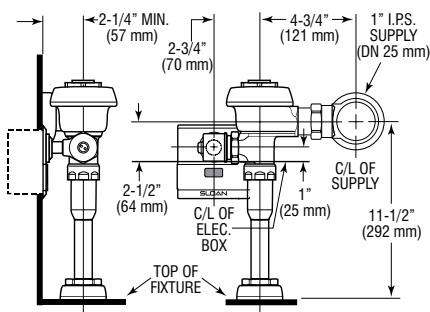

MODEL 186 ES-S

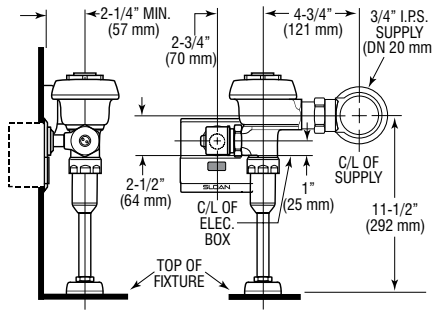

MODEL 190 ES-S

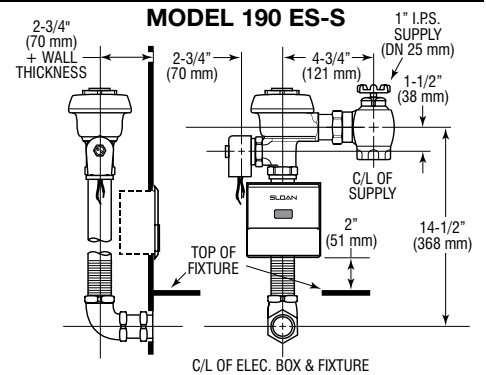

MODEL 192 ES-S

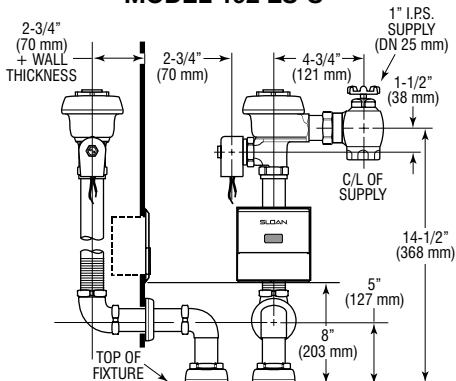

MODEL 195 ES-S

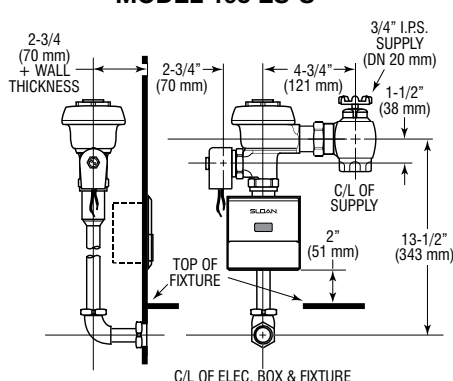

MODEL 197 ES-S

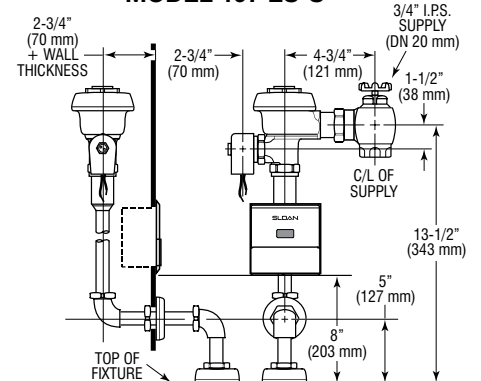

SENSOR LOCATION & POSITIONING IS CRITICAL!

Failure to properly position the electrical boxes to the plumbing rough-in will result in improper installation and impair product performance. All tradesmen (plumbers, electricians, tile setters, etc.) involved with the installation of this product must coordinate their work to assure proper product installation.

WATER CLOSET – ROUGH-INS

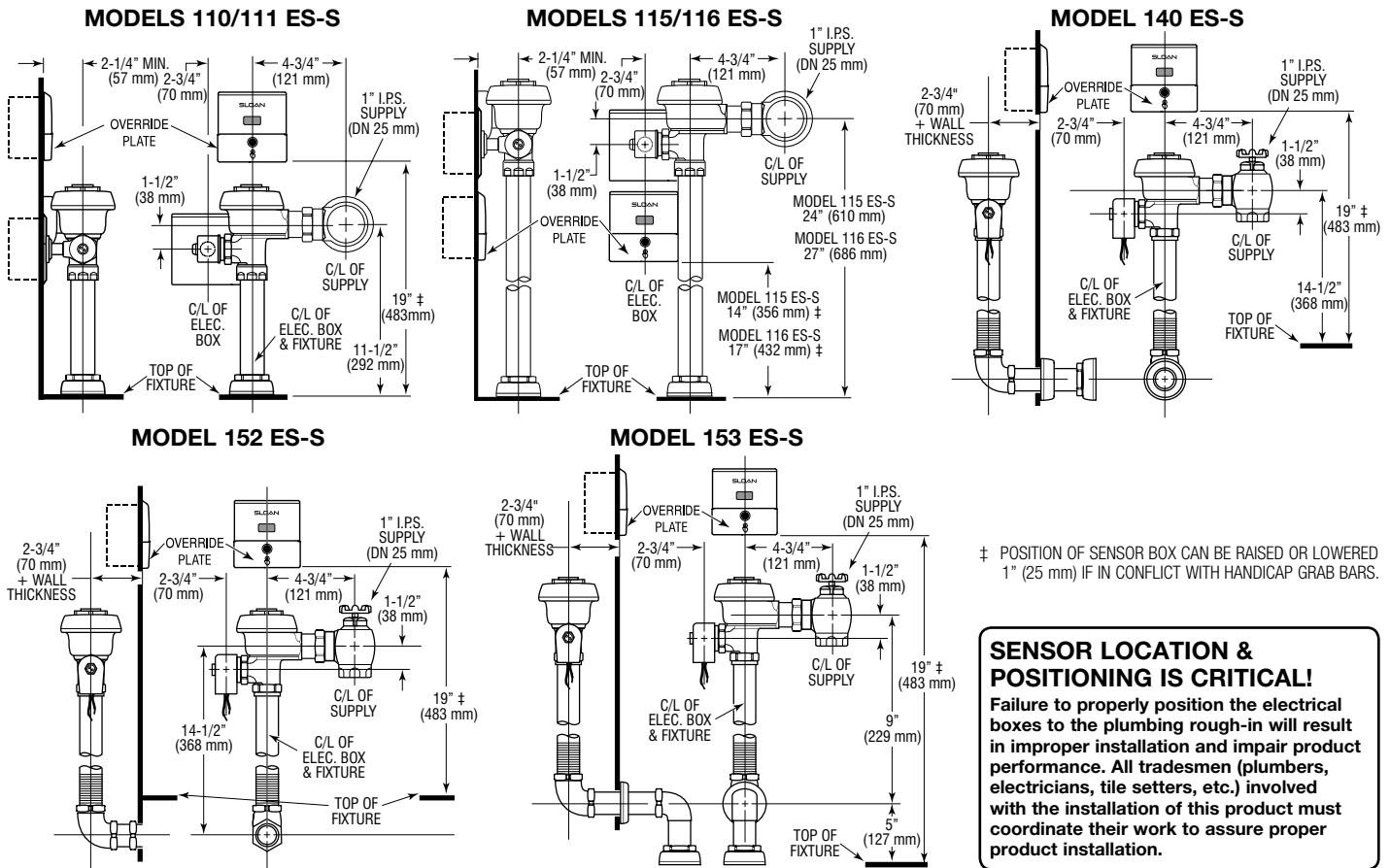

PRIOR TO INSTALLATION

Prior to installing the flushometer, install the items listed below.

- 2-gang electrical box — 4" x 4" x 2-1/2" (102 mm x 102 mm x 64 mm) for sensor; see paragraph entitled "Sensor/Solenoid Operator Box Locations"
- 2-gang electrical box — 4" x 4" x 2-1/2" (102 mm x 102 mm x 64 mm) for transformer; see paragraph entitled "Transformer Installation" (mount in a convenient location)
- Electrical wiring to the transformer box (120 VAC, 2 amp service required for each EL-154, 24 VAC, 50 VA transformer used)
- Urinal fixture
- Drain line
- Water supply line

IMPORTANT:

- **INSTALL ALL ELECTRICAL WIRING IN ACCORDANCE WITH NATIONAL/LOCAL CODES AND REGULATIONS.**
- **INSTALL ALL PLUMBING IN ACCORDANCE WITH APPLICABLE CODES AND REGULATIONS.**

- **WATER SUPPLY LINES MUST BE SIZED TO PROVIDE AN ADEQUATE VOLUME OF WATER FOR EACH FIXTURE.**
- **A 24 VAC STEP-DOWN TRANSFORMER MUST BE USED.**
- **USE APPROPRIATE PRECAUTIONS WHILE CONNECTING TRANSFORMER TO 120 VAC POWER SOURCE.**
- **FLUSH ALL WATER LINES PRIOR TO MAKING CONNECTIONS.**

Sloan flushometers are designed to operate with 15 to 100 psi (104 to 689 kPa) of water pressure. **THE MINIMUM PRESSURE REQUIRED TO THE VALVE IS DETERMINED BY THE TYPE OF FIXTURE SELECTED.** Consult fixture manufacturer for minimum pressure requirements.

Most Low Consumption water closets (1.6 gallon/6.0 liter) require a minimum flowing pressure of 25 psi (172 kPa).

!!! IMPORTANT !!!

NEVER OPEN CONTROL STOP TO WHERE THE FLOW FROM THE VALVE EXCEEDS THE FLOW CAPABILITY OF THE FIXTURE. IN THE EVENT OF A VALVE FAILURE, THE FIXTURE MUST BE ABLE TO ACCOMMODATE A CONTINUOUS FLOW FROM THE VALVE.

!!! IMPORTANT !!!

PROTECT THE FINISH OF THE FLUSHOMETER – DO NOT USE TOOTHED TOOLS TO INSTALL OR SERVICE THESE VALVES. USE A SLOAN A-50 Super-Wrench™, Sloan A-109 Plier Wrench OR SMOOTH JAWED SPUD WRENCH TO SECURE ALL COUPLINGS. ALSO SEE "CARE AND CLEANING" SECTION.

If you have questions about how to install your flushometer, consult your local Sloan Representative or call Sloan Technical Support at:
1-888-SLOAN-14 (1-888-756-2614)

!!! IMPORTANT !!!

THIS PRODUCT CONTAINS MECHANICAL AND/OR ELECTRICAL COMPONENTS THAT ARE SUBJECT TO NORMAL WEAR. THESE COMPONENTS SHOULD BE CHECKED ON A REGULAR BASIS AND REPLACED AS NEEDED TO MAINTAIN THE VALVE'S PERFORMANCE.

TOOLS REQUIRED FOR INSTALLATION

- Slotted screwdriver
- 5/64" hex wrench (supplied)
- Wire stripper/crimping tool
- Sloan A-50 Super-Wrench™, Sloan A-109 Plier Wrench or smooth jawed spud wrench

TRANSFORMER INSTALLATION

Install Transformer (EL-154) on a 2-Gang Electrical Box, 4" x 4" x 2-1/2" (102 mm x 102 mm x 64 mm) in a convenient location; refer to the illustration at upper right side of this page.

Note: One Sloan EL-154 transformer can operate up to ten OPTIMA equipped Flushometers. Run 18-gauge wire from transformer to Flushometer(s). Wire supplied by others. DO NOT supply power to transformer until installation of Flushometer is complete.

Note: A maximum of ten (10) Flushometer units can operate from one (1) Sloan EL-154 Transformer, Class 2, UL Listed, 50 VA (min.) at 24 VAC, plate mounted.

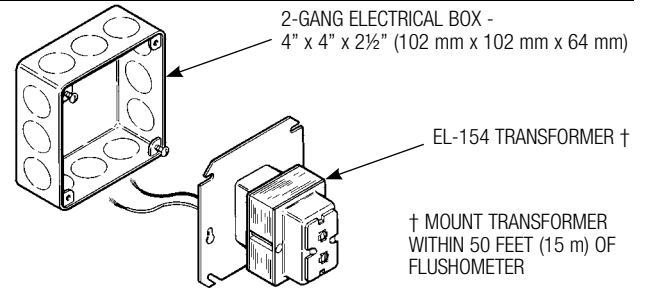

SENSOR/SOLENOID BOX LOCATIONS

Exposed closet models employ two (2) electrical boxes, while concealed closets and exposed/concealed urinal models employ one (1) electrical box. Refer to rough-in illustrations for locations.

ELECTRICAL BOX LOCATION IS CRITICAL — Failure to properly position the electrical boxes to the plumbing rough-in will result in improper installation and impair product performance. All tradesmen (plumbers, electricians, tile setters, etc.) involved with the installation of this sensor activated flushometer must be familiar with the requirements of its installation. Improper installation may void the manufacturer's warranty.

Note: A template is packaged with Models 110/111 ES-S valves to properly position electrical boxes. Refer to rough-in illustrations for installation of electrical boxes.

Note: A template is packaged with Models 180 ES-S and 186 ES-S valves to properly position electrical boxes. Refer to rough-in illustrations for installation of electrical boxes.

Note: Use Appleton #4SD1 Electrical Box and #8470 Plaster Ring or equivalent.

Note: Install plaster ring so screw holes are on left and right side of box.

Note: Break tiles to allow screw holes in plaster to show.

ELECTRICAL BOX INSTALLATION DIAGRAM

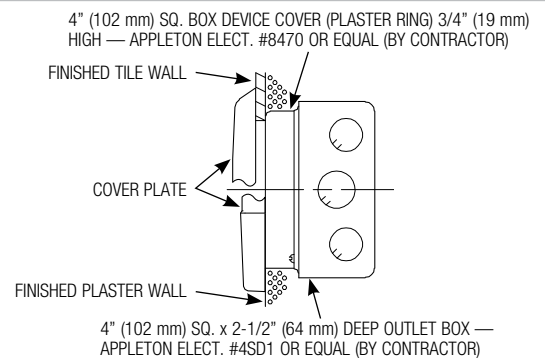
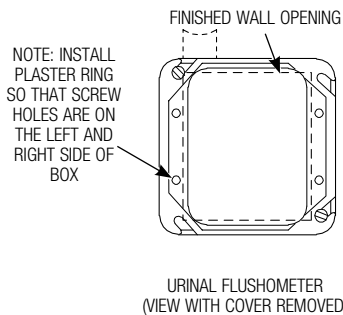

1 - INSTALL OPTIONAL SWEAT SOLDER ADAPTER (ONLY IF YOUR SUPPLY PIPE DOES NOT HAVE A MALE THREAD)

- Measure from finished wall to C/L of fixture spud. Cut pipe 1 1/4" (32 mm) shorter than this measurement. Chamfer O.D. and I.D. of water supply pipe.
- Slide threaded adapter fully onto pipe.
- Sweat solder the adapter to pipe.

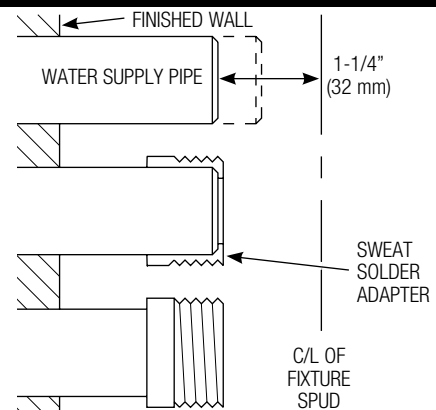

!!! IMPORTANT !!!
WITH THE EXCEPTION OF CONTROL STOP INLET, DO NOT USE PIPE SEALANT OR PLUMBING GREASE ON ANY VALVE COMPONENT OR COUPLING!

2 - INSTALL COVER TUBE, WALL FLANGE AND CONTROL STOP TO SUPPLY PIPE

A Measure from finished wall to first thread of adapter or threaded supply pipe (dimension "X"). Cut cover tube to this length.

B Slide cover tube over pipe. Slide wall flange over cover tube until against wall.

C Thread control stop onto water supply line. Tighten with a wrench making sure outlet is positioned as required.

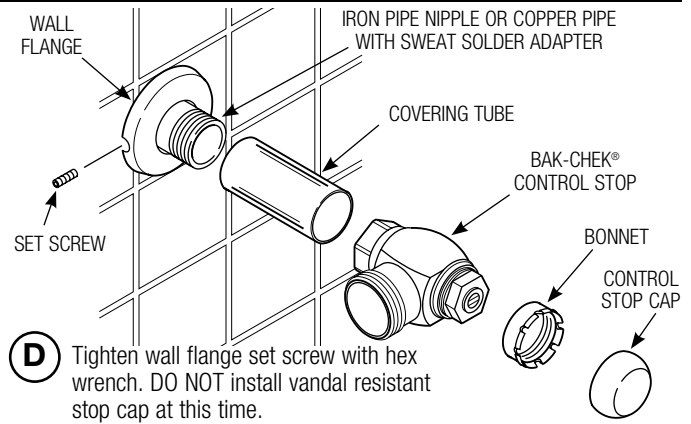
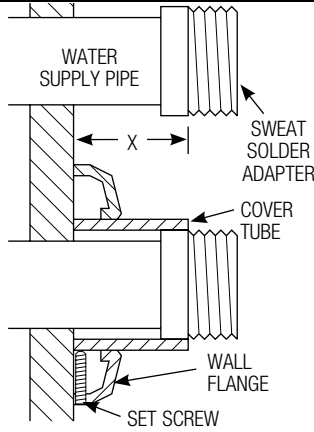

D Tighten wall flange set screw with hex wrench. DO NOT install vandal resistant stop cap at this time.

3 - INSTALL VACUUM BREAKER FLUSH CONNECTION

A Assemble pipe, elbows, couplings, nylon slip gaskets, rubber gaskets and flanges as illustrated.

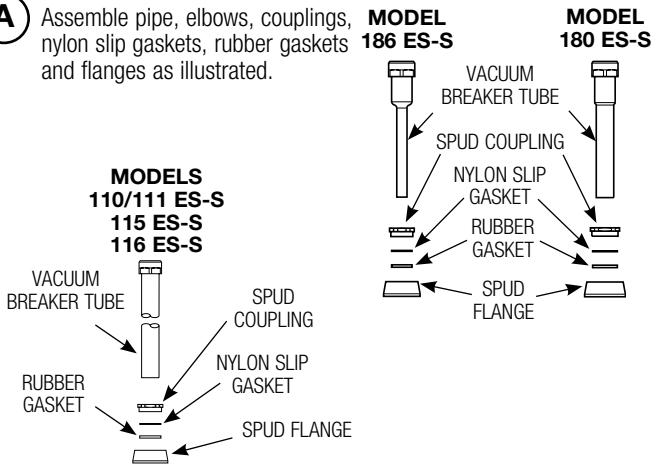

B Insert tube into fixture spud.

C Hand tighten all couplings.

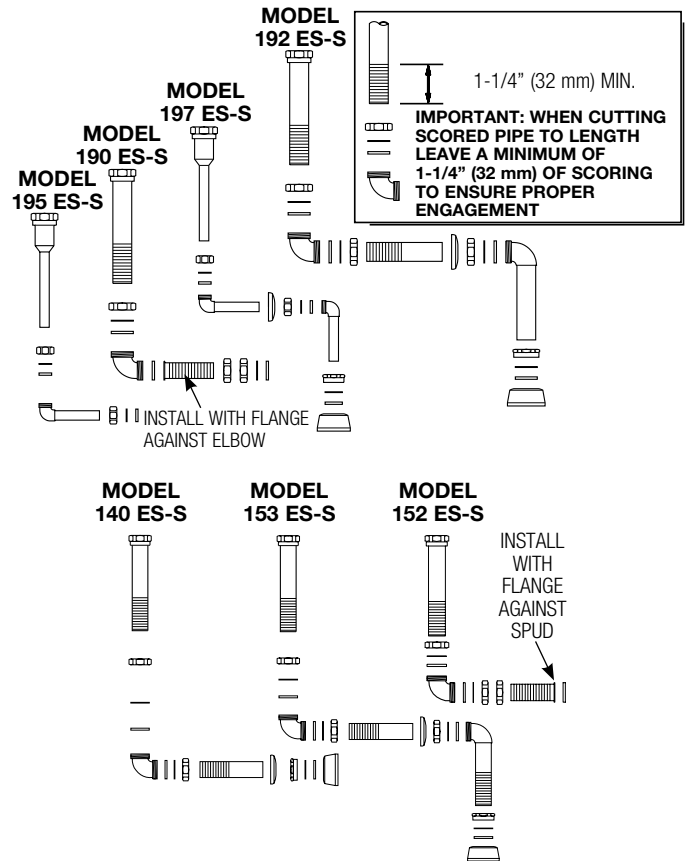

4 - INSTALL FLUSHOMETER

A Lubricate tailpiece o-ring with water. Insert adjustable tailpiece into control stop. Tighten tailpiece coupling by hand.

B Align flushometer directly above the vacuum breaker flush connection by sliding the flushometer body IN or OUT as needed. Tighten vacuum breaker coupling by hand.

C Align flushometer body and securely tighten first the tailpiece coupling (1), then the vacuum breaker and pipe couplings (2), and finally the spud coupling (3). Use a wrench to tighten these couplings in the order shown.

NOTE

Max. adjustment of Sloan Adjustable Tailpiece is 1/2" (13 mm) IN or OUT from the standard 4 3/4" (121 mm) (c/l of Valve to c/l of Control Stop).

If roughing-in measurement exceeds 5 1/4" (133 mm), consult factory for longer tailpiece.

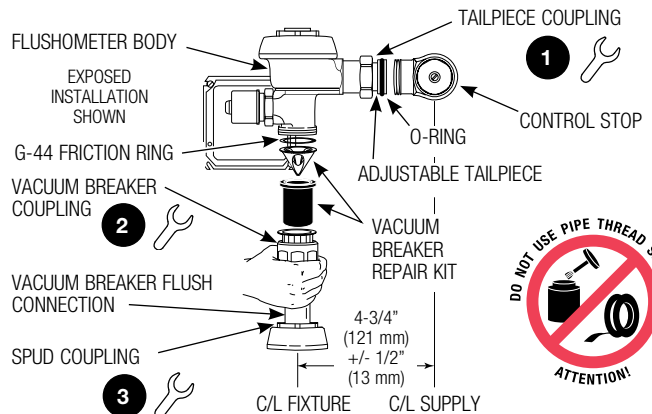

5 - CONNECT SOLENOID OPERATOR

A Exposed Flushometers — To ease installation, remove the solenoid operator from the flushometer; however, prior to removal, read and adhere to the following precautions.

- When removing the coil from the solenoid plunger guide, do so only with the power OFF. Failure to turn power off can result in damage to the sensor, solenoid coil and transformer.
- When removing the solenoid operator from the valve, take care not to damage the o-ring seal on the operator assembly.

B Exposed and Concealed Flushometers — Install mounting plate to electrical box using the screws provided.

C Exposed Flushometers — Slide coil wires through tail and screw tail into solenoid housing. Slide flange assembly and cover plate over tail, respectively.

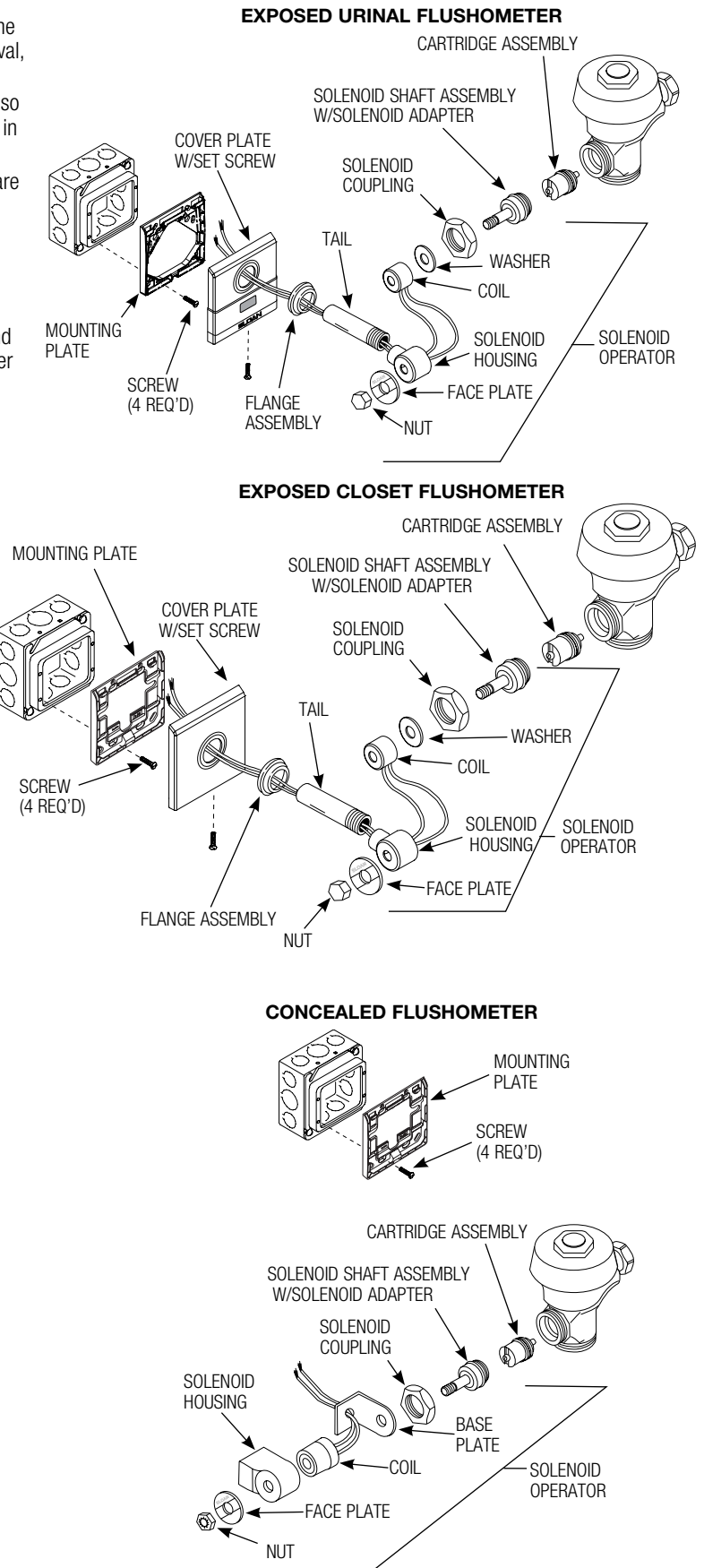

!!! IMPORTANT !!!

DO NOT REMOVE COIL FROM SOLENOID PLUNGER GUIDE UNLESS POWER HAS BEEN DISCONNECTED. FAILURE TO DO SO MAY DAMAGE SENSOR, COIL AND TRANSFORMER.

6A - INSTALL SENSOR BOX MOUNTING PLATE (CLOSET FLUSHMETERS AND CONCEALED URINAL FLUSHMETERS ONLY)

- A** Install sensor mounting plate using the screws provided.

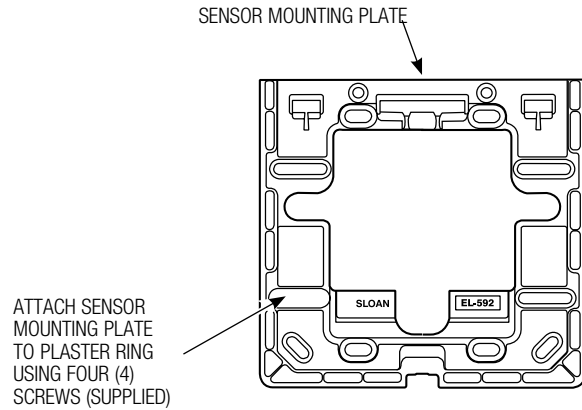

6B - INSTALL SENSOR COVER PLATE, SECURE SOLENOID HOUSING AND COIL ASSEMBLY (EXPOSED URINAL FLUSHMETERS ONLY)

- A** Hang sensor/solenoid cover plate onto mounting plate. Push down on cover plate to firmly seat. Secure cover plate with screw, provided.

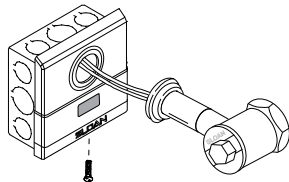

- B** Carefully install solenoid to flushometer while aligning tail to solenoid cover plate. Wet o-ring seal of solenoid operator with water to lubricate. Secure solenoid to flushometer by tightening solenoid coupling. Slide solenoid flange assembly against solenoid cover plate and tighten set screw to tail.

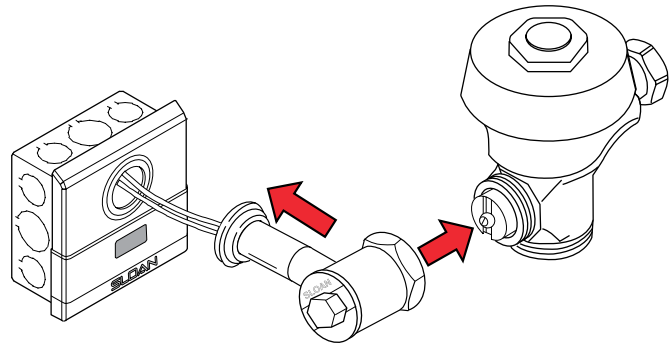

7 - ELECTRICAL HOOK-UP

- A** Be certain power is OFF to prevent damage to electrical components. Connect sensor to transformer and solenoid coil EXACTLY as shown.
- B** Connect 24 volt source lead to terminal labeled "24 VAC IN" of sensor.
- C** Connect solenoid lead to terminal labeled "TO VALVE" of sensor.
- D** Connect remaining solenoid lead to remaining 24 volt source lead.

Wiring Diagram for One Flush Valve

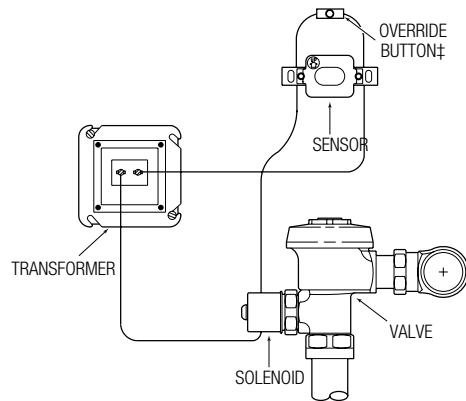

Wiring Diagram for Multiple Flush Valves

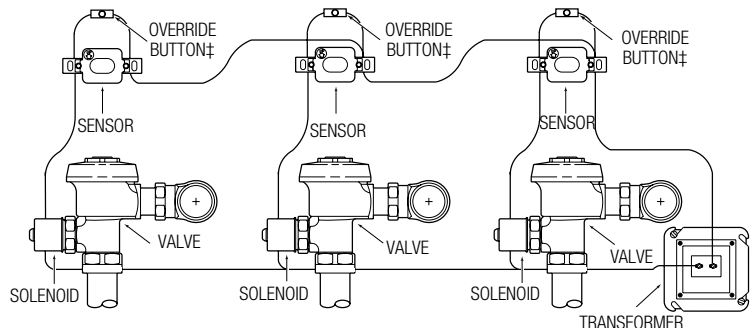

Wiring Diagram

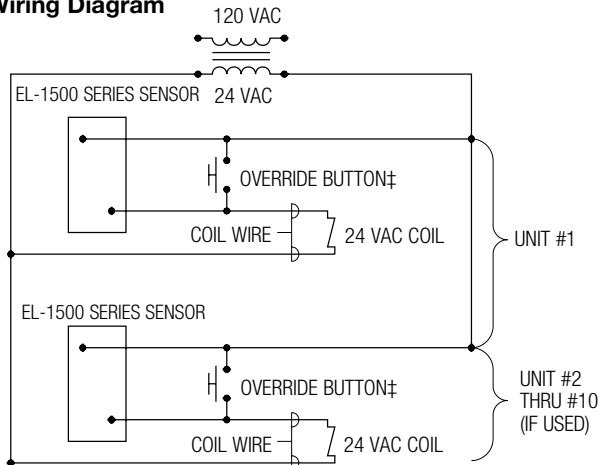

‡ STANDARD ON WATER CLOSETS, OPTIONAL ON URINALS

8 - FLUSH OUT SUPPLY LINE

- A** Make sure control stop is CLOSED.

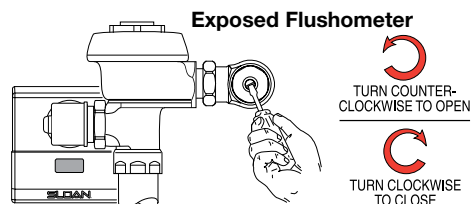

- B** Remove flushometer cover and lift out inside parts assembly. Install flushometer cover wrench tight.

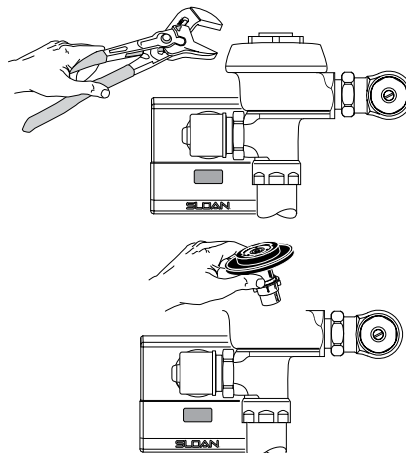

- C** Open control stop. Turn on water supply to flush line of any debris or sediment.

- D** Shut off control stop, remove cover and reinstall inside parts assembly. Install flushometer cover wrench tight. Do not open control stop until Step 11.

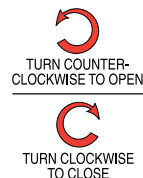

9 - POWER AND START-UP MODE

NOTE: IT IS RECOMMENDED THAT ALL ELECTRONIC CONNECTIONS BE TESTED WITH THE WATER SUPPLY OFF.

- A** Turn power ON. The self-adaptive sensor automatically adapts to the surrounding environment when 24 volt supply is activated. No manual adjustments are required.
- B** Start-up mode will take approximately one (1) minute to complete its cycle and is important that no non-permanent target is present at this time. A continuous red light visible in sensor window indicates sensor is in the start-up mode. If the red light is flashing, this indicates that the sensor is picking up a target. Unless this target is a permanent fixture in the sensor's environment (i.e., a wall or stall door), it must be removed from the view of the sensor. If this target is permanent, the sensor will adapt itself around this target. In that case, disconnect the 24 volt power supply for twenty (20) seconds or more. Reconnect the 24 volt power supply at the transformer or the fuse box. When the start-up cycle is complete, there will be no light visible in the sensor window.
- C** Incorrect wiring or a short in the 24 volt power supply is indicated by a continuous warning signal seen in the sensor window. The visible red light flashes an "SOS" signal: three (3) short flashes, three (3) long flashes, three (3) short flashes.

NOTE: IF 24 VOLT POWER SUPPLY IS INTERRUPTED AT ANY TIME FOR MORE THAN TWENTY (20) SECONDS, THE START-UP MODE AUTOMATICALLY REPEATS ITSELF WHEN POWER IS RESTORED.

10 - DETECTION/ACTIVATION

- A Urinals** – When the sensor detects a user, a slow flashing red light appears in the sensor window. After approximately eight (8) to ten (10) seconds, the light will flash rapidly indicating sensor is armed. When the sensor no longer detects a user, the sensor immediately activates the solenoid after a 0.5 second delay.
- Water closets** – Detection and activation are the same as the urinal except when the sensor no longer detects a user, the sensor activates the solenoid valve after a three (3) second delay.

EXPOSED WATER CLOSET FLUSHOMETERS AND CONCEALED WATER CLOSET/URINAL FLUSHOMETERS

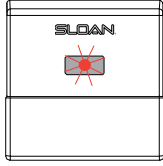

EXPOSED URINAL FLUSHOMETERS

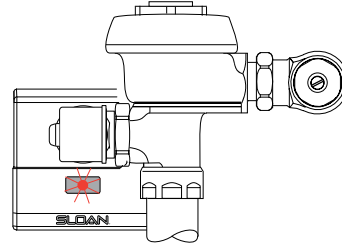

11 - TURN WATER ON AND ADJUST CONTROL STOP

- A** Adjust control stop to meet the flow rate required for proper cleansing of the fixture. Open control stop COUNTERCLOCKWISE one (1) FULL turn from the closed position.
- B** Activate flushometer by placing hand in front of sensor lens for ten (10) seconds and then moving it away.
- C** Adjust control stop after each flush until the rate of flow delivered properly cleanses the fixture.

EXPOSED URINAL FLUSHOMETER

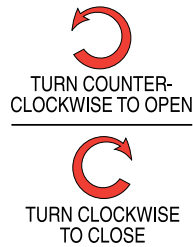
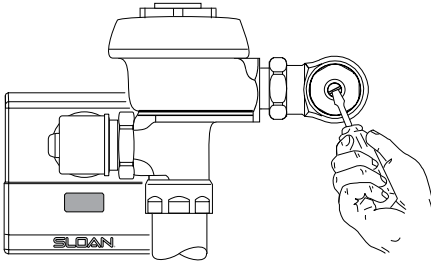

!!! IMPORTANT !!!

SLOAN'S FLUSHOMETERS ARE ENGINEERED FOR QUIET OPERATION. EXCESSIVE WATER FLOW CREATES NOISE, WHILE TOO LITTLE WATER FLOW MAY NOT SATISFY THE NEEDS OF THE FIXTURE. PROPER ADJUST IS MADE WHEN PLUMBING FIXTURE IS CLEANSED AFTER EACH FLUSH WITHOUT SPLASHING WATER OUT FROM THE LIP AND A QUIET FLUSHING CYCLE IS ACHIEVED.

NEVER OPEN CONTROL STOP TO WHERE THE FLOW FROM THE VALVE EXCEEDS THE FLOW CAPABILITY OF THE FIXTURE. IN THE EVENT OF A VALVE FAILURE, THE FIXTURE MUST BE ABLE TO ACCOMMODATE A CONTINUOUS FLOW FROM THE VALVE.

12 - VANDAL RESISTANT CONTROL STOP CAP INSTALLATION AND REMOVAL (EXPOSED MODELS ONLY)

- A** Thread the plastic sleeve onto the stop bonnet until it is snug (hand tight only; do not use pliers or a wrench).
- B** Place the metal control stop cap over the plastic sleeve and using the palm of the hand, push or "pop" the cap over the fingers of the sleeve. The cap should spin freely on the insert.

!!! IMPORTANT !!!

DO NOT INSTALL THE CAP ONTO THE SLEEVE UNLESS THE SLEEVE HAS BEEN THREADED ONTO THE CONTROL STOP BONNET. IF ASSEMBLED WHEN OFF OF THE CONTROL STOP, THE SLEEVE WILL NOT COME APART FROM THE CAP.

- C** To remove vandal resistant stop cap — Using a large flat screwdriver, gently lift the cap from the control stop as follows. Insert the screwdriver blade between the bottom edge of the cap and the flat surface of the control stop body. Using the screwdriver as a lever, push the screwdriver handle straight back toward the wall. Gently lift the cap from the sleeve. It may be necessary to work the screwdriver around the diameter of the cap to further lift the cap from the sleeve.
- D** Once the cap has been lifted away from the control stop, grasp the cap and pull it off the sleeve.

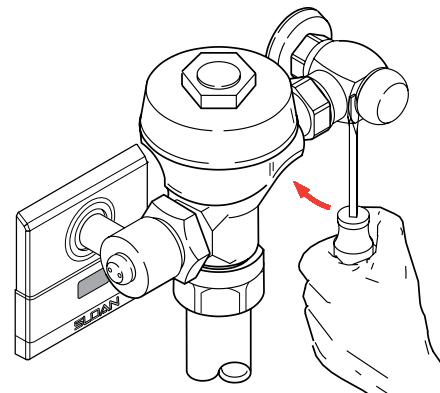
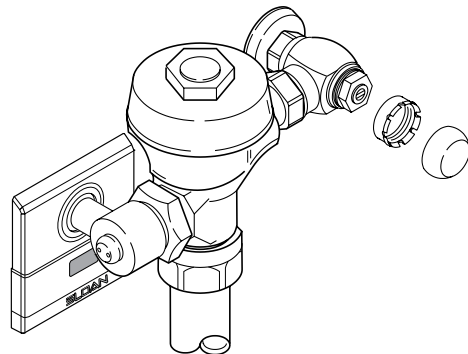

OPERATION

1. A continuous, invisible light beam is emitted from the sensor.
2. When a user enters the beam's effective range, water closets – 22" to 42" (559 mm to 1067 mm) and urinals – 15" to 30" (381 mm to 762 mm), the beam is reflected into the sensor's scanning window and transformed into a low voltage electrical signal that activates a ten-second time delay circuit. The time delay circuit eliminates false operation from passers-by in the restroom. Once the time delay is completed, the output circuit is alerted and continues in a "hold" mode for as long as the user remains within the effective range of the sensor.
3. When the user steps away from the sensor, the loss of reflected light immediately initiates an electrical "one-time" signal that energizes the solenoid operator, and activates the flushometer to flush the fixture. The circuit then automatically resets and is ready for the next user.

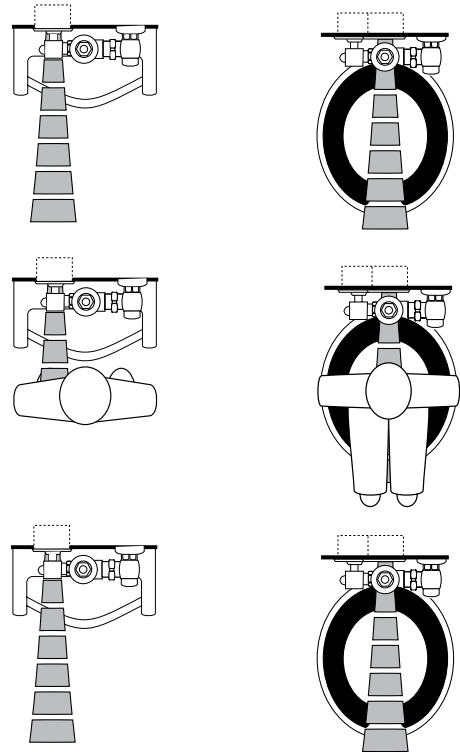

CARE AND CLEANING

DO NOT use abrasive or chemical cleaners (including chlorine bleach) to clean flushometers and sensor window as they may dull the luster and attack the chrome or special decorative finishes. Use ONLY soap and water, then wipe dry with clean cloth or towel.

While cleaning the bathroom tile, the flushometer should be protected from any splattering of cleaner. Acids and cleaning fluids can discolor or remove chrome plating.

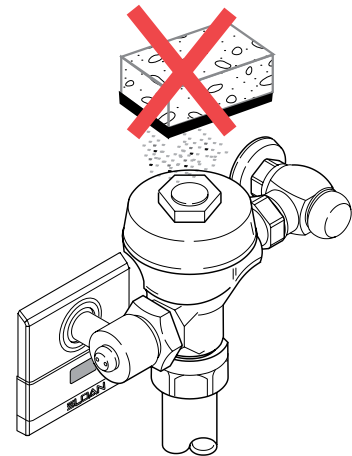

TROUBLESHOOTING GUIDE

NOTE: URINALS – When the sensor detects a user, a slow flashing red light appears in the sensor window. After eight (8) to ten (10) seconds, the light flashes rapidly to indicate that the sensor is armed. When the sensor no longer detects a user, the sensor immediately activates the solenoid valve after a 0.5 second delay.

WATER CLOSETS – Detection and activation are the same as for the urinal except when the sensor no longer detects an user, the sensor activates the solenoid valve after a three (3) second delay.

1. Valve does not function (red light does not flash when user steps in front of sensor).

- A. No power is being supplied to sensor. Ensure that the main power is turned “ON.” Check transformer, leads and connections. Repair or replace as necessary.
- B. EL-1500 sensor is not operating. Replace EL-1500 sensor.

2. Valve does not function (red light flashes when user steps in front of sensor).

INDICATOR: Red light stops flashing when user steps away and valve makes a “clicking” sound but does not flush.

- A. No water is being supplied to the valve. Make certain that water supply is turned “ON” and the control stop is open.
- B. EL-128-A cartridge is fouled or jammed. Turn electronic power to valve “OFF” (failure to do so could result in damage to the sensor module). Remove the solenoid operator from the valve and remove the EL-128-A cartridge. Clean and/or repair as necessary.

INDICATOR: The red light stops flashing when user steps away but the valve does NOT make a “clicking” sound and does NOT flush.

- A. EL-163-A solenoid shaft assembly is fouled or jammed. Turn electronic power to valve “OFF” (failure to do so could result in damage to the sensor module). Remove EL-101 or EL-166 nut from the solenoid operator. Remove the coil from the solenoid operator. Use a spanner wrench or pliers to remove the EL-163-A solenoid shaft assembly from valve. Clean and/or replace as necessary. Be sure to replace plunger spring when reassembling solenoid shaft assembly.

INDICATOR: The red light flashes three (3) short flashes, three (3) long flashes then three (3) short flashes (“S-O-S”) and continues to repeat this cycle even when user steps out of the sensor’s detection range.

- A. EL-1500 sensor wiring connections are incorrect. Rewire sensor to valve. One solenoid lead connects to the “TO VALVE” connection on sensor. One transformer lead connects to the “24 VAC IN” connection on sensor. Second solenoid lead and second transformer lead connect together.
- B. Wiring to sensor is ground shorted. Find short in wiring circuit and correct.
- C. EL-165-2 solenoid coil is burnt out or coil is not connected to solenoid plunger shaft. Reinstall or replace coil as necessary.

3. Volume of water is insufficient to adequately siphon fixture.

- A. Control stop is not open wide enough. Adjust control stop for desired water delivery.
- B. Low consumption unit is installed on water saver or conventional fixture. Replace diaphragm component parts of valve with kit that corresponds to appropriate flush volume of fixture.
- C. Inadequate water volume or pressure available from supply. Increase pressure or supply (flow rate) to the valve. Consult factory for assistance.

4. Length of flush is too long (long flushing) or valve fails to shut off.

- A. Water saver valve is installed on low consumption fixture. Replace diaphragm component parts of valve with kit that corresponds to appropriate flush volume of fixture.
- B. Relief valve in diaphragm is not seated properly or bypass hole in diaphragm is clogged. Disassemble inside diaphragm component parts and wash parts thoroughly. Replace worn parts if necessary.

5. Water splashes from fixture.

- A. Supply flow rate is more than necessary. Adjust control stop to meet flow rate required for proper cleansing of the fixture.
- B. Closet valve is installed on urinal fixture. Replace closet diaphragm component parts with proper urinal kit (inside diaphragm assembly or inside parts kit).

**If further assistance is required, please contact Sloan Technical Support at:
1-888-SLOAN-14 (1-888-756-2614)
or visit us online at:
www.sloanvalve.com**

!!! IMPORTANT !!!

PROTECT THE FINISH OF THE FLUSHOMETER – DO NOT USE TOOTHED TOOLS TO INSTALL OR SERVICE THESE VALVES. USE A SLOAN A-50 Super-Wrench™, Sloan A-109 Plier Wrench OR SMOOTH JAWED SPUD WRENCH TO SECURE ALL COUPLINGS. ALSO SEE “CARE AND CLEANING” SECTION.

!!! IMPORTANT !!!

NEVER OPEN CONTROL STOP TO WHERE THE FLOW FROM THE VALVE EXCEEDS THE FLOW CAPABILITY OF THE FIXTURE. IN THE EVENT OF A VALVE FAILURE, THE FIXTURE MUST BE ABLE TO ACCOMMODATE A CONTINUOUS FLOW FROM THE VALVE.

!!! IMPORTANT !!!

THIS PRODUCT CONTAINS MECHANICAL AND/OR ELECTRICAL COMPONENTS THAT ARE SUBJECT TO NORMAL WEAR. THESE COMPONENTS SHOULD BE CHECKED ON A REGULAR BASIS AND REPLACED AS NEEDED TO MAINTAIN THE VALVE’S PERFORMANCE.

!!! IMPORTANT !!!

DO NOT INSTALL THE CAP ONTO THE SLEEVE UNLESS THE SLEEVE HAS BEEN THREADED ONTO THE CONTROL STOP BONNET. IF ASSEMBLED WHEN OFF OF THE CONTROL STOP, THE SLEEVE WILL NOT COME APART FROM THE CAP.

!!! IMPORTANT !!!

LAWS AND REGULATIONS PROHIBIT THE USE OF HIGHER FLUSHING VOLUMES THAN LISTED ON FIXTURE OR FLUSHOMETER.

URINAL PARTS LIST

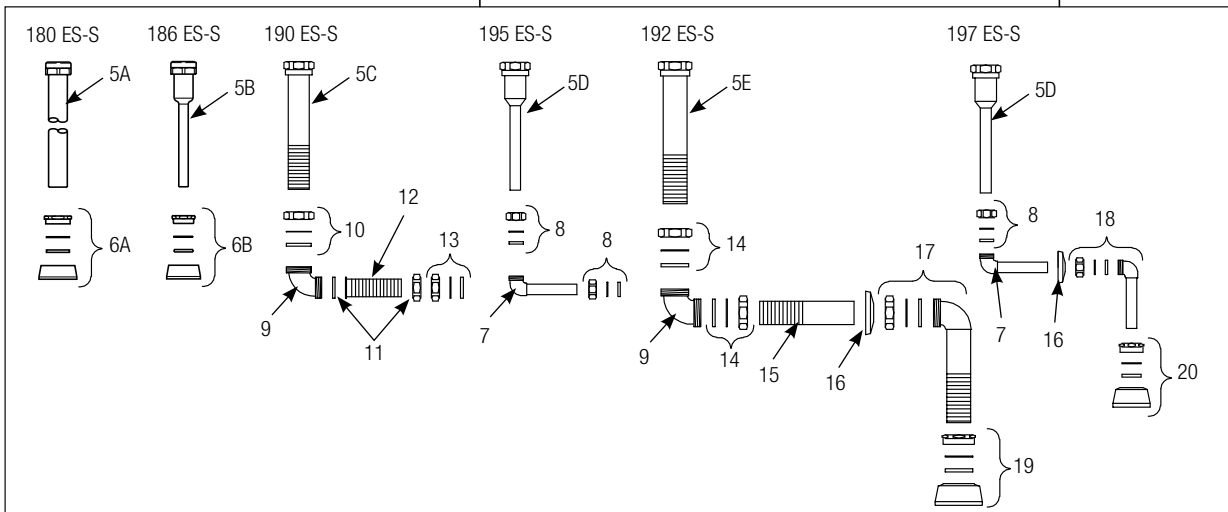
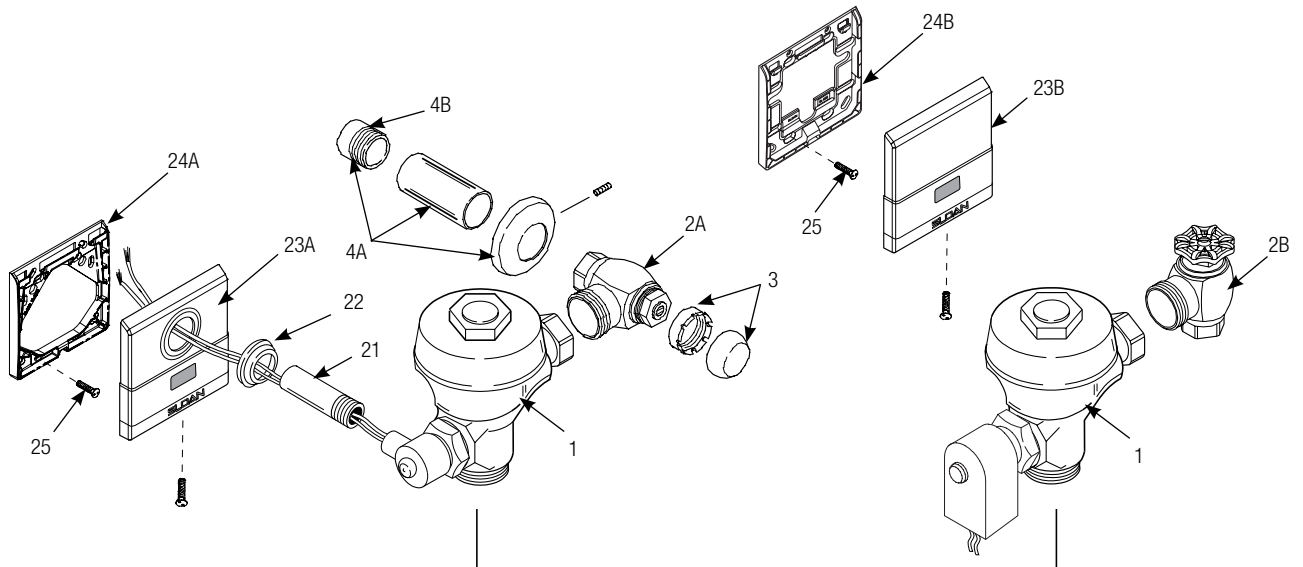

| Item No. | Part No. | Description |
|----------|-----------|--|
| 1 | ‡ | Solenoid Operated Valve Assembly |
| 2A | H-700-A ‡ | 1" (25 mm) Exposed Bak-Chek® Control Stop |
| | H-700-A ‡ | ¾" (20 mm) Exposed Bak-Chek® Control Stop |
| 2B | H-730-A ‡ | 1" (25 mm) Conc. Wheel Handle Bak-Chek® Control Stop |
| | H-730-A ‡ | ¾" (20 mm) Conc. Wheel Handle Bak-Chek® Control Stop |
| 3 | H-1010-A | Vandal Resistant Stop Cap |
| 4A | H-633-AA | 1" (25 mm) Sweat Solder Kit (Exposed Models) |
| | H-636-AA | ¾" (19 mm) Sweat Solder Kit (Exposed Models) |
| 4B | H-532 | Adapter, 1" NPT to 1" Tube |
| | H-535 | Adapter, ¾" NPT to ¾" Tube |
| 5A | V-600-AA | 1¼" (32 mm) x 9" (229 mm) Vacuum Breaker Assembly CP (Model 180 ES-S) |
| 5B | V-600-AA | ¾" (20 mm) x 9" (229 mm) Vacuum Breaker Assembly CP (Model 186 ES-S) |
| 5C | V-500-AA | 1½" (38 mm) x 11½" (292 mm) Vacuum Breaker Assembly RB (Model 190 ES-S) |
| 5D | V-500-AA | ¾" (20 mm) x 10½" (267 mm) Vacuum Breaker Assembly RB (Models 195 ES-S and 197 ES-S) |
| 5E | V-500-AA | 1½" (38 mm) x 7½" (191 mm) Vacuum Breaker Assembly RB (Model 192 ES-S) |
| 6A | F-5-A | 1¼" (32 mm) Spud Coupling Assembly (Model 180 ES-S) |
| 6B | F-5-A | ¾" (20 mm) Spud Coupling Assembly (Model 186 ES-S) |
| 7 | F-15-A | ELL with ¾" (20 mm) Tail (Models 195 ES-S and 197 ES-S) |
| 8 | F-2-AW | ¾" (20 mm) Slip Joint Coupling (Models 195/197 ES-S) |

| Item No. | Part No. | Description |
|----------|----------|---|
| 9 | F-21 | Double Slip Elbow (Models 190 ES-S and 192 ES-S) |
| 10 | F-2A | 1½" (38 mm) Slip Joint Coupling (Model 190 ES-S) |
| 11 | F-2A | Coupling with S-21 Gasket |
| 12 | F-110 | 1¼" (32 mm) O.D. Outlet |
| 13 | F-2-A-U | 1¼" (32 mm) Slip Joint Coupling |
| 14 | F-2-AA | 1½" (38 mm) Slip Joint Coupling (Set of Two) (Model 192 ES-S) |
| 15 | F-102 | 1½" Outlet Tube CP |
| 16 | F-7 | Flange |
| 17 | F-25-A | 1¼" Elbow Assembly |
| 18 | F-15-A | ELL with ¾" Tail CP (Model 197 ES-S) |
| 19 | F-5-A | 1¼" Spud Coupling Assembly CP |
| 20 | F-5-A | ¾" Spud Coupling Assembly CP |
| 21 | F-15 | Tail Assembly |
| 22 | EL-431-A | Flange Assembly |
| 23A | EL-640-A | Cover Plate with Sensor & Mounting Hardware Assembled (Exposed Models) (includes EL-549 mounting plate) |
| 23B | EL-645-A | CP Cover Plate with Sensor Assembled (Concealed Models) |
| 24A | EL-549 | Mounting Plate (Exposed Models) |
| 24B | EL-592 | Mounting Plate (Concealed Models) |
| 25 | EL-177 | Screws (requires four (4) screws per mounting plate) |
| | EL-1500 | Urinal Sensor Replacement |

‡ Part number varies with valve model variation; consult factory.

INSTALLATION TEMPLATE: For Models 180/186 ES-S:
Code # 0816156

WATER CLOSET PARTS LIST

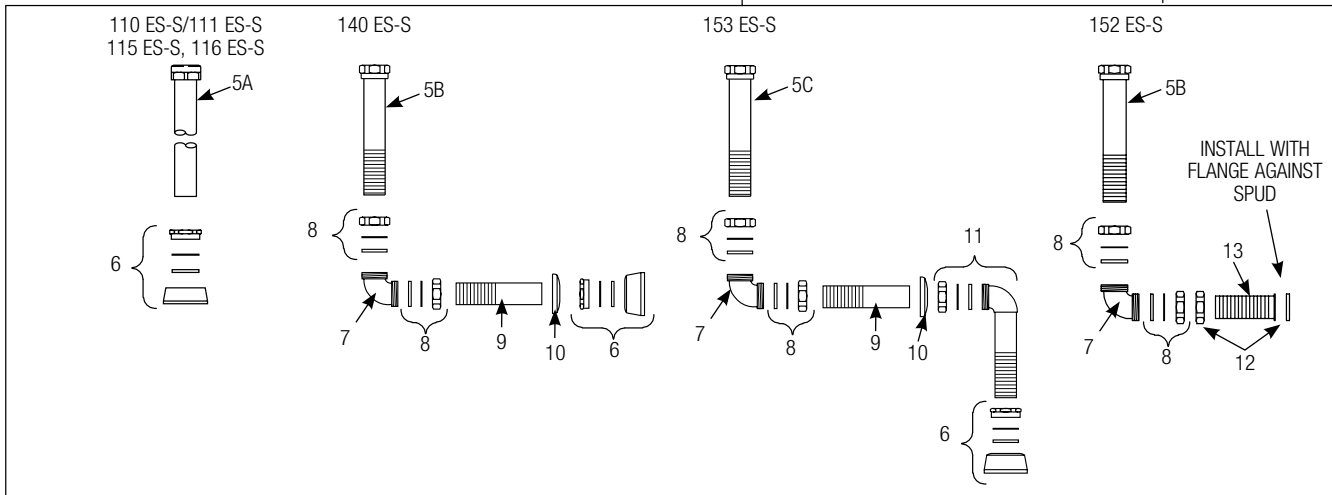
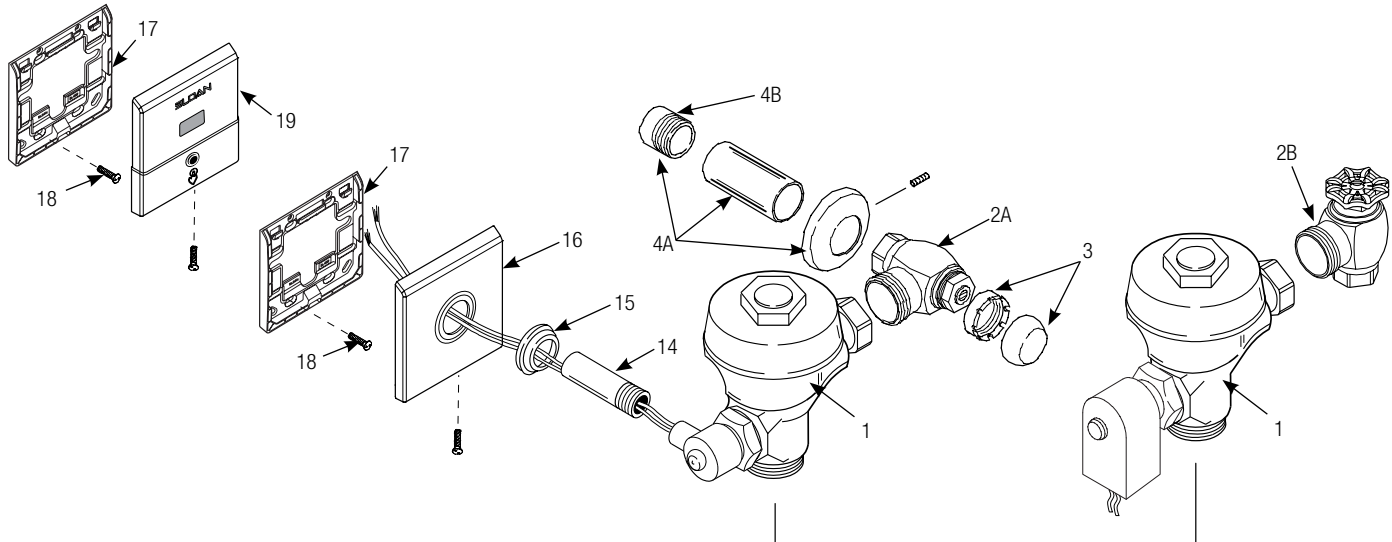

| Item No. | Part No. | Description |
|----------|-----------|---|
| 1 | ‡ | Solenoid Operated Valve Assembly |
| 2A | H-700-A ‡ | 1" (25 mm) Exposed Bak-Chek® Control Stop |
| 2B | H-730-A ‡ | 1" (25 mm) Conc. Wheel Handle Bak-Chek® Control Stop |
| 3 | H-1010-A | Vandal Resistant Stop Cap |
| 4A | H-633-AA | 1" (25 mm) Sweat Solder Kit (Exposed Models) |
| 4B | H-532 | Adapter, 1" NPT to 1" Tube |
| 5A | V-600-A | 1½" (38 mm) x 9" (229 mm) Vacuum Breaker Assembly (Model 110/111 ES-S) |
| | | 1½" (38 mm) x 21½" (546 mm) Vacuum Breaker Assembly (Model 115 ES-S) |
| | | 1½" (38 mm) x 24½" (622 mm) Vacuum Breaker Assembly (Model 116 ES-S) |
| 5B | V-500-A | 1½" (38 mm) x 11½" (292 mm) Vacuum Breaker Assembly RB (Models 140 ES-S & 152 ES-S) |
| 5C | V-500-A | 1½" (38 mm) x 6" (152 mm) Vacuum Breaker Assembly RB (Model 153 ES-S) |
| 6 | F-5-A | 1½" (38 mm) Spud Coupling Assembly CP |
| 7 | F-21 | 1½" (38 mm) Double Slip Elbow |

| Item No. | Part No. | Description |
|----------|-----------|--|
| 8 | F-2-AA | 1½" (38 mm) Slip Joint Coupling (Set of Two) |
| 9 | F-102 | 1½" (38 mm) Outlet Tube CP |
| 10 | F-7 | Flange |
| 11 | F-25-A | 1½" (38 mm) Elbow Assembly |
| 12 | F-2-A | Coupling with S-21 Gasket |
| 13 | F-102 | 1½" (38 mm) Outlet Tube CP |
| 14 | F-15 | Tail Assembly |
| 15 | EL-431-A | Flange Assembly |
| 16 | EL-625-A | CP Cover Plate with Mounting Hardware Assembled (Closet only) (includes EL-543 mounting plate) |
| 17 | EL-592 | Mounting Plate (Closet only) |
| 18 | EL-177 | Screws (requires four screws per mounting bracket) |
| 19 | EL-595-A | CP Cover Plate with Sensor and Override Switch Assembled (Closet only) |
| | EL-1500-L | Closet Sensor Replacement Kit (Closet only) |

‡ Part number varies with valve model variation; consult factory.
INSTALLATION TEMPLATE: For Models 110/111 ES-S:
 Code # 0816157

Manufactured by Sloan Valve Company under one or more of the following patents: 5,558,120; 5,564,460; D399,932; 5,649,686; 5,865,420; 5,887,848; 5,967,182; D626,630; 6,616,119

The information contained in this document is subject to change without notice.

SLOAN HEADQUARTERS • 10500 SEYMOUR AVENUE • FRANKLIN PARK, IL 60131

Phone: 1-800-982-5839 or 1-847-671-4300 • Fax: 1-800-447-8329 or 1-847-671-4380 • www.sloanvalve.com

© 2012 SLOAN VALVE COMPANY

Code No. 0816164 – Rev. 5 (01/12)