



INSTALLATION & OPERATION INSTRUCTIONS **HYDROMAX™** INDIRECT-FIRED WATER HEATERS

1400 Division Road, West Warwick, RI 02893 ▲ T: 401.884.6300 ▲ F: 401.885.2567 ▲ www.amtrol.com

**PLEASE READ THE FOLLOWING INSTRUCTIONS CAREFULLY
INSTALLER: LEAVE THIS MANUAL WITH THE OWNER**



**Models Covered:
HM-41 & HM-80**

IMPORTANT GENERAL SAFETY INFORMATION - ADDITIONAL SPECIFIC SAFETY ALERTS APPEAR IN THE FOLLOWING INSTRUCTIONS.

⚠ WARNING DO NOT LIFT OR CARRY WATER HEATER BY THE TOP COVER. WATER HEATER DAMAGE OR PERSONAL INJURY MAY OCCUR IF THE COVER BECOMES DETACHED.

⚠ WARNING READ CAREFULLY THE PRODUCT INSTALLATION, OPERATING AND MAINTENANCE MANUAL. FAILURE TO FOLLOW THE INSTRUCTIONS AND WARNINGS IN THE MANUAL MAY RESULT IN SERIOUS OR FATAL INJURY AND/OR PROPERTY DAMAGE, AND WILL VOID THE PRODUCT WARRANTY. THIS PRODUCT MUST BE INSTALLED BY A QUALIFIED PROFESSIONAL. FOLLOW ALL APPLICABLE LOCAL AND STATE CODES AND REGULATIONS. IN THE ABSENCE OF SUCH CODES, FOLLOW THE CURRENT EDITIONS OF THE NATIONAL PLUMBING CODE AND NATIONAL ELECTRIC CODE, AS APPLICABLE.



THIS IS THE SAFETY ALERT SYMBOL. IT IS USED TO ALERT YOU TO POTENTIAL PERSONAL INJURY AND OTHER HAZARDS. OBEY ALL SAFETY MESSAGES THAT FOLLOW THIS SYMBOL TO REDUCE THE RISK OF PERSONAL INJURY AS WELL AS PROPERTY DAMAGE.

⚠ CAUTION The heat transfer medium must be water or other nontoxic fluid having a toxicity rating or class of 1, as listed in Clinical Toxicology of Commercial Products, 5th edition. The pressure of the heat transfer medium must be limited to 30 PSIG by an approved safety or relief valve.

1. Table Of Contents

2. Pre-Installation Checklist.....	2	7. Mechanical Aquastat Wiring.....	8
3. Required Components and Accessories Checklist.....	3	8. Startup Procedure.....	9
4. HYDROMAX™ Plumbing.....	4	9. Troubleshooting.....	9
5. Ener-G-NET™ Wiring.....	5-6	10. General Safety Information.....	10
6. Ener-G-NET™ Setup & Adjustment.....	7	11. Replacement Parts.....	11

2. Pre-Installation Checklist

IMPORTANT STEPS AND DECISIONS REQUIRED BEFORE INSTALLATION

- THIS PRODUCT MUST BE INSTALLED AND MAINTAINED BY A LICENSED PROFESSIONAL PLUMBER, ELECTRICIAN, AS APPLICABLE. IN ADDITION TO THE INSTRUCTIONS IN THIS MANUAL, FOLLOW ALL APPLICABLE LOCAL AND STATE CODES INCLUDING MA CMR 248 OR IN THE ABSENCE OF SUCH CODES, THE CURRENT EDITIONS OF THE NATIONAL PLUMBING CODE AND THE NATIONAL ELECTRIC CODE.**
- DRIP PAN AND DRAIN:** This appliance should not be installed in an area where leakage of the tank or connections can result in damage to the area adjacent to the appliance or to lower floors of the structure. When such locations cannot be avoided, a suitable drain pan, adequately drained and kept clear, must be installed under the appliance.
- CAUTION:** Determine whether your water is corrosive or acidic, and that there are no suspended solids, toxic or other substances or abnormally high chlorine levels in the water that could damage or affect the water heater or the rest of your plumbing system.

NOTICE: In this non-priority option, the water heater will be supplied just as another zone. This means that if all space heating zones call for hot boiler water at the same time, the water heater may not be supplied with enough hot boiler water to “recover” adequately. The delivery of domestic hot water will be diminished. In many, but not all cases, this is not a problem because the routine oversizing of boiler output is adequate for both loads.

2. Priority System - Under this wiring option the water heater will be supplied before space heating.

⚠ WARNING In limited circumstances, space heating can be lost in the home in this priority mode. Any demand for space heating is postponed until the water heater has reached its set temperature. This delay in supplying the space heating zones is usually not noticed by the inhabitants of the living spaces. However, in the event of certain malfunctions such as circulator or thermostat failure, space heating could be delayed indefinitely. If undetected and uncorrected, freezing damage to piping could result.

⚠ WARNING USE GLYCOL ONLY WITH DOUBLE-WALLED HEAT EXCHANGER MODELS. Glycol is a poisonous substance. To avoid seepage or leakage of glycol to surfaces where humans or animals can ingest it, use glycol only in double-walled units, so that any leaks will most likely be released to the atmosphere. However, a leak to a surface area may still occur, so any use of glycol must be monitored closely and humans and animals should be protected from contact with the unit.

⚠ WARNING Do not connect the water heater domestic supply with baseboard or other space heating units or elements. Any contaminants in the baseboard units will contaminate the potable water in the water heater and also adversely affect its performance.

- Wiring Options. Select either a Non-Priority or Priority System:**
Two options are available when wiring the controls of the water heater in the space heating system (boiler and distribution elements).
 - 1. Non-Priority System** - The controls of the water heater must be wired as a separate heating zone with a standard zone valve or a separate circulator dedicated to the water heater “zone”.

- Select Circulator versus Zone Valve**
The flow of hot boiler water to the water heater can be controlled with either a motorized zone valve or a circulator.
 - 1. Separate circulator.** The recommended way to provide adequate flow through the water heater heat exchanger is to use a separate dedicated circulator. This option may be used even though the heating system utilizes zone valves.
 - 2. Zone valve** If a zone valve is to be used, a flow rate of 3 to 5 gpm with all zones in use is required. A full-port zone valve should be used.
- All installations require a low-water cut-off or automatic fill valve on your boiler system to reduce the risk of boiler water loss.
- Steam boiler installations require a low-water cut-off which is also required by most codes.
- Installation of a vacuum breaker is required to prevent damage to the water heater when drained. There must be no valves installed between the vacuum breaker and water heater.

3. Required Components And Accessories Checklist

MODEL	CIRCULATOR PERFORMANCE	ZONE VALVE	SHUTOFF VALVES	RELIEF VALVE	THERMAL EXPANSION TANK
HM-41	4 GPM @ 6 FT	3/4" Full Port	4	Included	2.0 Gallon
HM-80	4 GPM @ 6 FT	3/4" Full Port	4	Included	4.4 Gallon

CAUTION If a steel hydropneumatic tank is in place, replace it with a properly sized diaphragm expansion tank. Otherwise, significant heat transfer problems can occur by causing air to be trapped in the heat exchanger. If the boiler system has an existing expansion tank and the boiler temperatures are being changed, resize the existing diaphragm expansion tank.

CAUTION Use care when using a torch near the top cover and heat exchanger plate. It is recommended that the front half be removed prior to soldering to avoid potential damage.

HYDROMAX™ Components (Single Wall Shown)

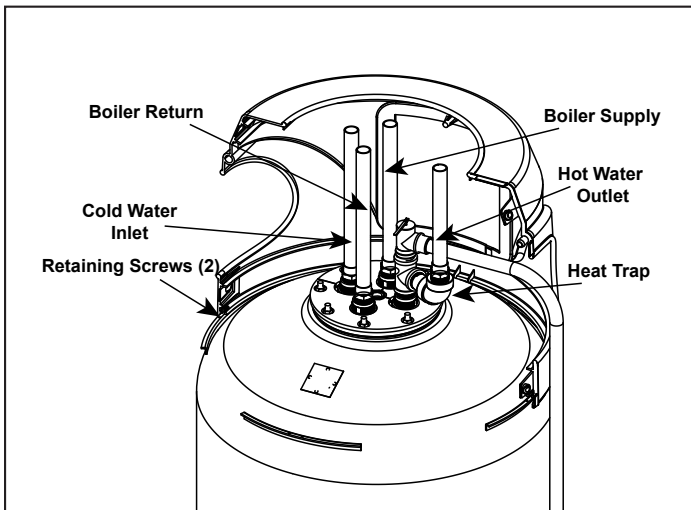

Heat Exchanger Pressure Loss

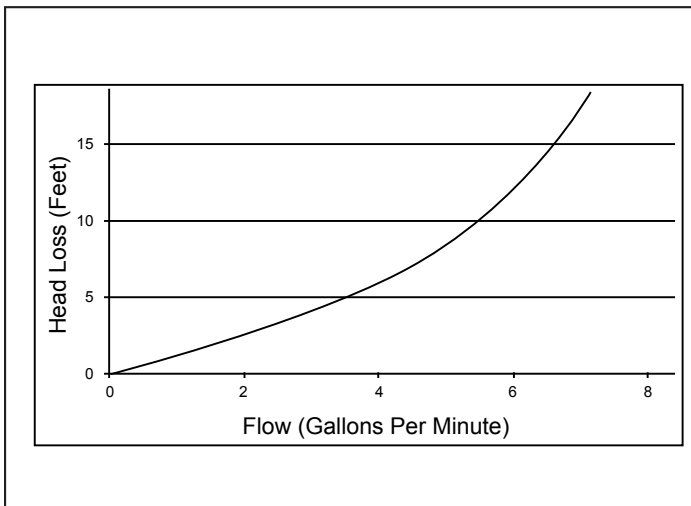

Two-Piece Cover Removal and Installation

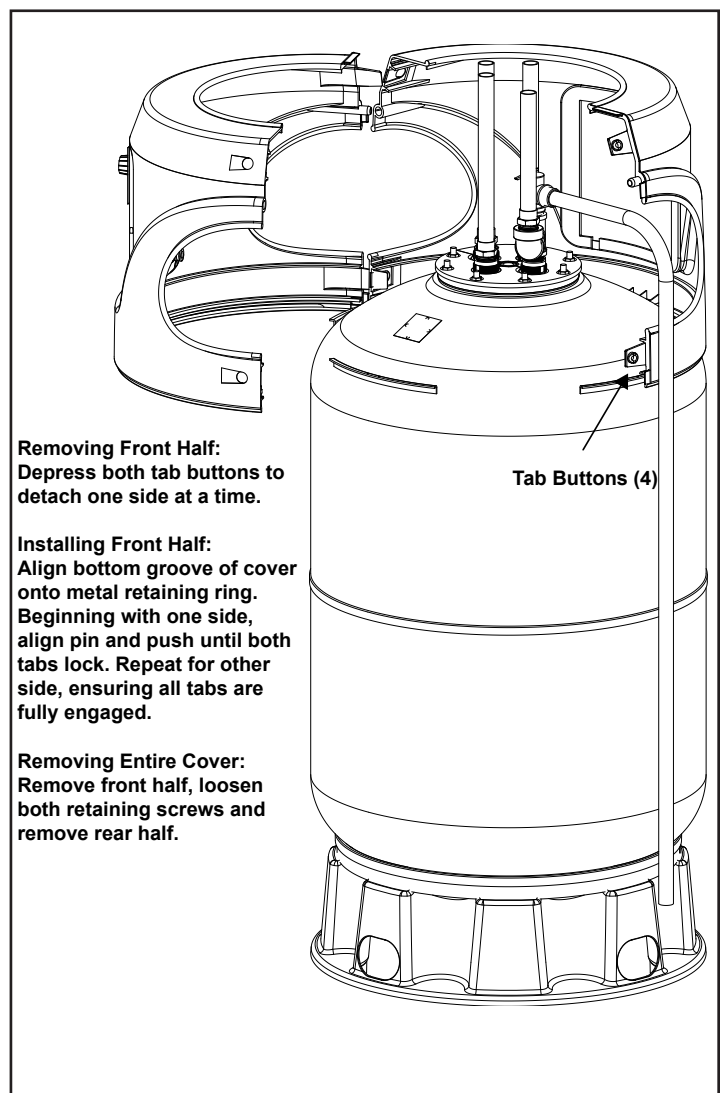

4. HYDROMAX™ Plumbing

DOMESTIC WATER PIPING

1. Connect the cold water supply to the pipe labeled COLD WATER.
2. Connect the HOT WATER piping to the domestic hot water system.
3. When all domestic water piping is complete, open the cold water supply and allow some water to enter the tank. Look and listen for signs of leaks and repair as necessary before continuing.

Note: If installing on a city supply, a properly sized thermal expansion tank is required and should be installed in accordance with the product installation manual.

Note: If a water heater is installed in a closed water supply system, such as one having a back-flow preventer in the cold water supply, means shall be provided to control thermal expansion. Contact the water supplier or local plumbing inspector on how to control this situation.

Note: If an external electrical source is utilized, the appliance, when installed, must be electrically grounded in accordance with local codes or, in the absence of local codes, with the National Electrical Code, ANSI/NFPA 70.

Note: The thermostat is adjusted to 120° F, when shipped from the factory.

4. Install the blowdown tube on the T&P relief valve outlet. Plumb to within 6 inches above a floor drain or as directed by plumbing code.

Clearance From Combustible Surfaces

LEFT SIDE.....	1"	REAR.....	1"
RIGHT SIDE.....	1"	FLOOR.....	0"
TOP.....	9"	FRONT.....	1"

CAUTION Do not drill, puncture or otherwise penetrate the steel outer tank shell. Do not screw pipe hangers or other hardware into the exterior of the tank.

BOILER PIPING

1. Plumb the circulator or zone valve on the BOILER SUPPLY line.
2. Pipe the BOILER RETURN connection to the boiler return line.

CAUTION Be sure the return line is NOT plumbed to the suction side of any heating circulators. This may require moving the heating circulator off the boiler tapping on packaged boilers. Failure to do so will result in overheating and tank damage when the heating system is in operation.

3. Install a weighted flow check on the boiler return line. This is not necessary on systems utilizing a zone valve to control the water heater temperature.
4. After completing the boiler piping, slowly open the boiler fill valve and pressurize the water heater loop. Check for leaks and repair as necessary. Proceed to the appropriate wiring section in this manual.

! DANGER EXPLOSION HAZARD. Do not install to a high pressure steam boiler (greater than 15 psig). An explosion could occur.

Recommended Clearance for Servicing

LEFT.....	12"	HEAD ROOM.....	36"
RIGHT.....	12"	REAR.....	1"
FRONT.....	30"		

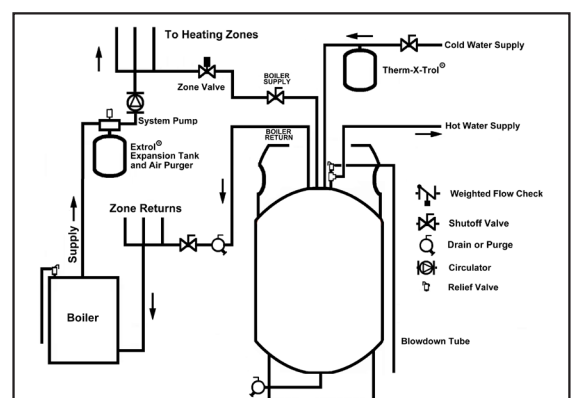
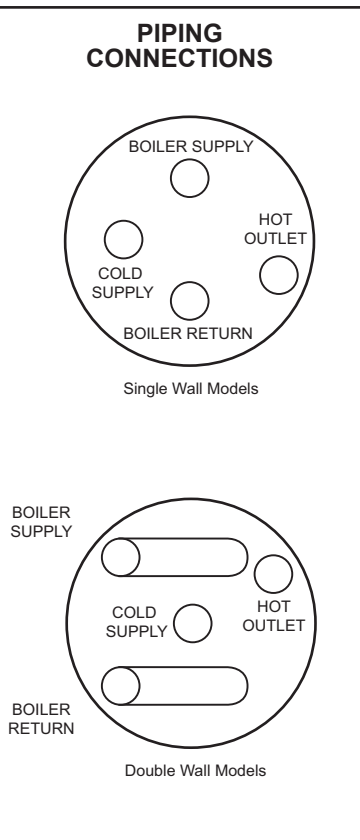
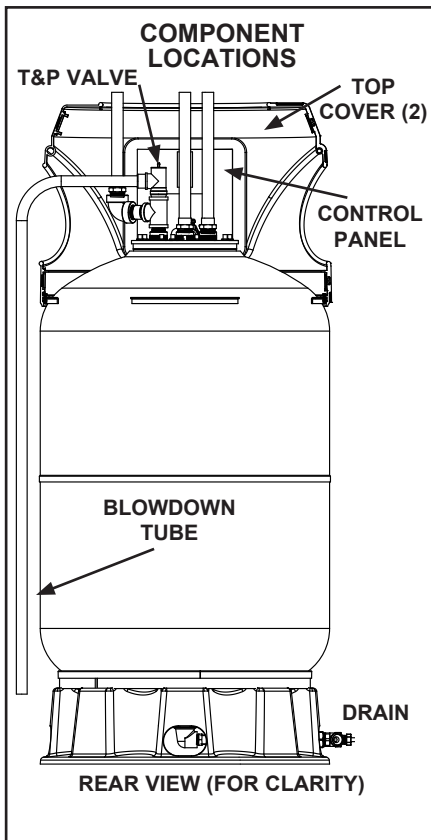

PIPING USING ZONE VALVE

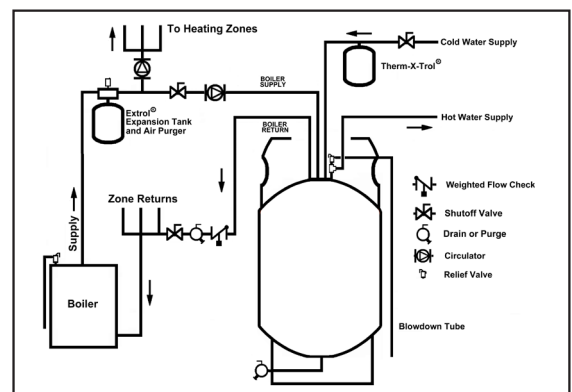

5. Ener-G-NET™ Wiring



Ener-G-NET incorporates all of the temperature sensing and control necessary for HYDROMAX™ operation. Built-in switching relays may be wired to operate the boiler control and circulator pump or zone valve. The diagram below illustrates these internal switching functions.

Examples of common wiring scenarios are provided on the following page.

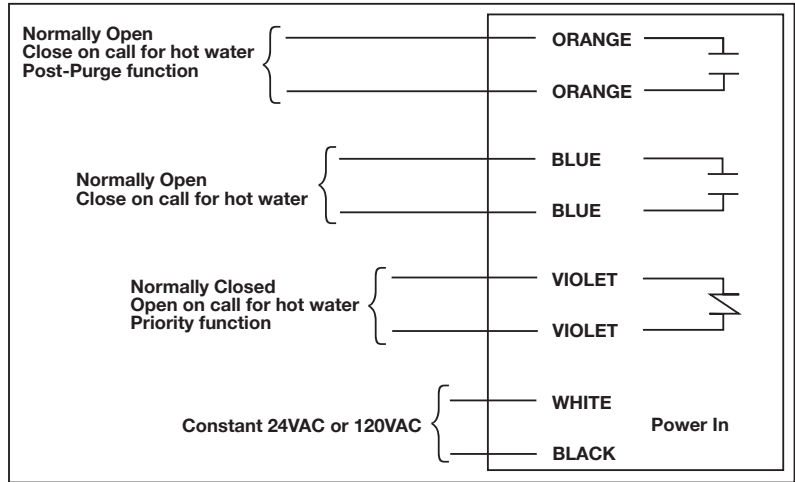
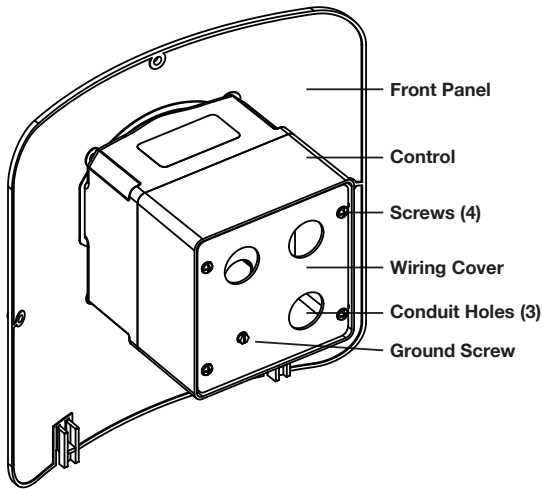

After wiring is complete, insert the white temperature sensor (thermistor) plug into the receptacle at the base of the digital control. Select the plug marked CIRCULATOR or ZONE VALVE based on the application. Zone valves can be slow actuating. Therefore, the zone valve sensor contains a built-in temperature offset to account for the time it takes the zone valve to fully close. This results in potable water temperature that is representative of the digital control temperature set point. This is why it is important to install the correct sensor into the digital control. See Page 2 for information regarding the selection of a circulator or zone valve.

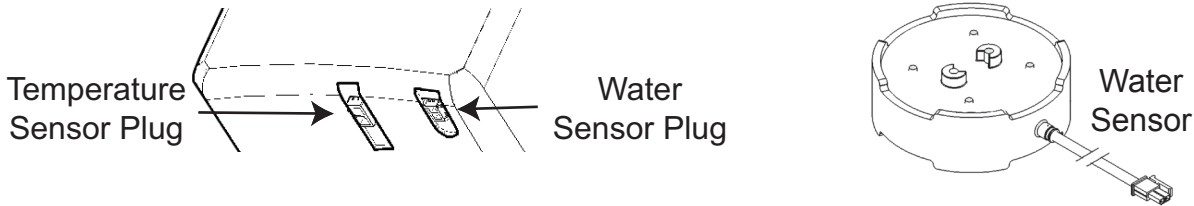

NOTE: This sensor should not be the primary means of water detection. US PATENT NO: 7,671,754 and other patents pending.

NOTE: Line-voltage and safety-circuit wiring which is external to the water heater jacket when all panels are in place, and which is part of the appliance, shall be protected by metal conduit, metal-clad cable or raceways. "Power Limited Circuit Cable" needed not be provided with the protection specified above if it is securely fastened to the appliance jacket and follows the contour of the appliance jacket. Thermoelectric wiring shall be exempt from this provision.

NOTE: Strain relief shall be provided for all conductors leaving an enclosure. For low-voltage wiring, strain relief at the point of exit from an enclosure is not necessary if, by wire location or support, protection is provided against accidental strain.

NOTE: For models equipped with a water sensor, the water sensor should be placed flat on the floor in a low-traffic area. On a regular basis, verify that the water sensor is functioning properly by placing the orange puck in a water puddle or insert a coin between the two electrodes and listen for audible alarm.

Ener-G-NET™ Wiring

Common wiring diagrams are shown below. Select the appropriate diagram for the application. Diagrams are popular examples only. If your application is not shown, contact Amtrol Technical Support at 401.535.1216. **NOTE:** Ensure the Ener-G-NET installation is within the following application and operating parameters:

- Ambient temperature from 38° to 125°F
- Relative humidity ranging from 20% to 90% (non-condensing).
- Boiler load rating up to 15A resistive, 1/4hp inductive @ 120VAC.
- Circulator load rating up to 15A, 1/4hp inductive @ 120VAC.
- Space heating load rating up to 8A @ 120VAC.

Oil Burner Controls

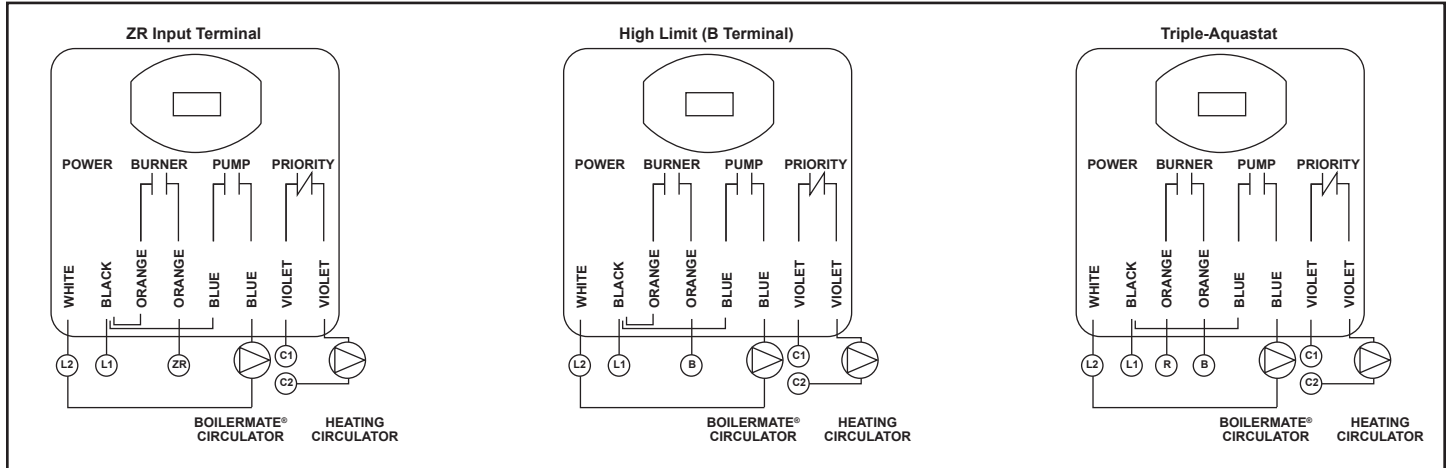

Gas Valve Controls

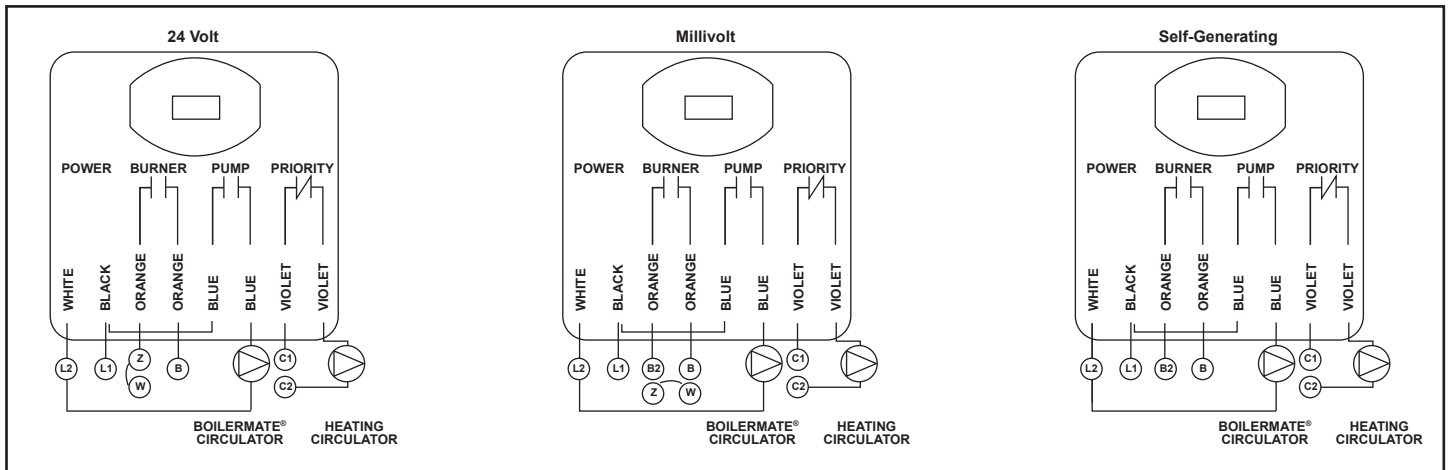

Other Applications

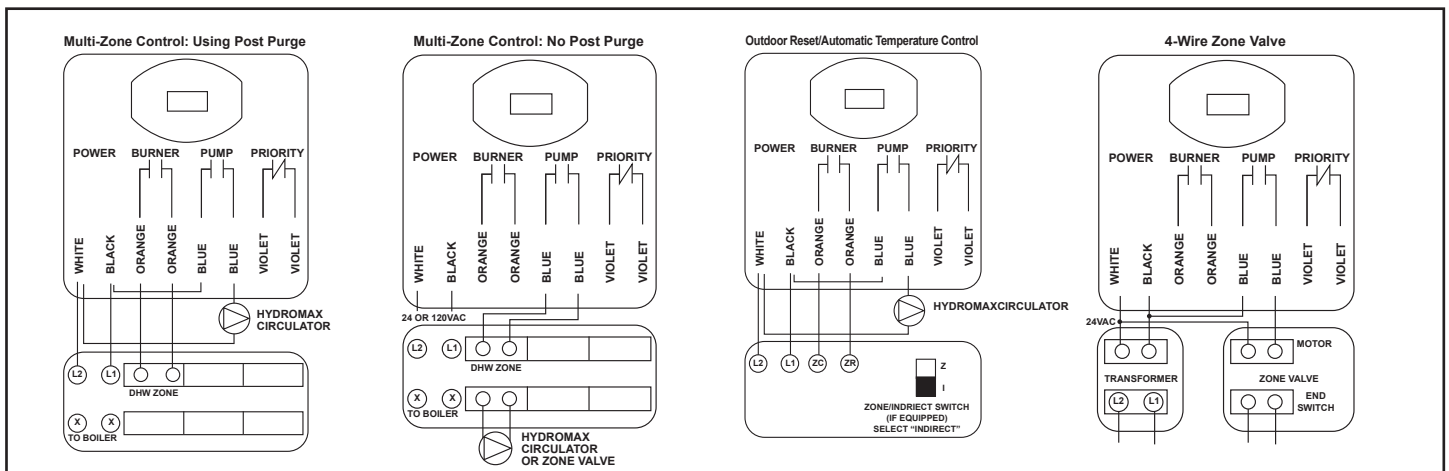

6. Ener-G-NET™ Control Setup & Adjustment

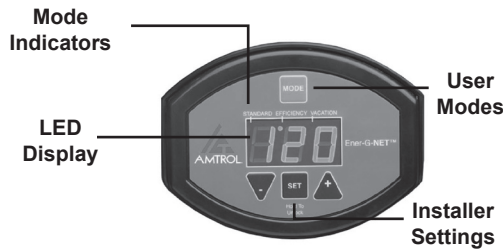

Ener-G-NET features two distinct programming areas: **User Modes** and **Installer Settings**. **User Modes** consist of three end-user functional modes, while **Installer Settings** are primarily accessed upon initial setup to specify critical operating parameters. Ener-G-NET factory defaults allow traditional operation suitable for most homes. To optimize the control setup, reference the tables below.

WARNING Temperature settings above 120° F can create a scald hazard.

User Modes are used to select from three distinct operational modes. To select, press the green **MODE** button and press again to cycle through the three available modes. A green dot illuminates to display the current mode.

User Mode	Code	Description
Standard	5 E D	Traditional operation within preset temperature differential using a low and high limit.
Efficiency	E F F	On-Demand sensing reduces fuel consumption by limiting boiler operation during idle periods.
Vacation	V A C	Reduced temperature setting minimizes boiler operation during anticipated periods of non-use.

Installer Settings are used to adjust functional operating parameters. To adjust, press and hold the **SET** button until the Temperature setting appears. Cycle through settings by depressing the **SET** button and using the ▼ and ▲ buttons to change the settings.

Setting	Code	Description	Range
Temperature	T P	Domestic hot water setpoint. Default is 120°F	90-150
Differential	d i F	Domestic hot water temperature drop before call for heat. Default is 10°F.	5,10*
Post-Purge	P O S	Early boiler shutoff prior to hot water setpoint. Circulator runs until setpoint. Default is 0°F.	0,4,8**
Priority	P r i	Temporarily cancels space heat to maximize available energy for hot water. Default is 'n'.	y/n
Capacity	C A P	Water heater capacity; select appropriate size for proper operation. Default is 41 Gallons.	26,41,60,80,120
BTU Transfer	b t u	Real-time BTU transfer estimate in 1000 BTU/Hr increments. Diagnostic readout only.	0-199MBH/Hr

*Available in Standard Mode only.

**Available only when Differential setting is 10.

Diagnostic Error Codes display a visual indicator and sound an alarm if a fault is detected. Codes clear automatically when corrected or can be reset by interrupting power to the control for 5 seconds. To silence an alarm, depress the ▼ on the keypad.

Error	Code	Description	Potential Causes***
Temp Sensor	E r 1	Temperature sensor (thermistor) fault.	Sensor unplugged Sensor damaged
Overheating	H i E r 2	Domestic hot water temperature has exceeded maximum setpoint.	Error in boiler plumbing Zone valve stuck open Leak in sensor well
Slow Heating	E r 3	Unit has taken over 60 minutes to reach hot water setpoint or cannot reach setpoint.	Faulty equipment Fouled heat exchanger No fuel
Water Alarm	E r 4	Standing water detected.	Standing water

***See Troubleshooting section for additional information

Operating Indicators are used to display operational and functional status. Water sensor temperature may be shown for 30 seconds by pressing the ▲ button.

Indicator	Code	Description
Startup Test	8 8 8	Displayed briefly during initial powerup to test LED display segments.
Idle	1 2 0	Static numeric [setpoint] readout (factory default shown) indicates domestic hot water setpoint.
Heating	O n 1 2 0	Alternating On and [Setpoint] is displayed during a heating cycle while the circulator pump contacts are closed.

7. Mechanical Aquastat Wiring Diagrams

Common wiring diagrams are shown below. Select the appropriate diagram for the application. Diagrams are popular examples only. If your application is not shown, contact Amtrol Technical Support at 401.535.1216.

Boiler Controls

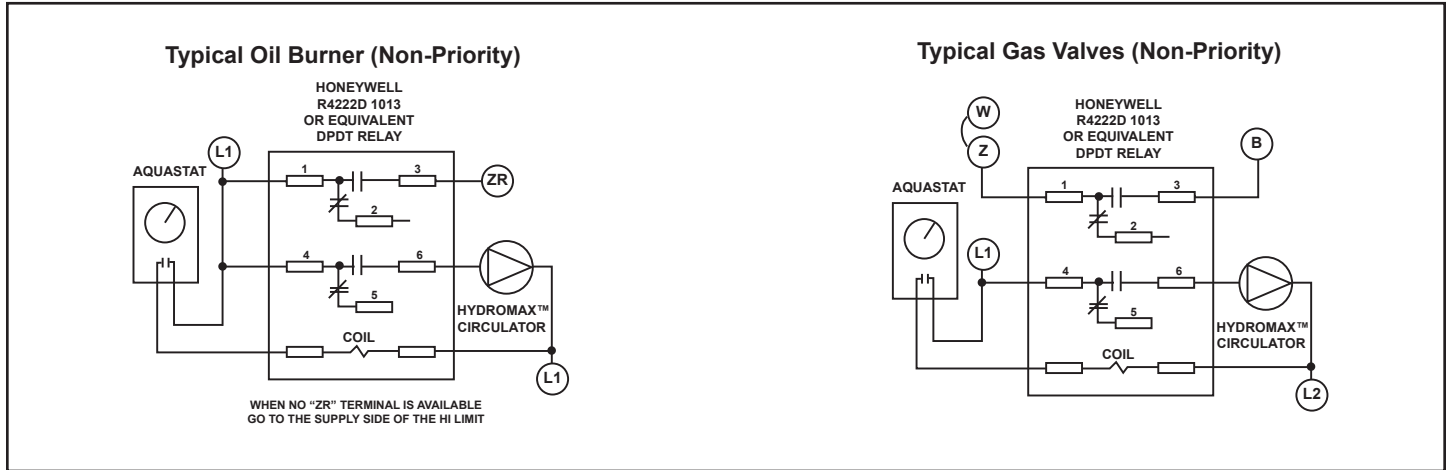

Zone Valves

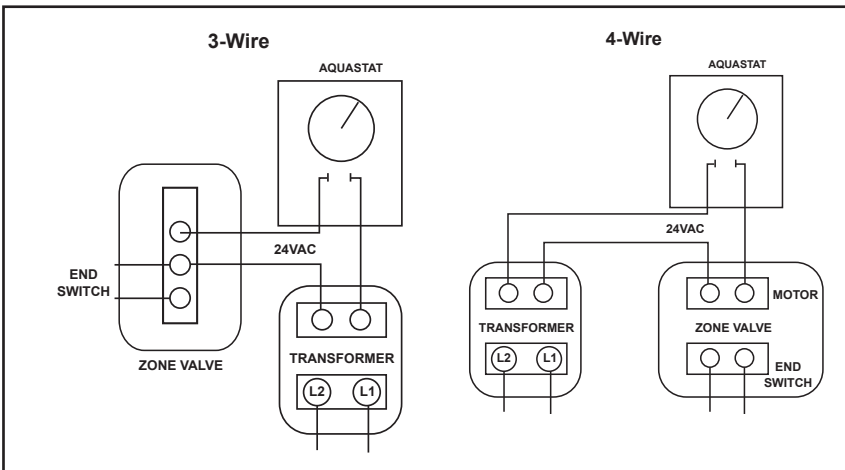

Universal Sensor Kit

Installing Universal 10K Ohm Sensor Kit
 HYDROMAX models with a mechanical aquastat include a universal temperature sensor kit allowing HYDROMAX to be used with any boiler control featuring a standard "10K" DHW thermistor input (10,000 Ohms at 77° F). When installed, domestic water temperature is regulated by the boiler and the HYDROMAX aquastat is not used.

1. Unscrew and remove copper sensor bulb from sensor well.
2. Insert Universal Sensor to bottom of sensor well.
3. Plug Universal Sensor into Extension cable.
4. Connect wire leads to DHW input terminals on boiler control.

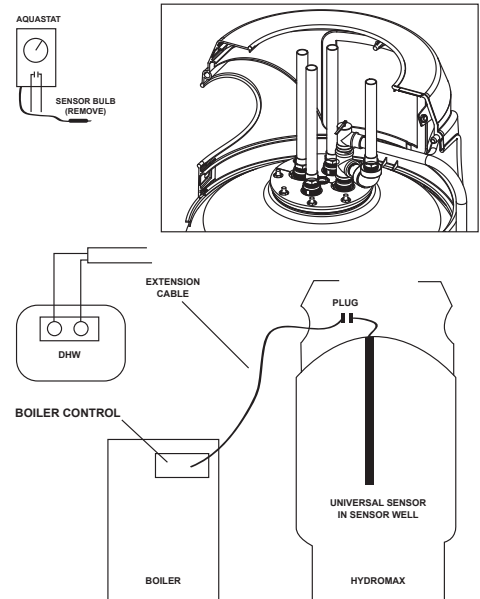

Other Applications

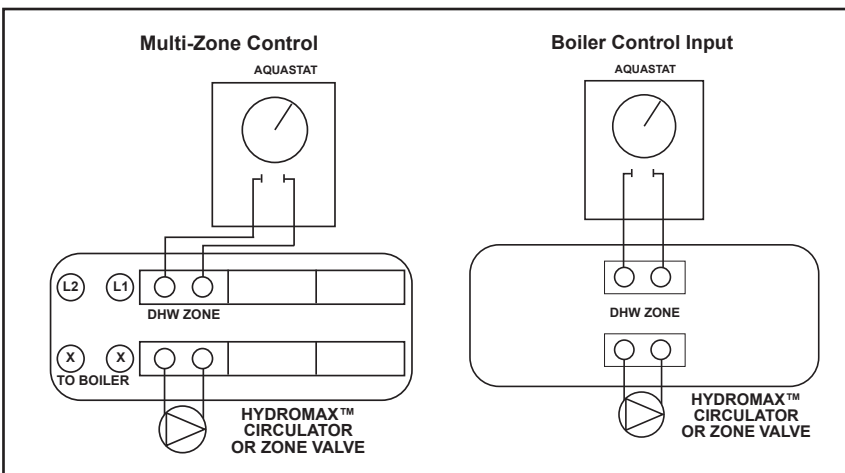

8. Startup Procedure

1. **PURGE HEAT EXCHANGER:** The heat exchanger should be free of large air pockets to allow the circulator to operate properly. Using the diagram below as a guide, isolate the boiler return line and flush the loop until large air pockets are purged. After this, the air elimination equipment will collect smaller air bubbles.
2. **FILL TANK:** Open the hot water fixture furthest from the heater. Open the cold water supply and allow the water to run until air stops emerging. Air pockets may appear at any hot water fixture. This is considered normal and will clear as hot water is used.
3. **START HEATER:** Turn power on to the unit. Digital Control models come pre-set to 120°F for safety. Mechanical controls should have the knob rotated to the 120°F mark. The circulator or zone valve should operate and the boiler should start.
4. **CHECK OPERATION:** The water heater will begin to heat. Depending upon the size of the water heater, output of the boiler and the space heating load, the unit should typically reach set temperature within 15 to 60 minutes. If heating does not occur, consult the troubleshooting section in this manual. **Note:** Large heaters coupled with small boilers may exceed this time period upon initial startup.
5. **SET TEMPERATURE:** The control should be set to the minimum temperature consistent with the user's needs. This maximizes efficiency and reduces scald potential.
6. The water heater and system should be periodically checked by a licensed professional at least annually and more often as system ages.

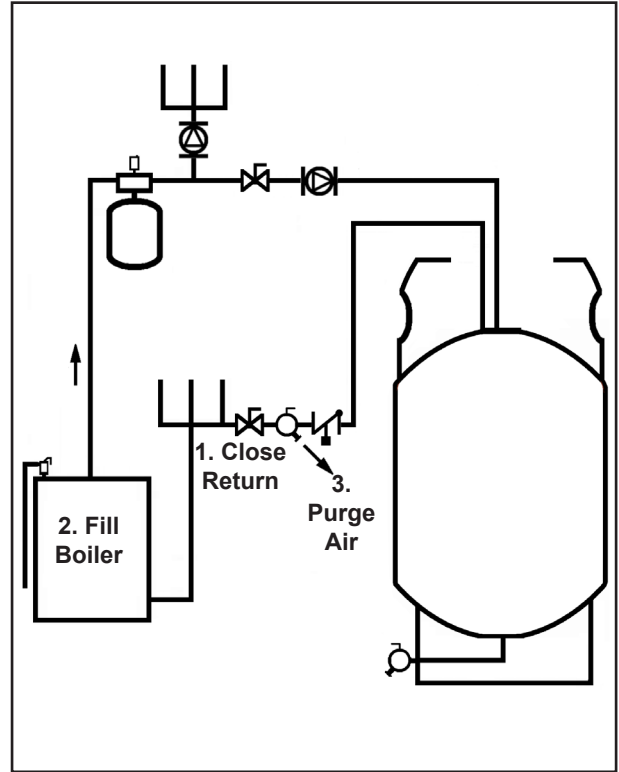

9. Troubleshooting

PROBLEM	POSSIBLE CAUSES	SOLUTION
No hot water	<ol style="list-style-type: none"> 1. No power to unit 2. Circulator air-bound 3. Faulty circulator or zone valve 4. Faulty control 5. Boiler inoperable 	<ol style="list-style-type: none"> 1. Check circuit breaker, boiler emergency switch and boiler reset switch. 2. Purge air. Ensure circulator is on Boiler Supply. Check air vents. 3. Check circulator and zone valve. Repair or replace if necessary. 4. Check continuity. Switching circuits should close. If not, replace control. 5. Check boiler system. Boiler must operate to generate hot water.
Insufficient hot water	<ol style="list-style-type: none"> 1. Demand exceeds capacity 2. Temperature too low 3. Boiler lacks output for simultaneous heat & hot water 4. Fouled heat exchanger 5. Insufficient heat exchanger flow 	<ol style="list-style-type: none"> 1. Check sizing based on household size and boiler output. 2. Increase temperature setpoint. 3. Set up for priority. If problem persists add storage or increase tank size. 4. Check Boiler Supply/Boiler Return during cold startup. If difference is less than 20°F, clean heat exchanger as outlined below. Install water treatment equipment to prevent recurrence. 5. Check for undersized or faulty circulator, stuck or undersized zone valve. Ensure all shutoff valves are open. Check for stuck flow check valve. Purge boiler loop to remove air.
Water too hot	<ol style="list-style-type: none"> 1. Improper plumbing 2. Temperature set too high 3. Temperature sensor not fully inserted 4. Stuck zone valve 5. Flow check valve stuck open 	<ol style="list-style-type: none"> 1. If Boiler Return is plumbed to the suction-side of a heating circulator, overheating will occur when the home's heat is on. Fix plumbing. 2. Reduce temperature setting. 3. Re-insert temperature sensor. 4. Repair or replace. 5. Clean, repair or replace.
Relief valve dripping or opening	<ol style="list-style-type: none"> 1. Thermal expansion tank undersized or missing 2. Thermal expansion tank set improperly 3. City pressure too high 4. System over temperature 5. Faulty relief valve 	<ol style="list-style-type: none"> 1. Install the properly sized thermal expansion tank. 2. Ensure precharge air pressure matches static water pressure. 3. Install a Pressure Reducing Valve (PRV) if city pressure is over 80psi. 4. Determine cause of over temperature condition and correct problem. 5. Replace relief valve.
Discolored water at faucet	<ol style="list-style-type: none"> 1. Poor water quality 2. Sediment or suspended particles 	<ol style="list-style-type: none"> 1. Have water tested for contaminants. 2. Install sediment filter, purge unit more often to avoid future problems.
Boiler will not operate when calling for hot water	<ol style="list-style-type: none"> 1. Improper or loose wiring 2. Boiler high limit has been reached 3. Post Purge (POS) set too high 4. Problem with boiler system 	<ol style="list-style-type: none"> 1. Check connections against wiring diagrams in this manual. 2. Boiler will periodically cycle on and off during operation. 3. Post Purge shuts the boiler off prior to reaching domestic setpoint. If set too high, the boiler may not have enough energy to raise the water temperature to setpoint. Reduce POS or set to 0 if the problem persists. 5. Have boiler diagnosed for proper operation.

10. General Safety Information

⚠ DANGER SCALDING HAZARD. If the water temperature is over 120°F, household members can suffer serious or fatal scalding and painful and permanent injury. • The Consumer Products Safety Commission recommends an initial setting of 120°F, but advised that a slower response time of infants, aged, disabled and other persons increases the scalding hazard and may require lower settings. • Always check the water temperature before use, including washing, bathing or showering. • Temperature limiting valves are available from your plumbing supplier. A check valve must be installed in the boiler return line to prevent gravity flow through the heat exchanger. This can cause overheating and result in serious or fatal scalding.

⚠ DANGER SCALDING HAZARD. If the thermostat is not working properly or if this product is not installed in accordance with the manual, water temperature can reach excessive levels that may cause serious or fatal scalding. After installation and any servicing of the unit, verify that the thermostat is working and firmly inserted in the thermostat well by following the thermostat testing instructions in the manual.

⚠ WARNING Failure to use the correct replacement parts may make your product unsafe.

⚠ WARNING In limited circumstances, space heating can be lost in the home with unit utilizing priority mode. Any demand for space heating is postponed until the water heater has reached its set temperature. This delay in supplying the space heating zones is usually not noticed by the inhabitants of the living spaces. However, in the event of certain malfunctions such as circulator or thermostat failure, space heating could be delayed indefinitely. If undetected and uncorrected, freezing damage to piping could result.

⚠ CAUTION If a steel hydropneumatic tank is in place, replace it with a properly sized diaphragm expansion tank. Otherwise, significant heat transfer problems can occur by causing air to be trapped in the heat exchanger. If the boiler system has a diaphragm expansion tank and the boiler temperatures are being changed, resize the expansion tank.

⚠ WARNING If installing on city water supply, a properly sized thermal expansion tank is required with the water heater and should be installed as set forth in the product installation manual. Contact your water supplier or local plumbing inspector for additional information.

⚠ DANGER Prevent pressure build-up in any existing internal tankless coil. Do not plug incoming or outgoing tapings in the internal tankless coil plate. Leave the coil in the boiler and leave system connections open to prevent pressure build-up.

⚠ DANGER **Electrocution hazard.** The water heater must be electrically grounded. Electrical supply must come from the boiler side of boiler's emergency shut-off switch in order to prevent unsafe boiler operation.

⚠ WARNING **Chlorine Aggressive Water:** The water quality can significantly influence the life of this Product. You should test for corrosive elements, acidity, total solids and other relevant contaminants, including chlorine and treat your water appropriately to insure satisfactory performance and prevent premature failure.

Note: Inspect for shipping damage and notify freight carrier or store where purchased immediately if damage is present. To avoid risk of personal injury and property damage, if the product appears to be malfunctioning or shows signs of corrosion, call a qualified professional immediately. Current copies of the Product Manual can be obtained at the place of purchase. Use proper safety equipment when installing.

⚠ DANGER **EXPLOSION HAZARD.** The pressure of the heat transfer medium must be limited to a maximum of 30 psig by an approved safety or relief valve on your boiler. The water heater pressure must be limited to 150 psig maximum by the installation of a temperature and pressure relief valve (included). The relief tube must be plumbed to a suitable drain per code. No reducing coupling or other restriction may be placed in this line.

⚠ WARNING This Product, like most Products under pressure, may over time corrode, weaken and burst or explode, causing serious or fatal injury, leaking or flooding and/or property damage. To minimize risk, a licensed professional must install and periodically inspect and service the Product. A drip pan connected to an adequate drain must be installed if leaking or flooding could cause property damage. Do not locate in an area where leaking could cause property damage to the area adjacent to the appliance or to lower floors of the structure.

⚠ WARNING **EXPLOSION OR RUPTURE HAZARD.** A relief valve must be installed to prevent pressure in excess of local code requirement or maximum working pressure designated in the Product Manual, whichever is less. Do not expose Product to freezing temperatures or temperatures in excess of the maximum rated operating temperature.

⚠ DANGER If not installed by the boiler manufacturer, install a low water cut-off or pressure reducing valve on your boiler so that leaking will not result in a dry boiler which if the boiler continues to fire, will cause an explosion hazard.

⚠ DANGER This unit must be installed as a separate heating zone. Do not connect this unit to an existing heating zone or feed boiler water directly through the coil as dangerous over-heating will result.

⚠ CAUTION Do not drain this appliance before shutting off the supply valve and opening the relief valve or another downstream fixture, as it will damage this unit. A vacuum breaker should be installed to avoid damaging the liner. Damage to the unit and leakage can occur if a vacuum breaker is not installed.

⚠ WARNING **USE GLYCOL ONLY WITH DOUBLE-WALLED HEAT EXCHANGER MODELS.** Avoid risk of ingesting a toxic glycol fluid. The heat transfer medium should be water. If glycol must be used, it should only be used with double-walled heat exchangers and closely monitored for leakage.

⚠ WARNING **CALIFORNIA PROPOSITION 65 WARNING!** This product contains a chemical known by the State of California to cause cancer and to cause birth defects or other reproductive harm. (California Installer/Contractor - California law requires that this notice be given to consumer/end user of this product.) For more information: www.amtrol.com/prop65.htm

⚠ CAUTION As in all plumbing products and water storage vessels, bacteria can grow in this Product, especially during times of non-use. Consult your local plumbing professional regarding any steps you may wish to take to safely disinfect your home's plumbing system.

⚠ WARNING **EXPLOSION OR RUPTURE HAZARD!** A relief valve must be installed to prevent pressure in excess of local code requirement or maximum working pressure designated in the Product Manual, whichever is less. At least once every 3 years or if discharge is present, a licensed contractor should inspect the temperature and pressure relief valve and replace if corrosion is evident or the valve does not function. **FAILURE TO INSPECT THIS VALVE AS DIRECTED COULD RESULT IN UNSAFE TEMPERATURE OR PRESSURE BUILD-UP WHICH CAN RESULT IN PRODUCT FAILURE, SERIOUS INJURY OR DEATH AND/OR SEVERE PROPERTY DAMAGE AND VOID THE PRODUCT WARRANTY.**

11. REPLACEMENT PARTS

Description	ID	HM-41 Models	HM-80 Models
Heat Exchanger Replacement Kit, Single Wall	1	2713R002	2712R002
Heat Exchanger Replacement Kit, Double Wall	1	2800R001	2801R001
Top Cover Half (2 Required)	2	2704R512	2704R512
Mounting Panel, Digital Control	3	2704R525	2704R525
Mounting Panel, Mechanical Control	4	2704R498	2704R498
Ener-G-NET™ Digital Temperature Control	5	940R2	940R2
Temperature Sensor (Thermistor)	-	2704-259	2704-259
Water Sensor	-	2704-495	2704-495
Mechanical Temperature Control	6	2704-093	2704-093
Universal 10K Sensor Kit	-	2704-529	2704-529
Turbulator™ Cold Water Inlet Tube	7	2783R0003	2782R0001
T&P Safety Relief Valve	8	2700R116	2700R116
T&P Blowdown Tube	9	2783R004	2782R002
Bottom Drain Assembly	10	9340R160	9340R160

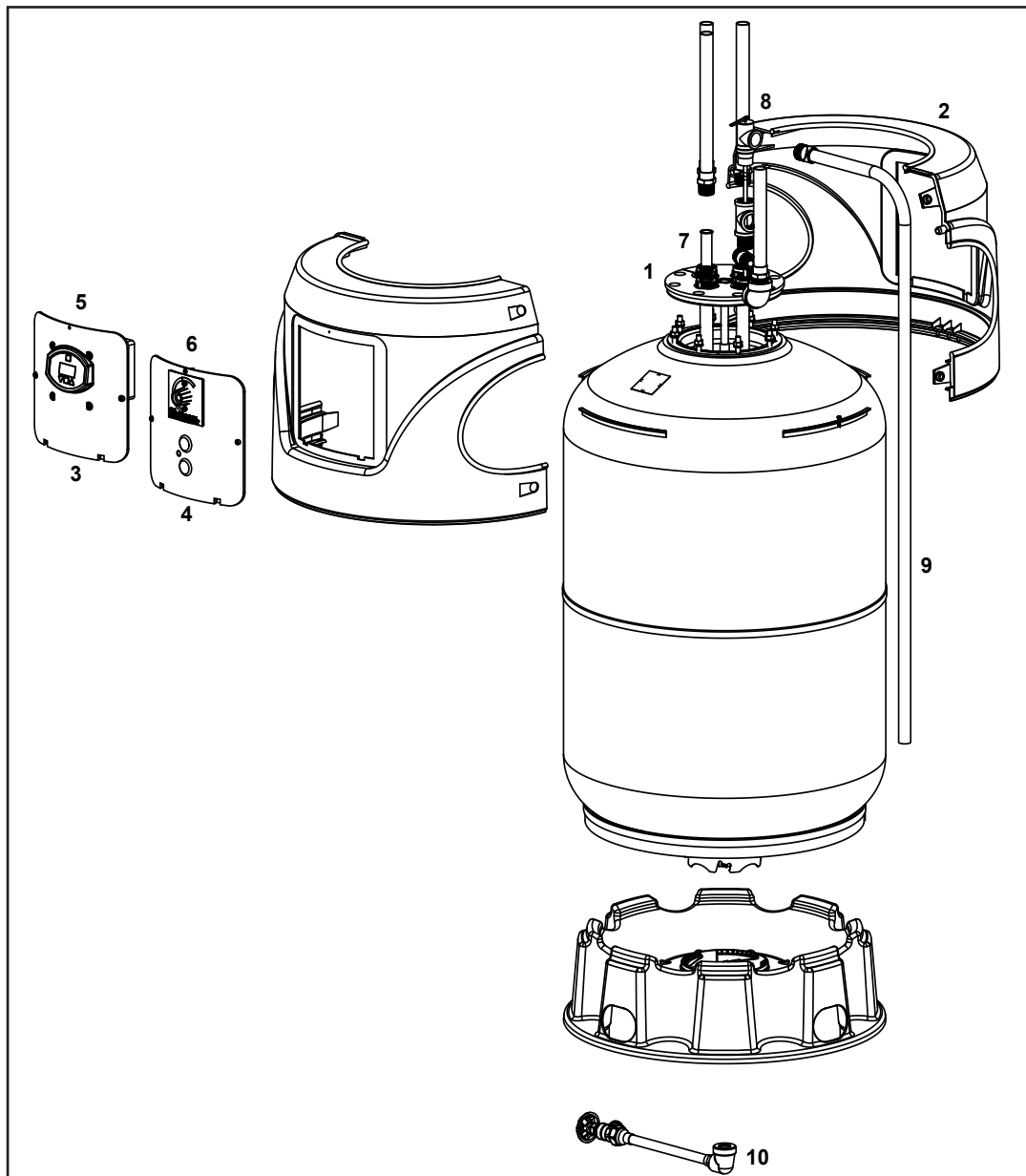



1400 Division Road, West Warwick, RI 02893 ▲ T: 401.884.6300 ▲ F: 401.885.2567 ▲ www.amtrol.com

HYDROMAX, Ener-G-NET, AMTROL, AMTROL logo, Therm-X-Trol, and EXTROL are registered trademarks of AMTROL Inc. and affiliates in the U.S. and elsewhere. All rights reserved.