

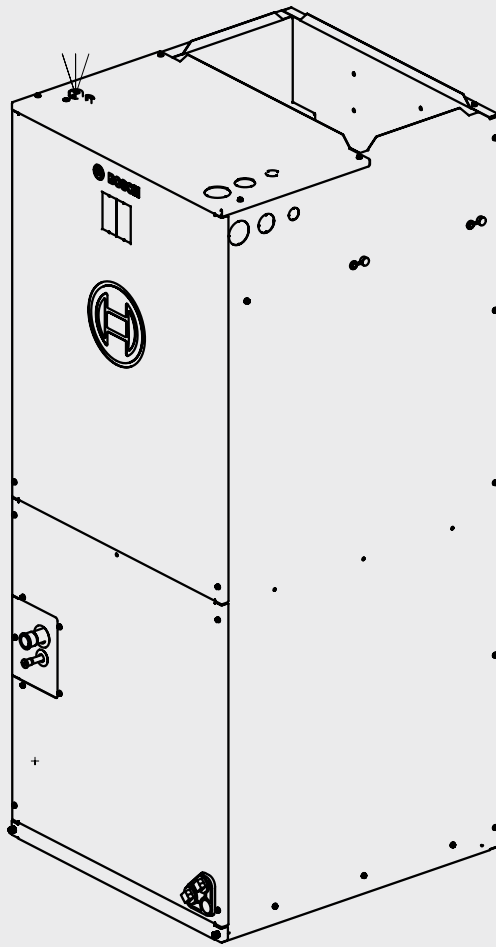

Installation and Operating Instructions

# Bosch IDS Heat Pump Ultra Series Air Handler

3-5 Ton Capacity | R-454B



BTC 762003306 H / 02.2026





**Table of Contents**

<b>1</b>	<b>Key to Symbols and Safety Instructions</b>	<b>4</b>
1.1	Key to Symbols	4
1.2	Explanation of Symbols Displayed on the Unit	4
1.3	Safety	4
<b>2</b>	<b>General</b>	<b>10</b>
2.1	Installations in High Humidity Environments	10
2.2	Unit Dimensions	13
2.3	Components	14
2.4	A2L Refrigerant Sensor	15
<b>3</b>	<b>Applications</b>	<b>16</b>
3.1	Vertical Upflow	16
3.2	Vertical Downflow	16
3.3	Horizontal	16
3.4	Installation in an Unconditioned Space	18
3.5	Refrigerant Charge and Room Area Limitations	19
3.5.1	The Room Area Calculation Requirements	19
3.5.2	The Allowed Maximum Refrigerant Charge and Required Minimum Room Area	21
<b>4</b>	<b>Electrical Wiring</b>	<b>24</b>
4.1	Power Wiring	24
4.2	Control Wiring	25
4.3	Grounding	25
4.4	Electrical Data	25
4.5	Electric Heat Kit MCA/MOP Data	26
<b>5</b>	<b>Airflow Performance</b>	<b>28</b>
5.1	Indoor Fan Motor Function	29
<b>6</b>	<b>Ductwork</b>	<b>30</b>
<b>7</b>	<b>Refrigerant Connections</b>	<b>31</b>
<b>8</b>	<b>Condensate Drain Connection</b>	<b>32</b>
<b>9</b>	<b>Air Filter (Not Factory-Installed)</b>	<b>34</b>
9.1	Filter Installation Dimensions	35
<b>10</b>	<b>Maintenance</b>	<b>36</b>
10.1	Cleaning Precautions	36
10.2	Regular Maintenance	36
<b>11</b>	<b>Disposal</b>	<b>36</b>
<b>12</b>	<b>Wiring Diagrams</b>	<b>37</b>
12.1	Communicating Set Up	38
<b>13</b>	<b>LED Flashing Troubleshooting</b>	<b>43</b>

## 1 Key to Symbols and Safety Instructions

### 1.1 Key to Symbols

#### Warnings

In warnings, signal words at the beginning of a warning are used to indicate the type and seriousness of the ensuing risk if measures for minimizing danger are not taken.

The following keywords are defined and can be used in this document:

**DANGER**  
**DANGER** indicates a hazardous situation which, if not avoided, will result in death or serious injury.

**WARNING**  
**WARNING** indicates a hazardous situation which, if not avoided, could result in death or serious injury.

**CAUTION**  
**CAUTION** indicates a hazardous situation which, if not avoided, could result in minor to moderate injury.

**NOTICE**  
**NOTICE** is used to address practices not related to personal injury.

#### Important information

The info symbol indicates important information where there is no risk to people or property.

### 1.2 Explanation of Symbols Displayed on the Unit

Symbol	
	<b>WARNING</b> This symbol shows that this appliance used a flammable refrigerant. If the refrigerant is leaked and exposed to an external ignition source, there is a risk of fire.
	<b>WARNING</b> This symbol shows that appliance shall be installed, operated and stored in a room with a floor area not less than the minimum room area.
	<b>CAUTION</b> This symbol shows that the operation manual should be read carefully.
	<b>CAUTION</b> This symbol shows that a service personnel should be handling this equipment with reference to the installation manual.
	<b>CAUTION</b> This symbol shows that information is available such as the operating manual or installation manual.
	<b>CAUTION</b> This symbol shows that when addition of charge is required by the manufacturer installation instructions for completing the REFRIGERATING SYSTEM. Recorded the resulting total REFRIGERANT CHARGE for each REFRIGERATING SYSTEM.

Table 1

### 1.3 Safety

#### Please read safety precautions before installation

**WARNING**  
**Improper or dangerous operation!**

These instructions are intended as an aid to qualified licensed service personnel for proper installation, adjustment and operation of this unit. Read these instructions thoroughly before attempting installation or operation. Failure to follow these instructions may result in improper installation, adjustment, service or maintenance and possibly resulting in fire, electrical shock, property damage, personal injury or death.

This document is customer property and is to remain with this unit. These instructions do not cover all the different variations of systems nor does it provide for every possible contingency to be met in connection with installation.

**WARNING**  
**Fire, electrical shock, property damage, personal injury, or death!**  
 All phases of this installation must comply with NATIONAL, STATE AND LOCAL CODES. If additional information is required please contact your local distributor.

**WARNING**

**Fire, electrical shock, property damage, personal injury, or death!**

All phases of this installation must comply with NATIONAL, STATE AND LOCAL CODES. If additional information is required please contact your local distributor.

**WARNING**

**Electrical shock!**

Disconnect all power to unit before installing or servicing. More than one disconnect switch may be required to deenergize the equipment. Hazardous voltage can cause severe personal injury or death.

**WARNING**

**Electrical shock!**

If removal of the blower assembly is required, all disconnect switches supplying power to the equipment must be deenergized and locked (if not in sight of unit) so the field power wires can be safely removed from the blower assembly. Failure to do so can cause electrical shock resulting in personal injury or death.

**WARNING**

**Fire, electrical shock, property damage, personal injury, or death!**

Because of possible damage to equipment or personal injury, installation, service, and maintenance should be performed by trained, qualified service personnel. Consumer service is recommended only for filter cleaning / replacement. Never operate the unit with the access panels removed.

**WARNING**

**Electrical shock!**

The unit must be permanently grounded. Failure to do so can result in electrical shock causing personal injury or death.

**CAUTION**

**Fire, personal injury, property damage!**

The first 6 inches of supply air plenum and ductwork must be constructed of sheet metal as required by NFPA 90B. The supply air plenum or duct must have a solid sheet metal bottom directly under the unit with no openings, registers or flexible air ducts located in it. If flexible supply air ducts are used, they may be located only in the vertical walls of rectangular plenum, a minimum of 6 inches from the solid bottom. Metal plenum or duct may be connected to the combustible floor base, if not, it must be connected to the unit supply duct exposed to the supply air opening from the downflow unit. Exposing combustible (non-metal) material to the supply opening of a downflow unit can cause a fire resulting in property damage, personal injury or death.

**NOTICE**

**Product damage!**

Make sure the blower motor support is tight (3-motor mounting bolts - Figure 1). Then check if wheel is tightly secured to motor shaft before operating unit.

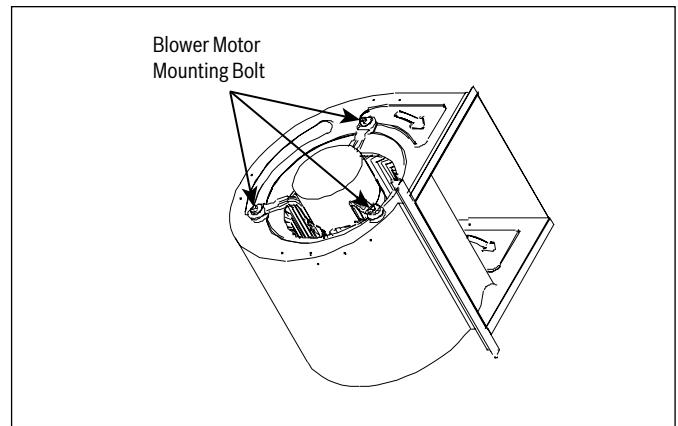

Figure 1

**WARNING**

**Personal injury!**

- PROPOSITION 65: This appliance contains fiberglass insulation. Respirable particles of fiberglass are known to State of California to cause cancer.
- All manufacturer products meet current federal OSHA Guidelines for safety. California Proposition 65 warnings are required for certain products, which are not covered by the OSHA standards.
- California's Proposition 65 requires warnings for products sold in California that contain or produce any of over 600 listed chemicals known to the State of California to cause cancer or birth defects such as fiberglass insulation, lead in brass, and combustion products from natural vapor.
- All "new equipment" shipped for sale in California will have labels stating that the product contains and/or produces Proposition 65 chemicals. Although we have not changed our processes, having the same label on all our products facilitates manufacturing and shipping. We cannot always know "when, or if" products will be sold in the California market.
- You may receive inquiries from customers about chemicals found in, or produced by, some of our heating and air-conditioning equipment, or found in natural vapor used with some of our products.
- Listed below are those chemicals and substances commonly associated with similar equipment in our industry and other manufacturers.
  - Glass Wool (Fiberglass) Insulation
  - Carbon Monoxide (CO)
  - Formaldehyde
  - Benzene
- More details are available on the following websites: OSHA (Occupational Safety and Health Administration), at [www.osha.gov](http://www.osha.gov) and the State of California's OEHHA (Office of Environmental Health Hazard Assessment), at [www.oehha.org](http://www.oehha.org). Consumer education is important since the chemicals and substances on the list are found in our daily lives. Most consumers are aware that products present safety and health risks, when improperly used, handled and maintained.

 **WARNING**
**Flammable refrigerant!**

Do not use means to accelerate the defrosting process or to clean, other than those recommended by the manufacturer.

The appliance shall be stored in a room that does not have continuously operating ignition sources (for example: open flames, an operating gas appliance or an operating electric heater).

Do not pierce or burn the unit.

Be aware that refrigerants may not contain an odour.

If refrigerant gas leaks during installation, ventilate the area immediately.

Comply with national gas regulations.

**NOTICE****Product damage!**

Only use this unit in well-ventilated spaces and ensure that there are no obstructions that could impede the airflow into and out of the unit. Do not use this unit in the following locations:

- Locations with mineral oil.
- Locations with saline atmospheres, such as seaside locations.
- Locations with sulphurous atmospheres, such as near natural hot springs.
- Where high voltage electricity is present, such as in certain industrial locations.
- On vehicles or vessels, such as trucks or ferry boats.
- Where exposure to oily or very humid air may occur, such as kitchens.
- In proximity to sources of electromagnetic radiation, such as high-frequency transmitters or other high strength radiation devices.

 **WARNING**
**Personal injury, product damage!**

This appliance is not intended for use by persons (including children) with reduced physical, sensory or mental capabilities, or persons who lack experience and knowledge, unless they are supervised or have been given instructions concerning the use of the appliance by a person responsible for their safety.

Children should be supervised to ensure that they do not play with the appliance.

Any person who is involved with working on or opening a refrigerant circuit should hold a current valid certificate from an industry-accredited assessment authority, which authorizes their competence to handle refrigerants safely in accordance with an industry recognized assessment credential.

Servicing shall only be performed as recommended by the equipment manufacturer.

Maintenance and repair requiring the assistance of other skilled personnel shall be carried out under the supervision of a person competent in the use of flammable refrigerants.

Prior to beginning work on systems containing flammable refrigerants, safety checks are necessary to minimize the risk of ignition.

 **WARNING**
**Electric shock, personal injury, product damage!**

Be sure the air conditioner is grounded. In order to avoid electric shock, make sure that the unit is grounded and that the ground wire is not connected to a gas or water pipe, lightning conductor or telephone earth wire.

Do not operate the air conditioner with a wet hands. An electric shock may happen.

Do not touch the heat exchanger fins. These fins are sharp and could cut you.

To avoid oxygen deficiency, ventilate the room sufficiently if equipment with a burner is used together with the air conditioner.

Arrange the drain hose to ensure smooth drainage. Incomplete drainage may cause wetting of the building, furniture, etc.

Never touch the internal parts of the controller.

Do not remove the blower access panel. Some parts inside are dangerous to touch, and machine troubles may occur.

Attention is drawn to the fact that additional transportation regulations may exist with respect to equipment containing flammable gas. The maximum number of pieces of equipment or the configuration of the equipment permitted to be transported together will be determined by the applicable transport regulations.

Signs for similar appliances used in a work area are generally addressed by local regulations and give the minimum requirements for the provision of safety and/or health signs for a work location. All required signs are to be maintained and employers should ensure that employees receive suitable and sufficient instruction and training on the meaning of appropriate safety signs and the actions that need to be taken in connection with these signs.

The effectiveness of signs should not be diminished by too many signs being placed together.

Any pictograms used should be as simple as possible and contain only essential details.

The storage of the appliance should be in accordance with the applicable regulations or instructions, whichever is more stringent.

Storage package protection should be constructed such a way that mechanical damage to the equipment inside the package will not cause a leak of the REFRIGERANT CHARGE.

The maximum number of pieces of equipment permitted to be stored together will be determined by local regulations.

Do not operate the air conditioner when using a room fumigation - type insecticide. Failure to observe this precaution could cause the chemicals to become deposited in the unit, which could endanger the health of those who are hypersensitive to chemicals. It may also cause the refrigerant sensor to alarm.

Do not place appliances which produce open flame in places exposed to the air flow from the unit or under the indoor unit. It may cause incomplete combustion or deformation of the unit due to the heat.

Do not install the air conditioner in a location where flammable gas may leak out. If the gas leaks out and stays around the air conditioner, a fire may occur.

 **WARNING**
**Personal injury!**

The unit must be permanently grounded. Failure to do so may result in electrical shock causing personal injury or death.

**WARNING**
**Personal Injury, flammable refrigerant!**

When repairing the refrigerating system, comply with the following precautions prior to conducting work on the system:

- Work shall be undertaken according to controlled procedures to minimize the risk of the presence of flammable gases or vapors while the work is being performed.
- All maintenance staff and others working in the local area shall be instructed on the nature of work being carried out. Work in confined spaces shall be avoided.
- The area shall be checked with an appropriate refrigerant detector prior to and during work, to ensure the technician is aware of potentially toxic or flammable environment. Ensure that the leak detection equipment being used is suitable for use with all applicable refrigerants, i.e., non-sparking, adequately sealed or intrinsically safe.
- If any hot work is to be conducted on the refrigerating equipment or any associated parts, appropriate fire extinguishing equipment shall be available and easily accessible. Have a dry powder or CO2 fire extinguisher adjacent to the charging area.
- When carrying out work in relation to a refrigerating system that involves exposing any pipe work, no sources of ignition shall be used in such a manner that it may lead to the risk of fire or explosion. All possible ignition sources, including cigarette smoking, should be kept sufficiently far away from the site of installation, repair, or removal and disposal of the unit, during which refrigerant can possibly be released into the surrounding space. Prior to beginning work, the area around the equipment is to be surveyed to make sure that there are no flammable hazards or ignition risks. "No Smoking" signs shall be clearly displayed.

**WARNING**
**Personal Injury, flammable refrigerant!**

Ensure that the area is in the open or that it is adequately ventilated before opening the system or conducting any hot work. A degree of ventilation shall continue during the period that the work is carried out. The ventilation should safely disperse any released refrigerant and preferably expel it externally into the surroundings.

Where electrical components are being changed, they shall be fit according to their purpose and to the correct specification. At all times the manufacturer's maintenance and service guidelines shall be followed. If in doubt, consult the manufacturer's technical department for assistance. The following checks shall be applied to installations using flammable refrigerants:

- The actual refrigerant charge is in accordance with the room size within which the refrigerant containing parts are installed.
- The ventilation machinery and outlets are operating adequately and are not obstructed.
- If an indirect refrigerating circuit is being used, the secondary circuit shall be checked for the presence of refrigerant.
- Equipment marking must remain visible and legible. Markings and signs that are illegible shall be corrected.

**WARNING**
**Personal Injury, flammable refrigerant!**

Refrigerating pipe or components are installed in a position where they are unlikely to be exposed to any substances which may corrode refrigerant containing components, unless the components are constructed of materials that are inherently resistant to corrosion or are suitably protected against corrosion.

Repair and maintenance of electrical components shall include initial safety checks and component inspection procedures. If a fault exists that could compromise safety, then no electrical supply shall be connected to the circuit until the fault has been dealt with.

- That capacitors are discharged: this shall be done in a safe manner to avoid the possibility of sparking.
- That no live electrical components and wiring are exposed while charging, recovering or purging the system.
- That there is continuity of grounding.

**WARNING**
**Flammable refrigerant!**

Sealed electrical components shall be replaced.

Intrinsically safe components must be replaced.

Check that cabling will not be subject to wear, corrosion, excessive pressure, vibration, sharp edges or any other adverse environmental effects. The check shall also take into account the effects of aging or continual vibration from sources such as compressors or fans.

Under no circumstances shall potential sources of ignition be used while searching for or detection of refrigerant leaks. A halide torch (or any other detector using a naked flame) shall not be used.

Electronic leak detectors may be used to detect refrigerant leaks but, in the case of flammable refrigerants, the sensitivity may not be adequate, or may need re-calibration. (Detection equipment shall be calibrated in a refrigerant-free area.) Ensure that the detector is not a potential source of ignition and is suitable for the refrigerant used. Leak detection equipment shall be set at a percentage of the LFL of the refrigerant and shall be calibrated for the refrigerant employed, and the appropriate percentage of gas (25 % maximum) is confirmed.

If a leak is suspected, all naked flames shall be removed/extinguished.

If a leakage of refrigerant which requires brazing is found, all of the refrigerant shall be recovered from the system, or isolated (by means of shut off valves) in a part of the system remote from the leak.

Leak detection fluids are also suitable for use with most refrigerants but the use of detergents containing chlorine shall be avoided as the chlorine may react with the refrigerant and corrode the copper pipe-work.

Examples of leak detection fluids are:

- bubble method,
- fluorescent method agents.

 **WARNING**
**Flammable refrigerant!**

When breaking into the refrigerant circuit to make repairs or for any other purpose conventional procedures shall be used. However, for flammable refrigerants it is important that best practice be followed, since flammability is a consideration. The following procedure shall be adhered to:

- safely remove refrigerant following local and national regulations.
- evacuate.
- purge the circuit with inert gas.
- evacuate.
- continuously flush or purge with inert gas when using flame to open circuit, and,
- open the circuit.

The refrigerant charge shall be recovered into the correct recovery cylinders if venting is not allowed by local and national codes. For appliances containing flammable refrigerants, the system shall be purged with oxygen-free nitrogen to render the appliance safe for flammable refrigerants. This process might need to be repeated several times. Compressed air or oxygen shall not be used for purging refrigerant systems.

For appliances containing flammable refrigerants, refrigerants purging shall be achieved by breaking the vacuum in the system with oxygen-free nitrogen and continuing to fill until the working pressure is achieved, then venting to atmosphere, and finally pulling down to a vacuum. This process shall be repeated until no refrigerant is within the system. When the final oxygen-free nitrogen charge is used, the system shall be vented down to atmospheric pressure to enable work to take place.

The outlet for the vacuum pump shall not be close to any potential ignition sources, and ventilation shall be available.

Ensure that contamination of different refrigerants does not occur when using charging equipment. Hoses or lines shall be as short as possible to minimize the amount of refrigerant they contain.

Cylinders shall be kept upright. Ensure that the refrigeration system is grounded prior to charging the system with refrigerant.

Label the system when charging is complete (if it is not already labeled).

Take extreme care not to overfill the refrigeration system.

 **WARNING**
**Flammable refrigerant!**

Prior to recharging the system, it shall be pressure-tested with the appropriate purging gas. The system shall be leak-tested on completion of charging but prior to commissioning. A follow up leak test shall be carried out prior to leaving the site.

Before carrying out this procedure, it is essential that the technician is completely familiar with the equipment and all its detail. It is recommended that all refrigerants are recovered safely. Prior to the task being carried out, an oil and refrigerant sample shall be taken in case analysis is required prior to re-use of reclaimed refrigerant. It is essential that electrical power is available before the task is commenced.

- a. Become familiar with the equipment and its operation.
- b. Isolate system electrically.
- c. Before attempting the procedure ensure that:
  - mechanical handling equipment is available, if required, for handling refrigerant cylinders.
  - all personal protective equipment is available and being used correctly.
  - the recovery process is supervised at all times by a competent person.
  - recovery equipment and cylinders conform to the appropriate standards.
- d. Pump down refrigerant system, if possible.
- e. If a vacuum is not possible, make a manifold so that refrigerant can be removed from various parts of the system.
- f. Make sure that the cylinder is situated on the scales before recovery takes place.
- g. Start the recovery machine and operate it in accordance with the manufacturer's instructions.
- h. Do not overfill cylinders. (No more than 80% volume liquid charge).
- i. Do not exceed the maximum working pressure of the cylinder, even temporarily.
- j. When the cylinders have been filled correctly and the process has been completed, make sure that the cylinders and the equipment are removed from site promptly and all isolation valves on the equipment are closed off.
- k. Recovered refrigerant shall not be charged into another refrigeration system unless it has been cleaned and checked.

Equipment shall be labeled stating that it has been de-commissioned and emptied of refrigerant. The label shall be dated and signed. Ensure that there are labels on the equipment stating the equipment contains flammable refrigerant.

When removing refrigerant from a system, either for servicing or decommissioning, it is recommended that all refrigerants are removed safely.

When transferring refrigerant into cylinders, ensure that only appropriate refrigerant recovery cylinders are employed. Ensure that the correct number of cylinders for holding the total system charge is available. All cylinders to be used are designated for the recovered refrigerant and labelled for that refrigerant (i.e. special cylinders for the recovery of refrigerant). Cylinders shall be complete with pressure-relief valve and associated shut-off valves in good working order. Empty recovery cylinders are evacuated and, if possible, cooled before recovery occurs.

 **WARNING**

**Flammable refrigerant!**

The recovery equipment shall be in good working order with a set of instructions concerning the equipment that is at hand and shall be suitable for the recovery of the flammable refrigerant. If in doubt, the manufacturer should be consulted. In addition, a set of calibrated weighing scales shall be available and in good working order. Hoses shall be complete with leak-free disconnect couplings and in good condition.

The recovered refrigerant shall be processed according to local legislation in the correct recovery cylinder, and the relevant waste transfer note arranged. Do not mix refrigerants in recovery units and especially not in cylinders.

If compressors or compressor oils are to be removed, ensure that they have been evacuated to an acceptable level to make certain that flammable refrigerant does not remain within the lubricant. The compressor body shall not be heated by an open flame or other ignition sources to accelerate this process. When oil is drained from a system, it shall be carried out safely.

Do not use the air conditioner for other purposes. In order to avoid any quality deterioration, do not use the unit for the cooling of precision instruments, food, plants, animals or works of art. Before cleaning, be sure to stop the operation, turn the breaker off or unplug the supply cord. Otherwise, electric shock and injury may occur.

To avoid electric shock or fire, make sure that a leak detector is installed. Never touch the air outlet or the horizontal blades while the swing flap is in operation. Fingers may be come caught or the unit may break down.

Never put any objects into the air inlet or outlet. Objects touching the fan at high speed can be dangerous. Never inspect or service the unit by yourself. Ask a qualified service person to perform this task.

Do not dispose of this product as unsorted municipal waste. This waste should be collected separately for special treatment. Do not dispose of electrical appliances as unsorted municipal waste. Use separate collection facilities. Contact your local government for information regarding the connection systems available.

If electrical appliances are disposed of in landfills or dumps, hazardous substances can leak into the groundwater and get into the food chain, hazardous to one's health and well-being.

To prevent refrigerant leak, contact your dealer.

When the system is installed and operates in a small room, it is required to maintain the concentration of the refrigerant below the limit, in case a leak occurs. Otherwise, oxygen in the room may be affected, resulting in a serious accident.

The refrigerant in the air conditioner is safe and normally does not leak.

If the refrigerant leaks into the room and encounters the fire of a burner, a heater or a cooker, a harmful gas could be released.

Turn off any combustible heating devices, ventilate the room, and contact the dealer where the unit was purchased.

Do not use the air conditioner until a service person confirms that the refrigerant leak is repaired.

Keep ventilation openings clear of obstruction.

 **WARNING**

**Flammable refrigerant!**

The appliance uses R-454B refrigerant.



## 2 General

The unit can be positioned for bottom air return in the upflow position, left and right air return in the horizontal position and top air return in downflow position.

This air handler provides the flexibility for installation in any upflow, downflow or horizontal application. Adjust the motor speed tap through the DIP switch (located on the Air Handler's control board) to select correct air flow according to airflow performance table (Table 14). Please refer to wiring diagram for Dip Switch settings.

**WARNING**

**Fire hazard!**

Do not install unit in an area where flammable materials are present due to the risk of an explosion resulting in serious injury or death.

**WARNING**

**Personal injury, product damage!**

If the supporting structural members are not strong enough to take the unit's weight, the unit could fall out of place and cause serious injury.

If a return-air duct is not installed, carefully select the place and method of product installation so that air flow into the product will not be blocked.

The unit should be installed in a level position to ensure proper condensation drainage. Up to an additional ¼" rise over the width or depth of the unit is allowed to create additional sloping towards the drain.

Install the indoor and outdoor unit, power supply wiring and connecting wires at least 3.5 ft. away from televisions or radios in order to prevent image interference or noise.

Please refer to Figure 32 for high and low voltage wiring connections.

To ensure the proper installation, select a solid and level site. Ensure enough clearance is maintained for installation and maintenance. Refer to Figure 2.

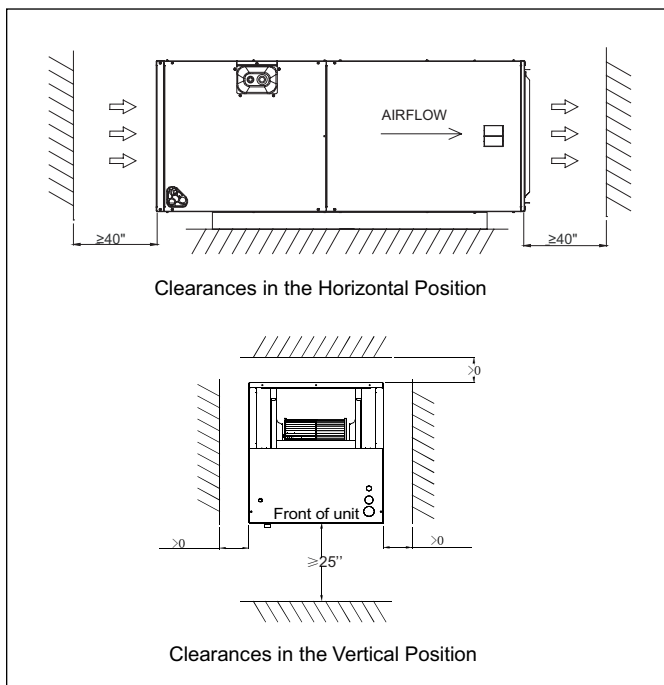

Figure 2 Required clearances

**NOTICE**

**Product damage!**

The installed unit must have the required clearances as shown in Figure 2. Failure to follow these instructions may result in equipment damage and/or premature equipment failure.

**WARNING**

**Fire hazard!**

Keep flammable material and vapors, such as gasoline, away from the air handler. Failure to follow these instructions can result in death, explosion, or fire.

### 2.1 Installations in High Humidity Environments

When the unit is installed in a hot and humid place, if the humidity inside the installation space exceeds 86°F and RH 80%, it is recommended to insulate the cabinet exterior. Use glass wool or polyethylene foam as insulation; the thickness should be more than 2 in. and it must fit inside the installation space opening.

Condensation may come from the surface of the insulation. Be sure to use insulation that is designed for use with HVAC Systems. Condensation may be produced on surface during cooling operation. It is also recommended to use auxiliary drain pan and secure the unit firmly to prevent it from falling. See Figure 3 to Figure 6.

EHK knockout must be free of insulation so power can still be toggled to unit. Panels need to be removable for access to interior of the unit.



Refer to local code requirements for usage of auxiliary drain pans.

**WARNING**

**Fire hazard!**

These instructions are exclusively intended for qualified contractors and authorized installers. Work on the refrigerant circuit with flammable refrigerant in safety group A2L may only be carried out by authorized heating contractors. These heating contractors must be trained in accordance with UL 60335-2-40, Annex HH. The certificate of competence from an industry accredited body is required. Work on electrical equipment may only be carried out by a qualified electrician. Before initial commissioning, all safety related points must be checked by the particular certified heating contractors. The system must be commissioned by the system installer or a qualified person authorized by the installer. For installation of the indoor unit, refer to the corresponding installation and operation manual. If an indoor unit is installed in an unventilated area, the area shall be so constructed that should any refrigerant leak, it will not stagnate so as to create a fire or explosion hazard. The appliance shall be stored so as to prevent mechanical damage from occurring. Do not stack combustible materials on the surface of the indoor unit.

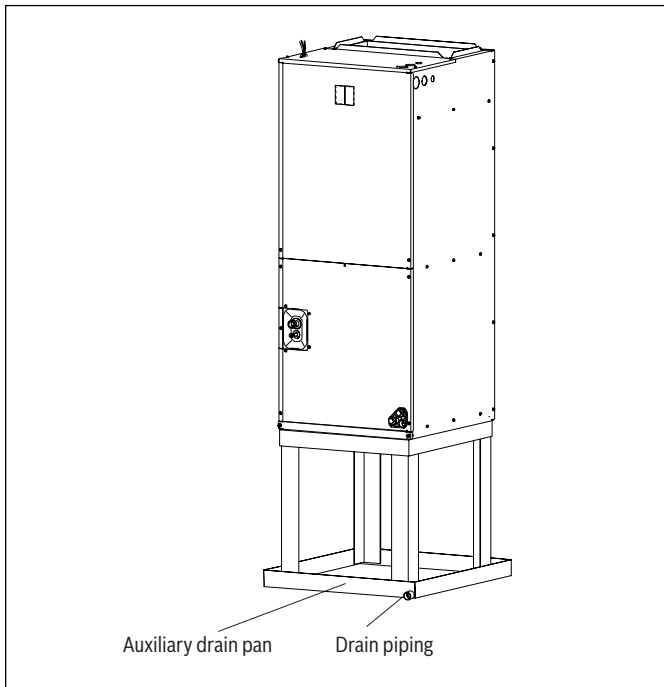

Figure 3 Installed vertical upflow

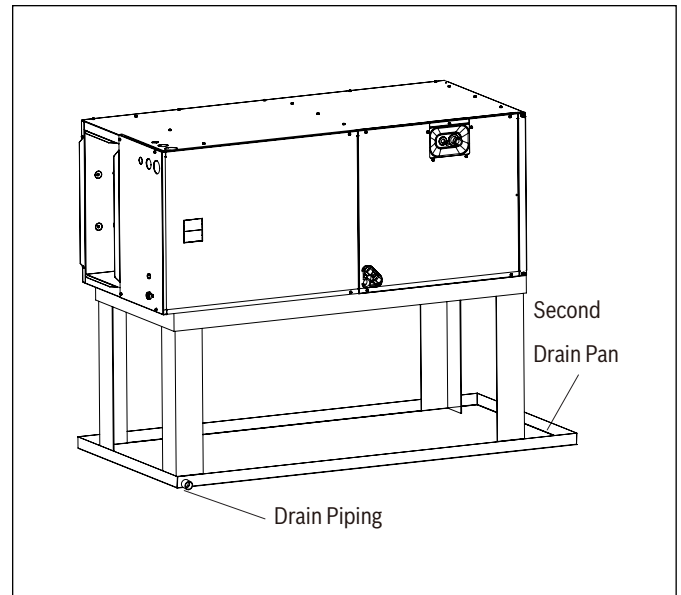

Figure 5 Installed horizontal left

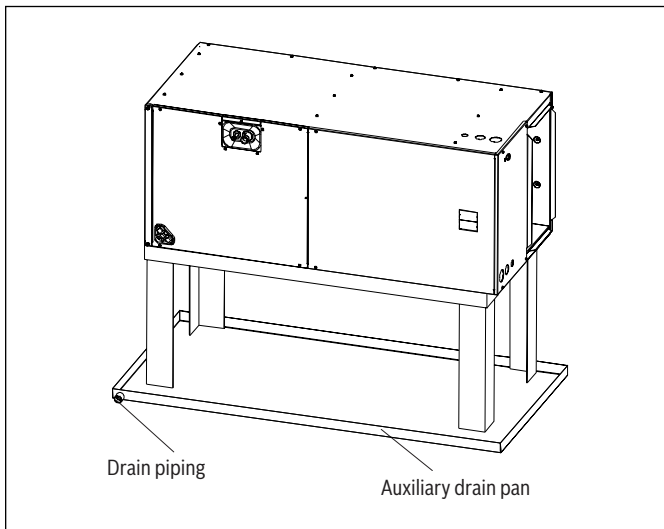

Figure 4 Installed horizontal right

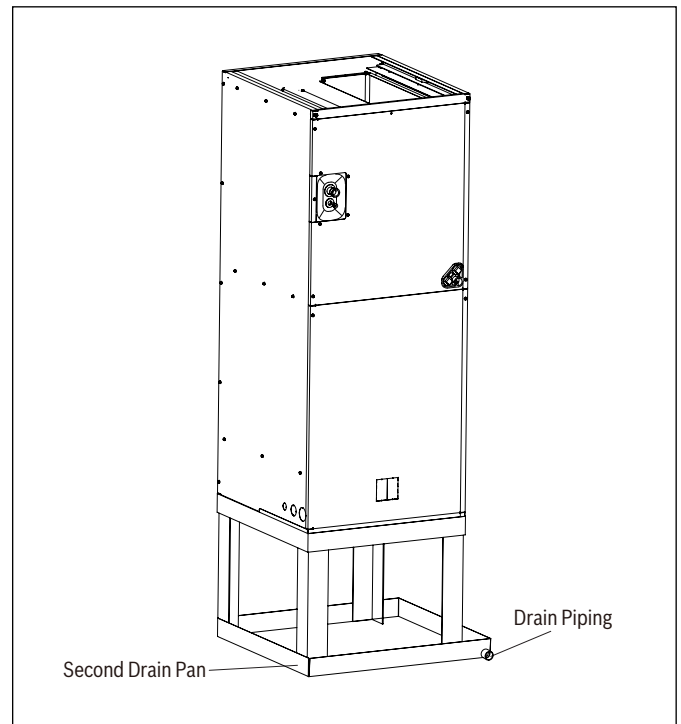

Figure 6 Installed vertical downflow

**NOTICE**

**Product damage!**

Inner extra drain pan is recommended to be installed for 4 and 5 ton vertical downflow applications installed in high humidity environments. This inner extra drain pan can be ordered using part number 8733953539 for 4,5 ton cabinets Refer to Figure 6.

**NOTICE**

**Product damage!**

For high humidity installations which include electric heat strips, it is recommended to install spacing brackets (available as a spare part from the manufacturer) between the heater and the heater collar to prevent condensation from forming on the collar.

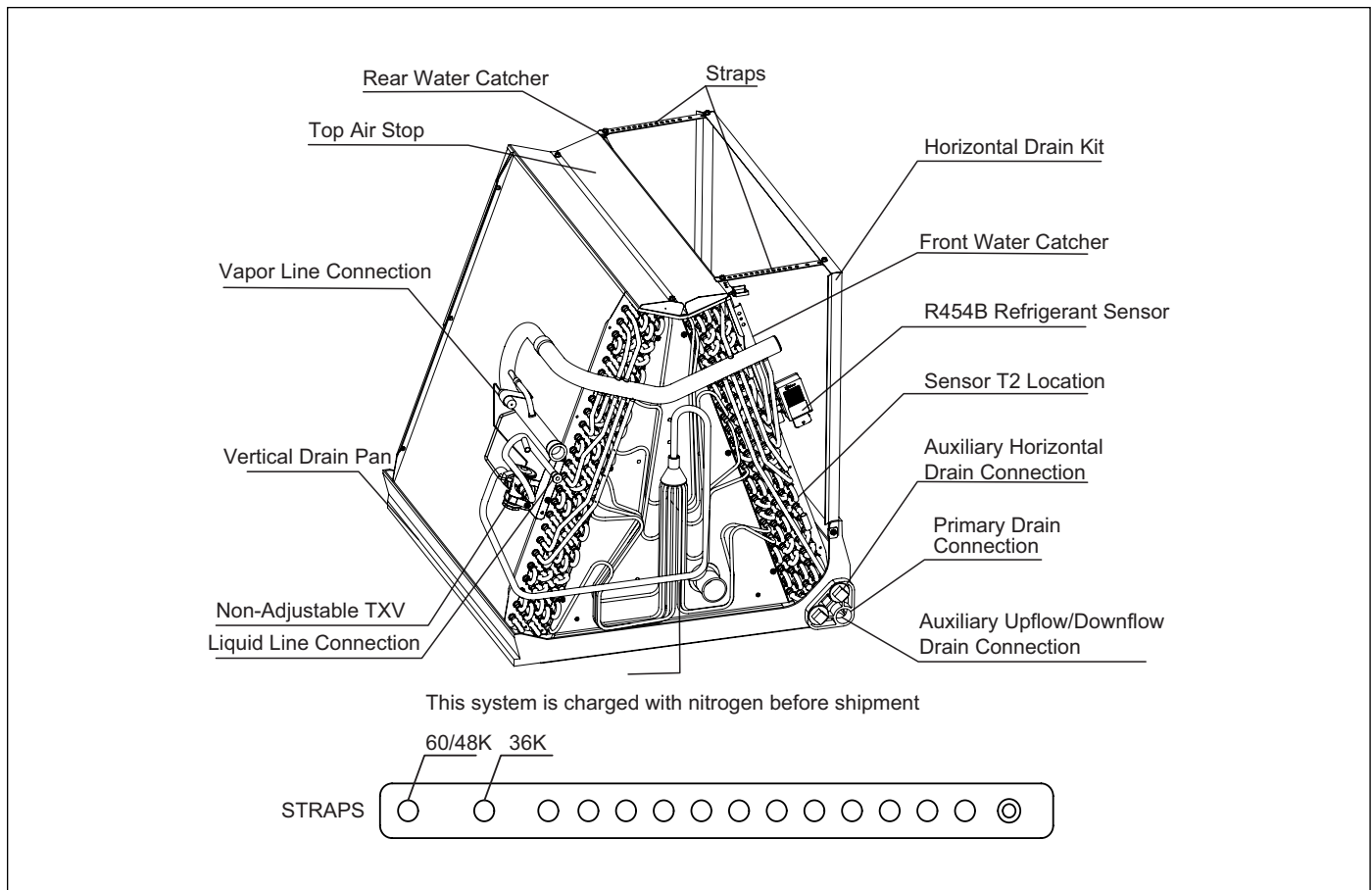

Figure 7 Indoor coil and drain pan set-up

**2.2 Unit Dimensions**

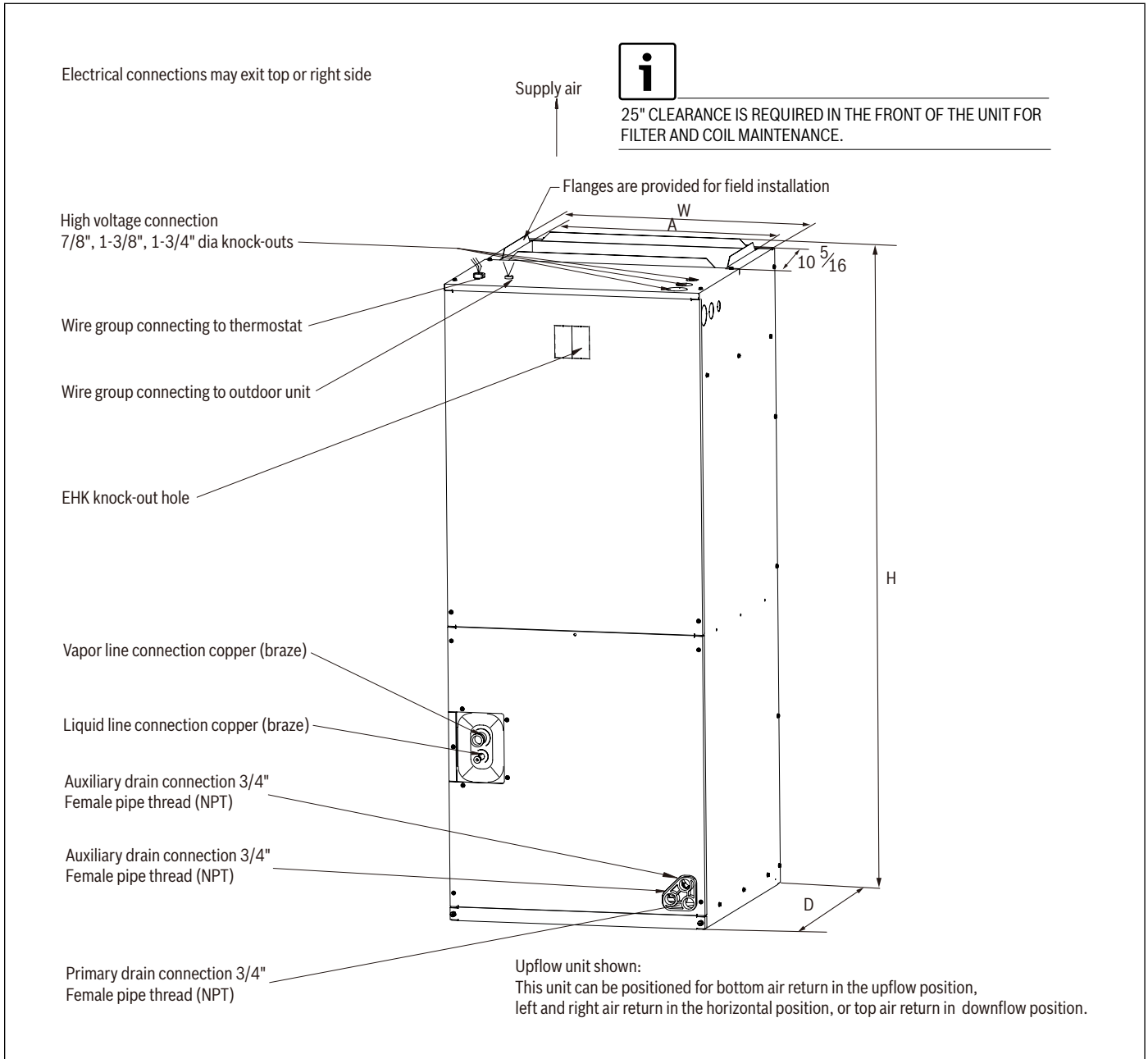

Figure 8

Model Size	Dimensions Inch [mm]				
	Unit Height "H"	Unit Width "W"	Unit Length "D"	Supply Duct "A"	Liquid Line   Vapor Line
36	46-1/2 [1180]	19-5/8 [500]	21-5/8 [550]	18 [456]	3/8   3/4 [9.5]   [19]
48	54-1/2 [1385]	22 [560]	24 [610]	19-1/2 [496]	3/8   7/8 [9.5]   [22]
60	54-1/2 [1385]	22 [560]	24 [610]	19-1/2 [496]	3/8   7/8 [9.5]   [22]

Table 2

## 2.3 Components

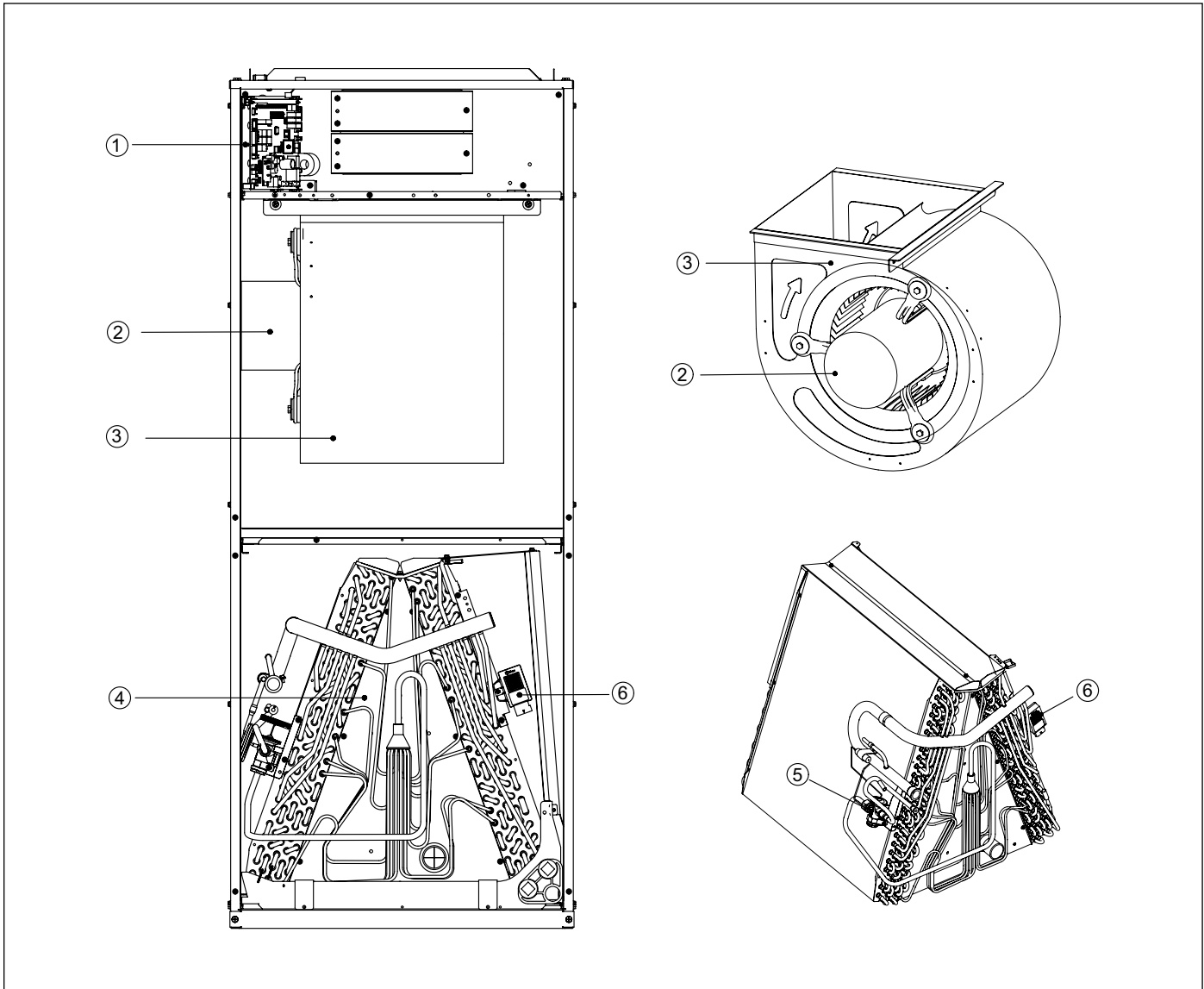

Figure 9

### COMPONENT IDENTIFICATION:

1. Main Control Board
2. Motor
3. Blower Housing
4. All Aluminum Coil
5. R-454B-TXV
6. A2L Refrigerant Sensor

## 2.4 A2L Refrigerant Sensor

R-454B refrigerant leakage sensor is configured for the indoor unit: To meet different installation scenarios, the refrigerant sensor has two installation positions. Before installing the indoor unit, check whether the refrigerant sensor is correctly installed according to Section "3 Applications" on page 16.



### **CAUTION**

#### **Fire hazard!**

Only the factory supplied or specified refrigerant leakage sensor model in the manual shall be used.

The R-454B refrigerant leakage sensor must be used to activate the refrigerant shut-off device, the alarm device, incorporated circulation airflow or other emergency controls, which shall give an electrical signal at a predetermined alarm setpoint in response to leaked refrigerant.

The location of leakage sensors shall be chosen in relation to the different installation scenarios. Please refer to the indoor unit installation manual for specific requirements.

The installation of the refrigerant leakage sensor shall allow access for checking, repair or replacement by an authorized person.

The refrigerant leakage sensor shall be installed so its function can be verified easily.

The refrigerant leakage sensor shall be protected to prevent tampering or unauthorized resetting of the pre-set value.

To be effective, the refrigerant leakage sensor must be electrically powered at all times after installation, other than when servicing.

If the refrigerant leakage sensor detects a refrigerant leak, the fan will be turned on to the maximum, the compressor will stop running. You should immediately leave the leak area and notify a professional for handling.

The service life of the refrigerant sensor is 15 years, and it should be replaced after the service life.

---



### **WARNING**

#### **Fire, explosion, personal injury!**

LEAK DETECTION SYSTEM installed on indoor unit. Unit must be powered except for service.

---

### **NOTICE**

#### **Product damage!**

R-454B refrigerant leakage sensor is configured for the indoor unit. The operation of fan can be initiated by the R-454B refrigerant sensor, which meets the incorporated circulation airflow requirements.

The allowed maximum refrigerant charge (M<sub>max</sub>) and the required minimum room area (A<sub>min</sub>) can be determined according to Table 5 to Table 9.

---

### 3 Applications

#### 3.1 Vertical Upflow

- Vertical Upflow configuration is the factory default on all models (see Figure 3).
- If return air is to be ducted, install duct flush with floor. Use fireproof resilient gasket 1/8 to 1/4 in. thick between the ducts, unit and floor. Set unit on floor over opening.



Torque applied to drain connections should not exceed 15 ft.lbs. For vertical upflow and horizontal right installations, dimensions for refrigerant and drain pipes may be found in Figure 10.

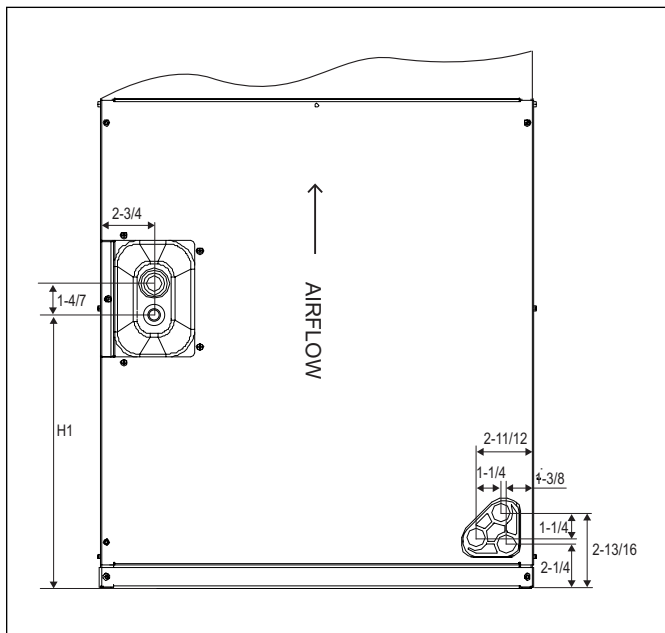

Figure 10 Dimensions For Air Handler (Coil Section)

Model Size	"H1" - in [mm]
36	13-1/5 [335.5]
48/60	13-7/8 [352.8]

Table 3

#### 3.2 Vertical Downflow

##### Conversion to Vertical Downflow:

A vertical upflow unit may be converted to vertical downflow. Remove the coil access panel, refrigerant leak sensor, and indoor coil and reinstall 180° from original position. See Figure 11.

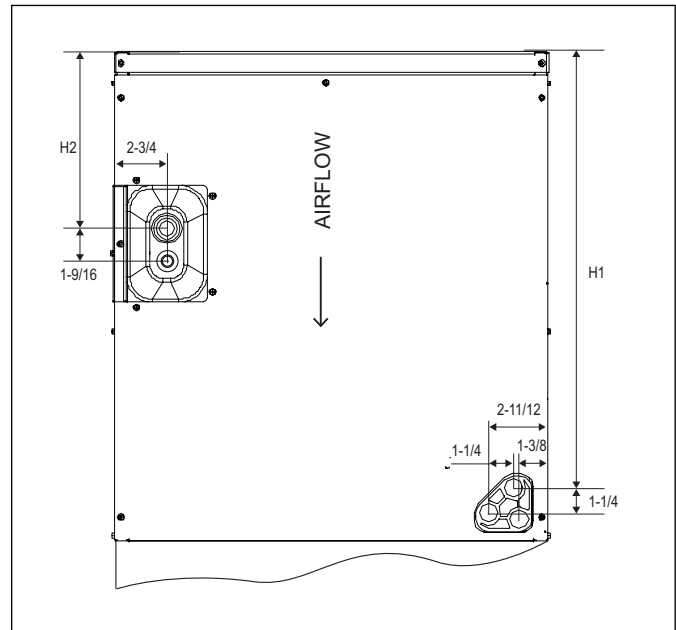

Figure 11 Dimensions for air handler (coil section)

Model Size	"H1" - in [mm]	"H2" - in [mm]
36	17-2/5 [441.5]	6-2/5 [162.5]
48/60	22-1/6 [563.5]	10-1/2 [267.2]

Table 4

#### 3.3 Horizontal

Horizontal right is the default factory configuration for all models.

##### Conversion to Horizontal Left:

A vertical upflow unit may be converted to horizontal left by removing indoor coil assembly and the refrigerant leak detection sensor. Reinstall the indoor coil and the refrigerant sensor for left hand air supply. See Figure 12.

- Rotate the unit 90° into the horizontal left position, with the coil compartment on the right and the blower compartment on the left.
- Remove the coil access panel
- Remove the refrigerant leak detection sensor and indoor coil
- Reinstall the indoor coil 180° from original position. Ensure the retaining channel is fully engaged with the coil rail. See Figure 12 and Figure 13.
- An additional field supplied drain pan kit is recommended when the unit is configured for the horizontal position over a finished ceiling and/or living space.

**Steps for Changing Cabinet Orientation to Vertical Downflow OR Horizontal Left Orientation**

1. Remove the screws and zipties securing the refrigerant, T1, and T2 sensors. Cut the zip tie holding wire loop in step 1A and remove the wire loop and T1 sensors from the bottom of the evaporator.
2. Remove the A2L refrigerant sensor from the coil and reconnect it to the side of cabinet as shown in step 2. (Figure 12, Step 2).
3. Thread the T1 and T2 sensors through the wire loop as shown in Figure 12 step 2A. Reattach refrigerant, T1, and T2 sensors to the proper location as shown in Figure 12, step 3 using field supplied zip ties to ensure that they can not move around. Ensure that the wire loop is tightened.

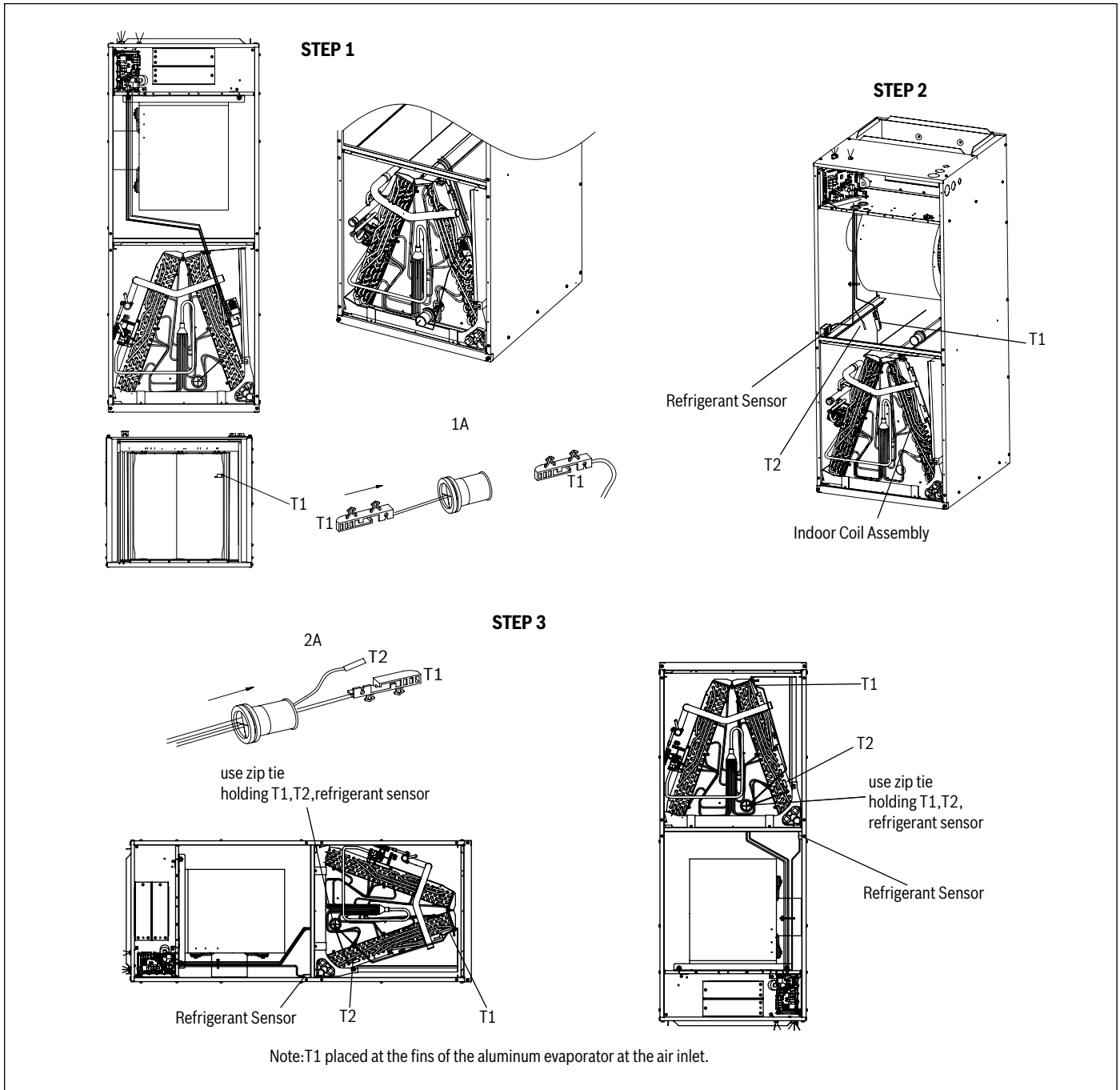

Figure 12 Vertical downflow & horizontal left applications conversion

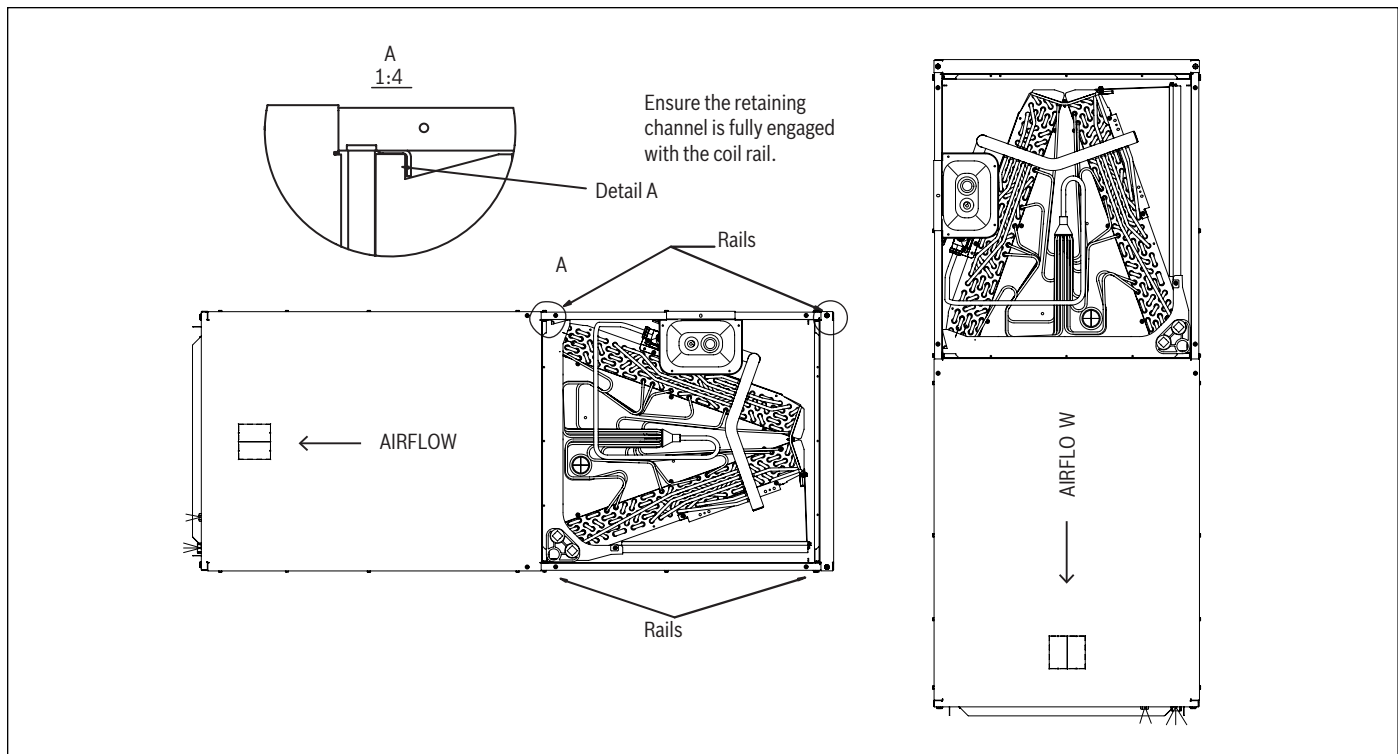

Figure 13 Vertical downflow & horizontal left applications

#### NOTICE

##### Product damage!

Horizontal units must be configured for right hand air supply or left hand air supply. Horizontal drain pan must be located under indoor coil. Failure to use the drain pan can result in property damage.

#### Conversion in Horizontal Direction:

Horizontal right-hand supply can be changed to horizontal left-hand supply by removing the indoor coil and reinstalling 180° from original.

### 3.4 Installation in an Unconditioned Space

#### NOTICE

##### Product damage!

There are two pairs of coil rails in the air handler for upflow and downflow application. If the air handler is installed in an unconditioned space, the two unused coil rails should be removed to minimize air handler surface sweating. The coil rails can be easily removed by unscrewing the 6 mounting screws from both sides of the cabinet.

### 3.5 Refrigerant Charge and Room Area Limitations

In UL/CSA 60335-2-40, R-454B refrigerant is classified as class A2L, which is mildly flammable. Therefore, R-454B refrigerant is suitable for systems needing additional refrigerant charge and which will limit the area of the rooms being served by the system.

Similarly, the total amount of refrigerant in the system shall be less than or equal to the allowable maximum refrigerant charge. The allowable maximum refrigerant charge depends on the area of the rooms being served by the system.

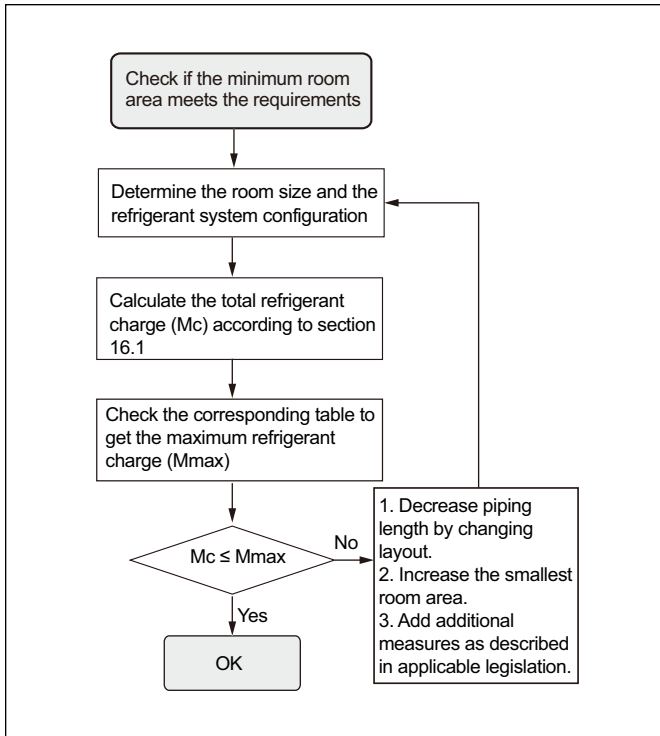

Figure 14



The terms in this section are explained as follows:

- $M_c$ : The actual refrigerant charge in the system.
- $A$ : the actual room area where the appliance is installed.
- $A_{min}$ : The required minimum room area.
- $M_{max}$ : The allowable maximum refrigerant charge in a room.
- $Q_{min}$ : The minimum circulation airflow.
- $A_{nvmmin}$ : The minimum opening area for connected rooms.
- $T_{Amin}$ : The total area of the conditioned space (For appliances serving one or more rooms with an air duct system).
- $T_A$ : The total area of the conditioned space connected by air ducts.

#### 3.5.1 The Room Area Calculation Requirements



##### Flammable refrigerant!

The space considered shall be any space which contains refrigerant-containing parts or into which refrigerant could be released.

The room area ( $A$ ) of the smallest, enclosed, occupied space shall be used in the determination of the refrigerant quantity limits.

For determination of room area ( $A$ ) when used to calculate the refrigerant charge limit, the following shall apply.

The room area ( $A$ ) shall be defined as the room area enclosed by the projection to the base of the walls, partitions and doors of the space in which the appliance is installed.

Spaces connected by only drop ceilings, ductwork, or similar connections shall not be considered a single space.

Units mounted higher than 70-55/64 inches and spaces divided by partition walls that are no higher than 62-63/64 inches shall be considered a single space. Rooms on the same floor and connected by an open passageway between the spaces can be considered a single room when determining compliance to  $A_{min}$ , if the passageway complies with all of the following.

1. It is a permanent opening.
2. It extends to the floor.
3. It is intended for people to walk through.

The area of the connected rooms, on the same floor, connected by permanent opening in the walls and/or doors between occupied spaces, including gaps between the wall and the floor, can be considered a single room when determining compliance to  $A_{min}$ , provided all of the following conditions are met as Figure 15.

##### Low level opening:

1. The opening shall not be less than  $A_{nvmmin}$  in Table 4.
2. The area of any openings above 11-13/16 inches from the floor shall not be considered in determining compliance with  $A_{nvmmin}$ .
3. At least 50% of the opening area of  $A_{nvmmin}$  shall be below 7-7/8 inches from the floor.
4. The bottom of the opening is not more than 3-15/16 inches from the floor.
5. The opening is a permanent opening that cannot be closed.
6. For openings extending to the floor the height shall not be less than 25/32 inches above the surface of the floor covering.

##### High level opening:

1. The opening shall not be less than 50% of  $A_{nvmmin}$  in Table 4.
2. The opening is a permanent opening that cannot be closed.
3. The opening shall be at least 59 inches above the floor.
4. The height of the opening is not less than 25/32 inches.

##### Room size requirement:

1. The room into which refrigerant can leak, plus the connected adjacent room(s) shall have a total area not less than  $A_{min}$ .  $A_{min}$  is shown in Table 6 to Table 8.
2. The room area in which the unit is installed shall be not less than 20%  $A_{min}$ .  $A_{min}$  is shown in Table 6 to Table 8.



The requirement for the second opening can be met by drop ceilings, ventilation ducts, or similar arrangements that provide an airflow path between the connected rooms.

The minimum opening for natural ventilation ( $Anv_{min}$ ) in connected rooms is related to the room area ( $A$ ), the actual refrigerant charge of refrigerant in the system ( $M_c$ ), and the allowable MAXIMUM REFRIGERANT CHARGE in the system ( $M_{max}$ ),  $Anv_{min}$  can be determined according to Table 4.

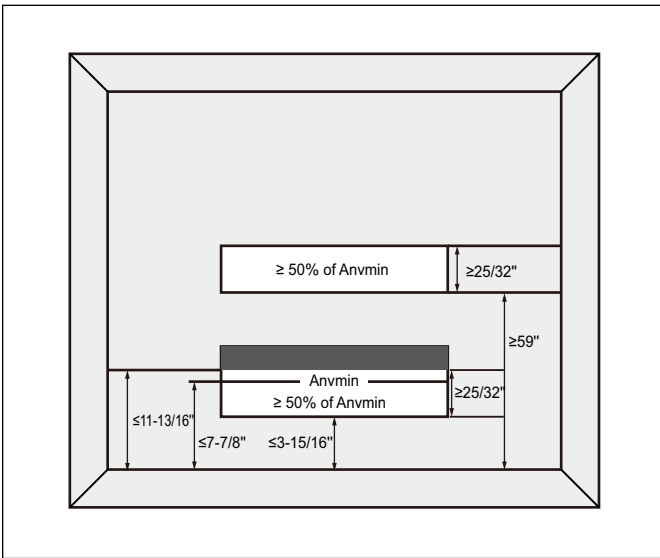

Figure 15

The minimum opening area for connected rooms:

A		$m_c$		$m_{max}$		$Anv_{min}$	
ft <sup>2</sup>	m <sup>2</sup>	lb-oz	kg	lb-oz	kg	ft <sup>2</sup>	m <sup>2</sup>
100	9.2	15-8	7	3-6	1.5	2.0	0.19
120	11.1	15-8	7	4-1	1.8	1.8	0.18
140	13.0	15-8	7	4-11	2.1	1.7	0.17
160	14.8	15-8	7	5-6	2.4	1.6	0.16
180	16.7	15-8	7	6-1	2.7	1.5	0.15
200	18.5	15-8	7	6-12	3.0	1.4	0.14
220	20.4	15-8	7	7-7	3.3	1.3	0.13
240	22.2	15-8	7	8-2	3.6	1.2	0.12
260	24.1	15-8	7	8-13	3.9	1.1	0.11
280	26.0	15-8	7	9-7	4.3	0.9	0.10
300	27.8	15-8	7	10-2	4.6	0.8	0.09
320	29.7	15-8	7	10-13	4.9	0.7	0.08
340	31.5	15-8	7	11-8	5.2	0.6	0.07
360	33.4	15-8	7	12-3	5.5	0.5	0.05
380	35.3	15-8	7	12-14	5.8	0.4	0.04
400	37.1	15-8	7	13-9	6.1	0.3	0.03
420	39.0	15-8	7	14-3	6.4	0.1	0.02
440	40.8	15-8	7	14-14	6.7	0.0	0.01
460	42.7	15-8	7	15-9	7.0	0.0	0.00

Table 5

Note: Take the  $M_c=15lb$  8oz as an example.

For appliances serving one or more rooms with an air duct system, The room area calculation shall be determined based on the total area of the conditioned space (TA) connected by ducts taking into consideration that the circulating airflow distributed to all the rooms by the appliance integral indoor fan will mix and dilute the leaking refrigerant before entering any room.

### 3.5.2 The Allowed Maximum Refrigerant Charge and Required Minimum Room Area

If the fan incorporated to an appliance is continuously operated or operation is initiated by a REFRIGERANT DETECTION SYSTEM with a sufficient CIRCULATION AIRFLOW rate, the allowable maximum refrigerant charge ( $M_{max}$ ) and the required minimum room area ( $A_{min}/TA_{min}$ ) is shown in Table 5 and Table 6 to Table 8.

The allowable maximum refrigerant charges:

A/TA		$m_{max}$		A/TA		$m_{max}$	
ft <sup>2</sup>	m <sup>2</sup>	lb-oz	kg	ft <sup>2</sup>	m <sup>2</sup>	lb-oz	kg
30	2.8	0-14	0.4	250	23.2	8-6	3.8
40	3.7	1-5	0.6	260	24.2	8-9	3.9
50	4.6	1-9	0.7	270	25.1	9-0	4.1
60	5.6	1-16	0.9	280	26.0	9-7	4.3
70	6.5	2-3	1	290	26.9	9-11	4.4
80	7.4	2-10	1.2	300	27.9	10-2	4.6
90	8.4	2-14	1.3	310	28.8	10-5	4.7
100	9.3	3-5	1.5	320	29.7	10-12	4.9
110	10.2	3-8	1.6	330	30.7	11-0	5.0
120	11.1	3-15	1.8	340	31.6	11-7	5.2
130	12.1	4-3	1.9	350	32.5	11-10	5.3
140	13.0	4-10	2.1	360	33.4	12-2	5.5
150	13.9	5-1	2.3	370	34.4	12-5	5.6
160	14.9	5-5	2.4	380	35.3	12-12	5.8
170	15.8	5-12	2.6	390	36.2	13-0	5.9
180	16.7	5-15	2.7	400	37.2	13-7	6.1
190	17.7	6-6	2.9	410	38.1	13-14	6.3
200	18.6	6-10	3.0	420	39.0	14-1	6.4
210	19.5	7-1	3.2	430	39.9	14-8	6.6
220	20.4	7-4	3.3	440	40.9	14-12	6.7
230	21.4	7-11	3.5	450	41.8	15-3	6.9
240	22.3	7-15	3.6	460	42.7	15-6	7.0

Table 6

The required minimum room area:

$m_c$		$A_{min}/TA_{min}$		$m_c$		$A_{min}/TA_{min}$	
lb-oz	kg	ft <sup>2</sup>	m <sup>2</sup>	lb-oz	kg	ft <sup>2</sup>	m <sup>2</sup>
2-2	1.0	65.1	6.1	10-2	4.6	299.1	27.8
2-9	1.2	78.1	7.3	10-9	4.8	312.1	29.0
3-0	1.4	91.1	8.5	11-0	5.0	325.1	30.3
3-7	1.6	104.1	9.7	11-7	5.2	338.2	31.5
3-15	1.8	117.1	10.9	11-14	5.4	351.2	32.7
4-6	2.0	130.1	12.1	12-5	5.6	364.2	33.9
4-13	2.2	143.1	13.3	12-12	5.8	377.2	35.1
5-4	2.4	156.1	14.5	13-3	6.0	390.2	36.3
5-11	2.6	169.1	15.8	13-10	6.2	403.2	37.5
6-2	2.8	182.1	17.0	14-1	6.4	416.2	38.7
6-9	3.0	195.1	18.2	14-8	6.6	429.2	39.9
7-0	3.2	208.1	19.4	14-15	6.8	442.2	41.1
7-7	3.4	221.1	20.6	15-6	7.0	455.2	42.3
7-15	3.6	234.1	21.8	15-14	7.2	468.2	43.5
8-6	3.8	247.1	23.0	16-5	7.4	481.2	44.7
8-13	4.0	260.1	24.2	16-12	7.6	494.2	46.0
9-4	4.2	273.1	25.4	17-3	7.8	507.2	47.2
9-11	4.4	286	26.6				

Table 7

The required minimum room area if installed at an altitude over 2000ft:

Altitude [m]		601-800		801-1000		1001-1200		1201-1400		1401-1600		1601-1800		1801-2000	
Altitude [ft]		1970-2625		2626-3280		3281-3938		3940-4593		4596-5250		5251-5905		5908-6562	
$m_c$		$A_{min}/TA_{min}$													
lb-oz	kg	ft <sup>2</sup>	m <sup>2</sup>	ft <sup>2</sup>	m <sup>2</sup>	ft <sup>2</sup>	m <sup>2</sup>	ft <sup>2</sup>	m <sup>2</sup>	ft <sup>2</sup>	m <sup>2</sup>	ft <sup>2</sup>	m <sup>2</sup>	ft <sup>2</sup>	m <sup>2</sup>
2	0.9	60.2	5.6	62.0	5.8	63.2	5.9	64.9	6.1	66.1	6.2	67.9	6.4	69.7	6.5
3	1.4	90.3	8.4	93.0	8.7	94.7	8.8	97.4	9.1	99.1	9.3	101.8	9.5	104.5	9.7
4	1.8	120.4	11.2	123.9	11.6	126.3	11.8	129.8	12.1	132.2	12.3	135.7	12.7	139.3	13.0
5	2.3	150.5	14.0	154.9	14.4	157.8	14.7	162.3	15.1	165.2	15.4	169.6	15.8	174.1	16.2
6	2.7	180.5	16.8	185.9	17.3	189.4	17.6	194.7	18.1	198.2	18.5	203.5	19.0	208.9	19.4
7	3.2	210.6	19.6	216.8	20.2	220.9	20.6	227.1	21.1	231.3	21.5	237.5	22.1	243.7	22.7
8	3.6	240.7	22.4	247.8	23.1	252.5	23.5	259.6	24.2	264.3	24.6	271.4	25.3	278.5	25.9
9	4.1	270.8	25.2	278.8	25.9	284.1	26.4	292.0	27.2	297.3	27.7	305.3	28.4	313.3	29.1
10	4.5	300.9	28.0	309.7	28.8	315.6	29.4	324.5	30.2	330.4	30.7	339.2	31.6	348.1	32.4
11	5.0	331.0	30.8	340.7	31.7	347.2	32.3	356.9	33.2	363.4	33.8	373.1	34.7	382.9	35.6
12	5.4	361.0	33.6	371.7	34.6	378.7	35.2	389.3	36.2	396.4	36.9	407.0	37.9	417.7	38.8
13	5.9	391.1	36.4	402.6	37.4	410.3	38.2	421.8	39.2	429.5	39.9	441.0	41.0	452.5	42.1
14	6.4	421.2	39.2	433.6	40.3	441.8	41.1	454.2	42.2	462.5	43.0	474.9	44.2	487.3	45.3
15	6.8	451.3	42.0	464.6	43.2	473.4	44.0	486.7	45.3	495.5	46.1	508.8	47.3	522.1	48.5
16	7.3	481.4	44.8	495.5	46.1	505.0	47.0	519.1	48.3	528.5	49.1	542.7	50.5	556.9	51.8
17	7.7	511.4	47.6	526.5	49.0	536.5	49.9	551.6	51.3	561.6	52.2	576.6	53.6	591.7	55.0
18	8.2	541.5	50.4	557.5	51.8	568.1	52.8	584.0	54.3	594.6	55.3	610.5	56.8	626.5	58.2
19	8.6	571.6	53.1	588.4	54.7	599.6	55.8	616.4	57.3	627.6	58.4	644.5	59.9	661.3	61.5
20	9.1	601.7	55.9	619.4	57.6	631.2	58.7	648.9	60.3	660.7	61.4	678.4	63.1	696.1	64.7

Table 8

Altitude [m]		2001-2200		2201-2400		2401-2600		2601-2800		2801-3000		3001-3200		above 3200	
Altitude [ft]		6565-7218		7221-7874		7877-8530		8533-9186		9190-9843		9846-10500		above 10500	
$m_c$		$A_{min}/TA_{min}$													
lb-oz	kg	ft <sup>2</sup>	m <sup>2</sup>	ft <sup>2</sup>	m <sup>2</sup>	ft <sup>2</sup>	m <sup>2</sup>	ft <sup>2</sup>	m <sup>2</sup>	ft <sup>2</sup>	m <sup>2</sup>	ft <sup>2</sup>	m <sup>2</sup>	ft <sup>2</sup>	m <sup>2</sup>
2	0.9	71.4	6.7	73.8	6.9	75.5	7.1	77.9	7.3	80.3	7.5	82.6	7.7	82.6	7.7
3	1.4	107.1	10.0	110.6	10.3	113.3	10.6	116.8	10.9	120.4	11.2	123.9	11.6	123.9	11.6
4	1.8	142.8	13.3	147.5	13.7	151.0	14.1	155.8	14.5	160.5	15.0	165.2	15.4	165.2	15.4
5	2.3	178.5	16.6	184.4	17.2	188.8	17.6	194.7	18.1	200.6	18.7	206.5	19.2	206.5	19.2
6	2.7	214.2	19.9	221.2	20.6	226.5	21.1	233.6	21.8	240.7	22.4	247.8	23.1	247.8	23.1
7	3.2	249.8	23.3	258.1	24.0	264.3	24.6	272.6	25.4	280.8	26.1	289.1	26.9	289.1	26.9
8	3.6	285.5	26.6	295.0	27.4	302.0	28.1	311.5	29.0	320.9	29.9	330.4	30.7	330.4	30.7
9	4.1	321.2	29.9	331.8	30.9	339.8	31.6	350.4	32.6	361.0	33.6	371.7	34.6	371.7	34.6
10	4.5	356.9	33.2	368.7	34.3	377.5	35.1	389.3	36.2	401.1	37.3	412.9	38.4	412.9	38.4
11	5.0	392.6	36.5	405.6	37.7	415.3	38.6	428.3	39.8	441.3	41.0	454.2	42.2	454.2	42.2
12	5.4	428.3	39.8	442.4	41.1	453.0	42.1	467.2	43.5	481.4	44.8	495.5	46.1	495.5	46.1
13	5.9	464.0	43.1	479.3	44.6	490.8	45.6	506.1	47.1	521.5	48.5	536.8	49.9	536.8	49.9
14	6.4	499.6	46.5	516.2	48.0	528.5	49.1	545.1	50.7	561.6	52.2	578.1	53.8	578.1	53.8
15	6.8	535.3	49.8	553.0	51.4	566.3	52.7	584.0	54.3	601.7	55.9	619.4	57.6	619.4	57.6
16	7.3	571.0	53.1	589.9	54.8	604.0	56.2	622.9	57.9	641.8	59.7	660.7	61.4	660.7	61.4
17	7.7	606.7	56.4	626.8	58.3	641.8	59.7	661.9	61.5	681.9	63.4	702.0	65.3	702.0	65.3
18	8.2	642.4	59.7	663.6	61.7	679.5	63.2	700.8	65.2	722.0	67.1	743.3	69.1	743.3	69.1
19	8.6	678.1	63.0	700.5	65.1	717.3	66.7	739.7	68.8	762.1	70.8	784.5	72.9	784.5	72.9
20	9.1	713.8	66.4	737.4	68.5	755.0	70.2	778.6	72.4	802.2	74.6	825.8	76.8	825.8	76.8

Table 9

The minimum circulation airflow:

$m_c$		$Q_{min}$		$m_c$		$Q_{min}$	
lb-oz	kg	CFM	m <sup>3</sup> /h	lb-oz	kg	CFM	m <sup>3</sup> /h
2-2	1.0	118	200	10-2	4.6	540	917
2-9	1.2	141	240	10-9	4.8	564	957
3-0	1.4	165	280	11-0	5.0	587	997
3-7	1.6	188	319	11-7	5.2	611	1037
3-15	1.8	212	359	11-14	5.4	634	1077
4-6	2.0	235	399	12-5	5.6	658	1117
4-13	2.2	259	439	12-12	5.8	681	1157
5-4	2.4	282	479	13-3	6.0	704	1197
5-11	2.6	306	519	13-10	6.2	728	1236
6-2	2.8	329	559	14-1	6.4	751	1276
6-9	3.0	352	599	14-8	6.6	775	1316
7-0	3.2	376	638	14-15	6.8	798	1356
7-7	3.4	399	678	15-6	7.0	822	1396
7-15	3.6	423	718	15-14	7.2	845	1436
8-6	3.8	446	758	16-5	7.4	869	1476
8-13	4.0	470	798	16-12	7.6	892	1515
9-4	4.2	493	838	17-3	7.8	916	1555
9-11	4.4	517	878				

Table 10



### CAUTION

#### Min. room area and airflow required!

If the actual room area, air outlet height, and refrigerant charge amount are not reflected in the above table, the most severe cases need to be considered according to the data in Table 4 to Table 9.



### CAUTION

#### Min. room area and airflow required!

The allowable maximum refrigerant charge in Table 5 or the required minimum room area in Table 6 to Table 8 is available only if the following conditions are met:

Minimum velocity of 3.28ft/s, which is calculated as the indoor unit airflow divided by the nominal face area of the outlet. And the grill area shall not be deducted.

Minimum airflow rate must meet the corresponding values in Table 9, which is related to the actual refrigerant charge of the system ( $M_c$ ).

R-454B refrigerant leakage sensor is installed.



The maximum refrigerant limit described above applies to unventilated areas. If adding additional measures, such as areas with mechanical ventilation or natural ventilation, The maximum refrigerant charge can be increased or the minimum room area can be reduced.

R-454B refrigerant leakage sensor is designed for the indoor unit, meets the incorporated circulation airflow requirements, the maximum refrigerant charge or minimum room area can be determined according to Table 5 or Table 6 to Table 8.

## 4 Electrical Wiring

Field wiring must comply with the National Electric Code (C.E.C. in Canada) and any applicable local ordinances.

### **WARNING**

#### **Electrical shock!**

Disconnect all power to unit before installing or servicing. More than one disconnect switch may be required to deenergize the equipment. Hazardous voltage can cause severe personal injury or death.

### 4.1 Power Wiring

It is important that proper electrical power is available for connection to the unit being installed. See the unit nameplate, wiring diagram, and electrical data in the installation instructions for more detailed requirements.

- If required, install a branch circuit disconnect of adequate size, located within sight, and readily accessible from the unit.

### **WARNING**

#### **Electrical shock!**

The breaker inside the air handler unit cannot serve as circuit protection and cannot be operated by users. Maintenance personnel must disconnect the main power supply before servicing the unit.



When the Electric Heater is installed, units may be equipped with one or two 30-60 amp. circuit breakers. These breaker(s) protect the internal wiring in the event of a short circuit and serve as a disconnect. Circuit breakers installed within the unit do not provide over-current protection of the supply wiring and therefore may be sized larger than the branch circuit protection.

- Supply circuit power wiring must be 167 °F [75 °C] minimum copper conductors only. See Electrical Data In this section for ampacity, wire size and circuit protector requirements. Supply circuit protection devices may be either fuses or "HACR" type circuit breakers.
- High voltage wiring may be run through knockout holes on the right, left or top of the unit.
- Three 7/8", 1-3/8", 1-3/4" dia. concentric knockouts are provided for running high voltage wiring to the unit.
- High voltage wiring must be connected to the red and black wiring in the control section of the air handler.
- Ensure supply voltage to the unit is not more than 10% over / under rated voltage
- Power wiring is connected to the power terminal block in unit electric cabinet

## 4.2 Control Wiring

**NOTICE**

**Product damage!**

Do not connect the communication cables with power on, otherwise it will damage the circuit board.

Do not connect the power cables (high voltage) to the Hyper-Link (M1 M2) communication wires (low voltage), otherwise it will damage the circuit board.

Do not interconnect different communication buses (M1, M2, C, B, Y, W, etc.), otherwise it will damage the circuit board.

Do not squeeze or pull the unit connection, and make sure the wiring is not in contact with the sharp edges of the sheet metal.

Make sure, after installation, separation of control wiring and power wiring has been maintained.



**WARNING**

**Electrical shock!**

Low voltage control connections are made to low voltage pigtailed extending from top of air handler. The **Hyper-Link(M1 M2) communication wires** are pre-installed on the main control board (CN9). The connectors of communication cables must be connected reliably and protected by insulation. The copper cables must not be exposed. Unused communication cables should be insulated, and the copper cables must not be exposed. Avoid sharp edges of the sheet metal for communication cables to prevent wear. If the wear is serious, it may lead to short circuit or electric leakage and cause danger. Do not pull the communication cables. The communication cables must be routed as closely as possible, and when there is strong electromagnetic interference in the environment, it is recommended to use shielded cables for communication cables. Otherwise, the communication may be abnormal. When the shielded cables are used, the shielding layers at both ends must be connected to sheet metal. Power cords and communication cables must be separated from each other with a distance of more than 2 inches to prevent interference.



Low voltage control wiring should not be run in conduit with high voltage wiring. Keep distance between the two conduits per local codes.

Hyper-Link (M1 M2) Communication Wire Size	Max Length
16/18 AWG	300 ft.

Table 11

- Maximum Low Voltage Wiring Length can be seen in Table 11.
- See wiring diagram located on inside of blower access panel of air handler for proper wiring instruction.
- After installation, ensure separation of low voltage and high voltage wiring is maintained.



Hyper-Link(M1 M2) Communication Mode is only available for specified models.

## 4.3 Grounding



**WARNING**

**Electrical shock!**

The unit must be permanently grounded. Failure to do so can result in electrical shock causing personal injury or death.

- The ground may consist of electrical wire or metal conduit when installed in accordance with existing electrical codes.
- Grounding may also be accomplished by attaching ground wire(s) to ground lug provided in the unit wiring compartment.
- Use of multiple supply circuits require grounding of each circuit to lug provided in unit.
- Ground lug is located on the upper right side of the cabinet.

## 4.4 Electrical Data

Model	Voltage	Frequency [Hz]	Blower Power [hp]	Speeds	Minimum Circuit Ampacity [A]	Maximum Circuit Protector [A]
36	208/230	60	1/2	5	4.2	10
48	208/230	60	3/4	5	7.8	10
60	208/230	60	3/4	5	7.8	10

Table 12

#### 4.5 Electric Heat Kit MCA/MOP Data



When installing a EHK-XXB model, use the included cable adapter (8733983631) in the accessory bag to connect the EHK to CN6 on the control board. **DO NOT THROW AWAY AS THIS IS NEEDED FOR THE INSTALLATION.**

This adapter is not needed for the 3-stage EHK-15I and EHK-20I models.

Heat Kit Model	Heat Kit Power [kW]	Fan speed				
		1	2	3	4	5
EHK-15I	15	X	X	•	•	•
EHK-20I	20	X	X	X	•	•

Table 13 3 Stage Electric Heat Kit Fan Speed

Heat Kit Model	Stages	Heat Kit Power [kW]	Min. Circuit Ampacity		Max. Fuse or Breaker (HACR) Ampacity	
			240V	208V	240V	208V
EHK-05B	1	5	26.0	22.6	30	25
EHK-08B	1	7.5	39.4	33.9	40	35
EHK-10B	1	10	52.1	45.1	60	50
EHK-15B	2	15	52.1/26	45.1/22.6	60/30	50/25
EHK-20B	2	20	52.1/52.1	45.1/45.1	60/60	50/50
EHK-15I	3	15	79	68	80	70
EHK-20I	3	20	105	91	110	100

Table 14 Electric Heat Kit Data without Unit (Dual Point)

Heat Kit Model	Air Handler Model	Heat Kit Power [kW]	Min. Circuit Ampacity		Max. Fuse or Breaker (HACR) Ampacity		Fan speed				
			240V	208V	240V	208V	1	2	3	4	5
EHK-05B	36	5	30.2	26.8	35	30	•	•	•	•	•
EHK-08B		7.5	43.6	38.1	45	40	X	•	•	•	•
EHK-10B		10	56.3	49.3	60	50	X	X	•	•	•
EHK-15B		15	56.3/26	49.3/22.6	60/30	50/25	X	X	•	•	•
EHK-20B		20	56.3/52.1	49.3/45.1	60/60	50/50	X	X	X	•	•
EHK-05B	48	5	33.8	30.4	35	35	•	•	•	•	•
EHK-08B		7.5	47.2	41.7	50	45	•	•	•	•	•
EHK-10B		10	59.9	52.9	60	60	•	•	•	•	•
EHK-15B		15	59.9/26	52.9/22.6	60/30	60/25	X	X	•	•	•
EHK-20B		20	59.9/52.1	52.9/45.1	60/60	60/50	X	X	X	•	•
EHK-05B	60	5	33.8	30.4	35	35	X	X	•	•	•
EHK-08B		7.5	47.2	41.7	50	45	X	X	•	•	•
EHK-10B		10	59.9	52.9	60	60	X	X	•	•	•
EHK-15B		15	59.9/26	52.9/22.6	60/30	60/25	X	X	•	•	•
EHK-20B		20	59.9/52.1	52.9/45.1	60/60	60/50	X	X	X	•	•

Table 15 Suitable heat kits for AHU multi position installation (Single Point)

- Heat kit suitable for AHU 4-way position installation.
- Heat pump systems require a specified airflow. Each ton of cooling requires between 350 and 450 cubic feet of air per minute (CFM), or 400 CFM nominally.

**Heater Kit Accessories**

Model	Stages	Description	36	48	60
EHK-05B <sup>1</sup>	1	5 kW Heat Kit, Double Pole Breaker	•	•	•
EHK-08B <sup>1</sup>	1	7.5 kW Heat Kit, Double Pole Breaker	•	•	•
EHK-10B <sup>1</sup>	1	10 kW Heat Kit, Double Pole Breaker	•	•	•
EHK-15B <sup>1</sup>	2	15 kW Heat Kit, Double Pole Breaker	•	•	•
EHK-20B <sup>1</sup>	2	20 kW Heat Kit, Double Pole Breaker	•	•	•
EHK-15I	3	15 kW Heat Kit, Double Pole Breaker	•	•	•
EHK-20I	3	20 kW Heat Kit, Double Pole Breaker	•	•	•

Table 16

[ • means available, X means not available ]

<sup>1</sup> For the 1 stage and 2 stage electric heat kits, an **adapter cable (8733983631)** found in the accessory bag is **REQUIRED** to connect the heater kit to the circuit board. **DO NOT THROW AWAY.**

**WARNING**

**Electrical shock, personal injury, product damage, property damage!**

When installing an electric heat kit, always follow local electrical codes—such as the National Electrical Code (NEC) in the U.S. or the Canadian Electrical Code (CEC) in Canada—to ensure the installation is safe and compliant. Be aware that some codes may require the use of field-supplied electrical terminals.

## 5 Airflow Performance

Airflow performance data is based on cooling performance with a coil and no filter in place. Check the performance table for appropriate unit size selection.

External static pressure should stay within the minimum and maximum limits shown in the table below in order to ensure proper operation of both cooling, heating, and electric heating operation.

Air Handler Model Size	Motor Speed		CFM Wet Coil Without Filter and Electric Heat										
			External Static Pressure-Inches W.C. [kPa]										
			0	0.1	0.2	0.3	0.4	0.5	0.58	0.6	0.7	0.8	0.9
36	Tap 1	Power / W	113	120	128	135	142	148	153	155	161	168	/
		CFM	998	925	823	735	667	596	537	516	440	373	/
	Tap 2	Power / W	162	170	177	187	196	203	208	210	217	225	/
		CFM	1176	1117	1059	957	874	808	753	751	693	626	/
	Tap 3	Power / W	214	224	233	241	254	263	270	272	279	287	/
		CFM	1327	1271	1218	1165	1066	990	938	925	873	821	/
	Tap 4	Power / W	284	294	304	313	323	337	346	348	357	366	/
		CFM	1479	1430	1380	1334	1284	1186	1126	1112	1054	1005	/
	Tap 5	Power / W	353	362	372	381	390	400	413	416	427	437	/
		CFM	1586	1543	1498	1454	1411	1360	1284	1265	1197	1143	/
48	Tap 1	Power / W	211	220	230	239	247	257	268	269	279	289	298
		CFM	1424	1373	1326	1269	1221	1157	1088	1075	1010	951	893
	Tap 2	Power / W	295	307	316	325	334	342	350	352	364	380	391
		CFM	1605	1556	1512	1468	1422	1380	1337	1325	1272	1195	1141
	Tap 3	Power / W	400	413	423	434	442	453	461	463	472	485	497
		CFM	1789	1748	1707	1665	1622	1578	1542	1534	1493	1447	1387
	Tap 4	Power / W	510	522	534	545	558	569	577	578	589	599	614
		CFM	1953	1923	1881	1843	1791	1742	1717	1717	1675	1643	1604
	Tap 5	Power / W	624	638	653	665	677	690	700	701	711	711	709
		CFM	2137	2096	2044	2013	1967	1918	1885	1875	1825	1783	1729
60	Tap 1	Power / W	206	215	224	232	240	250	264	266	275	284	294
		CFM	1419	1365	1311	1262	1213	1156	1060	1043	975	913	860
	Tap 2	Power / W	285	297	307	317	326	335	342	345	363	376	388
		CFM	1603	1554	1510	1463	1419	1374	1343	1327	1233	1154	1095
	Tap 3	Power / W	390	400	411	421	432	443	450	452	462	474	495
		CFM	1788	1746	1705	1664	1619	1577	1544	1534	1493	1444	1343
	Tap 4	Power / W	493	507	532	532	545	555	565	568	579	588	600
		CFM	1951	1911	1834	1833	1795	1761	1728	1719	1678	1649	1604
	Tap 5	Power / W	619	629	640	653	666	677	687	689	699	708	706
		CFM	2087	2055	2023	1982	1941	1909	1879	1873	1837	1807	1755

Table 17

**□** Bold outlined areas represent airflow outside of the required 300-450 cfm/ton range.

NOTES:

1. The high stage airflow must be used as the rated airflow for the full load operation of machine.
2. The rated airflow of systems without electric heater kits requires between 300 and 450 cfm/ton range.
3. The rated airflow of systems with electric heater kits requires between 350 and 450 cfm/ton range.
4. The air distribution system has the greatest effect on airflow. Therefore, the contractor should use only industry-recognized procedures.
5. Duct design and construction should be carefully done. System performance can be lowered dramatically through poor design or workmanship.
6. Air supplier ducts should be located along the perimeter of the conditioned space and properly sized. Improper location or insufficient air flow may cause drafts or noise in the ductwork.
7. Installers should balance the air distribution system to ensure proper quiet airflow to all rooms in the home. An air velocity meter or airflow hood can be used to balance and verify branch and system airflow (CFM).
8. Please refer to the wiring diagram for the default fan speeds for each model

## 5.1 Indoor Fan Motor Function

### System operation and function

#### Autofan Speed

The IDS Ultra series air handlers supports up to four stage fan control depending on the difference between the set point and room temperature when paired with a BCC connected thermostat. Otherwise, an estimated difference between room temperature and set point is used. This feature is only available when the unit is configured to communicating setup, refer to Section "12 Wiring Diagrams" on page 37 for more details.

The X13 ECM motor supports 5 different speeds. Customers can select the desired maximum and minimum fan speeds through adjusting the SW6-1 and SW6-2 dip switches. Refer to the airflow performance table (Table 17) and Figure 32 dip switch settings to determine the best way to configure the blower's speeds

#### Two Stage Fan Control Non-Auto Fan Speed

The IDS Ultra series air handler also supports two stage fan control which requires a two stage thermostat (Y1&Y2). When there is a call for Y2, the blower motor will turn to high speed setting. When there is a call for Y1, the blower motor will turn to low speed setting. Unit will run at low speed setting when there is only G call. It will run in high speed setting when there is W/W1/W2 signal (when the electric heat kit is on).

The X13 ECM motor supports 5 speeds. Customer can select the suitable speed by adjusting the SW6-1 and SW6-2 dip switches. Refer to Airflow Performance Table (Table 17) for reference airflow. Refer to Figure 32 for dip switches settings.

If 2 stage thermostat is not available, single stage thermostat may be used, please refer to Wiring Diagram section for wiring instructions. If Y1 and Y2 are jumped, the unit will only run in high stage fan speed.

#### Anti-Cold Air Fan Delay

The Anti-Cold Air Fan Delay function utilizes a temperature sensor (T2) located on the indoor coil and a pressure transducer (Pc) on the outdoor unit, which prevents the blower from turning on until the coil has reached a certain temperature. This feature prevents cold air blow during heating operation.

1. When SW6-3 dip switch is set to the "OFF" position and the unit is in heating mode, the Anti-Cold Air Fan Delay function will activate based on the following entry conditions (all 3 conditions must be met):
  - a. Indoor Coil Temperature (T2) < 83°F
  - b. Electric heat kit is turned off
  - c. There is a Y1 from the thermostat to the indoor unit
  
2. This function will deactivate if ONE OF the following exit conditions are met:
  - a. T2 ≥ 90°F for more than 2 minutes
  - b. Heater kit is turned on
  - c. The system is NOT running Heat mode
  - d. There is no longer a Y1 from the thermostat to the indoor unit
  - e. There is a communication fault between indoor unit and outdoor unit
  
3. During the heating mode, the blower motor will turn on in first stage fan speed if one of the following conditions of Anti-Cold Air is satisfied:
  - a. T2 ≥ 90F
  - b. Pc ≥ 435 psi
  - c. Anti-Cold Air Fan Delay have been activated for 15 minutes



---

Air handlers connected to water source heat pumps, or off brand units that energize the reversing valve with a call for cooling, should not run the O/B wire to the air handler. This will cause the anti cold air fan delay to trigger on a call for cooling.

---

#### Heating Fan Delay

If SW6-3 dip switch is set to the "ON" position and the unit is in heating mode, the blower will operate with a 90 second delay with the fan speed dictated by Y1 or Y2 signal.

#### Dehumidification (Optional)

The IDS Ultra series air handler has active and passive dehumidification modes depending on the wiring to the outdoor unit. When the air handler is paired with an IDS Ultra series condensing unit, a DH call from a thermostat will lower the evaporator temperature and slow down the fan speed to dehumidify the space. Otherwise, only the fan speed will be lowered.



---

If DH wire is not connected, the unit will still function normally.

---

## 6 Ductwork

Field ductwork must comply with the National Fire Protection Association NFPA 90A, NFPA 90B and any applicable local ordinance(s).

### **WARNING**

#### **Fire hazard and carbon monoxide!**

Do not, under any circumstances, connect return ductwork to any other heat producing device such as fireplace insert, stove, etc. Unauthorized use of such devices may result in fire, carbon monoxide poisoning, explosion, personal injury or property damage.

Sheet metal ductwork run in unconditioned spaces must be insulated and covered with a vapor barrier. Fibrous ductwork may be used if constructed and installed in accordance with SMACNA Construction Standard on Fibrous Glass Ducts. Ductwork must comply with National Fire Protection Association as tested by U/L Standard 181 for Class I Air Ducts. Check local codes for requirements on ductwork and insulation.

- Duct system must be designed within the range of external static pressure the unit is designed to operate against. It is important that the system airflow be adequate. Make sure supply and return ductwork, grills, special filters, accessories, etc. are accounted for in total resistance. See airflow performance tables in "5 Airflow Performance" on page 28 of this manual.
- Design the duct system in accordance with "ACCA" Manual "D" Design for Residential Winter and Summer Air Conditioning and Equipment Selection. Latest editions are available from: "ACCA" Air Conditioning Contractors of America, 1513 16th Street, N.W., Washington, D.C. 20036. If duct system incorporates flexible air duct, be sure pressure drop information (straight length plus all turns) shown in "ACCA" Manual "D" is accounted for in system.
- Supply plenum should be attached to the 3/4" duct flanges supplied with the unit. Attach flanges around the blower outlet.



If an elbow is included in the plenum close to the unit, it must not be smaller than the dimensions of the supply duct flange on the unit.



The front flange on the return duct (if connected to the blower casing) must not be screwed into the area where the power wiring is located. Drills or sharp screw points can damage insulation on wires located inside unit.

- Secure the supply and return ductwork to the unit flanges, using proper fasteners for the type of duct used and tape the duct-to-unit joint as required to prevent air leaks.



### **WARNING**

#### **Fire, explosion!**

If appliances connected via an air duct system to one or more rooms are installed in a room with an area less than shown in "3.5 Refrigerant Charge and Room Area Limitations" on page 19, that room shall be without continuously operating open flames (e.g. an operating gas appliance) or other potential ignition sources (for e.g. an operating electric heater, hot surfaces). A flame-producing device may be installed in the same space if the device is provided with an effective flame arrest. For appliances connected via an air duct system to one or more rooms, auxiliary devices which may be a potential ignition source shall not be installed in the duct work. Examples of such potential ignition sources are hot surfaces with a temperature exceeding 700°C and electric switching devices. For appliances connected via an air duct system to one or more rooms, only auxiliary devices approved by the appliance manufacturer or declared suitable with the refrigerant shall be installed in connecting ductwork.

## 7 Refrigerant Connections

The suction pipe and liquid pipe of the indoor unit need to be protected and cannot be grabbed when moving the indoor unit.

Keep the coil connections sealed until refrigerant connections are made. Refer to the outdoor unit Installation, Operation, and Maintenance Manual for details on line sizing, tubing installation, and charging information.

Coil is factory charged with Nitrogen. Evacuate the system before charging with refrigerant.

Install refrigerant lines so that they do not block service access to the front of the unit.

Nitrogen should flow through the refrigerant lines while brazing.

Use a brazing shield to protect the cabinet's paint and a wet rag to protect the rubber grommet and input pipe's piston seal ring from being damaged by torch flames. Use a wet rag or an approved heat paste to protect the TXV sensing bulb during the brazing process. Refer to Figure 16.

After the refrigerant line connections are made, seal the gap around the connections with pressure sensitive gasket.

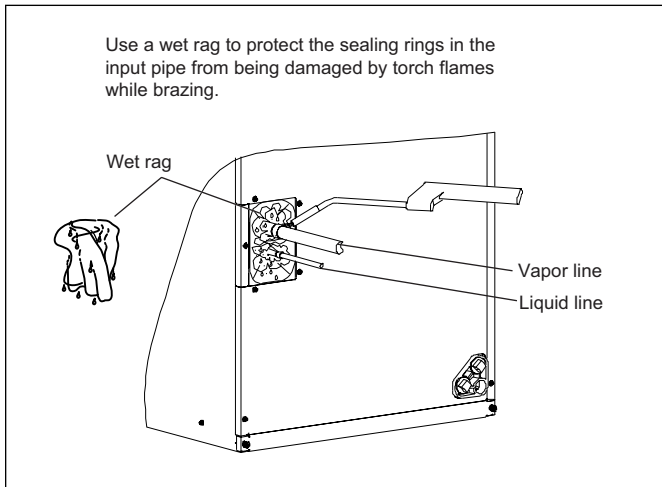

Figure 16

After the brazing work is finished, make sure to check that there is no refrigerant leakage. After checking for vapor leaks, be sure to insulate the pipe connections, refer to Figure 17.

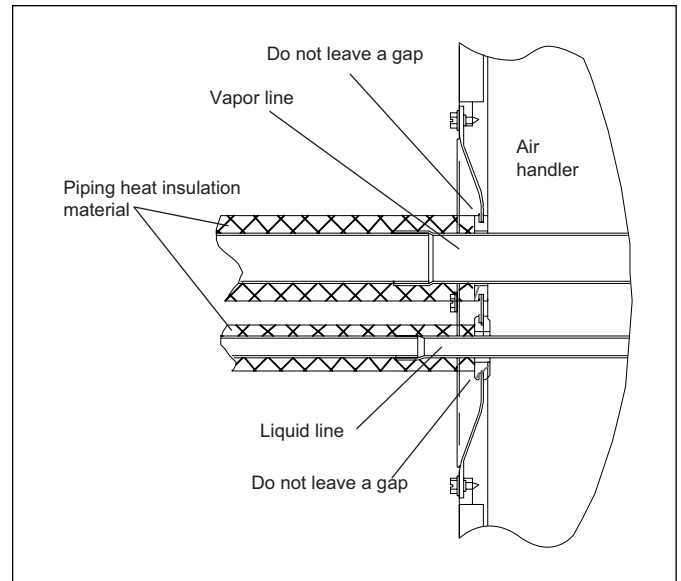

Figure 17

## 8 Condensate Drain Connection

Consult local codes for specific requirements.

Refer to Figure 18 and the information below for required condensate drain trap installation.

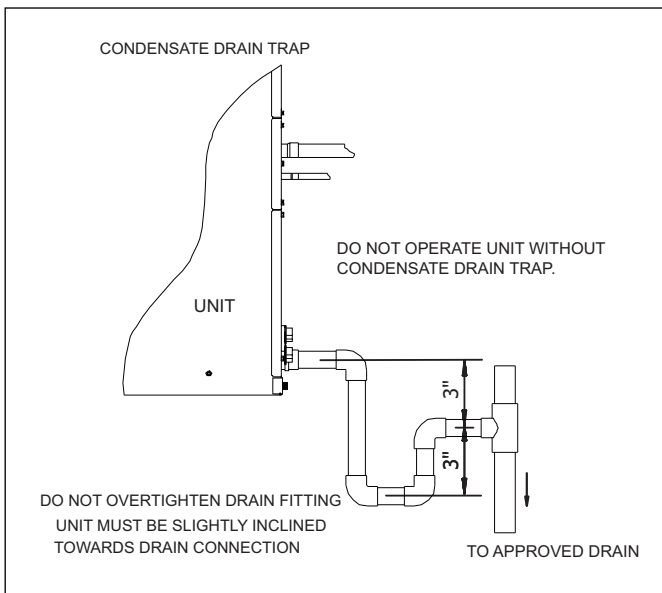

Figure 18



1. When making drain fitting connections to the drain pan, use a thin layer of Teflon paste, silicone or Teflon tape and install by hand tightening.
2. When making drain fitting connections to drain pan, do not overtighten. Over tightening fittings can split pipe connections on the drain pan.

- Ensure drain lines do not block access to front of the unit. Minimum clearance of 24 inches is required for filter, coil or blower removal and service access.
- Make sure unit is leveled or pitched slightly toward primary drain connection so that water will drain completely from the pan. Up to an additional 1/4" rise over the width or depth of the unit is allowed to create additional sloping towards the drain. Unit must be positioned between level and 1/4" rise ,sloping toward the drain connections. See Figure 19 to Figure 22 for reference.
- Do not reduce drain line size to less than connection size provided on condensate drain pan. Use 3/4" PVC piping for the drain piping connections.
- All horizontal drain lines must be pitched downward away from the unit at a minimum of 1/8" per foot of line to ensure proper drainage.
- Do not connect condensate drain line to a closed or open sewer pipe. Run condensate to an open drain or run line to a safe outdoor area.
- The drain line should be insulated where necessary to prevent sweating and damage due to condensate forming on the outside surface of the line.
- Make provisions for disconnecting and cleaning of the primary drain line should it become necessary. Install a 3 inch trap in the primary drain line as close to the unit as possible. Make sure that the top of the trap is below connection to the drain pan to allow complete drainage of pan (See Figure 18).

- Auxiliary drain line should be run to a place where condensate will be noticeable. Homeowner should be warned that a problem exists if water should begin running from the auxiliary drain line.
- Plug the unused drain connection with the plugs provided in the parts bag provided with the unit. Use a thin layer of teflon paste, silicone or teflon tape to form a water tight seal.
- Test condensate drain pan and drain line after installation is complete. Pour water into drain pan, enough to fill drain trap and line. Check to ensure drain pan is draining completely, no leaks are found in drain line fittings, and water is draining from the termination of the primary drain line.
- Be sure to insulate the drain piping and drain socket since condensation may cause water leakage.
- Be sure to install a drain tap at the drain outlet since the inside of the unit is at negative pressure relative to atmospheric pressure during operaiton.

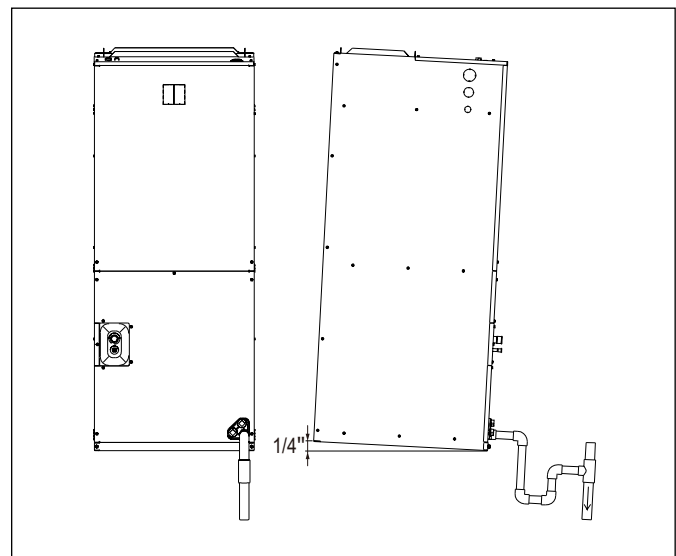

Figure 19 Vertical upflow view

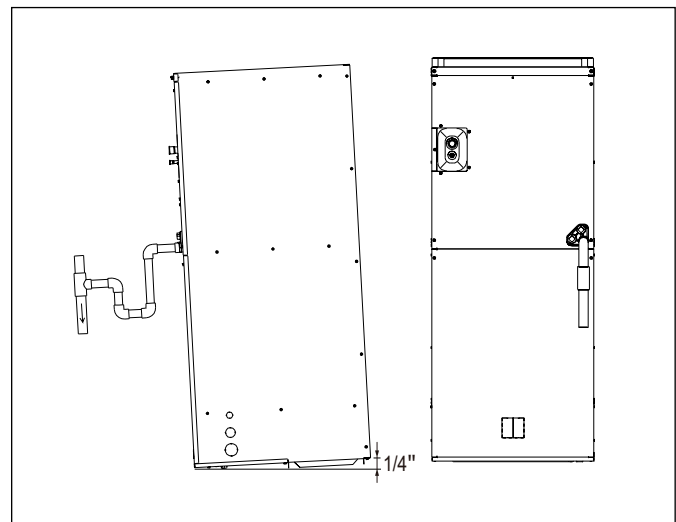

Figure 20 Vertical downflow view

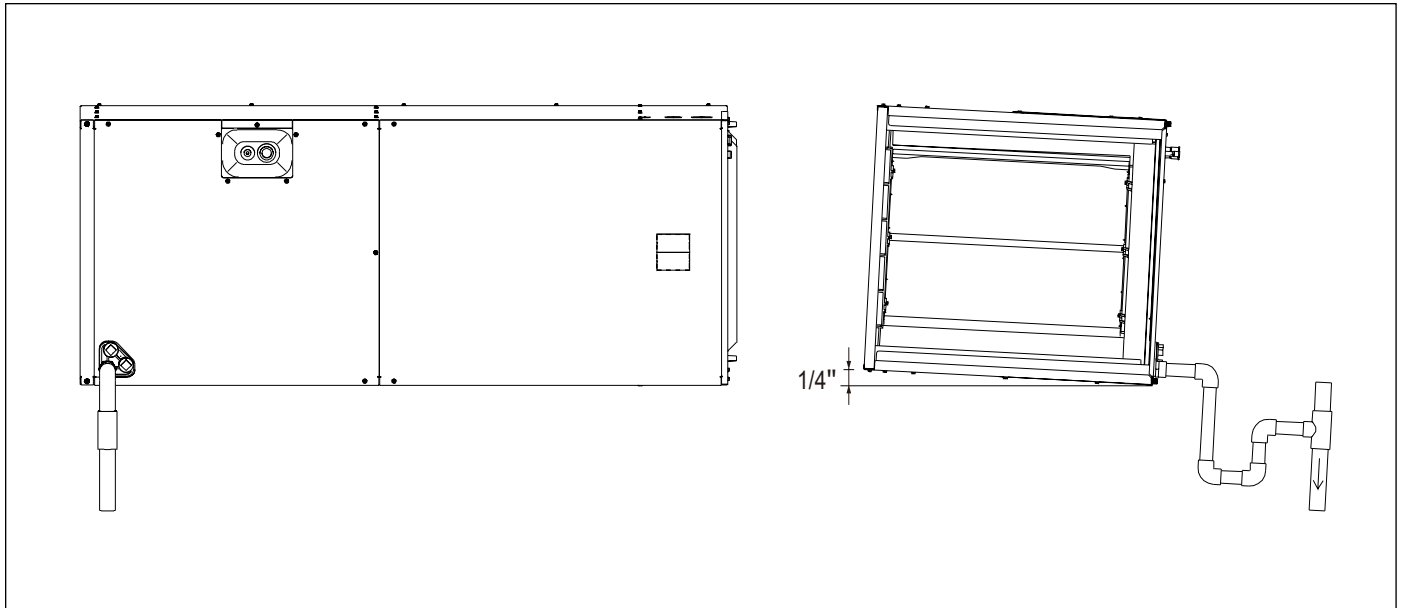

Figure 21 Horizontal right view

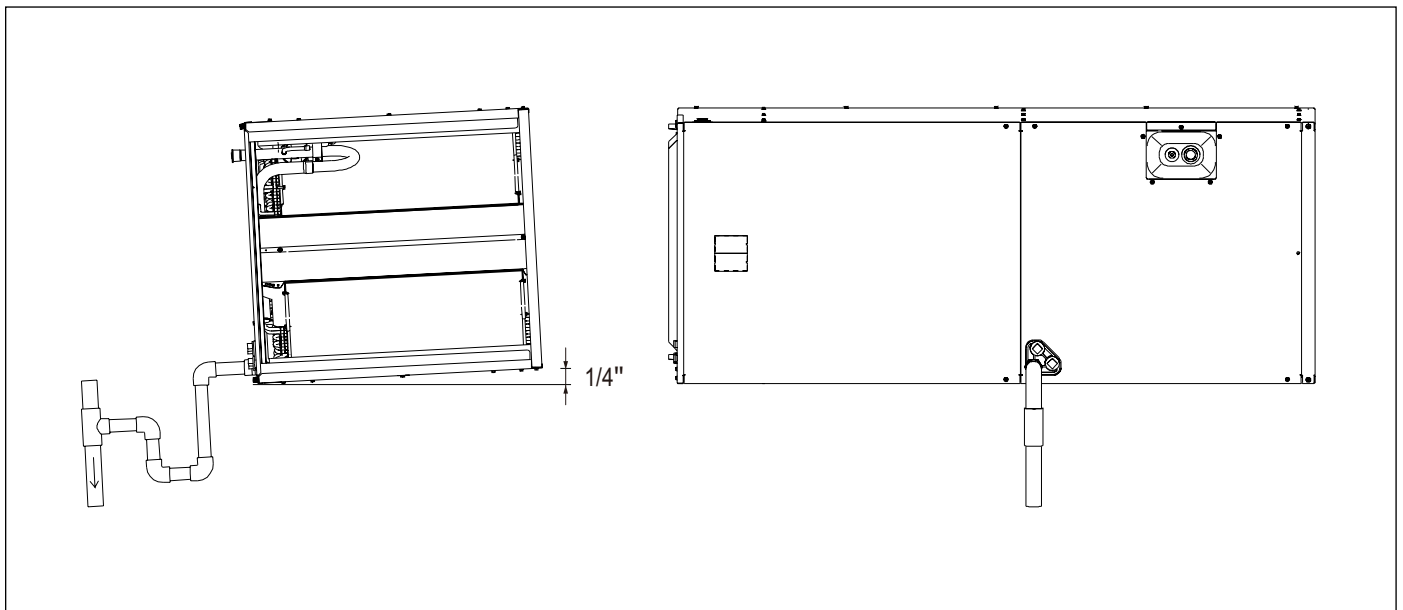

Figure 22 Horizontal left view

---

## 9 Air Filter (Not Factory-Installed)

Filters are not included with the unit and must be field supplied.

An external filter or other means of filtration must be properly sized for a maximum of 300 feet/min. air velocity or what is recommended for the type of filter installed.

Filter application and placement are critical to airflow, which may affect the heating and cooling system performance. Reduced airflow can shorten the life of the system's major components, such as motor, elements, heat relays, evaporator coil or compressor. Consequently, we recommend that the return air duct system have only one filter location. For systems without a return air filter grill, multiple filter grills can be installed at each of the return air openings.

If adding high efficiency filters or electronic air filtration systems, it is very important that the air flow is not reduced. If air flow is reduced the overall performance and efficiency of the unit will be reduced. It is strongly recommended that a professional installation technician is contacted to ensure such filtration systems are installed correctly.

Filters with MERV ratings between 8-11 are recommended. Any installed filters with a MERV rating above 11 will negatively impact air flow and system performance.



---

Do not double filter the return air duct system. Do not filter the supply air duct system. This will change the performance of the unit and reduce airflow.

---



### **WARNING**

#### **Fire hazard!**

Do not operate the system without filters. A portion of the dust suspended in the air may temporarily lodge in the duct runs and at the supply registers. Any circulated dust particles could be heated and charred by contact with the air handler elements. This residue could soil ceilings, walls, drapes, carpets and other articles in the house. Soot damage may occur with filters in place, when certain types of candles, oil lamps or standing pilots are burned.

---

**9.1 Filter Installation Dimensions**

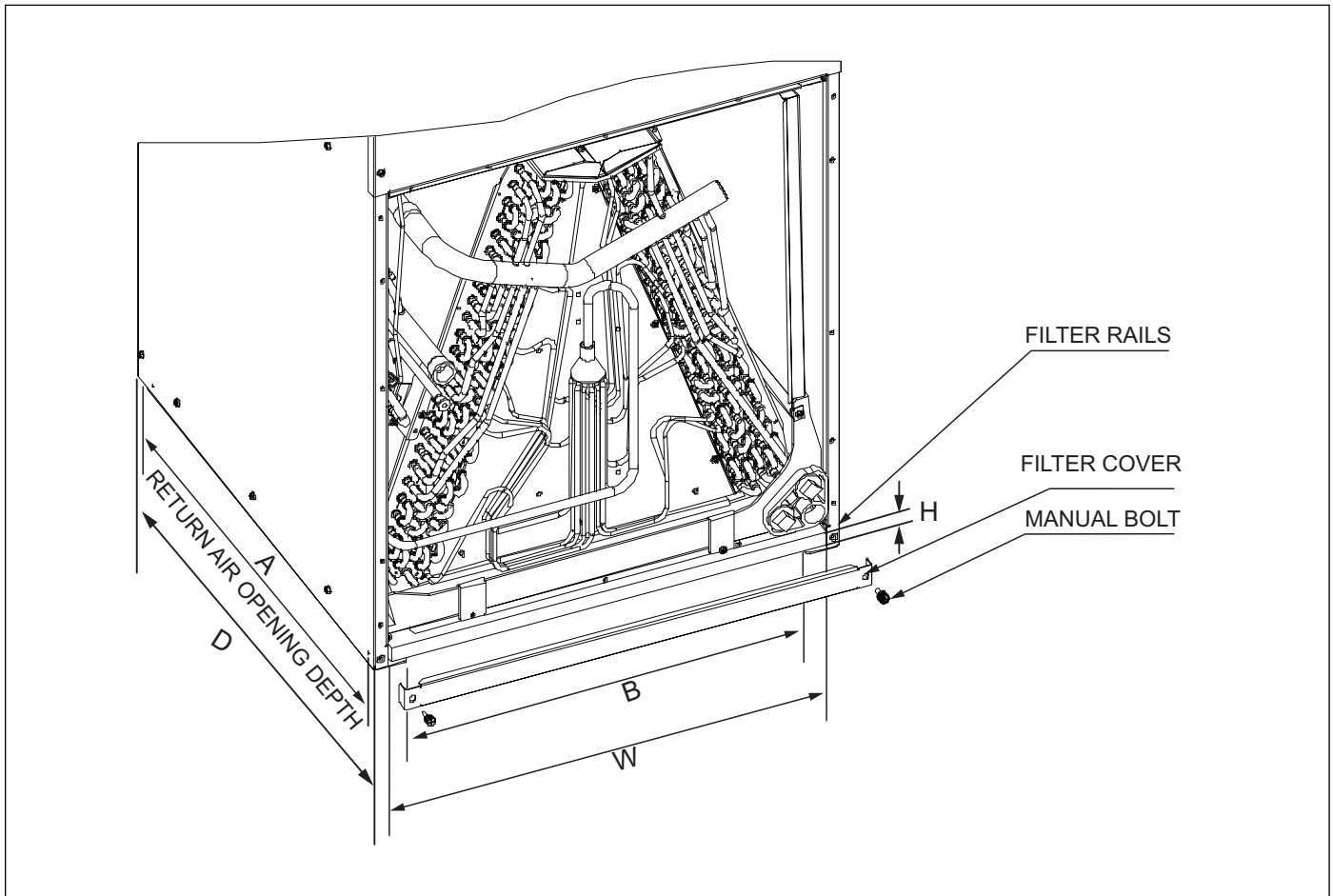

Figure 23 Filter installation



Filters are not included with the unit and must be field supplied.

**Dimensional data**

Model	Filter Size In. [mm]	"W" In. [mm]	"D" In. [mm]	"H" In. [mm]	Return width "A" In. [mm]	Return length "B" In. [mm]
36	18X20 [457X508]	18.3 [466]	21.6 [548]	1 [25.4]	20.8 [528.3]	16.3 [414]
48/60	20X22 [508X559]	20.7 [526]	23.9 [608]	1 [25.4]	23 [584.2]	18.8 [477.5]

Table 18

**Air filter removal / installation**

- Remove screws manually, remove air filter cover, see Figure 23.
- Hold the edge of the air filter and pull out.
- Install new filter so that the arrow on the filter is in the same direction as airflow.
- If reusable filter is being used, please clean according to the manufacturer's specification prior to re-installation.

---

## 10 Maintenance



---

For continuing high performance and to minimize possible equipment failure, periodic maintenance must be performed on this equipment.

---

### 10.1 Cleaning Precautions

**WARNING**

**Improper or dangerous operation, personal injury!**

Any unit repairs must be performed by qualified service personnel only.

---

**WARNING**

**Electrical shock!**

Always turn off your heat pump and disconnect its power supply before cleaning or maintenance.

---

**CAUTION**

**Personal injury!**

When removing filter, do not touch metal parts in the unit. The sharp metal edges can cut you.

---

**NOTICE**

**Product damage!**

Do not use chemicals or chemically treated cloths to clean the unit .

Do not use benzene, paint thinner, polishing powder or other solvents to clean the unit.

Do not operate the system without a filter in place.

---

### 10.2 Regular Maintenance

Your heat pump must be inspected regularly by a qualified service technician. Your annual system inspection must include:

1. Inspect the air filter every ninety days or as often as needed. If blocked or obstructed, clean or replace at once.
2. Inspection and/or cleaning of the blower wheel housing and motor.
3. Inspection and cleaning of indoor and outdoor coils as required.
4. Inspection and/or cleaning of the indoor coil drain pan and drain lines, as well as auxiliary drain pan and lines.
5. Check all electrical wiring and connections. Correct as needed, referring to the wiring diagram.

---

## 11 Disposal

Components and accessories from the units are not part of ordinary domestic waste.

Complete units , compressors, motors etc. are only to be disposed of via qualified disposal specialists.

This unit uses hydrogen fluorocarbons. Please contact the dealer when you want to dispose of this unit. Law requires that the collection, transportation and disposal of refrigerants must conform with the regulations governing the collection and destruction of hydrofluorocarbons.

---

## 12 Wiring Diagrams

**WARNING****Electrical shock!**

Disconnect all power before servicing or installing this unit. Multiple power sources may be present. Failure to do so may cause property damage, personal injury or death.

---

**DANGER****Electrical shock!**

This unit must be properly grounded and protected by a circuit breaker or fuse.

---

**WARNING****Electrical shock!**

These units must be wired and installed in accordance with all National and Local Safety Codes.

---

- To avoid electrical shock, please ensure:
  - The heat pump is properly grounded
  - The main power plug to the heat pump has been joined with the ground wiring (DO NOT ALTER THIS).
- Do not strain the power wiring.

Low-voltage wires include indoor unit connect with outdoor unit and the indoor unit connect with the thermostats.

Hyper-Link (M1 M2) communication mode is only available for specified models.



---

Dashed lines in the following thermostat wiring diagrams refer to optional wiring (wiring for Passive Dehumidification Function and/OR Electric Heat). For thermostat wiring please refer to the Owner's Manual of the thermostat.

---



---

Dh wiring is optional and requires a thermostat with a humidistat. Dh functions as Passive Dehumidification and will downstage the indoor fan to first stage. System will operate according to normal sequence of operations if Dh wiring is absent.

---

## 12.1 Communicating Set Up

### Dip switch configurations for communicating mode (default)

Communication mode is the factory default for this system.

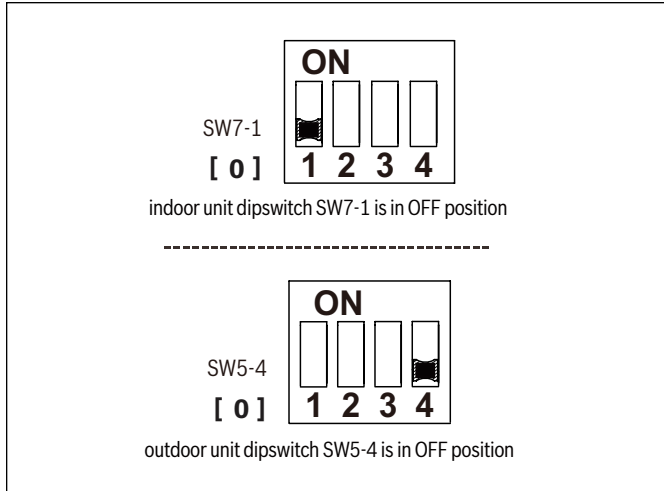

Figure 24



- The factory default mode is Hyper-Link(M1 M2) communication between the outdoor and indoor units and 24VAC connection with the thermostat.
- Hyper-Link(M1 M2) communication mode is only available with a matched outdoor unit which has Hyper-Link(M1 M2) communication function.
- If there are 2 or more systems (communication) in the same area, make sure the low voltage wires are connected to the right unit that are connected to the same refrigerant line.
- The IDS Ultra AHU (BIVB19) can only be configured to communicating mode when installed with an IDS Ultra ODU (BOVB19).

### Low voltage wire connections with the outdoor unit, communicating

1. Peel off the half-stripped wires of the pre-installed communication wires
2. Connect the Hyper-Link(M1M2)communication wires to the field supplied wires

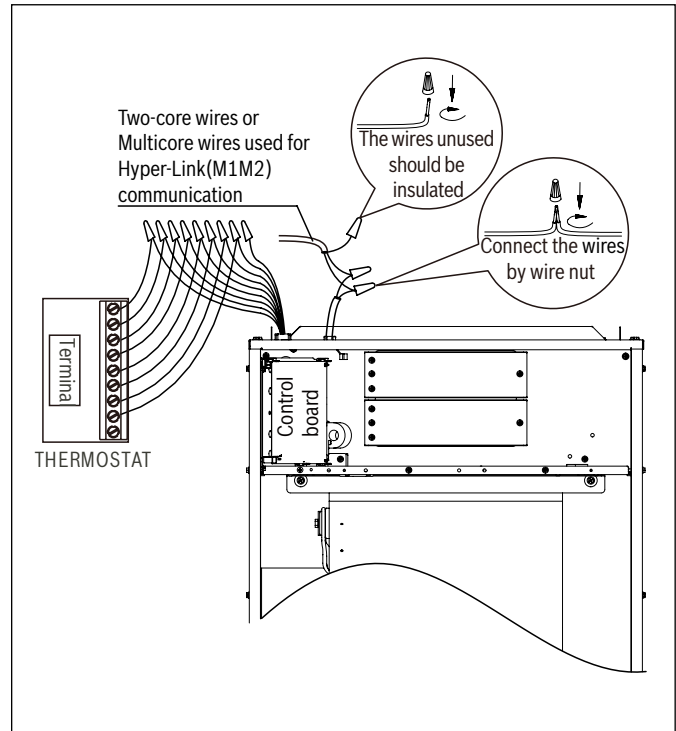

Figure 25

**Communicating thermostat wiring diagrams**

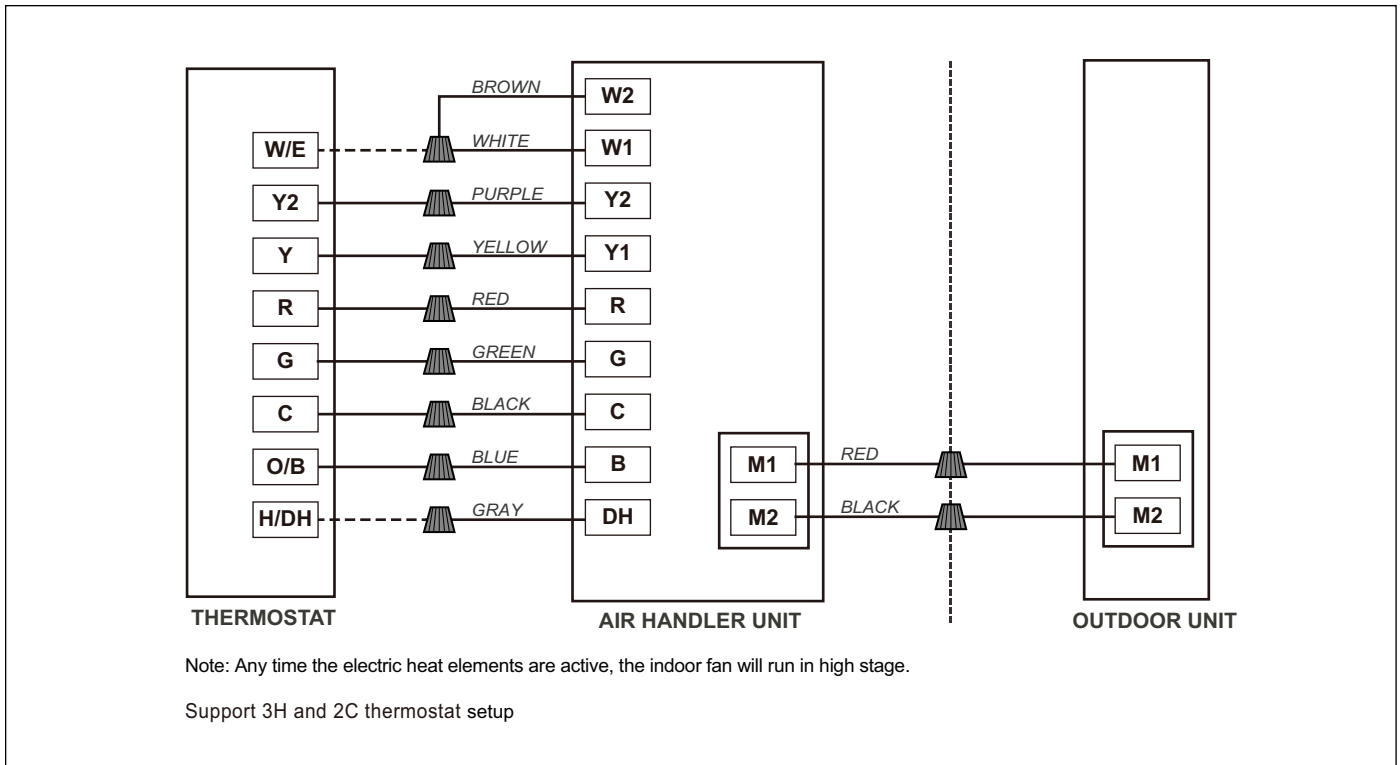

Figure 26 Control wiring for HP systems

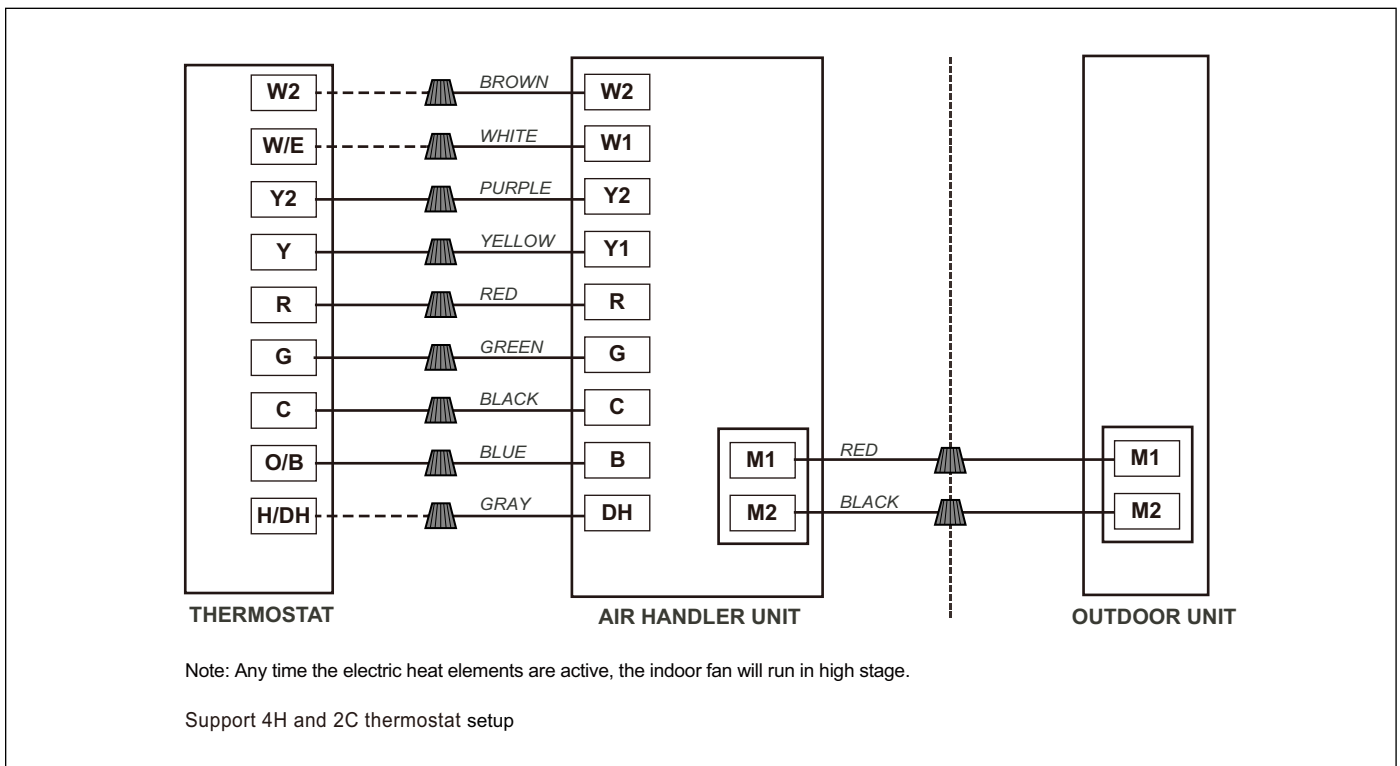

Figure 27 Control wiring for HP systems

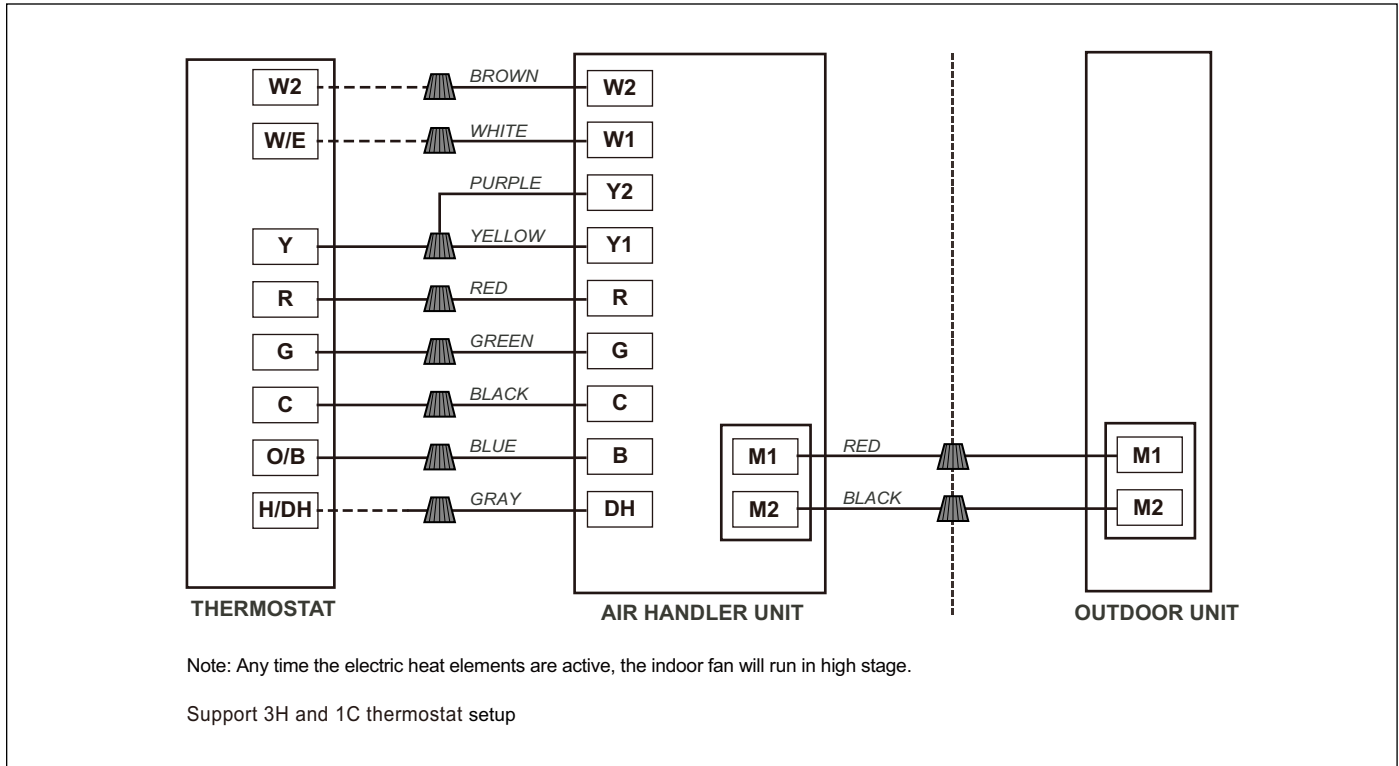

Figure 28 Control wiring for HP systems

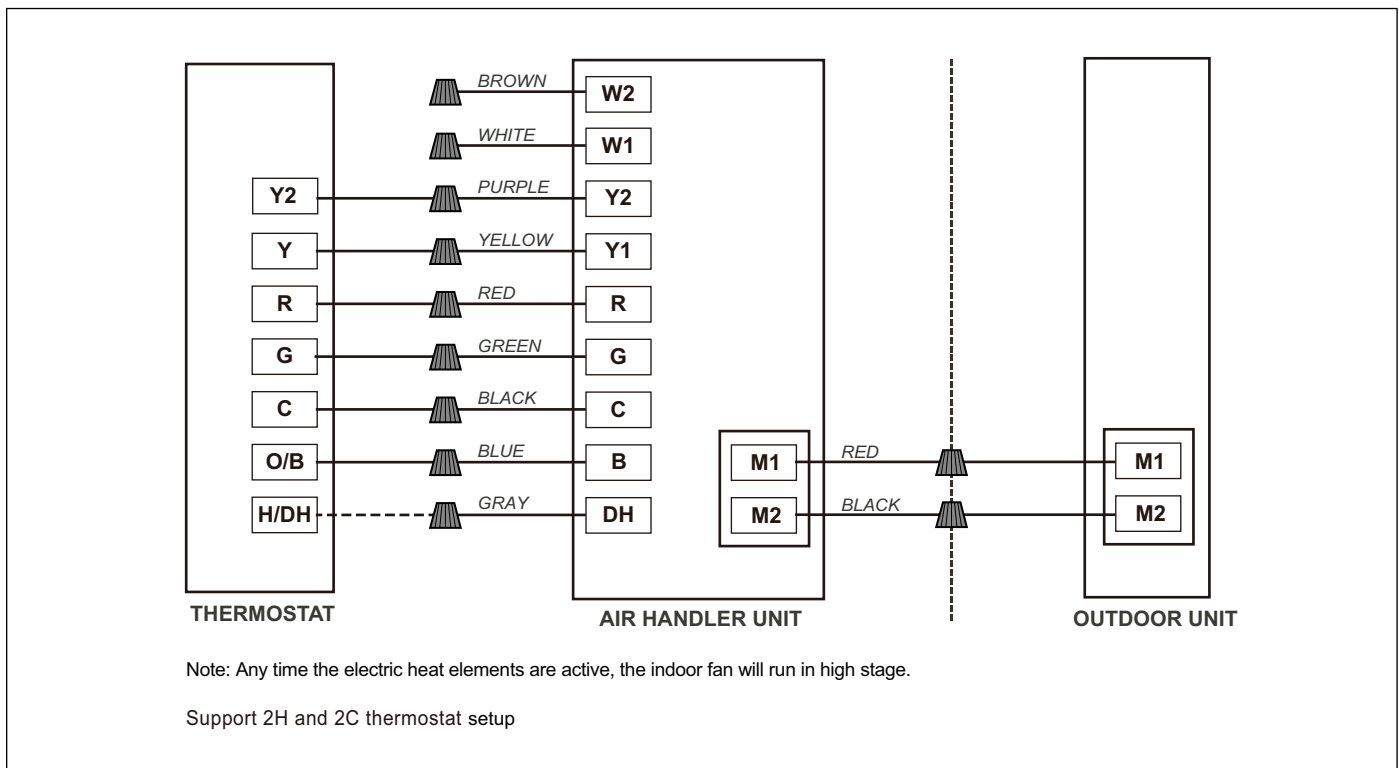

Figure 29 Control wiring for HP systems

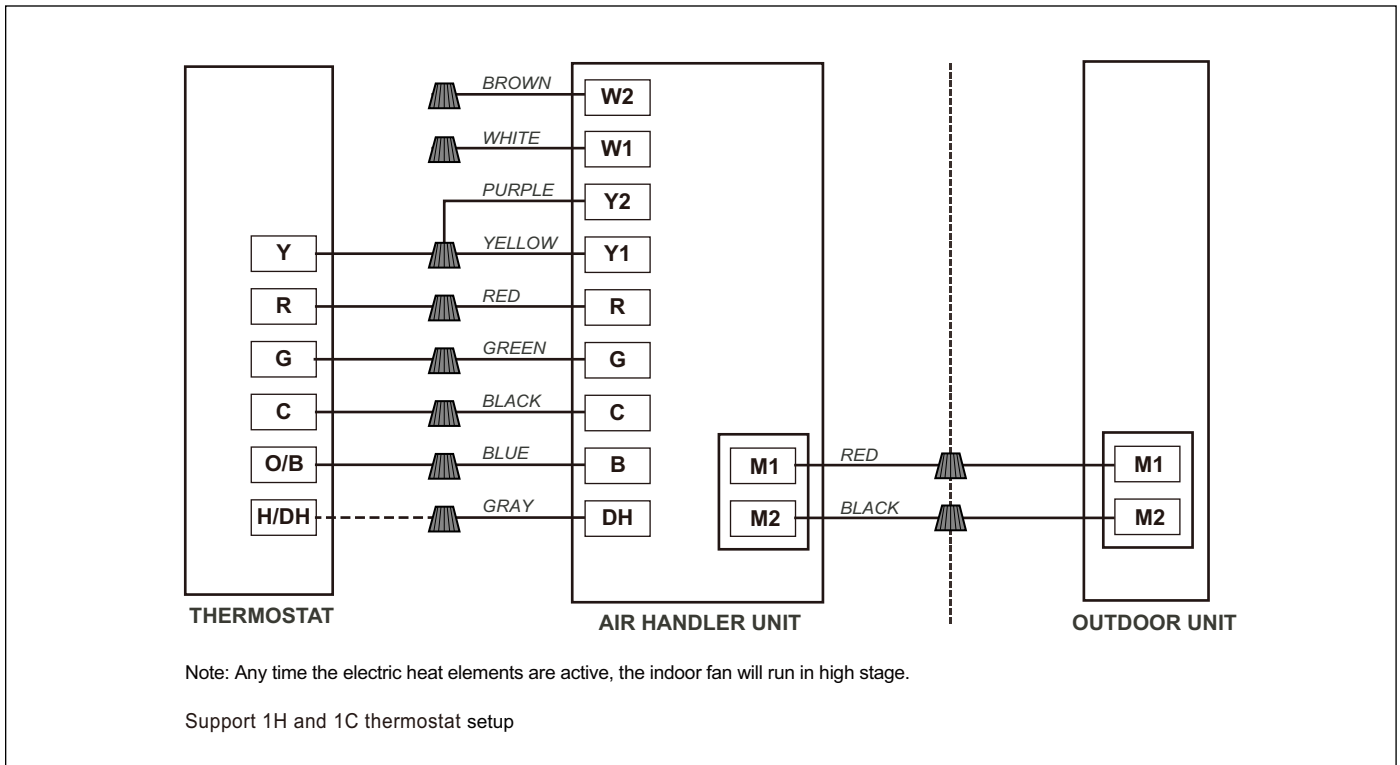

Figure 30 Control wiring for HP systems

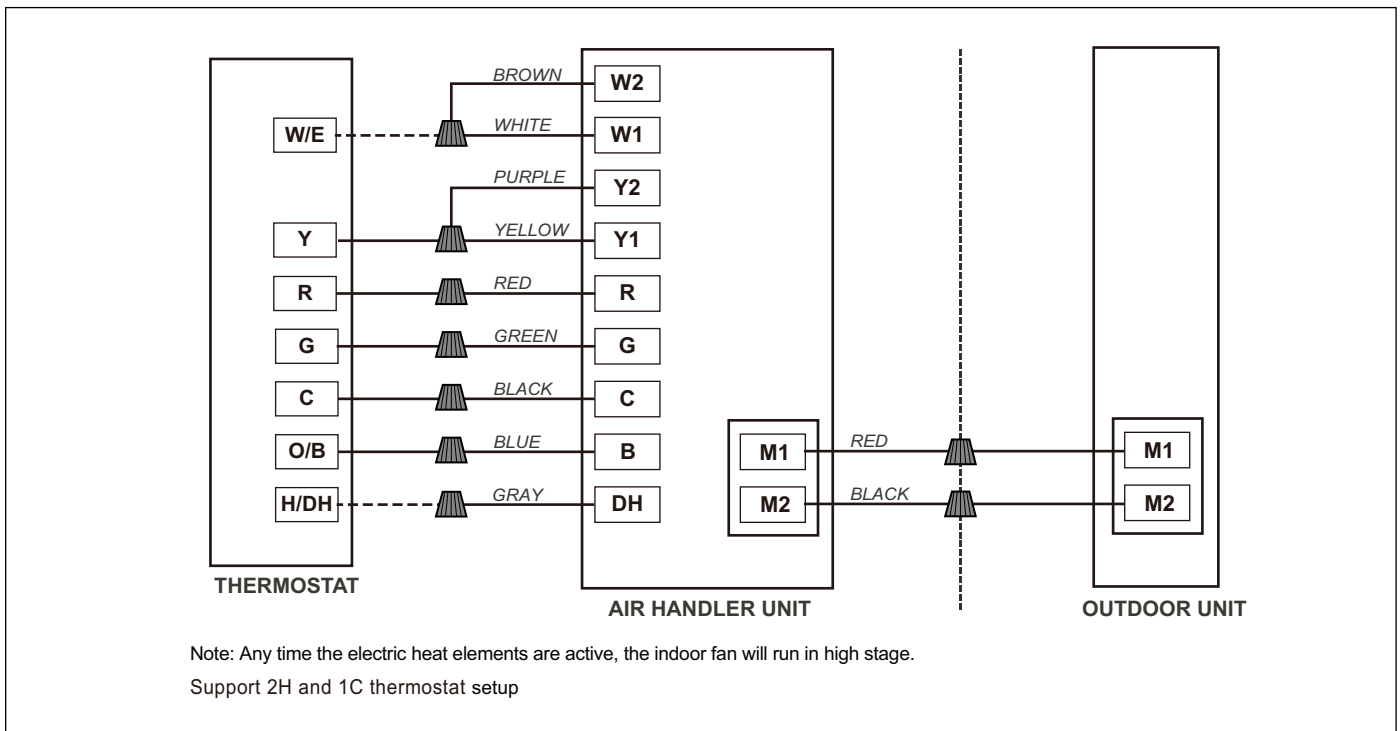

Figure 31 Control wiring for HP systems

# WIRING DIAGRAM

SEE NAME PLATE FOR VOLT&HERTZ  
FIELD POWER WIRING

**CAUTION:**  
NOT SUITABLE FOR USE ON SYSTEMS EXCEEDING 150V TO GROUND.

**ATTENTION:**  
NE CONVIENT PAS AUX INSTALLATIONS DE PLUS DE 150V A LA TERRE.

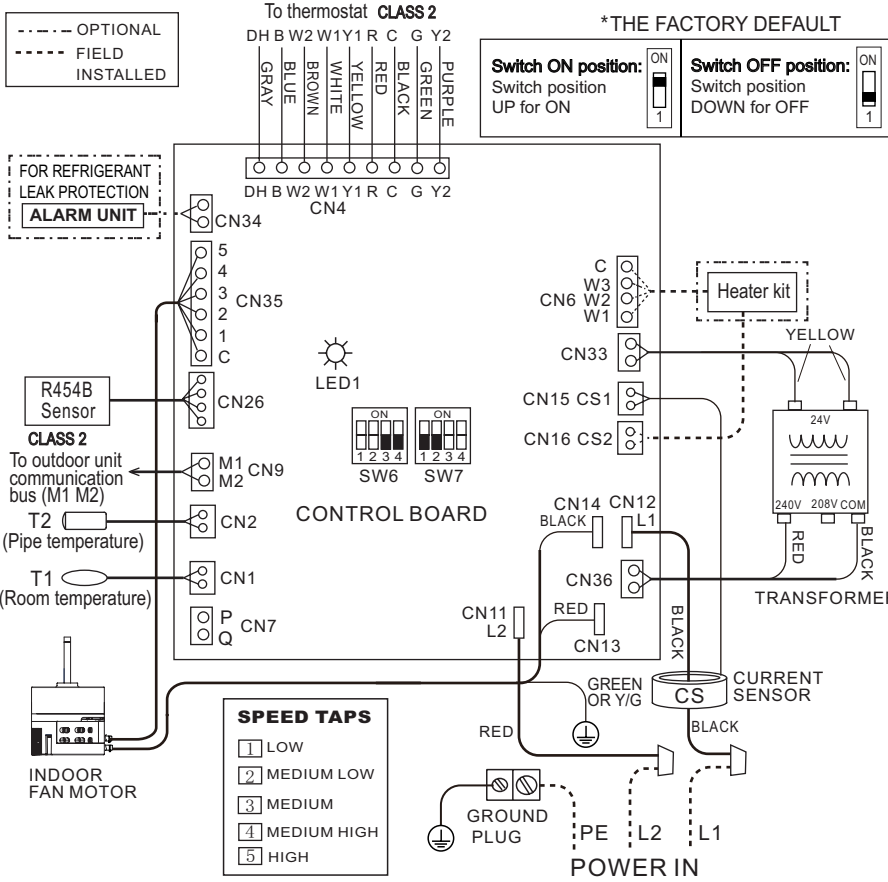

### DIP SWITCH SETTING

NON-AUTOFAN SPEED			
DIP SWITCH	Y1 OR G (MIN)	Y1+Y2 OR W1/W2 (MAX)	
ON	COOL	1	2
ON	HEAT	1	3
ON	COOL	1	3
ON	HEAT	2	4
ON	COOL	2	4
ON	HEAT	3	5
ON	COOL	3	5
ON	HEAT	3	5
AUTOFAN SPEED (COMMUNICATION MODE ONLY)			
DIP SWITCH	MIN	MAX	
ON	COOL	1	2
ON	HEAT	1	3
ON	COOL	1	3
ON	HEAT	1	4
ON	COOL	1	4
ON	HEAT	2	5
ON	COOL	2	5
ON	HEAT	2	5
<b>SW6-3</b>	ON	NON-ANTI-COOLAIR	
<b>SW6-3</b>	OFF	ANTI-COOLAIR	*
<b>SW6-4</b>	ON	NON-AUTOFAN SPEED	
<b>SW6-4</b>	OFF	AUTOFAN SPEED	*
<b>SW7-1</b>	ON	RESERVED	
<b>SW7-1</b>	OFF	COMMUNICATION MODE	*
<b>SW7-2</b>	ON	RESERVED	
<b>SW7-2</b>	OFF	NORMAL	
<b>SW7-3,4</b>	unused	36K	48K
<b>SW7-3,4</b>	unused	36K	60K

- NOTES:**
- 1: If connected to the 1-Stage thermostat, please jump the signals Y1 and Y2.
  - 2: If some wires of CN4 are not used, please cap them with wire nuts individually.

- CAUTION:**
- 1: Use copper wire (75°C min) only between disconnect switch and unit.
  - 2: Wire the system per NEC and local codes.
  - 3: If any of the factory wiring has to be replaced, use the same or equivalent type of wires.
  - 4: If the incoming voltage is 208V, please move the red wire on the transformer from the 240V tap to the 208V tap.
  - 5: The rated operating condition of **Alarm** is 24 VAC/1A or 30 VDC/1A or 250 VAC/1A. Please refer to the manual for wiring methods.

LED1 STATUS	CONTENT
STEADY ON	NORMAL OPERATION
OFF	POWER SUPPLY FAILURE
KEEP FLASHING	REFRIGERANT LEAK PROTECTION
1FLASH/CYCLE	TEMPERATURE SENSOR FAULT (T1)
2FLASH/CYCLE	TEMPERATURE SENSOR FAULT (T2)
3FLASH/CYCLE	R454B REFRIGERANT SENSOR FAULT
4FLASH/CYCLE	R454B REFRIGERANT SENSOR COMMUNICATION FAULT
5FLASH/CYCLE	COMMUNICATION FAULT BETWEEN INDOOR UNIT AND OUTDOOR UNIT
6FLASH/CYCLE	POWER CONSUMPTION SENSOR FAULT
8FLASH/CYCLE	R454B SENSOR OUT OF SERVICE LIFE

Figure 32 Indoor unit wiring diagram

### 13 LED Flashing Troubleshooting

Indoor unit fault codes can be diagnosed via observing the behavior of LED1. The number of flashes per cycle correspond to certain faults as described below.

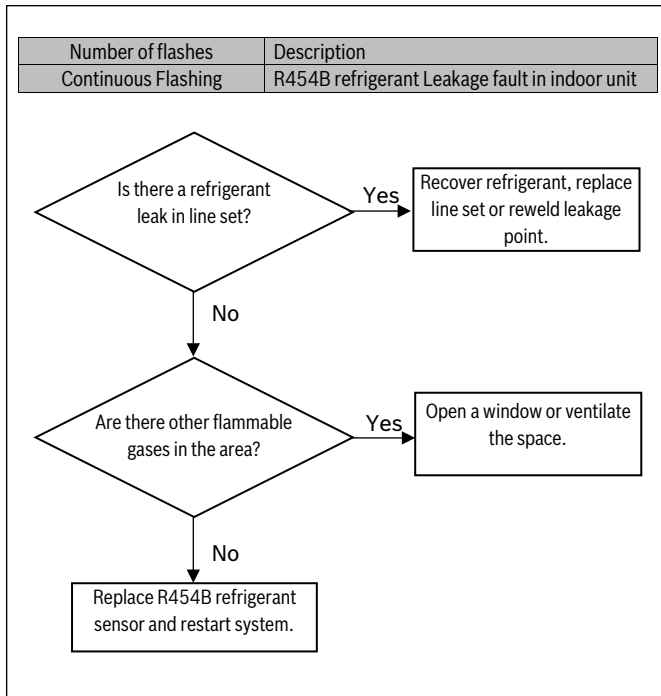

Figure 33

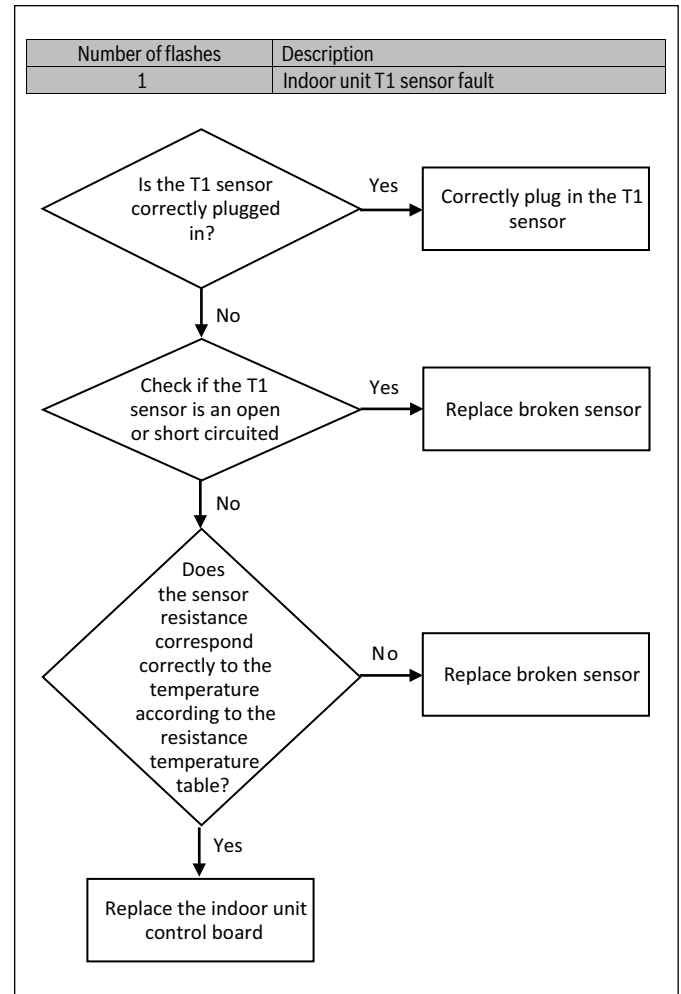

Figure 34

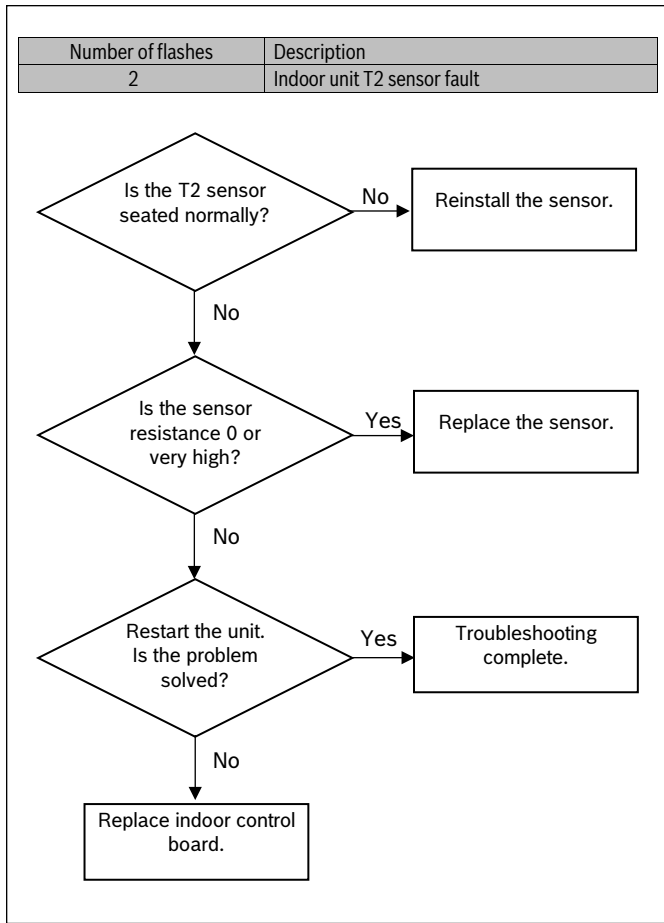

Figure 35

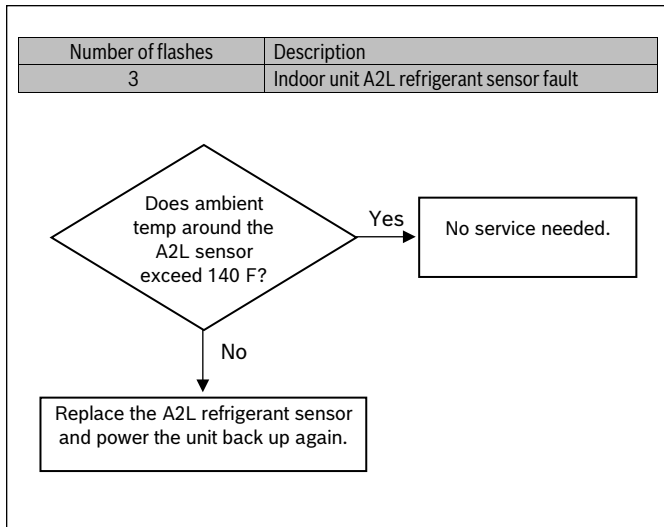

Figure 36

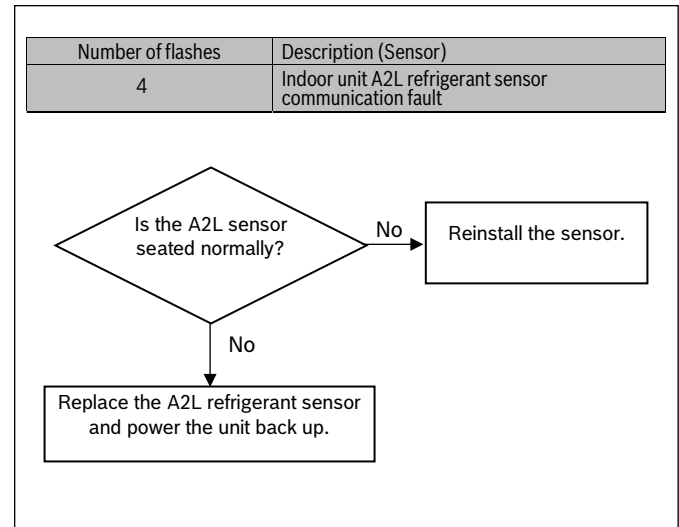

Figure 37

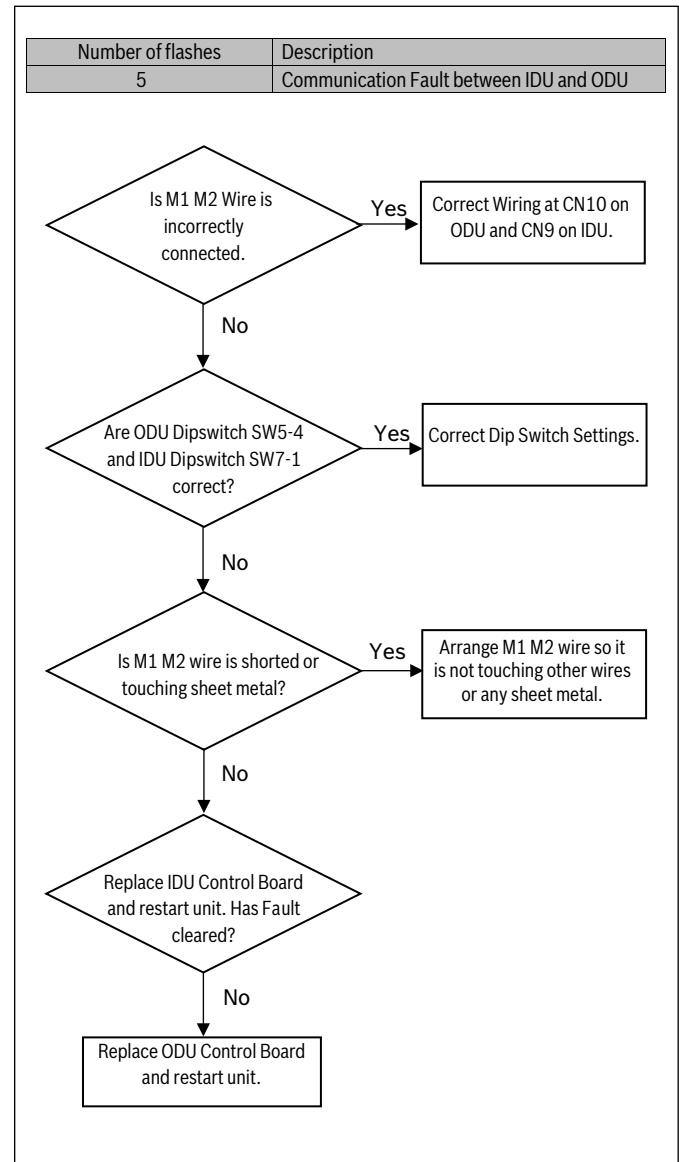

Figure 38

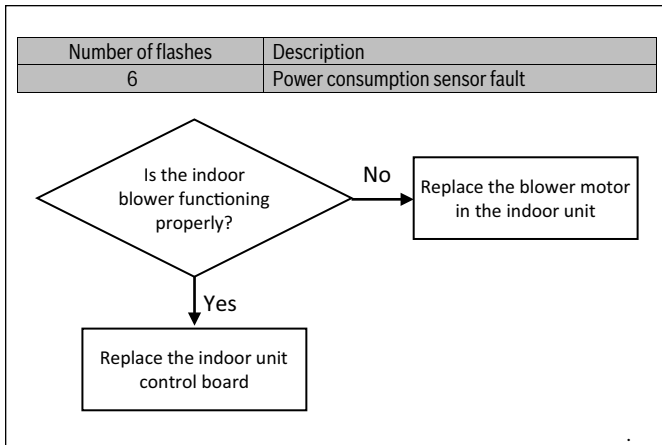

Figure 39

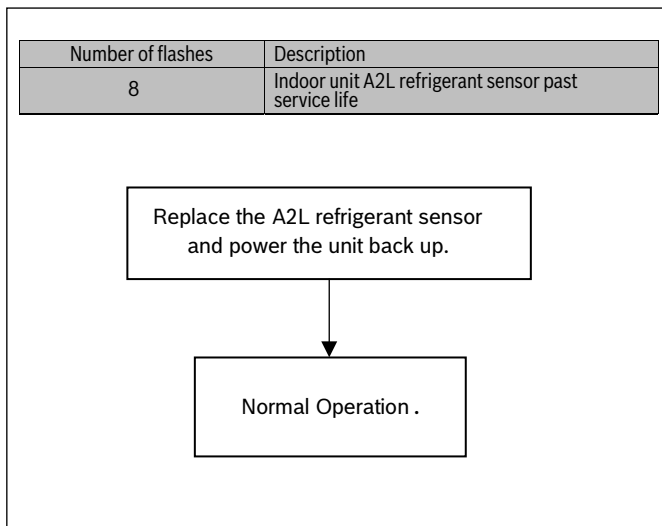

Figure 40

**Online Help Resources**

Alternatively, please visit our Service & Support webpage to find FAQs, videos, service bulletins, and more; [www.boschheatingcooling.com/service](http://www.boschheatingcooling.com/service) or use your cellphone to scan the code below.

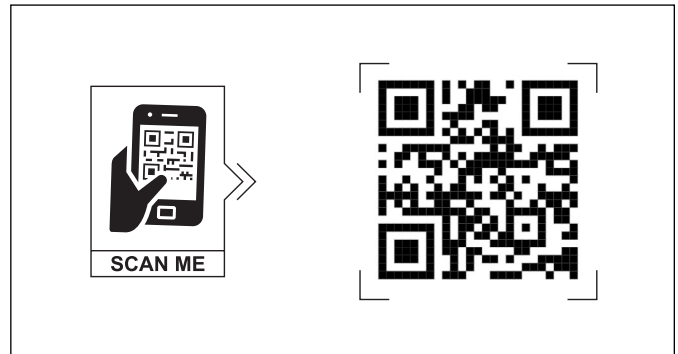

Figure 41

**NOTES:**

**NOTES:**

**United States and Canada  
Bosch Thermotechnology Corp.  
65 Grove St.  
Watertown, MA 02472**

**Tel: 800-283-3787  
[www.bosch-homecomfort.us](http://www.bosch-homecomfort.us)**

**BTC 762003306 H / 02.2026**

**Bosch Thermotechnology Corp. reserves the right to  
make changes without notice due to continuing  
engineering and technological advances.**

**Version Française**

