

VURSA kd, 4-Piece Installations

Oasis®

Tub/Showers: TS4P-5429 (all versions) TS4P-6030 (all versions) TS4P-6032 (all versions)

Showers: SH4P-6030 (all versions) SH4P-6032 (all versions)



TS4P-5429L ABF (shown)



SH4P-6030L-RS ABF (shown)



SH4P-6032 ABF (shown)



TS4P-6032L ABF (shown)

NOTE: Optional packages shown on the above units.

These guidelines are recommended for the proper installation of Oasis products. A careful review of these procedures (and any referenced publications) before starting is important in avoiding an improper assembly and/or installation.

NOTE: All illustrations in this publication are typical, and may appear different than the actual product. Optional items may also be shown that were not ordered on the product being installed.

Special Notes to Installer

- ◆ It is the sole responsibility of the installer to determine the requirements necessary for compliance with all installation code requirements!
- ◆ All paperwork packaged with the product should be saved and presented to the home owner upon completion of the installation!
- ◆ All published product dimensions are for reference only. Any critical dimensions required for installation should be taken directly from the product being installed!
- ◆ Any independent modifications made to the product (or any options / accessories supplied) beyond those required for normal installation can void all warranties! (Refer to warranties for further information)

INSPECTION GUIDELINES

Carefully check the unit upon receipt. Notify your supplier immediately if any questions or problems are encountered during this process.

DO NOT INSTALL PRODUCT WITHOUT FIRST ADDRESSING QUESTIONS WHICH ARISE DURING THE INSPECTION!

Basic Module Check

- Check unit drain position for match to bathroom drain location.
- Check unit for surface damage.
- Check wall section(s) and base for color match.
- Check unit color for coordination to other bathroom fixtures.

INSTALLATION SITE FRAMING

The recommended framing and dimensional requirements shown are for a traditional application and may vary, based on site requirements.

The dimensions shown in the dimensional diagram(s) are from the surfaces where the unit will be attached (1a, b, & c). This surface can be bare studding, dry wall or other suitable under layment material. It is important that the floor and all framing be square, plumb and level. Framing must be

done using accepted materials and construction techniques in accordance with all applicable codes for the site.

NOTE: Any pre-constructed wall(s) may require modification or additional framing to allow for factory applied pipes and/or fittings which may protrude from the body of the unit.

INSTALLATION PROCEDURE

NOTE: 'Wet-set' is not required to support the floor under an Oasis product due to the encapsulated Balsa wood construction.

The VURSA kd, multi-piece system is designed as a front side installation procedure, with four (4) individual sections locking securely together. Factory-installed pegs have been positioned on the top ledge of the

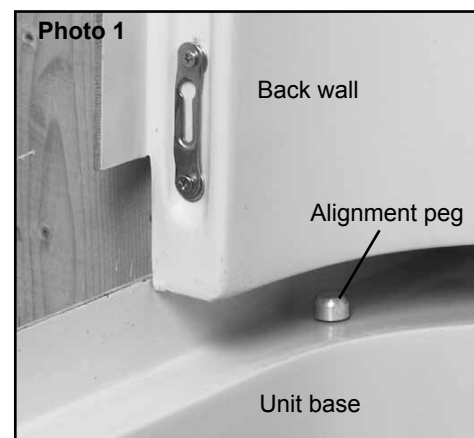

Illustrations 1a - Unit Dimension & Alcove Framing Guidelines (dimensional tolerance +0 / -1/8")

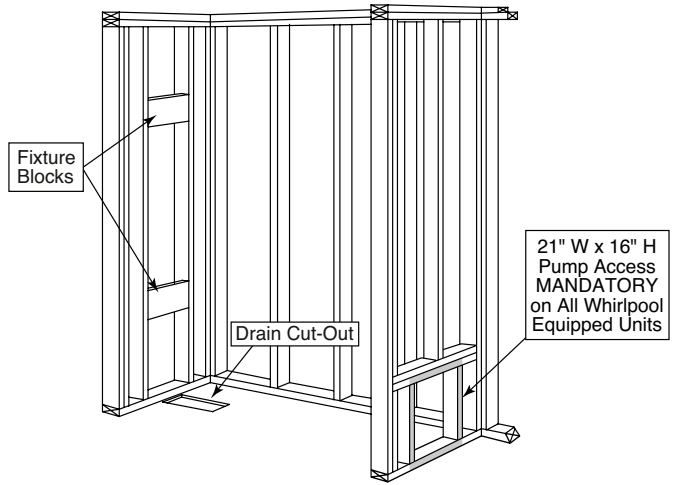
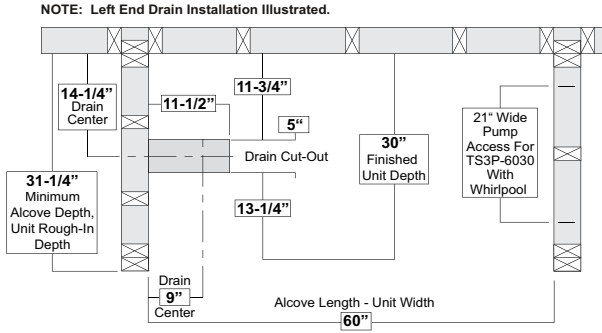

SH4P-6030R-LS (illustr.)

	Std Unit	ABF Unit
A	76-1/4"	78-1/4"
B	75"	77"
C	4"	6"
D	1"	3"
E	-	-
F	22"	24"

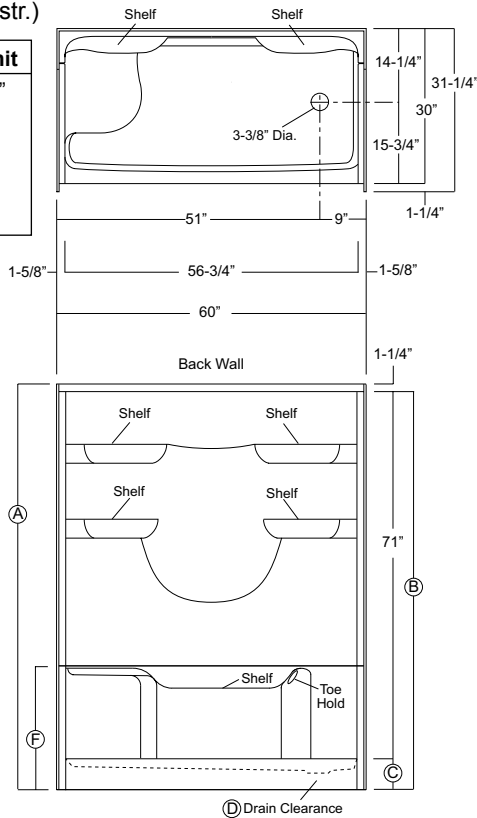

TS4P-6030R (illustr.)

	Std Unit	ABF Unit
A	77"	78-1/4"
B	75-3/4"	77"
C	16"	17-1/4"
D	1-3/4"	3"
E	13-3/4"	15"
F	22-3/4"	24"

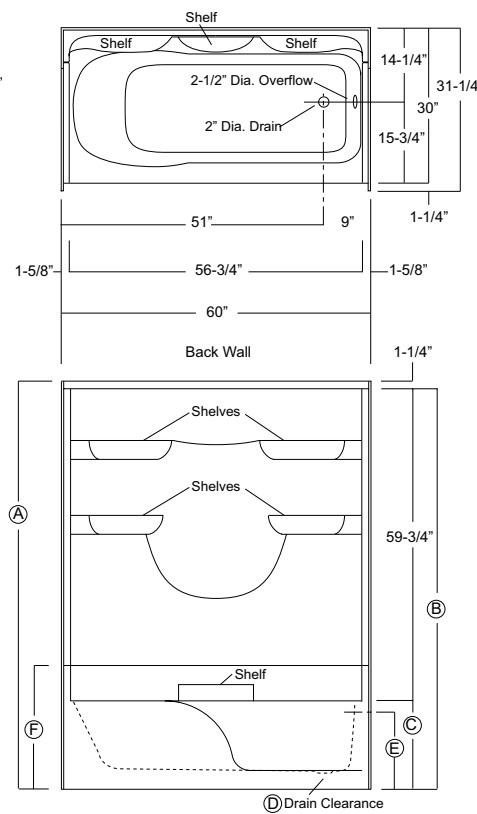

base and bottom edges of the wall panels along with slot and peg fasteners on each of the side wall face sections (photos 1 & 2). Holes on the underside of the wall sections contain a unique connector which locks to the pegs. The connection process provides an audible "CLICK" when each peg and insert are mated, resulting in compression along the bottom seam.

WARNING: Alcove framing members that tilt, angle or protrude into the installation area can compromise proper alignment of the sections. Use of additional shims behind the attachment flanges may be required to ensure the base component remains



square, and plumb in the framed area. Caution must be used to avoid distorting the unit shape, which can compromise proper alignment of the VURSA kd sections.

1. Position the base component in the framed area. Before attaching the base section to the framing, a series of details must be checked (photo 3).

- Confirm the lower apron/dam is resting flush on the floor.
- Confirm the base component is level along the back, the front and ends.
- Confirm the base component is positioned square in the framed area.

Illustrations 1b - Unit Dimension & Alcove Framing Guidelines (dimensional tolerance +0 / -1/8")

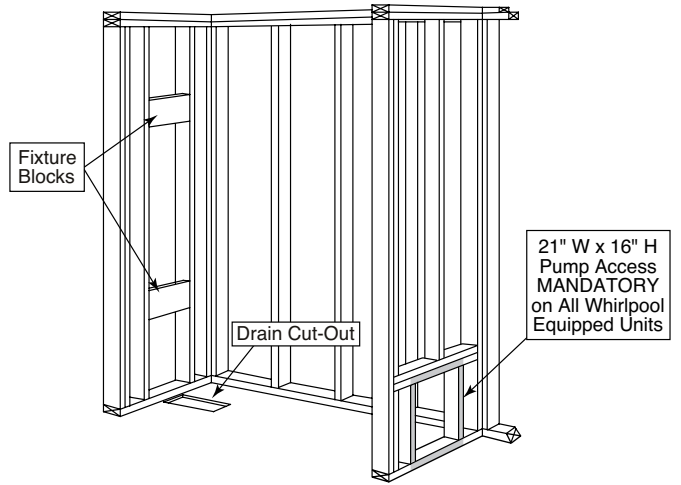
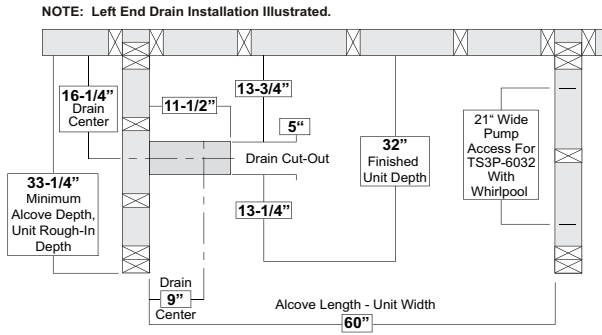

SH4P-6032R-LS (illustr.)

	Std Unit	ABF Unit
A	76-1/4"	78-1/4"
B	75"	77"
C	4"	6"
D	1"	3"
E	-	-
F	22"	24"

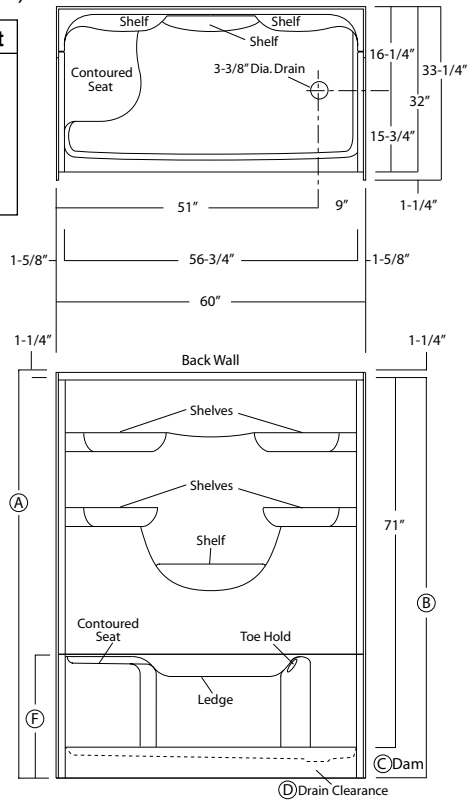

TS4P-6032R (illustr.)

	Base Unit	ABF Unit
A	77"	78-1/4"
B	75-3/4"	77"
C	16"	17-1/4"
D	1-3/4"	3"
E	13-3/4"	15"
F	22-3/4"	24"

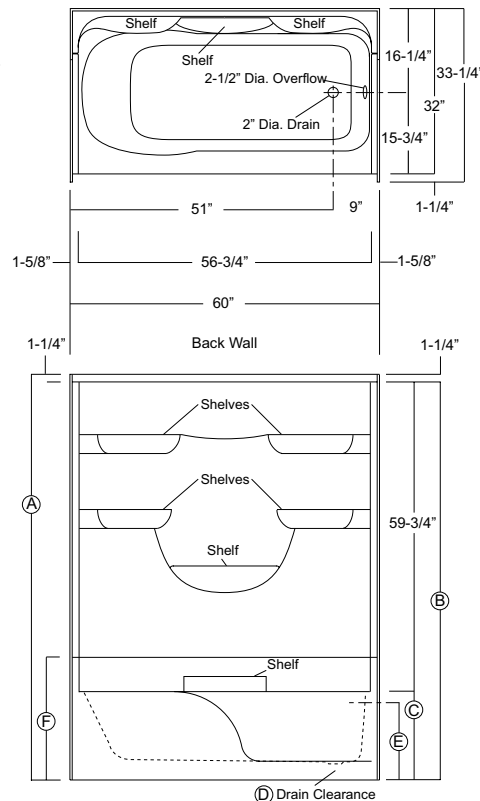

- Confirm the base component is positioned plumb in the framed alcove.
- Confirm the drain hole position.

SPECIAL NOTE:
It may be necessary to shim the base and/or back wall section(s) behind attachment flanges across the entire back wall to obtain square.

THE BASE MUST BE LEVEL, SQUARE AND PLUMB TO INSURE PROPER FIT OF THE UPPER WALL SECTIONS!

NOTE: A dry-fit of the backwall section to the base is essential in eliminating mistakes

or additional labor, later in the installation. Always pre-drill the attachment flanges prior to applying nails or screws.

2. With the base component correctly positioned and level, drill a 1/8" hole through the backwall flanges at each framing member (photo 4). Temporarily attach the flange across the back at several points to secure it in place using 1-1/4" long nails or other appropriate fasteners. Continually check to make sure the base component remains square and plumb within the framed area as it is being secured to ensure proper alignment for the upper sections.

Illustrations 1c - Unit Dimension & Alcove Framing Guidelines (dimensional tolerance +0 / -1/8")

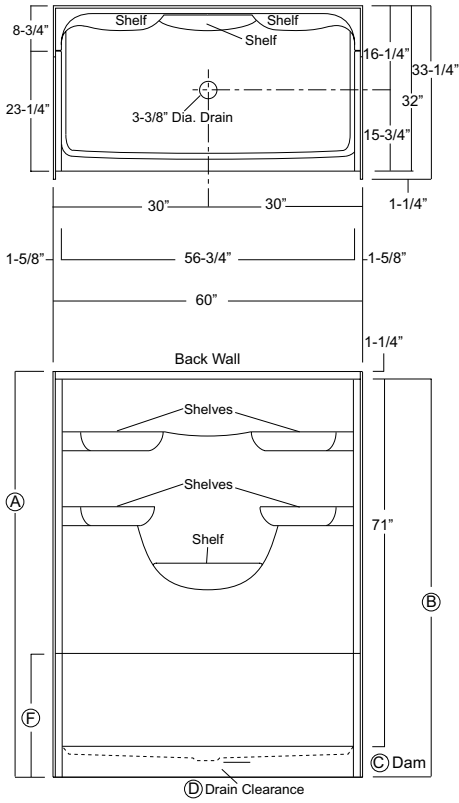

SH4P-6032 ABF (illustrated)

	Std Unit	ABF Unit
A	76-1/4"	78-1/4"
B	75"	77"
C	4"	6"
D	1"	3"
E	-	-
F	22"	24"

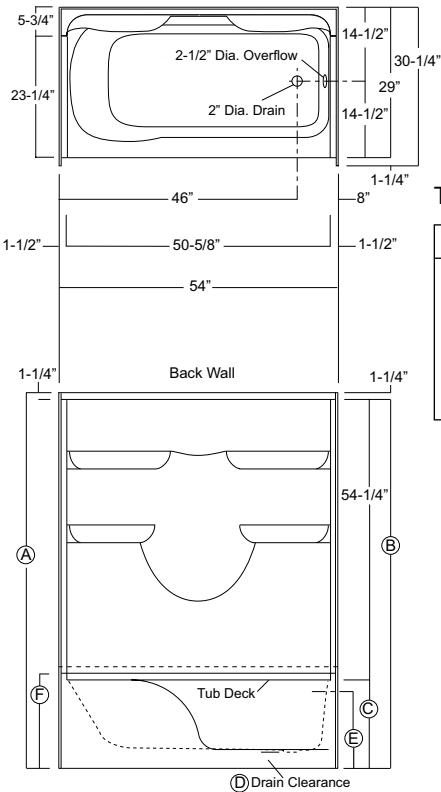
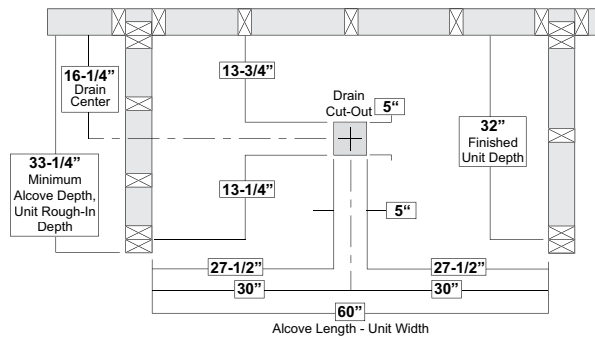
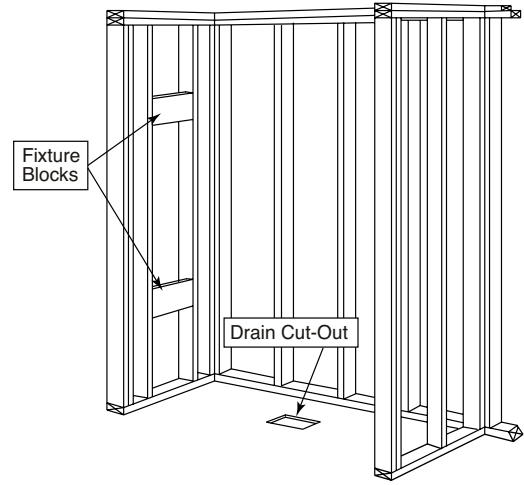

TS4P-5429R ABF (illustr.)

	Std Unit	ABF Unit
A	71-1/2"	72-3/4"
B	70-1/4"	71-1/2"
C	16"	17-1/4"
D	1-3/4"	3"
E	13-3/4"	15"
F	17-1/4"	18-1/2"

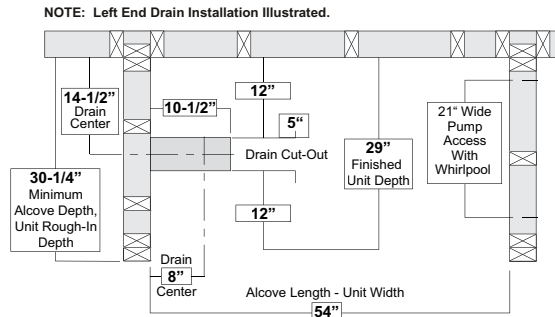
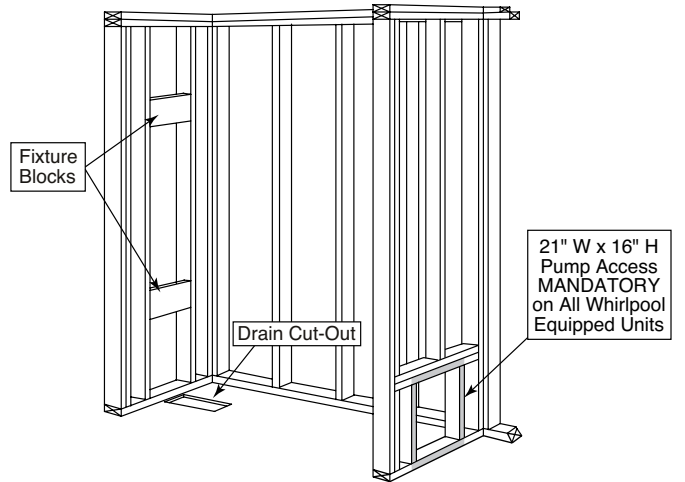

NOTE: Left End Drain Installation Illustrated.



Photo 4

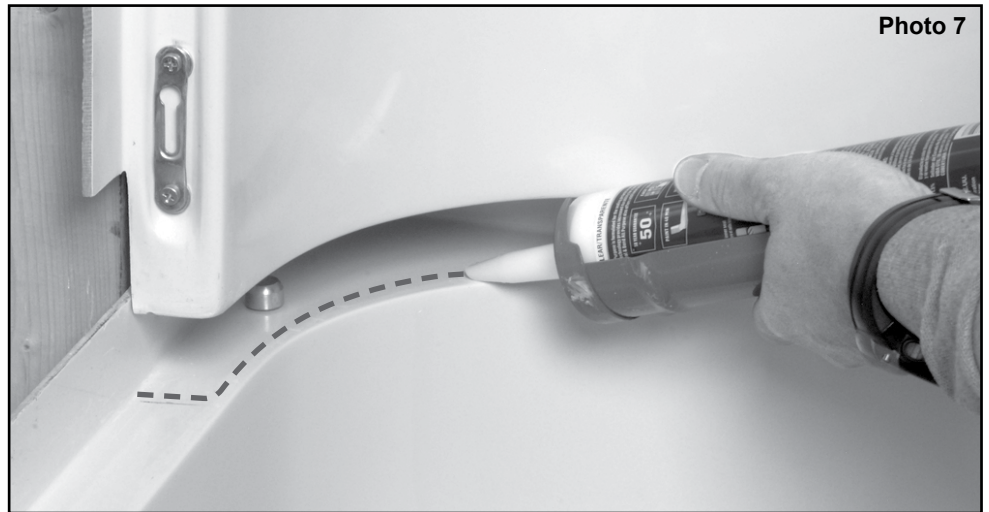

Photo 7



Photo 5

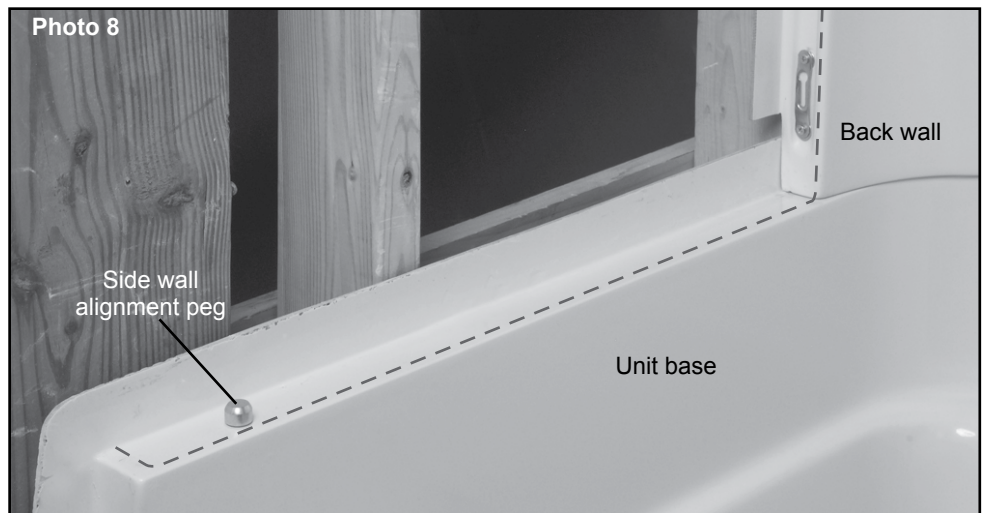

Photo 8

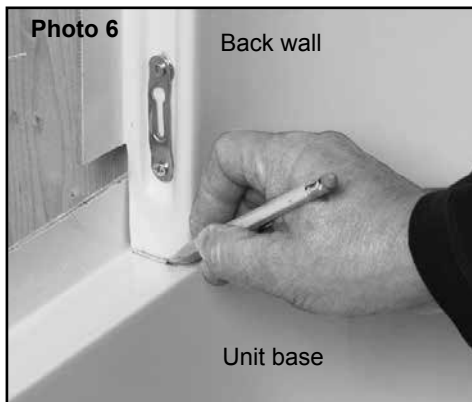

Photo 6

properly positioned, the pegs enter holes along the underside of the back-wall ledge and 'CLICK' in place confirming a positive connection.

Using a framing square, check the backwall to base at both ends for square (photo 5). This should be 90 degrees in order for the side walls to seat properly. If NOT square, shim the back wall at the mounting flange OR add additional shims to the base unit at the rear mounting flange, in order to gain a square edge between the sections.

4. Temporarily secure the back wall to several framing members. Continually check to make sure the horizontal seam remains tight as this section is being attached to the framing.

5. With proper alignment and square confirmed, mark the front edge of the back wall with a pencil (photo 6) and lift the wall off the base and out of the alcove area. Thoroughly clean the mating surfaces on both the base component and the wall sections.



Photo 9

Apply a SMALL continuous bead of sealant, approximately 1/8-inch wide, on the top ledge of the base component surface, beginning at the pencil mark and work along an imaginary line from one side of the back wall to the opposite side (photo 7). NOTE: Oasis recommends a high-quality silicone-based sealant with a mold and mildew resistant content.

NOTE: Usage of a thin shield to protect the unit surface while fastening it to the framing is recommended.

WARNING!
THE BASE COMPONENT FLOOR
SHOULD BE CLEAR OF ALL LOOSE
DEBRIS AND THE SURFACE
PROTECTED BEFORE
STEPPING INSIDE.

3. With the base component securely attached to the framing, dry-fit the back-wall section to confirm proper alignment and identify any required shim or alcove adjustments necessary for the base component. To perform the dry-fit procedure, position the back-wall section above the pegs on the rear of the base component. When

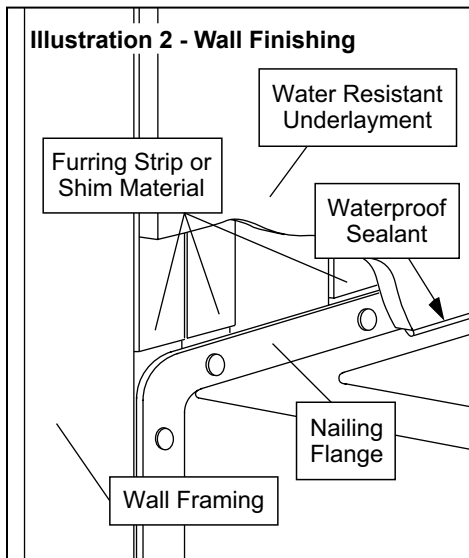

WARNING!

DO NOT APPLY SEALANT ON THE TOP OF ANY PEGS AS IT MAY COMPROMISE THE LOCKING CONNECTION. SILICONE MUST BE APPLIED TO THE INSIDE EDGE OF THE MOUNTING PEGS.

Carefully reposition the back-wall section over the pegs on the base component and listen for the audible 'CLICK' to confirm the connection. Remove any excess silicone from the seam at this time.

6. Attach the flange across the back using 1-1/4" long nails or other appropriate fasteners. Continually check to make sure the horizontal seam remains tight as this section is being attached to the framing.

NOTE: The use of shims behind the attachment flange may be required to ensure proper alignment. Caution must be used to avoid distorting the unit shape, which can affect sidewall alignment.

7. With the back wall securely attached to the framing, double-check to ensure the backwall to base is still square (photo 5).

8. Once square is confirmed, apply a SMALL continuous bead of sealant on the top ledge of the base as well as the vertical back wall edge, beginning at the attachment flange of the first peg, along an imaginary line from front the peg to the vertical face of the back wall and up the vertical edge (photo 8). At the front corners, extend the bead at the base of the front peg to the front and back to the face of the attachment flange..

9. Begin by positioning the three (3) shoulder pins along the wall edge into the adjacent slotted brackets on the backwall vertical edge. Once inserted, push the side

wall down until it contacts the base unit, ensuring that the base peg enters the hole on the bottom of the side wall.

10. Using a 4-foot level, confirm the side walls are plumb to the base (pic 9). This is important for the installation of a shower enclosure. Shims may be required behind the sidewall attachment flanges to obtain plumb. Once the wall is plumbed, drill a 1/8" hole through the mounting flanges at each framing member and every 6-8 inches along the vertical flange and secure using 1-1/4" long nails or other appropriate fasteners. Continually check to make sure the bottom seams remain tight as this section is being attached to the framing. Adjust or add any shims as needed to ensure each section is square and tight.

NOTE: The use of shims behind the attachment flanges may be required to ensure proper alignment. Caution must be used to avoid distorting the unit shape, which can affect sidewall alignment.

Water Supply and Drain Connections

Refer to, and follow, the assembly and installation instructions provided with the supply valves and drain system. Carefully check all connections for leaks.

Finishing Guidelines

Filler strips or filler material may be required over the framing to ensure the underlayment mounts flush over the flanges. A water resistant underlayment is recommended surrounding the unit. Stop the underlayment 1/16 to 1/8-inch from the unit surface, and fill the space with a continuous bead of water resistant sealant (illust. 2).

Use care when fastening the underlayment near the unit surface to avoid damage. Seal the underlayment seams and edges, as required, and install the finish material to specifications.

Through routine use, the unit surface can collect residues from soap, bath additives and natural body oils. Additional deposits can also collect from minerals or particles found in the water. After each use, wipe the excess water from the unit. This practice will reduce the buildup of deposits and help maintain the natural unit lustre.

Following a thorough surface cleaning, an application of quality automotive wax will help reduce major accumulations. The actual schedule for cleaning and waxing will depend on unit usage and water quality.

WARNING!
NEVER APPLY WAX TO THE UNIT FLOOR!

- ◆ Routine Cleaning: Mild, non-abrasive cleaner specifically formulated for gelcoat and acrylic surfaces recommended. (Rinse surface thoroughly)
- ◆ Heavy Soap Deposits: Liquid ammonia household cleaner, applied full strength. (Rinse surface thoroughly)
- ◆ Stubborn Stains: Liquid household cleaner or hydrogen peroxide applied full strength. Place a saturated clean rag directly on stain and let stand several hours. (Rinse surface thoroughly)
- ◆ Hard Water Scales: Liquid scale remover or white vinegar, applied full strength. (Rinse surface thoroughly)
- ◆ Mold/Mildew: Liquid mildew remover or baking soda and water paste. (Apply paste and allow to fizz several minutes.) (Rinse surface thoroughly)
- ◆ Construction Adhesive: Soften adhesive with a hand held hair dryer and peel off adhesive. (Caution is advised when using any electrical device near water.)

For adhesive residue, apply rubbing alcohol or nail polish remover, full strength. (Rinse surface thoroughly)

UNIT SURFACE CARE

WARNING!
NEVER USE ABRASIVE MATERIALS, OR ABRASIVE CLEANERS ON THE UNIT SURFACE!

EXTREME CAUTION is urged regarding the use of any cleaner, acid or solvent on the unit surface.

READ AND FOLLOW PACKAGE INSTRUCTIONS FOR ALL PURCHASED CLEANING PRODUCTS!

WARNING!
BATH MATS AND OTHER ITEMS HELD IN PLACE USING SUCTIONS MUST BE REMOVED FROM THE UNIT SURFACE AFTER EACH USE.

OVER AN EXTENDED PERIOD, FAILURE TO REMOVE SUCTION ATTACHED ITEMS WILL DAMAGE THE UNIT SURFACE.



Oasis Lifestyle Product Assurance Program

Bathing and Shower Unit Structure & Surface Finish Limited Warranty

Oasis Lifestyle provides a performance assurance program for unit structural integrity and surface finish covering a five (5) year period from the date-of-purchase on GELCOAT, and covering a ten (10) year period from the date-of-purchase on VACUUM FORMED ACRYLIC product, for the original purchaser and subsequent consumer. This Oasis limited warranty program addresses specific defects in the product, and the workmanship associated with the manufacture of the Oasis bathing and shower product. The specific defects covered must result in a significantly altered appearance and/or affect the intended performance standards for the product under normal residential use.

Hydro-Massage Systems (water recirculation & air), Option & Accessories Limited Warranty

Oasis Lifestyle provides a performance assurance program for their hydro-massage systems (herein called 'system'), and their options and accessories covering a two (2) year period from the date-of-purchase for the original purchaser and subsequent consumer. This Oasis limited warranty program addresses specific defects in the system components, and the workmanship associated with the assembly of the systems, along with offered options and accessories installed by Oasis, on an Oasis unit. The specific defects covered must result in a significantly altered appearance and/or affect the intended performance standards for the system, the option and/or the accessory.

During the coverage period, Oasis will, at its discretion (following a verification by an authorized Oasis representative), either provide service or supply a replacement product without charge, but excluding any cost associated with the transportation, removal of and/or reinstallation of the unit (module). Failure to allow requested inspection by an authorized Oasis representative, and/or failure to provide adequate accessibility for an authorized inspection, and/or service performed prior to documented authorization from Oasis Lifestyle, LLC., may delay service, and/or possibly terminate any warranty coverage, and remove any liability to Oasis Lifestyle, LLC.

This 'Product Assurance Program' does not cover service resulting the following:

- a) Improper field installation of the product, system, option, accessory, and/or surrounding structure modifications, and/or utility service connections beyond the recommendations supplied by Oasis and within the scope of applicable codes and ordinances; or
- b) Carelessness, damage, abuse, misuse, negligence, improper care, fire, flood, or acts of God; or
- c) Non-conforming use, including any use beyond those intended for the product, system, option and/or accessory, including failure to follow the Prescribed Care and Maintenance Instructions; or
- d) Any unauthorized alterations or modifications to the product, system, option, accessory and/or the individual parts or components supplied by Oasis.
- e) Any surface and/or component staining, discoloration, component failure and/or build-up caused as a result of water chemistry or water quality at the site.
- f) Service resulting from normal use and wear for the product, system, option and/or accessory.

Repair or the supplying of replacement product and/or components, under this limited warranty program, shall be the exclusive remedy. Oasis Lifestyle, LLC., shall not be liable for any incidental or consequential damages, including damages to the building / structure, the contents, the occupants, or breach of any expressed or implied warranties. Oasis Lifestyle, LLC., does not recognize, nor authorizes any party to provide implied or written warranties regarding a product, system, option and/or accessories fitness for a particular purpose, nor modify the terms of the limited warranty beyond those stated.

Some states do not allow the exclusion or limitation of incidental or consequential damages, or allow limitations on the duration of any implied warranty. Therefore, the above exclusions and/or limitations may not apply.

THIS WARRANTY PROVIDES SPECIFIC LEGAL RIGHTS, WHICH CAN VARY FROM STATE-TO-STATE.

