

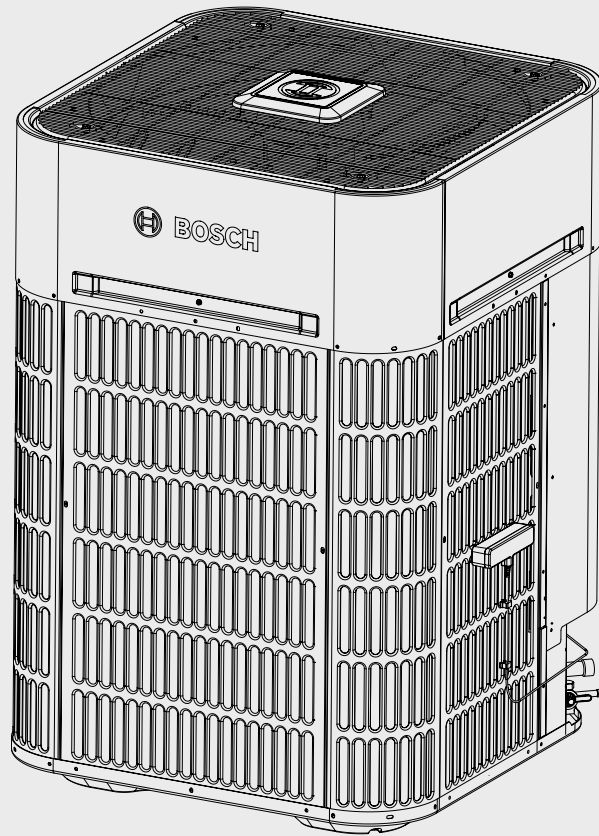

Installation Instructions

# Bosch IDS Heat Pump Ultra Series Condensing Unit

3-5 Ton Capacity | R-454B



BTC 762003305 J / 02.2026





**Table of Contents**

<b>1</b>	<b>Key to Symbols and Safety Instructions</b>	<b>4</b>	<b>14</b>	<b>Electrical - High Voltage</b>	<b>38</b>
1.1	Key to Symbols	4	14.1	High Voltage Power Supply	38
1.2	Explanation of Symbols Displayed on the Unit	4	14.2	High Voltage Disconnect Switch	38
1.3	Safety	4	14.3	High Voltage Ground	38
1.3.1	Gateway Related Warnings	10			
<b>2</b>	<b>Bosch EasyAir Mobile App</b>	<b>11</b>	<b>15</b>	<b>Unit Type Selection</b>	<b>39</b>
<b>3</b>	<b>Unit Location Considerations</b>	<b>11</b>	<b>16</b>	<b>Start Up</b>	<b>39</b>
3.1	Unit Dimensions	11	16.1	System Start Up	39
3.2	Refrigerant Piping Limits	12	16.2	Communication with BCC100/BCC110 (Optional)	41
3.3	Location Restrictions	13			
3.4	Refrigerant Charge and Room Area Limitations	14	<b>17</b>	<b>System Charge Adjustment</b>	<b>42</b>
3.4.1	The Room Area Calculation Requirements	15	17.1	Charging: Weigh-In Method	42
3.4.2	The Allowed Maximum Refrigerant Charge and Required Minimum Room Area	16	17.2	Subcooling Charging And Refrigerant Adjustment In Cooling (Above 50°F Outdoor Temp.)	42
			17.3	Record the Refrigerant Charge Amount	44
<b>4</b>	<b>Unit Preparation</b>	<b>19</b>	<b>18</b>	<b>System Operation and Troubleshooting</b>	<b>45</b>
4.1	Prepare the Unit for Installation	19	18.1	Control Logic Description	45
<b>5</b>	<b>Setting the Unit</b>	<b>19</b>	18.2	Sensors (Thermistors/Pressure Transducer)	45
5.1	Pad Installation	19	18.3	Pressure Equalizer Valve (PEV/SV5)	45
5.2	Mounting Antenna	20	18.4	Defrost Description	45
<b>6</b>	<b>Refrigerant Line Considerations</b>	<b>21</b>	18.5	Compressor Crankcase Heater Description	46
6.1	Refrigerant Line and Service Valve Connection Sizes	21	18.6	Reversing Valve Operation	46
6.2	Required Refrigerant Line Length	21	18.7	Basepan Heater Operation	46
6.3	Refrigerant Line Insulation	21	18.8	Protection Functions	46
6.4	Reuse Existing Refrigerant Lines	21	18.9	Fault Code Table	47
<b>7</b>	<b>Refrigerant Line Routing</b>	<b>21</b>	18.10	System Protection Status Codes	48
7.1	Precautions	21	18.11	Parameter Check Point Table	49
<b>8</b>	<b>Refrigerant Line Connection</b>	<b>23</b>	18.12	Control Board Overviews	50
<b>9</b>	<b>Refrigerant Line Brazing or Crimping</b>	<b>24</b>	18.13	Error Code Troubleshooting	51
9.1	Braze the Refrigerant Lines	24	18.13.1	Online Help Resources	67
9.2	Crimping the Refrigerant Lines	25	18.14	Temperature and Resistance Relationship Tables (for Sensors)	67
<b>10</b>	<b>Refrigerant Line Leak Check</b>	<b>26</b>	18.15	Temperature and Resistance Relationship Tables (for T5 Sensors)	68
10.1	Check For Leaks	26	<b>19</b>	<b>Wiring Diagram</b>	<b>69</b>
<b>11</b>	<b>Evacuation</b>	<b>26</b>	<b>20</b>	<b>IDS Ultra Gateway Functionality</b>	<b>70</b>
11.1	Evacuate the Refrigerant Lines and Indoor Coil	26	<b>21</b>	<b>Care and Maintenance</b>	<b>71</b>
<b>12</b>	<b>Service Valves</b>	<b>27</b>	21.1	Cleaning Precautions	71
12.1	Open the Service Valves	27	21.2	Maintenance – Pre-Season Inspection	71
<b>13</b>	<b>Electrical - Low Voltage</b>	<b>28</b>	<b>22</b>	<b>Disposal</b>	<b>71</b>
13.1	Low Voltage Maximum Wire Length	28			
13.2	Thermostat Wiring	28			
13.2.1	Communicating Set Up	29			

## 1 Key to Symbols and Safety Instructions

### 1.1 Key to Symbols

#### Warnings

In warnings, signal words at the beginning of a warning are used to indicate the type and seriousness of the ensuing risk if measures for minimizing danger are not taken.

The following keywords are defined and can be used in this document:

**DANGER**  
**DANGER** indicates a hazardous situation which, if not avoided, will result in death or serious injury.

**WARNING**  
**WARNING** indicates a hazardous situation which, if not avoided, could result in death or serious injury.

**CAUTION**  
**CAUTION** indicates a hazardous situation which, if not avoided, could result in minor to moderate injury.

**NOTICE**  
**NOTICE** is used to address practices not related to personal injury.

#### Important information

The info symbol indicates important information where there is no risk to people or property.

### 1.2 Explanation of Symbols Displayed on the Unit

Symbol	
	<b>WARNING</b> This symbol shows that this appliance uses a mildly flammable refrigerant. If the refrigerant is leaked and exposed to an external ignition source, there is a risk of fire.
	<b>WARNING</b> This symbol shows that appliance shall be installed, operated and stored in a room with a floor area not less than the minimum room area.
	<b>CAUTION</b> This symbol shows that the operation manual should be read carefully.
	<b>CAUTION</b> This symbol shows that a service personnel should be handling this equipment with reference to the installation manual.
	<b>CAUTION</b> This symbol shows that information is available such as the operating manual or installation manual.
	<b>CAUTION</b> This symbol shows that when addition of charge is required by the manufacturer installation instructions for completing the REFRIGERATING SYSTEM. Recorded the resulting total REFRIGERANT CHARGE for each REFRIGERATING SYSTEM.

Table 1

### 1.3 Safety

#### Please read safety precautions before installation

**WARNING**

#### Electrical hazard 380 Volts DC!

Failure to follow this warning could result in property damage, severe personal injury, or death.

WAIT FIVE (5) MINUTES after disconnecting power prior to touching electrical components as they may hold a dangerous charge of 380 VDC, then verify DC Voltage is less than 42VDC at inverter TEST POINTS P-N.

This document is customer property and is to remain with this unit. Please return to service information pack upon completion of work.

These instructions do not cover all variations in systems or provide for every possible contingency to be met in connection with the installation.

Should further information be desired or should particular problems arise which are not covered sufficiently for the purchaser's purposes, the matter should be referred to your installing dealer or local distributor.



The manufacturer recommends installing only approved matched indoor and outdoor systems. The approved matchups are AHRI rated and indoor units must be equipped with R-454B TXV. Some of the benefits of installing approved matched indoor and outdoor split systems are maximum efficiency, optimum performance and the best overall system reliability.



This document contains a wiring diagram and service information. This is customer property and is to remain with this unit. Please return to service information pack upon completion of work. installation.



**WARNING**

**Personal injury, product damage!**

This information is intended for use by individuals possessing adequate backgrounds of electrical and mechanical experience. Any attempt to repair a central air conditioning product may result in personal injury and/or property damage.



**WARNING**

**Hazardous voltage!**

Failure to follow this warning could result in property damage, severe personal injury, or death.

Disconnect all electric power, including remote disconnects before servicing. Follow proper lockout/tagout procedures to ensure the power cannot be inadvertently energized.



**WARNING**

**Refrigerant oil!**

Any attempt to repair a central air conditioning product may result in property damage, severe personal injury, or death. These units use R-454B refrigerant. Use only R-454B approved service equipment. All R-454B systems with variable speed compressors use a POE oil (VG75 or equivalent) that readily absorbs moisture from the atmosphere. To limit this 'hygroscopic' action, the system should remain sealed whenever possible. If a system has been open to the atmosphere for more than 4 hours, the compressor oil must be replaced. Never break a vacuum with air and always change the driers when opening the system for component replacement.



**WARNING**

**Hot surface!**

May cause minor to severe burning. Failure to follow this Caution could result in property damage or personal injury.

Do not touch high temperature components such as the compressor.



**WARNING**

**Contains flammable refrigerant!**

Failure to follow proper procedures can result in personal illness or injury or severe equipment damage. System contains oil and refrigerant under high pressure. Recover refrigerant to relieve pressure before opening system. Flammable refrigerant used.



**WARNING**

**Contains lead!**

This product can expose you to chemicals including Lead and Lead components, which are known to the State of California to cause cancer and birth defects or other reproductive harm. For more information go to [www.P65Warnings.ca.gov](http://www.P65Warnings.ca.gov).



**CAUTION**

**Grounding required!**

Failure to inspect or use proper service tools may result in equipment damage or personal injury. Reconnect all grounding devices. All parts of this product that are capable of conducting electrical current are grounded. If grounding wires, screws, straps, clips, nuts, or washers used to complete a path to ground are removed for service, they must be returned to their original position and properly fastened.



**WARNING**

**Service valves!**

Failure to follow this warning will result in abrupt release of system charge and may result in personal injury and/ or property damage. Extreme caution should be exercised when opening the Liquid Line Service valve. Turn valve stem counterclockwise only until the stem contacts the rolled edge.



**WARNING**

**Brazing or crimping required!**

Failure to inspect lines or use proper service tools may result in equipment damage or personal injury. If using existing refrigerant lines, make certain that all joints are re-crimped or brazed, not soldered.

If refrigerant gas leaks during installation, ventilate the area immediately.

Comply with national gas regulations.



**WARNING**

**High current leakage!**

Grounding is required before connecting electrical supply. Failure to follow this warning could result in property damage, severe personal injury, or death.



**WARNING**

**Risk of fire!**

Mildly flammable refrigerant used.

Follow handling instructions carefully in compliance with national and local regulations.



**DANGER**

**Fire, explosion!**

Store in a well ventilated room without continuously operating flames or other potential ignition.



**WARNING**

**Risk of electric shock!**

Can cause injury or death. Disconnect all remote electric power supplies before servicing.

 **WARNING**
**Risk of fire!**

Flammable refrigerant used. To be repaired only by trained service personnel. Do not puncture refrigerant tubing.

Dispose of properly in accordance with federal or local regulations. Flammable refrigerant used.

Flammable refrigerant used. Consult repair manual/owner's guide before attempting to service this product. All safety precautions must be followed.

Auxiliary devices which may be ignition sources shall not be installed in the ductwork, other than auxiliary devices listed for use with the specific appliance. See instructions.

 **WARNING**
**Personal injury!**

This appliance is not intended for use by persons (including children) with reduced physical, sensory or mental capabilities, or persons who lack experience and knowledge, unless they are supervised or have been given instructions concerning the use of the appliance by a person responsible for their safety.

Children should be supervised to ensure that they do not play with the appliance.

Any person who is involved with working on or opening a refrigerant circuit should hold a current valid certificate from an industry-accredited assessment authority, which authorizes their competence to handle refrigerants safely in accordance with an industry recognized assessment credential.

Servicing shall only be performed as recommended by the equipment manufacturer.

Maintenance and repair requiring the assistance of other skilled personnel shall be carried out under the supervision of a person competent in the use of flammable refrigerants.

Prior to beginning work on systems containing flammable refrigerants, safety checks are necessary to minimize the risk of ignition.

 **WARNING**
**Flammable refrigerant!**

Do not use means to accelerate the defrosting process or to clean, other than those recommended by the manufacturer.

The appliance shall be stored in a room that does not have continuously operating ignition sources (for example: open flames, an operating gas appliance or an operating electric heater).

Do not pierce or burn the unit.

Be aware that refrigerants may not contain an odour.

 **WARNING**
**Safe handling of flammable refrigerant!**

Be sure the heat pump is grounded. In order to avoid electric shock, make sure that the unit is grounded and that the earth wire is not connected to a gas or water pipe, lightning conductor or telephone earth wire.

Do not operate the heat pump with wet hands. An electric shock may happen.

Do not operate the heat pump when using a room fumigation such as insecticide. Failure to observe this precaution could cause the chemicals to become deposited in the unit, which could endanger the health of those who are hypersensitive to chemicals.

To avoid oxygen deficiency, ventilate the room sufficiently if equipment with a burner is used together with the heat pump.

Arrange the drain hose to ensure smooth drainage. Incomplete drainage may cause wetting of the building, furniture, etc.

Never touch the internal parts of the controller. Do not remove the front panel. Some parts inside are dangerous to touch, and machine troubles may occur.

Attention is drawn to the fact that additional transportation regulations may exist with respect to equipment containing flammable gas. The maximum number of pieces of equipment or the configuration of the equipment permitted to be transported together will be determined by the applicable transport regulations.

Signs for similar appliances used in a work area are generally addressed by local regulations and give the minimum requirements for the provision of safety and/or health signs for a work location.

Storage package protection should be constructed such a way that mechanical damage to the equipment inside the package will not cause a leak of the REFRIGERANT CHARGE.

The maximum number of pieces of equipment permitted to be stored together will be determined by local regulations.

Do not place appliances which produce open flame in places exposed to the air flow from the unit or under the indoor unit. It may cause incomplete combustion or deformation of the unit due to the heat.

Do not install the heat pump in a location where flammable gas may leak out. If the gas leaks out and stays around the air conditioner, a fire may break out.

 **WARNING**
**Flammable refrigerant!**

The appliance uses R-454B refrigerant.

**NOTICE****Indoor unit required!**

The indoor units must be matched with R-454B TXV. The model of R-454B TXV can be changed according to the system capacity.

**WARNING**
**Personal Injury, flammable refrigerant!**

When repairing the refrigerating system, comply with the following precautions prior to conducting work on the system:

- Work shall be undertaken according to controlled procedures to minimize the risk of the presence of flammable gases or vapors while the work is being performed.
- All maintenance staff and others working in the local area shall be instructed on the nature of work being carried out. Work in confined spaces shall be avoided.
- The area shall be checked with an appropriate refrigerant detector prior to and during work, to ensure the technician is aware of potentially toxic or flammable environment. Ensure that the leak detection equipment being used is suitable for use with all applicable refrigerants, i.e., non-sparking, adequately sealed or intrinsically safe.
- If any hot work is to be conducted on the refrigerating equipment or any associated parts, appropriate fire extinguishing equipment shall be available and easily accessible. Have a dry powder or CO2 fire extinguisher adjacent to the charging area.
- When carrying out work in relation to a refrigerating system that involves exposing any pipe work, no sources of ignition shall be used in such a manner that it may lead to the risk of fire or explosion. All possible ignition sources, including cigarette smoking, should be kept sufficiently far away from the site of installation, repair, or removal and disposal of the unit, during which refrigerant can possibly be released into the surrounding space. Prior to beginning work, the area around the equipment is to be surveyed to make sure that there are no flammable hazards or ignition risks. "No Smoking" signs shall be clearly displayed.

**WARNING**
**Personal Injury, flammable refrigerant!**

Ensure that the area is in the open or that it is adequately ventilated before opening the system or conducting any hot work. A degree of ventilation shall continue during the period that the work is carried out. The ventilation should safely disperse any released refrigerant and preferably expel it externally into the surroundings.

Where electrical components are being changed, they shall be fit according to their purpose and to the correct specification. At all times the manufacturer's maintenance and service guidelines shall be followed. If in doubt, consult the manufacturer's technical department for assistance. The following checks shall be applied to installations using flammable refrigerants:

- The actual refrigerant charge is in accordance with the room size within which the refrigerant containing parts are installed.
- The ventilation machinery and outlets are operating adequately and are not obstructed.
- If an indirect refrigerating circuit is being used, the secondary circuit shall be checked for the presence of refrigerant.
- Equipment marking must remain visible and legible. Markings and signs that are illegible shall be corrected.

**WARNING**
**Personal Injury, flammable refrigerant!**

Refrigerating pipe or components are installed in a position where they are unlikely to be exposed to any substances which may corrode refrigerant containing components, unless the components are constructed of materials that are inherently resistant to corrosion or are suitably protected against corrosion.

Repair and maintenance of electrical components shall include initial safety checks and component inspection procedures. If a fault exists that could compromise safety, then no electrical supply shall be connected to the circuit until the fault has been dealt with.

- That capacitors are discharged: this shall be done in a safe manner to avoid the possibility of sparking.
- That no live electrical components and wiring are exposed while charging, recovering or purging the system.
- That there is continuity of grounding.

**WARNING**
**Flammable refrigerant!**

Sealed electrical components shall be replaced.

Intrinsically safe components must be replaced.

Check that cabling will not be subject to wear, corrosion, excessive pressure, vibration, sharp edges or any other adverse environmental effects. The check shall also take into account the effects of aging or continual vibration from sources such as compressors or fans.

Under no circumstances shall potential sources of ignition be used while searching for or detection of refrigerant leaks. A halide torch (or any other detector using a naked flame) shall not be used.

Electronic leak detectors may be used to detect refrigerant leaks but, in the case of flammable refrigerants, the sensitivity may not be adequate, or may need re-calibration. (Detection equipment shall be calibrated in a refrigerant-free area.) Ensure that the detector is not a potential source of ignition and is suitable for the refrigerant used. Leak detection equipment shall be set at a percentage of the LFL of the refrigerant and shall be calibrated for the refrigerant employed, and the appropriate percentage of gas (25 % maximum) is confirmed. If a leak is suspected, all naked flames shall be removed/extinguished.

If refrigerant leakage is found, brazing or crimping is required, and all refrigerants should be recovered from the system or isolated from the leakage point.

Leak detection fluids are also suitable for use with most refrigerants but the use of detergents containing chlorine shall be avoided as the chlorine may react with the refrigerant and corrode the copper pipe-work.

Examples of leak detection fluids are:

- bubble method,
- fluorescent method agents.

 **WARNING**
**Flammable refrigerant!**

When breaking into the refrigerant circuit to make repairs or for any other purpose conventional procedures shall be used. However, for flammable refrigerants it is important that best practice be followed, since flammability is a consideration. The following procedure shall be adhered to:

- safely remove refrigerant following local and national regulations.
- evacuate.
- purge the circuit with inert gas
- continuously flush or purge with inert gas when using flame to open circuit, and.
- open the circuit.

The refrigerant charge shall be recovered into the correct recovery cylinders if venting is not allowed by local and national codes. For appliances containing flammable refrigerants, the system shall be purged with oxygen-free nitrogen to render the appliance safe for flammable refrigerants. This process might need to be repeated several times. Compressed air or oxygen shall not be used for purging refrigerant systems.

For appliances containing flammable refrigerants, refrigerants purging shall be achieved by breaking the vacuum in the system with oxygen-free nitrogen and continuing to fill until the working pressure is achieved, then venting to atmosphere, and finally pulling down to a vacuum. This process shall be repeated until no refrigerant is within the system. When the final oxygen-free nitrogen charge is used, the system shall be vented down to atmospheric pressure to enable work to take place.

The outlet for the vacuum pump shall not be close to any potential ignition sources, and ventilation shall be available.

Ensure that contamination of different refrigerants does not occur when using charging equipment. Hoses or lines shall be as short as possible to minimize the amount of refrigerant they contain.

Cylinders shall be kept upright. Ensure that the refrigeration system is grounded prior to charging the system with refrigerant.

If not already labeled, Label the system when charging is complete.

Take extreme care not to overfill the refrigeration system.

 **WARNING**
**Flammable refrigerant!**

Prior to recharging the system, it shall be pressure-tested with the appropriate purging gas. The system shall be leak-tested on completion of charging but prior to commissioning. A follow up leak test shall be carried out prior to leaving the site.

Before carrying out this procedure, it is essential that the technician is completely familiar with the equipment and all its detail. It is recommended that all refrigerants are recovered safely. Prior to the task being carried out, an oil and refrigerant sample shall be taken in case analysis is required prior to re-use of reclaimed refrigerant. It is essential that electrical power is available before the task is commenced.

- a. Become familiar with the equipment and its operation.
- b. Isolate system electrically.
- c. Before attempting the procedure ensure that:
  - mechanical handling equipment is available, if required, for handling refrigerant cylinders.
  - all personal protective equipment is available and being used correctly.
  - the recovery process is supervised at all times by a competent person.
  - recovery equipment and cylinders conform to the appropriate standards.
- d. Pump down refrigerant system, if possible.
- e. If vacuuming is not possible, make an opening so that refrigerant can be removed from various parts of the system.
- f. Make sure that the cylinder is situated on the scales before recovery takes place.
- g. Start the recovery machine and operate it in accordance with the manufacturer's instructions.
- h. Do not overfill cylinders with more than 80% volume liquid charge.
- i. Do not exceed the maximum working pressure of the cylinder, even temporarily.
- j. When the cylinders have been filled correctly and the process has been completed, make sure that the cylinders and the equipment are removed from site promptly and all isolation valves on the equipment are closed off.
- k. Recovered refrigerant shall not be charged into another refrigeration system unless it has been cleaned and checked.

Equipment shall be labeled stating that it has been de-commissioned and emptied of refrigerant. The label shall be dated and signed. Ensure that there are labels on the equipment stating the equipment contains flammable refrigerant.

When removing refrigerant from a system, either for servicing or decommissioning, it is recommended that all refrigerants are removed safely.

When transferring refrigerant into cylinders, ensure that only appropriate refrigerant recovery cylinders are employed. Ensure that the correct number of cylinders for holding the total system charge is available. All cylinders to be used are designated for the recovered refrigerant and labelled for that refrigerant (i.e. special cylinders for the recovery of refrigerant). Cylinders shall be complete with pressure-relief valve and associated shut-off valves in good working order. Empty recovery cylinders are evacuated and, if possible, cooled before recovery occurs.

**WARNING****Flammable refrigerant!**

The recovery equipment shall be in good working order with a set of instructions concerning the equipment that is at hand and shall be suitable for the recovery of the flammable refrigerant. If in doubt, the manufacturer should be consulted. In addition, a set of calibrated weighing scales shall be available and in good working order. Hoses shall be complete with leak-free disconnect couplings and in good condition.

The recovered refrigerant shall be processed according to local legislation in the correct recovery cylinder, and the relevant waste transfer note arranged. Do not mix refrigerants in recovery units and especially not in cylinders.

If compressors or compressor oils are to be removed, ensure that they have been evacuated to an acceptable level to make certain that flammable refrigerant does not remain within the lubricant. The compressor body shall not be heated by an open flame or other ignition sources to accelerate this process. When oil is drained from a system, it shall be carried out safely.

Do not use the heat pump for other purposes. In order to avoid any quality deterioration, do not use the unit for the cooling of precision instruments, food, plants, animals or works of art. Before cleaning, be sure to stop the operation, turn the breaker off or unplug the supply cord. Otherwise, electric shock and injury may occur.

To avoid electric shock or fire, make sure that a leak detector is installed. Never touch the air outlet or the horizontal blades while the swing flap is in operation. Fingers may be caught or the unit may break down.

Never put any objects into the air inlet or outlet. Objects touching the fan at high speed can be dangerous. Never inspect or service the unit by yourself. Ask a qualified service person to perform this task.

Do not dispose of this product as unsorted municipal waste. This waste should be collected separately for special treatment. Do not dispose of electrical appliances as unsorted municipal waste. Use separate collection facilities. Contact your local government for information regarding the connection systems available.

If electrical appliances are disposed of in landfills or dumps, hazardous substances can leak into the groundwater and get into the food chain, hazardous to one's health and well-being.

To prevent refrigerant leak, contact your dealer.

When the system is installed and operates in a small room, it is required to maintain the concentration of the refrigerant below the limit, in case a leak occurs. Otherwise, oxygen in the room may be affected, resulting in a serious accident.

The refrigerant in the heat pump is safe and normally does not leak.

If the refrigerant leaks into the room and encounters the fire of a burner, a heater or a cooker, a harmful gas could be released.

Turn off any combustible heating devices, ventilate the room, and contact the dealer where the unit was purchased.

Do not use the heat pump until a service person confirms that the refrigerant leak is repaired.

Keep ventilation openings clear of obstruction.

**WARNING****Product damage, personal injury!**

This outdoor unit must combine the indoor unit with refrigerant leak detection device.

These instructions are exclusively intended for qualified contractors and authorized installers. Work on the refrigerant circuit with mild flammable refrigerant in safety group A2L may only be carried out by authorized heating contractors. These heating contractors must be trained in accordance with UL 60335-2-40, Section HH. The certificate of competence from an industry accredited body is required.

Work on electrical equipment may only be carried out by a qualified electrician.

Before initial commissioning, all safety – related points must be checked by the particular certified heating contractors. The system must be commissioned by the system installer or a qualified person authorized by the installer.

### 1.3.1 Gateway Related Warnings

#### NOTICE

##### FCC compliance!

This equipment has been tested and found to comply with the limits for a Class B digital device, pursuant to Part 15 of the FCC Rules. These limits are designed to provide reasonable protection against harmful interference in a residential installation. This equipment generates uses and can radiate radio frequency energy and, if not installed and used in accordance with the instructions, may cause harmful interference to radio communications. However, there is no guarantee that interference will not occur in a particular installation. If this equipment does cause harmful interference to radio or television reception, which can be determined by turning the equipment off and on, the user is encouraged to try to correct the interference by one or more of the following measures:

- Reorient or relocate the receiving antenna.
- Increase the separation between the equipment and receiver.
- Connect the equipment into an outlet on a circuit different from that to which the receiver is connected.
- Consult the dealer or an experienced radio/TV technician for help.



This device complies with part 15 of the FCC Rules. Operation is subject to the following two conditions: (1) This device may not cause harmful interference, and (2) this device must accept any interference received, including interference that may cause undesired operation.

Changes or modifications not expressly approved by the party responsible for compliance could void the user's authority to operate the equipment.

#### NOTICE

##### ISED compliance!

This device contains licence-exempt transmitter(s)/ receiver(s) that comply with Innovation, Science and Economic Development Canada's licence-exempt RSS(s). Operation is subject to the following two conditions:

1. This device may not cause interference.
2. This device must accept any interference, including interference that may cause undesired operation of the device.



#### WARNING

##### RF exposure!

This equipment complies with FCC/ISED RF radiation exposure limits set forth for an uncontrolled environment. This equipment should be installed and operated with a minimum distance of 8 inches (20 centimeters) between the antenna and your body.

#### NOTICE

##### ISED compliance!

This device contains licence-exempt transmitter(s)/ receiver(s) that comply with Innovation, Science and Economic Development Canada's licence-exempt RSS(s). Operation is subject to the following two conditions:

1. This device may not cause interference.
2. This device must accept any interference, including interference that may cause undesired operation of the device.

#### NOTICE

##### ICES statement!

CAN ICES-3 (B)/NMB-3 (B).

This Class B digital apparatus complies with Canadian ICES-003.

## 2 Bosch EasyAir Mobile App

This Heat Pump has connectivity features and is compliant with AHRI 1380 standard (Demand Response). The connectivity features include remote/on site monitoring and troubleshooting. Download the Bosch EasyAir app on your smartphone and create an account to get started.

1. Download the Bosch EasyAir app on your smartphone by searching for it in Google Play Store (for Android devices) or App Store (for iPhone). Alternatively, you can scan this QR code with your phone's camera:



Figure 1

2. Launch the Bosch EasyAir App, create a profile and go to "Monitoring & Diagnostic" to add the unit and view on-site and remote system data.

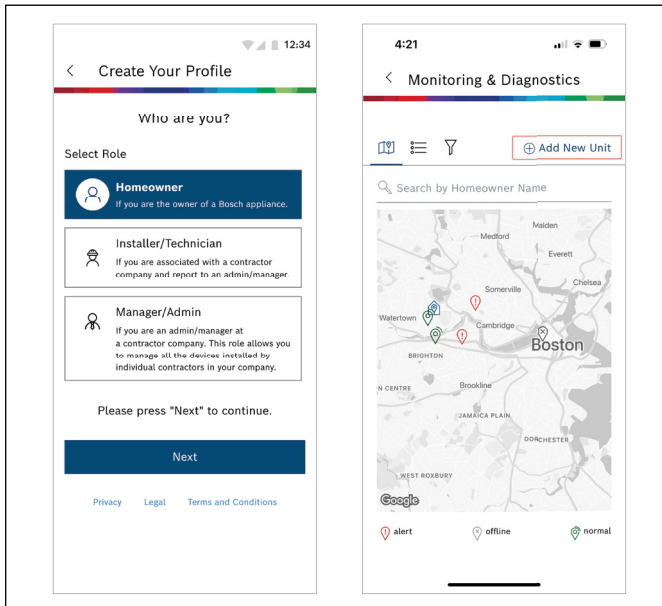

Figure 2



Unit can only be added to EasyAir App and accessed by a Homeowner if the contractor adds to the unit to the App while onsite. Refer to section "16 Start Up" for more information.

## 3 Unit Location Considerations

### 3.1 Unit Dimensions

Model Size	Dimensions (Inches)		
	"H" in [mm]	"W" in [mm]	"L" in [mm]
BOVB19-36	43-5/16 [1100]	29-1/8 [740]	29-1/8 [740]
BOVB19-60			

Table 2

The unit's weight values are on the carton box.

When mounting the outdoor unit on a roof, be sure the roof will support the unit's weight. Properly selected isolation is recommended to prevent sound or vibration transmission to the building structure.

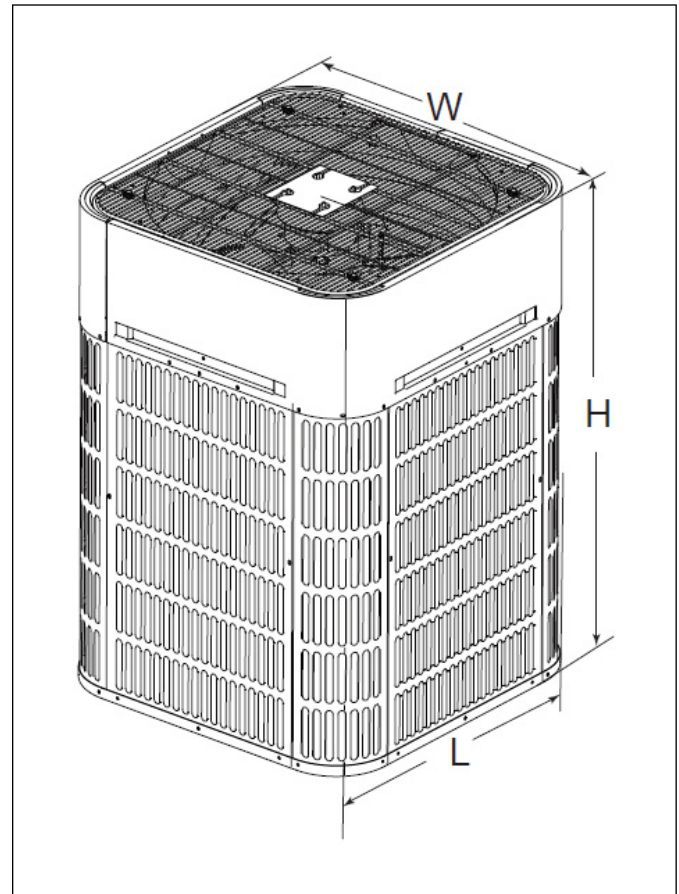

Figure 3

### 3.2 Refrigerant Piping Limits

System Capacity Model	Liquid Line	Suction Line	Total Equivalent Length - Feet					
			25	50	75	100	125	150
			Maximum Vertical Separation - Feet					
3 Ton	3/8*	5/8 Opt.	25	50	50	50	35	25
		3/4 Std.	25	50	50	50	35	25
4 Ton	3/8*	7/8 Std.	25	50	50	40	30	25
		3/4 Opt.	25	50	50	40	30	25
5 Ton	3/8*	7/8 Std.	25	50	50	40	30	25
		3/4 Opt.	25	50	50	40	30	25
		1 1/8 Opt.	25	40	N/A	N/A	N/A	N/A

Table 3 Refrigerant piping limits

\* Standard line size is recommended;  
 N/A: Application not recommended;  
 Refrigerant charge: refer to Sec.17

- Maximum line equivalent length = 150 feet.
- Maximum vertical equivalent length = 50 feet.
- Use only the line diameters indicated in Table 3.
- If the suction linesets are greater than 50 feet, do not use a larger suction line than recommended.

**NOTICE**

**Product damage!**

Failure to follow this notice may result in equipment damage or improper operation.

If ANY refrigerant tubing is buried, provide a 6 in vertical rise at service valve.  
 Refrigerant tubing lengths up to 36 in may be buried without further special consideration. Do not bury lines longer than 36 in

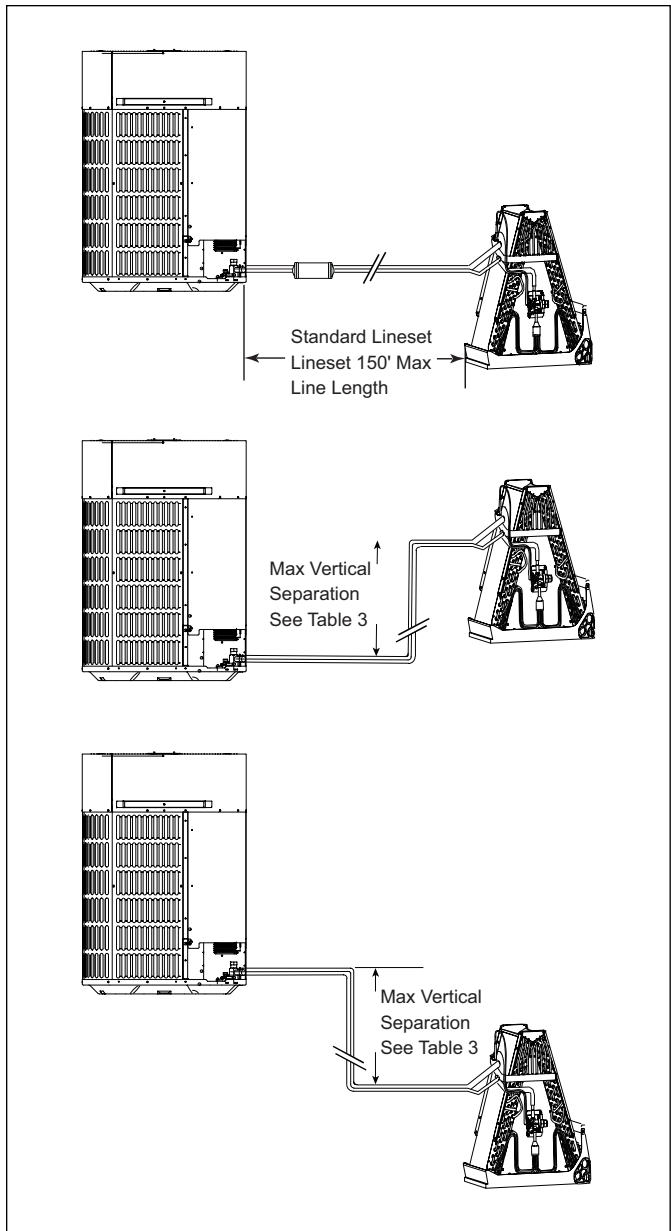

Figure 4 Refrigerant piping limits

**3.3 Location Restrictions**

**WARNING**

**Flammable refrigerant!**

Appliance shall be installed, operated in a room that meets special requirements and has an area limit as shown in “3.4 Refrigerant Charge and Room Area Limitations”

**WARNING**

**Flammable refrigerant!**

The outdoor unit shall be located in a well-ventilated location other than the occupied space, such as in the open air.

For installation of the indoor unit, refer to the corresponding installation and operation manual. If an indoor unit is installed in an unventilated area, the area shall be so constructed that should any refrigerant leak, it will not stagnate so as to create a fire or explosion hazard.

Ensure the top discharge area is unrestricted for at least 60 inches above the unit.

Do not locate outdoor unit near bedrooms since normal operational sounds may be objectionable.

Position unit to allow adequate space for unobstructed airflow, wiring, refrigerant lines, and serviceability.

Allow a minimum of 12 in clearance on one side of control board access panel to a wall and a minimum of 24 in on the adjacent side of control board access panel.

Maintain a distance of 24 in between units.

Position unit where water, snow, or ice from roof or overhang cannot fall directly on unit.

Only use this unit in well-ventilated spaces and ensure that there are no obstructions that could impede the airflow into and out of the unit. Do not use this unit in the following locations:

- Locations with mineral oil.
- Locations with saline atmospheres, such as seaside locations.
- Locations with sulphurous atmospheres, such as near natural hot springs.
- Where high voltage electricity is present, such as in certain industrial locations.
- On vehicles or vessels, such as trucks or ferry boats.
- Where exposure to oily or very humid air may occur, such as kitchens.
- In proximity to sources of electromagnetic radiation, such as high-frequency transmitters or other high strength radiation devices.

See Figure 5 and Figure 6.

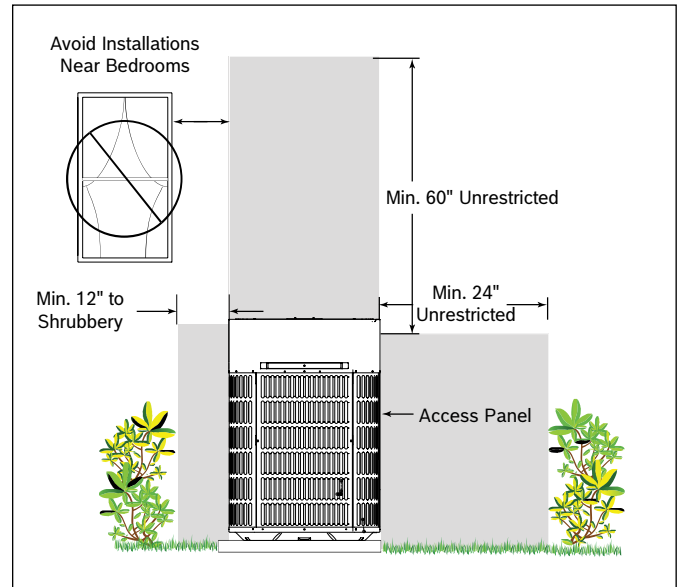

Figure 5

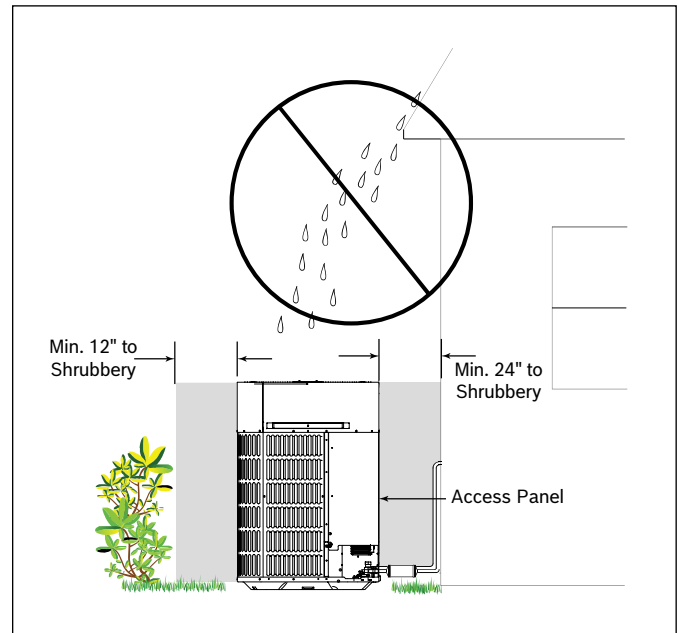

Figure 6



Precautions must be taken for units being installed in areas where snow accumulation and prolonged below-freezing temperatures occur.

- Units should be elevated 3-12 inches above the pad or rooftop, depending on local weather. This additional height will allow drainage of snow and ice melted during defrost cycle prior to its refreezing. Ensure that drain holes in unit base pan are not obstructed, which could prevent the drainage of defrost water (Figure 7).
- If possible, avoid locations that are prone to snow drifts. If not possible, a snow drift barrier should be installed around the unit to prevent a build-up of snow on the sides of the unit.



Using a 5-point support system with snow legs is an effective way to distribute the weight of the outdoor unit, specifically supporting the compressor within it. This setup helps to prevent stress on individual points and ensures that the weight is evenly distributed, reducing the risk of damage or instability, especially in snowy conditions. By providing multiple points of contact, you're enhancing the unit's stability and longevity, which is crucial for its efficient operation over time.

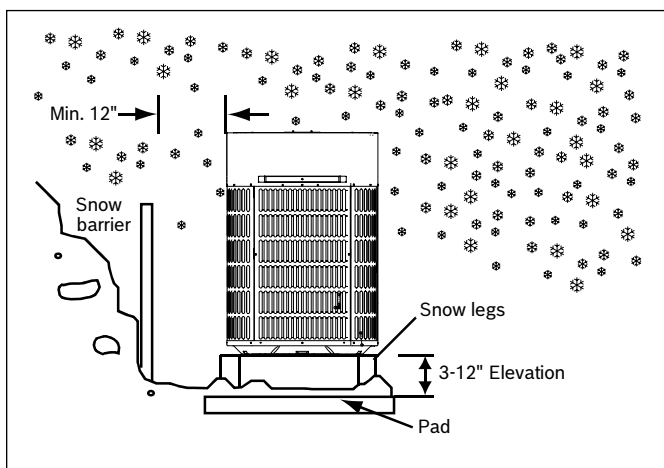

Figure 7

### Corrosive Environment

Exposure to a corrosive environment may shorten the life of the equipment, corrode metal parts, and/or negatively affect unit performance. Corrosive elements include, but are not limited to: sodium chloride, sodium hydroxide, sodium sulfate, and other compounds commonly found in ocean water, sulfur, chlorine, fluorine, fertilizers, and various chemical contaminants from industry/manufacturing plants. If installed in areas which may be exposed to corrosive environments, special attention should be given to the equipment placement and maintenance.

- Lawn sprinklers/hoses/waste water should not spray directly on the unit cabinet for prolonged periods of time.
- In coastal areas: locate the unit on the side of the building away from the waterfront.
- Fencing or shrubbery may provide some shielding protection to the unit, however minimum unit clearances must still be maintained.
- Approximately every three months, wash the outdoor coil and any exposed cabinet surfaces with clean water.

### 3.4 Refrigerant Charge and Room Area Limitations

In UL/CSA 60335-2-40, R-454B refrigerant is classified as class A2L, which is mildly flammable. Therefore, R-454B refrigerant is suitable for systems needing additional refrigerant charge and which will limit the area of the rooms being served by the system.

Similarly, the total amount of refrigerant in the system shall be less than or equal to the allowable maximum refrigerant charge. The allowable maximum refrigerant charge depends on the area of the rooms being served by the system.

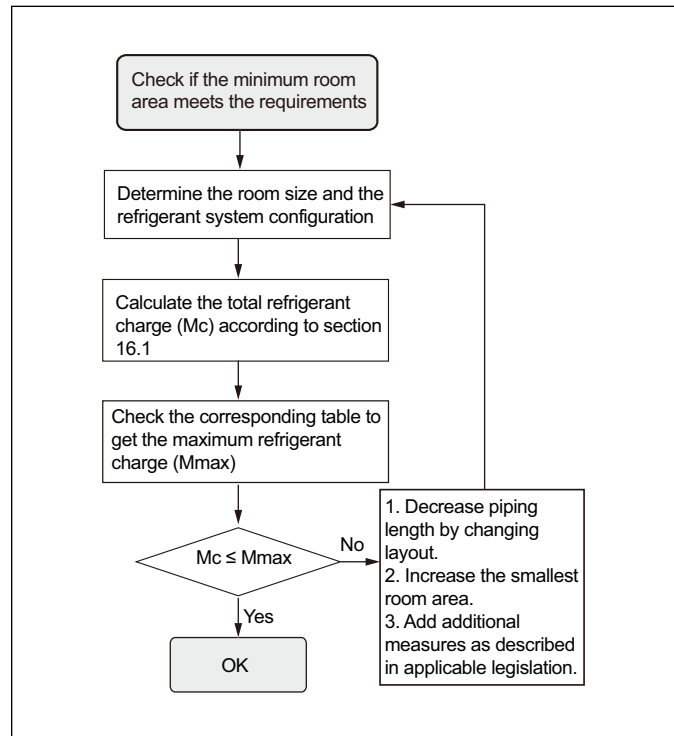

Figure 8



The terms in this section are explained as follows:

- $M_c$ : The actual refrigerant charge in the system.
- $A$ : the actual room area where the appliance is installed.
- $A_{min}$ : The required minimum room area.
- $M_{max}$ : The allowable maximum refrigerant charge in a room.
- $Q_{min}$ : The minimum circulation airflow.
- $A_{nvmmin}$ : The minimum opening area for connected rooms.
- $T_{Amin}$ : The total area of the conditioned space (For appliances serving one or more rooms with an air duct system).
- $T_A$ : The total area of the conditioned space connected by air ducts.

**3.4.1 The Room Area Calculation Requirements**

**CAUTION**

**Flammable refrigerant!**

The space considered shall be any space which contains refrigerant-containing parts or into which refrigerant could be released.

The room area (A) of the smallest, enclosed, occupied space shall be used in the determination of the refrigerant quantity limits.

For determination of room area (A) when used to calculate the refrigerant charge limit, the following shall apply.

The room area (A) shall be defined as the room area enclosed by the projection to the base of the walls, partitions and doors of the space in which the appliance is installed.

Spaces connected by only drop ceilings, ductwork, or similar connections shall not be considered a single space.

Units mounted higher than 70-55/64 inches and spaces divided by partition walls that are no higher than 62-63/64 inches shall be considered a single space. Rooms on the same floor and connected by an open passageway between the spaces can be considered a single room when determining compliance to  $A_{min}$ , if the passageway complies with all of the following.

1. It is a permanent opening.
2. It extends to the floor.
3. It is intended for people to walk through.

The area of the connected rooms, on the same floor, connected by permanent opening in the walls and/or doors between occupied spaces, including gaps between the wall and the floor, can be considered a single room when determining compliance to  $A_{min}$ , provided all of the following conditions are met as shown in Figure 8.

**Low level opening:**

1. The opening shall not be less than  $An_{vmin}$  in Table 4.
2. The area of any openings above 11-13/16 inches from the floor shall not be considered in determining compliance with  $An_{vmin}$ .
3. At least 50% of the opening area of  $An_{vmin}$  shall be below 7-7/8 inches from the floor.
4. The bottom of the opening is not more than 3-15/16 inches from the floor.
5. The opening is a permanent opening that cannot be closed.
6. For openings extending to the floor the height shall not be less than 25/32 inches above the surface of the floor covering.

**High level opening:**

1. The opening shall not be less than 50% of  $An_{vmin}$  in Table 4.
2. The opening is a permanent opening that cannot be closed.
3. The opening shall be at least 59 inches above the floor.
4. The height of the opening is not less than 25/32 inches.

**Room size requirement:**

1. The room into which refrigerant can leak, plus the connected adjacent room(s) shall have a total area not less than  $A_{min}$ .  $A_{min}$  is shown in Table 6 to Table 8.
2. The room area in which the unit is installed shall be not less than 20%  $A_{min}$ .  $A_{min}$  is shown in Table 6 to Table 8.



The requirement for the second opening can be met by drop ceilings, ventilation ducts, or similar arrangements that provide an airflow path between the connected rooms.

The minimum opening for natural ventilation ( $An_{vmin}$ ) in connected rooms is related to the room area (A), the actual refrigerant charge of refrigerant in the system ( $m_c$ ), and the allowable MAXIMUM REFRIGERANT CHARGE in the system ( $m_{max}$ ).  $An_{vmin}$  can be determined according to Table 4.

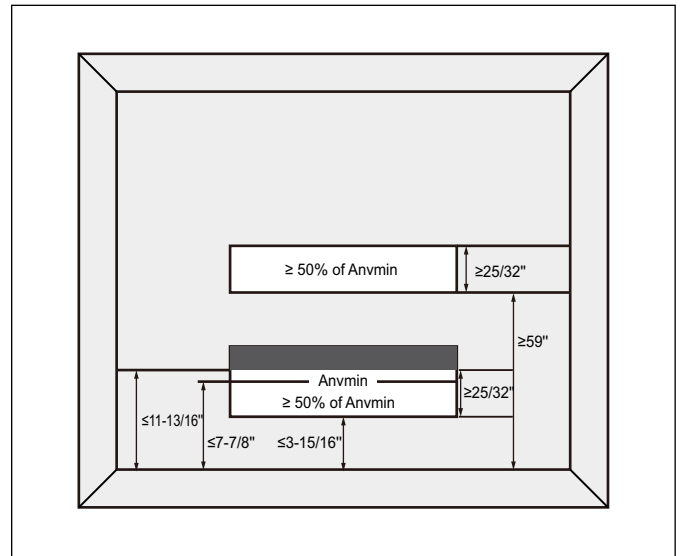

Figure 9

The minimum opening area for connected rooms:

A		$m_c$		$m_{max}$		$An_{vmin}$	
ft <sup>2</sup>	m <sup>2</sup>	lb-oz	kg	lb-oz	kg	ft <sup>2</sup>	m <sup>2</sup>
100	9.2	15-8	7	3-6	1.5	2.0	0.19
120	11.1	15-8	7	4-1	1.8	1.8	0.18
140	13.0	15-8	7	4-11	2.1	1.7	0.17
160	14.8	15-8	7	5-6	2.4	1.6	0.16
180	16.7	15-8	7	6-1	2.7	1.5	0.15
200	18.5	15-8	7	6-12	3.0	1.4	0.14
220	20.4	15-8	7	7-7	3.3	1.3	0.13
240	22.2	15-8	7	8-2	3.6	1.2	0.12
260	24.1	15-8	7	8-13	3.9	1.1	0.11
280	26.0	15-8	7	9-7	4.3	0.9	0.10
300	27.8	15-8	7	10-2	4.6	0.8	0.09
320	29.7	15-8	7	10-13	4.9	0.7	0.08
340	31.5	15-8	7	11-8	5.2	0.6	0.07
360	33.4	15-8	7	12-3	5.5	0.5	0.05
380	35.3	15-8	7	12-14	5.8	0.4	0.04
400	37.1	15-8	7	13-9	6.1	0.3	0.03
420	39.0	15-8	7	14-3	6.4	0.1	0.02
440	40.8	15-8	7	14-14	6.7	0.0	0.01
460	42.7	15-8	7	15-9	7.0	0.0	0.00

Table 4

Note: Take the  $M_c=15lb$  8oz as an example.

For appliances serving one or more rooms with an air duct system, The room area calculation shall be determined based on the total area of the conditioned space (TA) connected by ducts taking into consideration that the circulating airflow distributed to all the rooms by the appliance integral indoor fan will mix and dilute the leaking refrigerant before entering any room.

**3.4.2 The Allowed Maximum Refrigerant Charge and Required Minimum Room Area**

If the fan incorporated to an appliance is continuously operated or operation is initiated by a REFRIGERANT DETECTION SYSTEM with a sufficient CIRCULATION AIRFLOW rate, the allowable maximum refrigerant charge (Mmax) and the required minimum room area (Amin/TAmin) is shown in Table 5 and Table 6 to Table 8.

The allowable maximum refrigerant charges:

A/TA		m <sub>max</sub>		A/TA		m <sub>max</sub>	
ft <sup>2</sup>	m <sup>2</sup>	lb-oz	kg	ft <sup>2</sup>	m <sup>2</sup>	lb-oz	kg
30	2.8	0-14	0.4	250	23.2	8-6	3.8
40	3.7	1-5	0.6	260	24.2	8-9	3.9
50	4.6	1-9	0.7	270	25.1	9-0	4.1
60	5.6	1-16	0.9	280	26.0	9-7	4.3
70	6.5	2-3	1	290	26.9	9-11	4.4
80	7.4	2-10	1.2	300	27.9	10-2	4.6
90	8.4	2-14	1.3	310	28.8	10-5	4.7
100	9.3	3-5	1.5	320	29.7	10-12	4.9
110	10.2	3-8	1.6	330	30.7	11-0	5.0
120	11.1	3-15	1.8	340	31.6	11-7	5.2
130	12.1	4-3	1.9	350	32.5	11-10	5.3
140	13.0	4-10	2.1	360	33.4	12-2	5.5
150	13.9	5-1	2.3	370	34.4	12-5	5.6
160	14.9	5-5	2.4	380	35.3	12-12	5.8
170	15.8	5-12	2.6	390	36.2	13-0	5.9
180	16.7	5-15	2.7	400	37.2	13-7	6.1
190	17.7	6-6	2.9	410	38.1	13-14	6.3
200	18.6	6-10	3.0	420	39.0	14-1	6.4
210	19.5	7-1	3.2	430	39.9	14-8	6.6
220	20.4	7-4	3.3	440	40.9	14-12	6.7
230	21.4	7-11	3.5	450	41.8	15-3	6.9
240	22.3	7-15	3.6	460	42.7	15-6	7.0

Table 5

The required minimum room area:

m <sub>c</sub>		A <sub>min</sub> /TA <sub>min</sub>		m <sub>c</sub>		A <sub>min</sub> /TA <sub>min</sub>	
lb-oz	kg	ft <sup>2</sup>	m <sup>2</sup>	lb-oz	kg	ft <sup>2</sup>	m <sup>2</sup>
2-2	1.0	65.1	6.1	10-2	4.6	299.1	27.8
2-9	1.2	78.1	7.3	10-9	4.8	312.1	29.0
3-0	1.4	91.1	8.5	11-0	5.0	325.1	30.3
3-7	1.6	104.1	9.7	11-7	5.2	338.2	31.5
3-15	1.8	117.1	10.9	11-14	5.4	351.2	32.7
4-6	2.0	130.1	12.1	12-5	5.6	364.2	33.9
4-13	2.2	143.1	13.3	12-12	5.8	377.2	35.1
5-4	2.4	156.1	14.5	13-3	6.0	390.2	36.3
5-11	2.6	169.1	15.8	13-10	6.2	403.2	37.5
6-2	2.8	182.1	17.0	14-1	6.4	416.2	38.7
6-9	3.0	195.1	18.2	14-8	6.6	429.2	39.9
7-0	3.2	208.1	19.4	14-15	6.8	442.2	41.1
7-7	3.4	221.1	20.6	15-6	7.0	455.2	42.3
7-15	3.6	234.1	21.8	15-14	7.2	468.2	43.5
8-6	3.8	247.1	23.0	16-5	7.4	481.2	44.7
8-13	4.0	260.1	24.2	16-12	7.6	494.2	46.0
9-4	4.2	273.1	25.4	17-3	7.8	507.2	47.2
9-11	4.4	286	26.6				

Table 6

The required minimum room area if installed at an altitude over 2000ft:

Altitude [m]		601-800		801-1000		1001-1200		1201-1400		1401-1600		1601-1800		1801-2000	
Altitude [ft]		1970-2625		2626-3280		3281-3938		3940-4593		4596-5250		5251-5905		5908-6562	
$m_c$		$A_{min}/TA_{min}$													
lb-oz	kg	ft <sup>2</sup>	m <sup>2</sup>	ft <sup>2</sup>	m <sup>2</sup>	ft <sup>2</sup>	m <sup>2</sup>	ft <sup>2</sup>	m <sup>2</sup>	ft <sup>2</sup>	m <sup>2</sup>	ft <sup>2</sup>	m <sup>2</sup>	ft <sup>2</sup>	m <sup>2</sup>
2	0.9	60.2	5.6	62.0	5.8	63.2	5.9	64.9	6.1	66.1	6.2	67.9	6.4	69.7	6.5
3	1.4	90.3	8.4	93.0	8.7	94.7	8.8	97.4	9.1	99.1	9.3	101.8	9.5	104.5	9.7
4	1.8	120.4	11.2	123.9	11.6	126.3	11.8	129.8	12.1	132.2	12.3	135.7	12.7	139.3	13.0
5	2.3	150.5	14.0	154.9	14.4	157.8	14.7	162.3	15.1	165.2	15.4	169.6	15.8	174.1	16.2
6	2.7	180.5	16.8	185.9	17.3	189.4	17.6	194.7	18.1	198.2	18.5	203.5	19.0	208.9	19.4
7	3.2	210.6	19.6	216.8	20.2	220.9	20.6	227.1	21.1	231.3	21.5	237.5	22.1	243.7	22.7
8	3.6	240.7	22.4	247.8	23.1	252.5	23.5	259.6	24.2	264.3	24.6	271.4	25.3	278.5	25.9
9	4.1	270.8	25.2	278.8	25.9	284.1	26.4	292.0	27.2	297.3	27.7	305.3	28.4	313.3	29.1
10	4.5	300.9	28.0	309.7	28.8	315.6	29.4	324.5	30.2	330.4	30.7	339.2	31.6	348.1	32.4
11	5.0	331.0	30.8	340.7	31.7	347.2	32.3	356.9	33.2	363.4	33.8	373.1	34.7	382.9	35.6
12	5.4	361.0	33.6	371.7	34.6	378.7	35.2	389.3	36.2	396.4	36.9	407.0	37.9	417.7	38.8
13	5.9	391.1	36.4	402.6	37.4	410.3	38.2	421.8	39.2	429.5	39.9	441.0	41.0	452.5	42.1
14	6.4	421.2	39.2	433.6	40.3	441.8	41.1	454.2	42.2	462.5	43.0	474.9	44.2	487.3	45.3
15	6.8	451.3	42.0	464.6	43.2	473.4	44.0	486.7	45.3	495.5	46.1	508.8	47.3	522.1	48.5
16	7.3	481.4	44.8	495.5	46.1	505.0	47.0	519.1	48.3	528.5	49.1	542.7	50.5	556.9	51.8
17	7.7	511.4	47.6	526.5	49.0	536.5	49.9	551.6	51.3	561.6	52.2	576.6	53.6	591.7	55.0
18	8.2	541.5	50.4	557.5	51.8	568.1	52.8	584.0	54.3	594.6	55.3	610.5	56.8	626.5	58.2
19	8.6	571.6	53.1	588.4	54.7	599.6	55.8	616.4	57.3	627.6	58.4	644.5	59.9	661.3	61.5
20	9.1	601.7	55.9	619.4	57.6	631.2	58.7	648.9	60.3	660.7	61.4	678.4	63.1	696.1	64.7

Table 7

Altitude [m]		2001-2200		2201-2400		2401-2600		2601-2800		2801-3000		3001-3200		above 3200	
Altitude [ft]		6565-7218		7221-7874		7877-8530		8533-9186		9190-9843		9846-10500		above 10500	
$m_c$		$A_{min}/TA_{min}$													
lb-oz	kg	ft <sup>2</sup>	m <sup>2</sup>	ft <sup>2</sup>	m <sup>2</sup>	ft <sup>2</sup>	m <sup>2</sup>	ft <sup>2</sup>	m <sup>2</sup>	ft <sup>2</sup>	m <sup>2</sup>	ft <sup>2</sup>	m <sup>2</sup>	ft <sup>2</sup>	m <sup>2</sup>
2	0.9	71.4	6.7	73.8	6.9	75.5	7.1	77.9	7.3	80.3	7.5	82.6	7.7	82.6	7.7
3	1.4	107.1	10.0	110.6	10.3	113.3	10.6	116.8	10.9	120.4	11.2	123.9	11.6	123.9	11.6
4	1.8	142.8	13.3	147.5	13.7	151.0	14.1	155.8	14.5	160.5	15.0	165.2	15.4	165.2	15.4
5	2.3	178.5	16.6	184.4	17.2	188.8	17.6	194.7	18.1	200.6	18.7	206.5	19.2	206.5	19.2
6	2.7	214.2	19.9	221.2	20.6	226.5	21.1	233.6	21.8	240.7	22.4	247.8	23.1	247.8	23.1
7	3.2	249.8	23.3	258.1	24.0	264.3	24.6	272.6	25.4	280.8	26.1	289.1	26.9	289.1	26.9
8	3.6	285.5	26.6	295.0	27.4	302.0	28.1	311.5	29.0	320.9	29.9	330.4	30.7	330.4	30.7
9	4.1	321.2	29.9	331.8	30.9	339.8	31.6	350.4	32.6	361.0	33.6	371.7	34.6	371.7	34.6
10	4.5	356.9	33.2	368.7	34.3	377.5	35.1	389.3	36.2	401.1	37.3	412.9	38.4	412.9	38.4
11	5.0	392.6	36.5	405.6	37.7	415.3	38.6	428.3	39.8	441.3	41.0	454.2	42.2	454.2	42.2
12	5.4	428.3	39.8	442.4	41.1	453.0	42.1	467.2	43.5	481.4	44.8	495.5	46.1	495.5	46.1
13	5.9	464.0	43.1	479.3	44.6	490.8	45.6	506.1	47.1	521.5	48.5	536.8	49.9	536.8	49.9
14	6.4	499.6	46.5	516.2	48.0	528.5	49.1	545.1	50.7	561.6	52.2	578.1	53.8	578.1	53.8
15	6.8	535.3	49.8	553.0	51.4	566.3	52.7	584.0	54.3	601.7	55.9	619.4	57.6	619.4	57.6
16	7.3	571.0	53.1	589.9	54.8	604.0	56.2	622.9	57.9	641.8	59.7	660.7	61.4	660.7	61.4
17	7.7	606.7	56.4	626.8	58.3	641.8	59.7	661.9	61.5	681.9	63.4	702.0	65.3	702.0	65.3
18	8.2	642.4	59.7	663.6	61.7	679.5	63.2	700.8	65.2	722.0	67.1	743.3	69.1	743.3	69.1
19	8.6	678.1	63.0	700.5	65.1	717.3	66.7	739.7	68.8	762.1	70.8	784.5	72.9	784.5	72.9
20	9.1	713.8	66.4	737.4	68.5	755.0	70.2	778.6	72.4	802.2	74.6	825.8	76.8	825.8	76.8

Table 8

The minimum circulation airflow:

$m_c$		$Q_{min}$		$m_c$		$Q_{min}$	
lb-oz	kg	CFM	m <sup>3</sup> /h	lb-oz	kg	CFM	m <sup>3</sup> /h
2-2	1.0	118	200	10-2	4.6	540	917
2-9	1.2	141	240	10-9	4.8	564	957
3-0	1.4	165	280	11-0	5.0	587	997
3-7	1.6	188	319	11-7	5.2	611	1037
3-15	1.8	212	359	11-14	5.4	634	1077
4-6	2.0	235	399	12-5	5.6	658	1117
4-13	2.2	259	439	12-12	5.8	681	1157
5-4	2.4	282	479	13-3	6.0	704	1197
5-11	2.6	306	519	13-10	6.2	728	1236
6-2	2.8	329	559	14-1	6.4	751	1276
6-9	3.0	352	599	14-8	6.6	775	1316
7-0	3.2	376	638	14-15	6.8	798	1356
7-7	3.4	399	678	15-6	7.0	822	1396
7-15	3.6	423	718	15-14	7.2	845	1436
8-6	3.8	446	758	16-5	7.4	869	1476
8-13	4.0	470	798	16-12	7.6	892	1515
9-4	4.2	493	838	17-3	7.8	916	1555
9-11	4.4	517	878				

Table 9

**CAUTION**

**Min. room area and airflow required!**

The allowable maximum refrigerant charge in Table 5 or the required minimum room area in Table 6 to Table 8 is available only if the following conditions are met:

Minimum velocity of 3.28ft/s, which is calculated as the indoor unit airflow divided by the nominal face area of the outlet. And the grill area shall not be deducted.

Minimum airflow rate must meet the corresponding values in Table 9, which is related to the actual refrigerant charge of the system (Mc).

R-454B refrigerant leakage sensor is installed.



The maximum refrigerant limit described above applies to unventilated areas. If adding additional measures, such as areas with mechanical ventilation or natural ventilation, The maximum refrigerant charge can be increased or the minimum room area can be reduced.

R-454B refrigerant leakage sensor is designed for the indoor unit, meets the incorporated circulation airflow requirements, the maximum refrigerant charge or minimum room area can be determined according to Table 5 or Table 6 to Table 8.

**CAUTION**

**Min. room area and airflow required!**

If the actual room area, air outlet height, and refrigerant charge amount are not reflected in the above table, more severe cases need to be considered according to the data in the Table 4 to Table 9.

## 4 Unit Preparation

### 4.1 Prepare the Unit for Installation

- Check for damage and report promptly to the carrier any damage found to the unit (Figure 10).
- The charge port can be used to ensure the refrigerant charge has been retained during shipment.

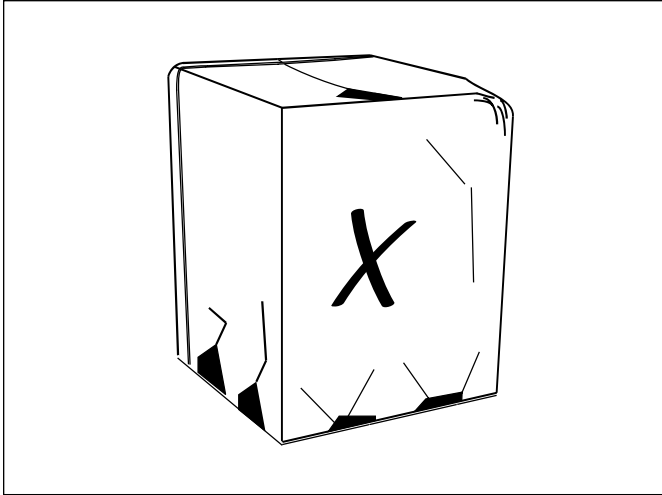

Figure 10

**NOTICE**

**Product damage!**

Appliances shall be transported, marked and stored in accordance with the applicable warnings from “1.3 Safety” in mind. The appliance shall be stored so as to prevent mechanical damage from occurring.

## 5 Setting the Unit

### 5.1 Pad Installation

When installing the unit on a support pad, such as a concrete slab, consider the following:

- The pad must be at least 1-2” larger than the unit on all sides.
- The pad must be separated from any structure.
- The pad must be level.
- The pad must be high enough above grade to allow for drainage.
- The pad location must comply with National, State, and local codes.



These instructions are intended to provide a method to tie-down system to cement slab as a securing procedure for high wind areas. Check local codes for tie-down methods and protocols.

**NOTICE**

**Product damage!**

The outdoor unit vapour service valve and liquid service valve need to be protected. do not grab them when moving the outdoor unit.

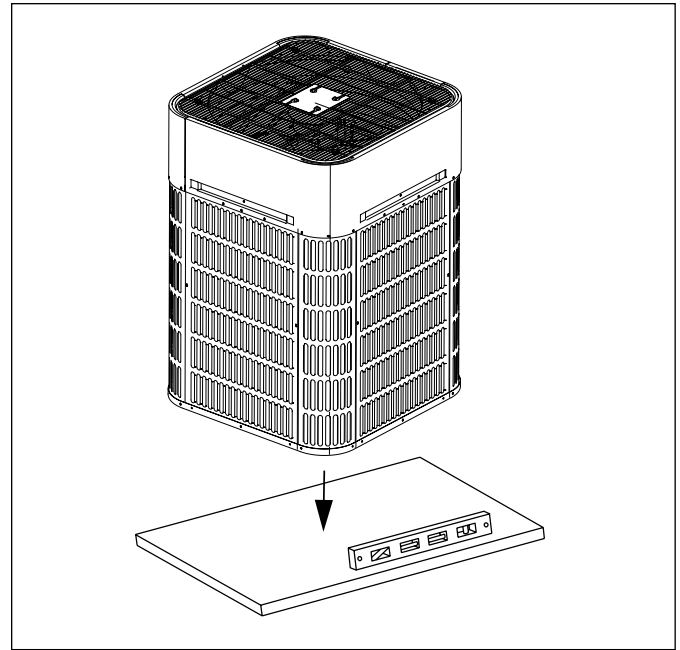

Figure 11

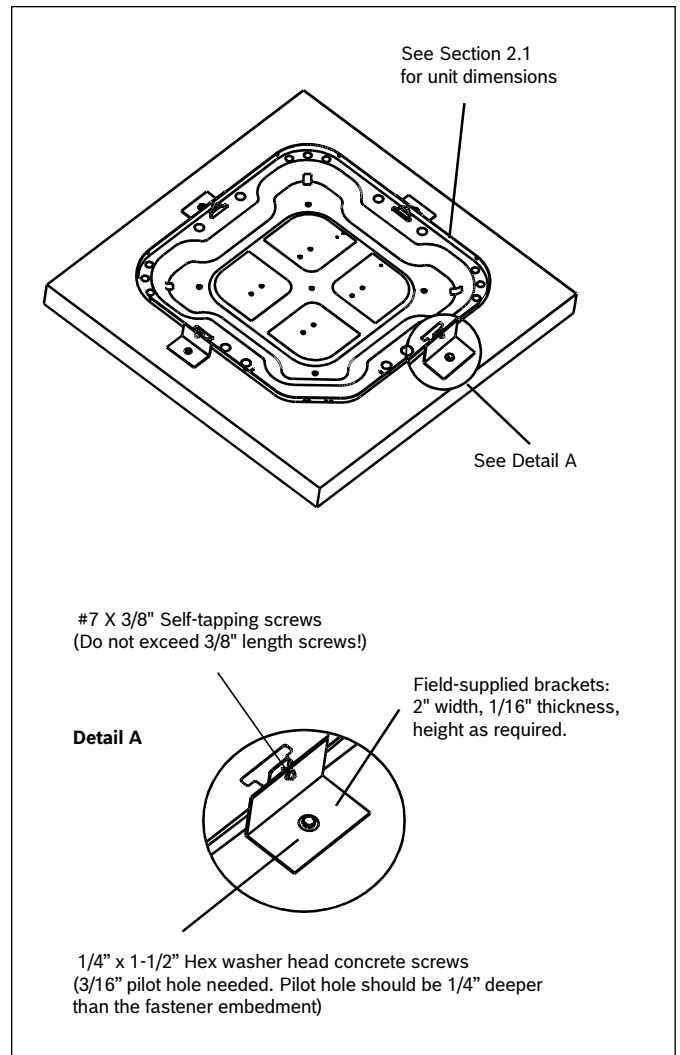

Figure 12

## 5.2 Mounting Antenna



The antenna is used to transmit data to the cloud and will have the strongest signal strength mounted furthest away from a wall or building.



Refer to “3.3 Location Restrictions” for unit clearance requirements.

1. Mount antenna on top of louver 3 (Refer to Figure 13) on the left or right side of the unit depending on which is furthest from a wall. Slide the antenna downwards to mount the antenna and secure the cable using the 2 movable clips on the cable. Refer to Figure 14.

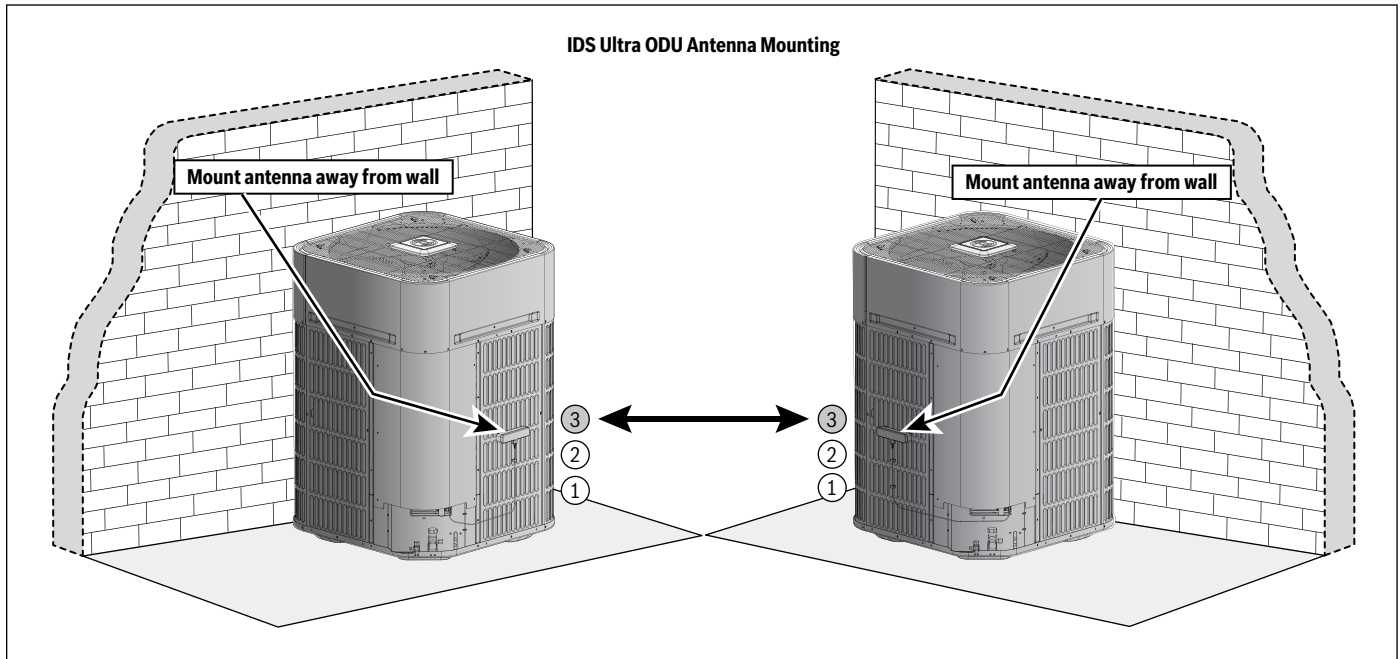

Figure 13

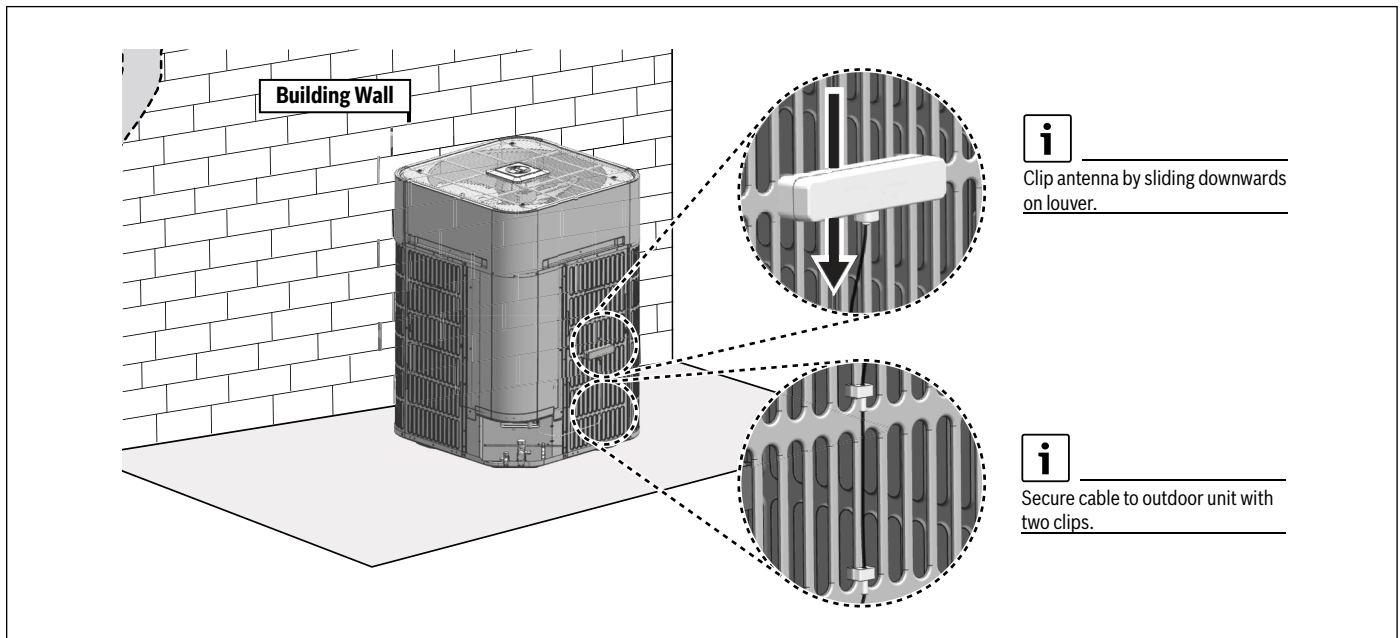

Figure 14

## 6 Refrigerant Line Considerations

### 6.1 Refrigerant Line and Service Valve Connection Sizes

Model	Suction Line	Liquid Line	Suction Line Connection	Liquid Line Connection
	Dimensions in inches			
BOVB60-19	7/8	3/8	7/8	3/8
BOVB36-19	3/4	3/8	3/4	3/8

Table 10 Refrigerant line and service valve connection sizes

### 6.2 Required Refrigerant Line Length

Determine required line length (Figure 15). Refer to “3.2 Refrigerant Piping Limits”.

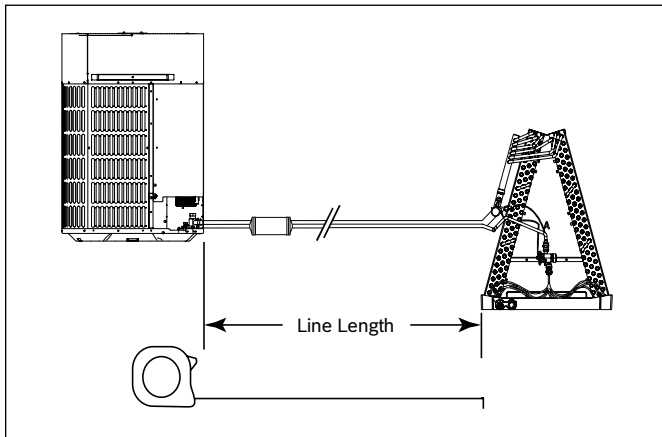

Figure 15 Required refrigerant line length

### 6.3 Refrigerant Line Insulation



The Suction Line must always be insulated. DO NOT allow the Liquid Line and Suction Line to come in direct (metal to metal) contact.

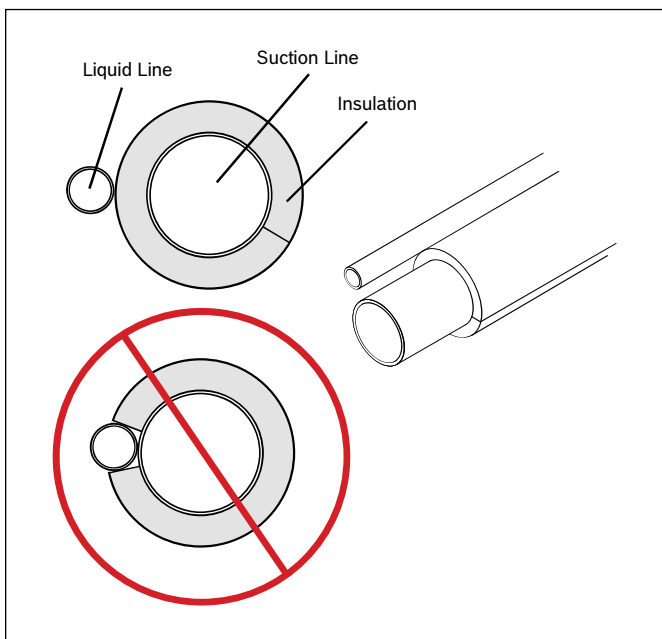

Figure 16

## 6.4 Reuse Existing Refrigerant Lines



### CAUTION

#### MINOR TO MODERATE BURN!

If using existing refrigerant lines, make certain that all joints are brazed, not soldered.

For retrofit applications, where the existing refrigerant lines will be used, the following precautions should be taken:

- Ensure that the refrigerant lines are the correct size. Refer to “3.2 Refrigerant Piping Limits” and Table 3.
- Ensure that the refrigerant lines are free of leaks, acid, and oil.
- If the existing tube has been used with another refrigerant (e.g. R410A), then the tube should be replaced.



The manufacturer recommends installing only approved matched indoor and outdoor systems. All of the manufacturer’s split systems are AHRI rated only with TXV indoor systems. The benefits of installing approved matched indoor and outdoor split systems are maximum efficiency, optimum performance and the best overall system reliability.

## 7 Refrigerant Line Routing

### 7.1 Precautions



Take precautions to prevent noise within the building structure due to vibration transmission from the refrigerant lines. For example:

- When the refrigerant lines have to be fastened to floor joists or other framing in a structure, use isolation type hangers.
- Isolation hangers should also be used when refrigerant lines are run in stud spaces or enclosed ceilings.
- Where the refrigerant lines run through a wall or sill, they should be insulated and isolated.
- Isolate the lines from all ductwork.
- Minimize the number of 90° turns.

### NOTICE

#### Product damage!

The pipe-work including piping material, pipe routing, and installation shall include protection from physical damage in operation and service, and be in compliance with national and local codes and standards, such as ASHRAE 15, ASHRAE 15.2, IAPMO Uniform Mechanical Code, ICC International Mechanical Code. Inspection prior to being covered or enclosed, or is compliant with CSA B52. All field joints shall be accessible for inspection prior to being covered or enclosed.

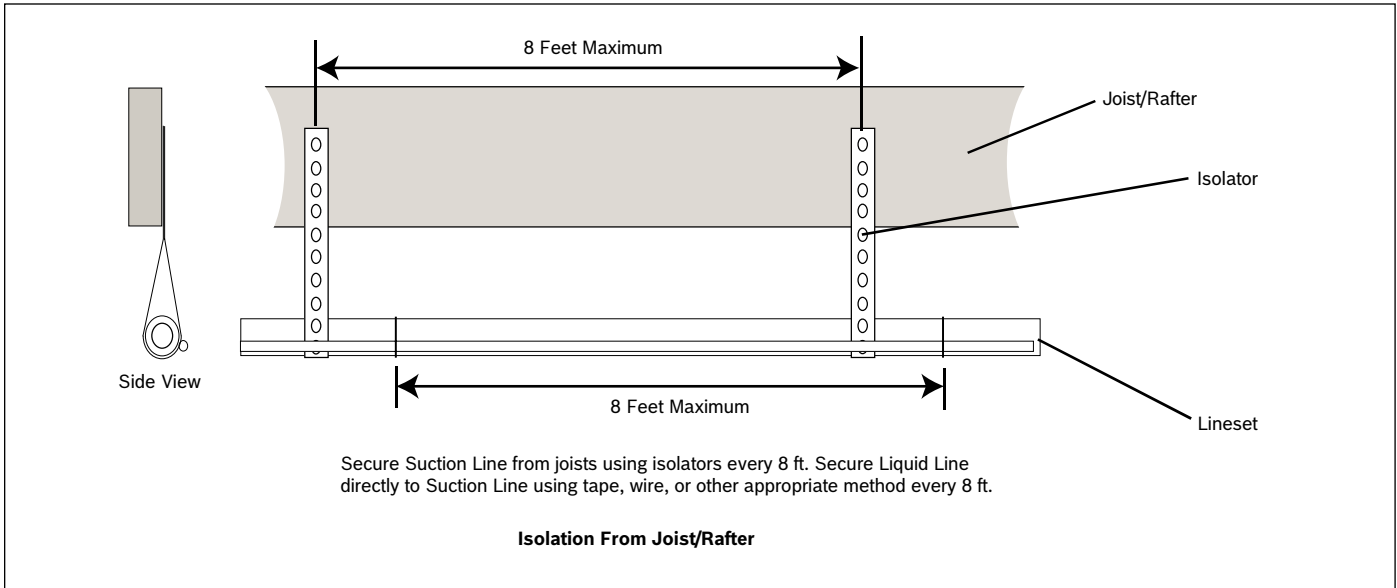

Figure 17

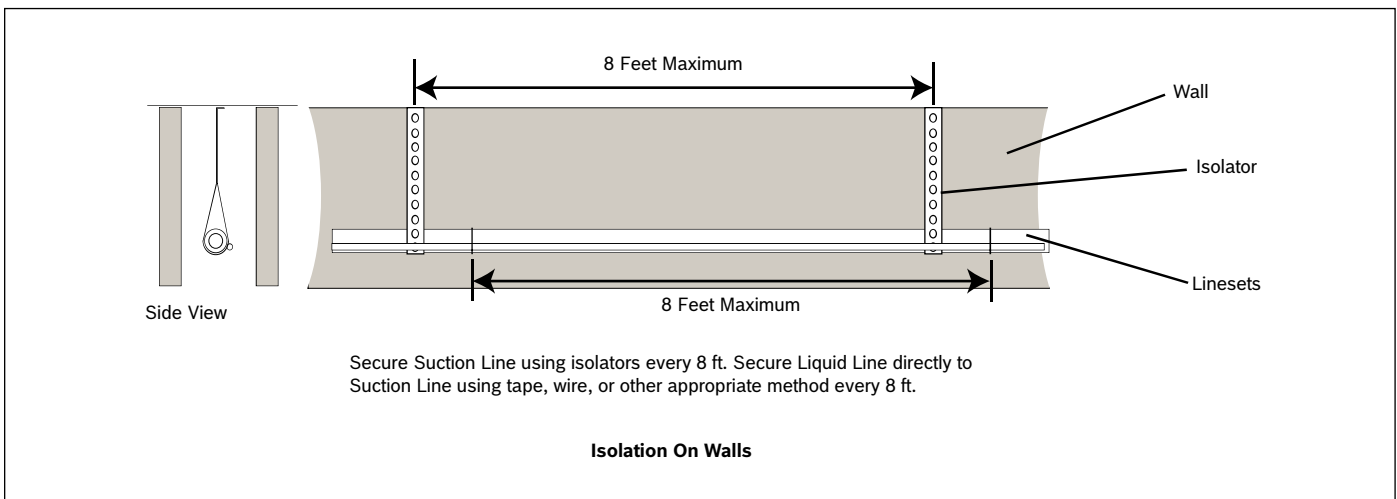

Figure 18



Comply with National, State, and local codes when isolating linesets from joists, rafters, walls, or other structural elements.

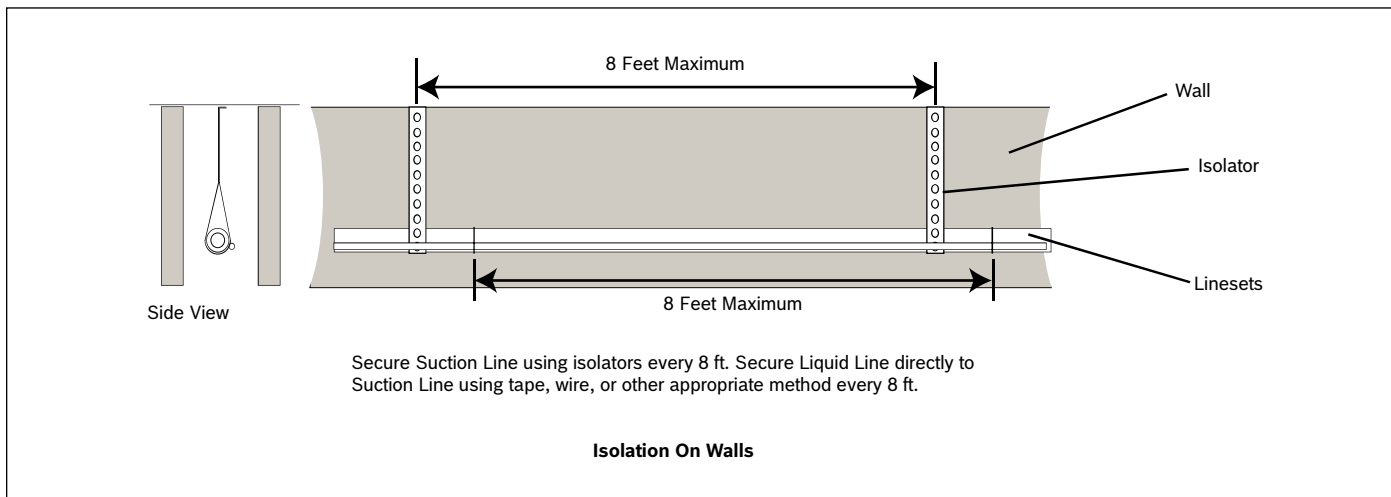

Figure 19

## 8 Refrigerant Line Connection

All joints made in the installation between parts of the REFRIGERATING SYSTEM, with at least one part charged, shall be made in accordance with the following:

- A brazed, welded, or mechanical connection shall be made before opening the valves to permit refrigerant to flow between the REFRIGERATING SYSTEM parts. A vacuum valve shall be provided to evacuate the interconnecting pipe or any uncharged REFRIGERATING SYSTEM part.
- Mechanical connectors used indoors shall comply with ISO 14903. When mechanical connectors are reused indoors, sealing parts shall be renewed. When flared joints are reused indoors, the flare part shall be refabricated.
- Refrigerant tubing shall be protected or enclosed to avoid damage.
- Flexible refrigerant connectors (such as connecting lines between the indoor and outdoor unit) that may be displaced during NORMAL OPERATION shall be protected against mechanical damage.

Compliance is checked according to the installation instructions and a trial installation, if necessary.

Field-made refrigerant joints indoors shall be tightness tested. The test method shall have a sensitivity of 5 grams per year of refrigerant or better under a pressure of at least 0.25 times the maximum allowable pressure. No leak shall be detected.

For installations with field applied joints that are exposed in the occupied space these joints shall be at least one of the following:

- Mechanical joints in compliance with ISO 14903 or UL 207 (U.S. only).
- Welded or brazed joints.
- Joints in enclosures that vent to the unit or to the outside.

Compliance is checked by inspection and tests.

## 9 Refrigerant Line Brazing or Crimping



All R-454B products have a red tag on the refrigerant lines to indicate the product is charged with A2L refrigerant. It should not be removed.

### 9.1 Braze the Refrigerant Lines

1. Remove caps or plugs. Use a deburring tool to deburr the pipe ends. Clean both internal and external surfaces of the tubing using an emery cloth.

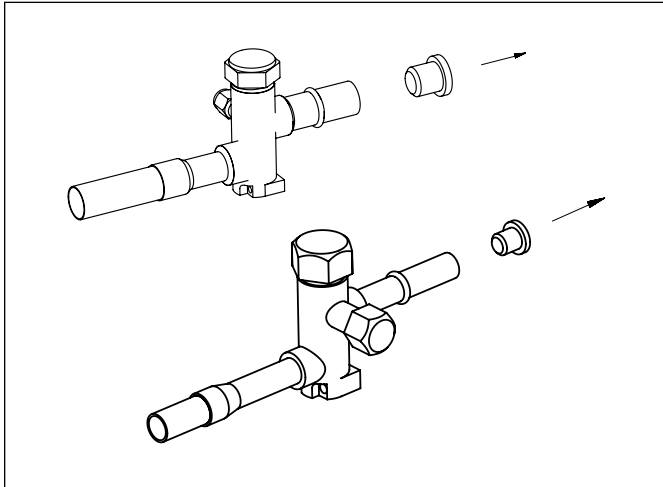

Figure 20



The locking cap might be required by your local code enforcement.

2. Remove the pressure tap cap and the valve core from both service valves.

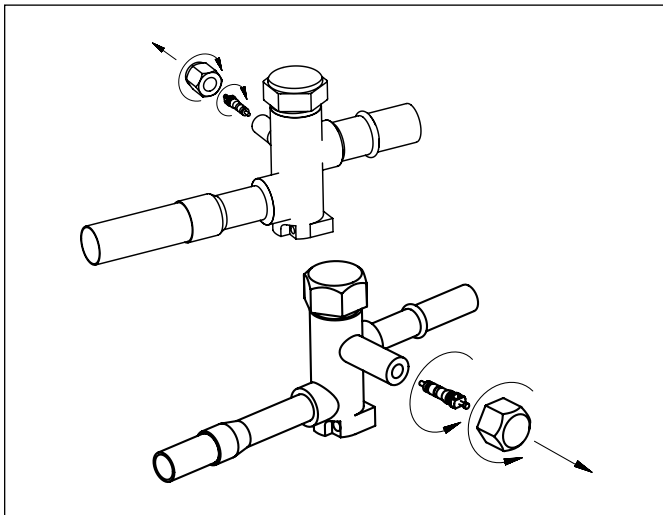

Figure 21

3. Purge the refrigerant lines and indoor coil with dry nitrogen.

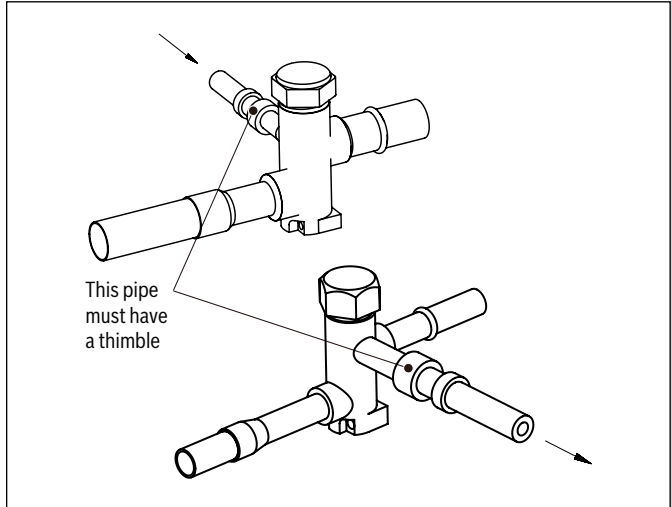

Figure 22

4. Wrap a wet rag around the valve body to avoid heat damage and continue the dry nitrogen purge (Figure 23).

Braze the refrigerant lines to the service valves.

Braze the filter drier to the Liquid Line.



All units come standard with a bi-flow filter drier. Braze the filter drier to the liquid line, using caution not to push the refrigerant line too hard past the stop within the filter drier (this could damage the drier).



Remove the wet rag before stopping the dry nitrogen purge.

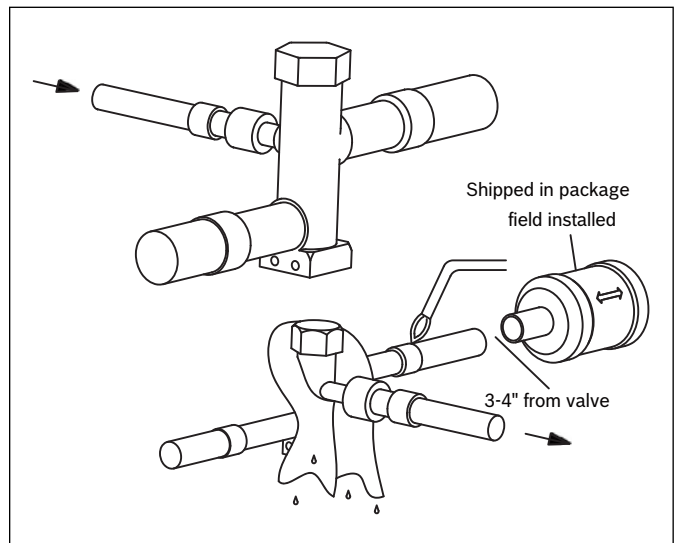

Figure 23

5. Replace the pressure tap caps and the valve cores after the service valves have cooled.

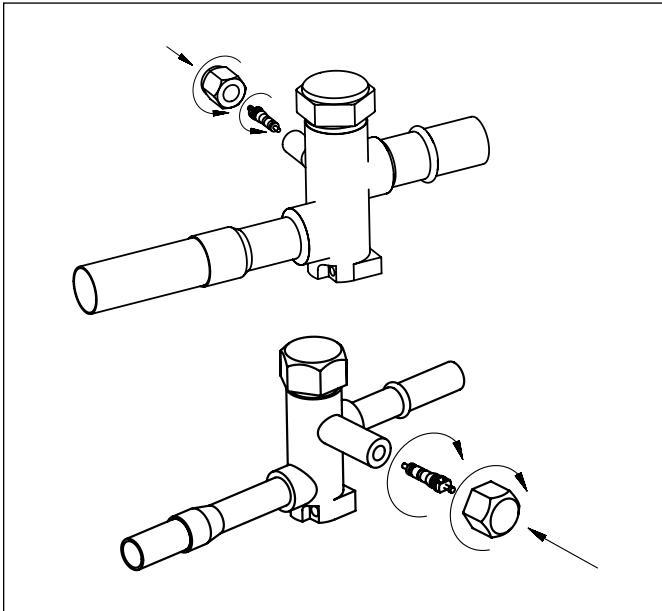

Figure 24

## 9.2 Crimping the Refrigerant Lines

1. Remove caps or plugs. Use a deburring tool to deburr the pipe ends. Clean both internal and external surfaces of the tubing using an emery cloth.

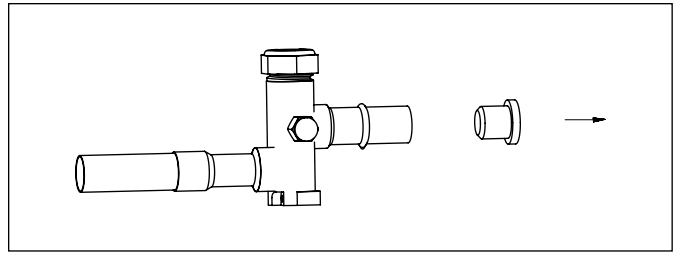

Figure 25

2. Insert the tube fully into the fitting. Ensure tube is fully inserted prior to pressing. Ensure pipework is correctly aligned prior to pressing.

### **! WARNING**

#### **Flammable refrigerant, product damage!**

Complete the joint with the approved tool. Press once only.

Specific model selection and operational procedures shall conform to the Press-to-Connect Refrigerant Fittings installation and operation manual. Improper installation may cause refrigerant leakage.

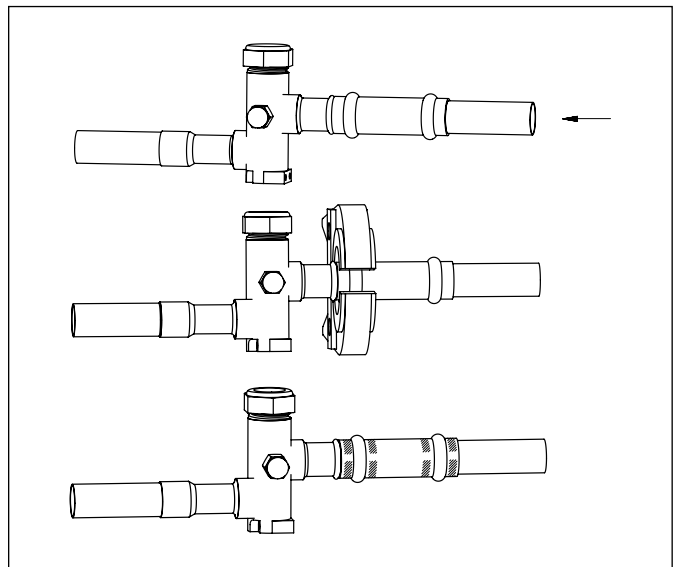

Figure 26

## 10 Refrigerant Line Leak Check

### 10.1 Check For Leaks

1. Pressurize the refrigerant lines and evaporator coil to 250 PSIG using dry nitrogen.

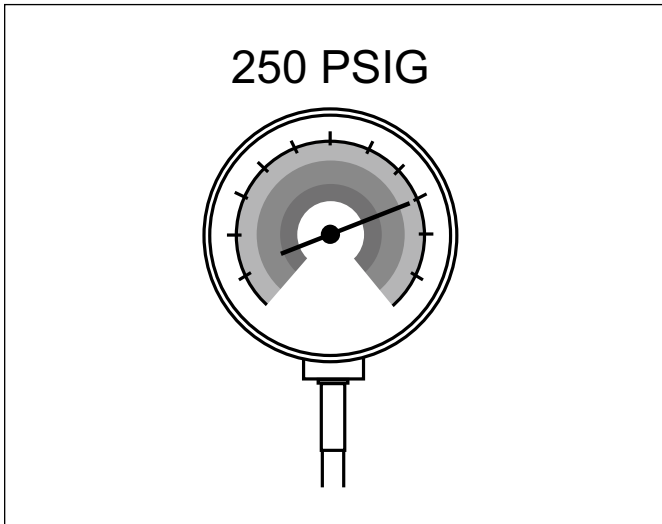

Figure 27

2. Check for leaks by using a soapy solution or bubbles at each brazed or crimped location.

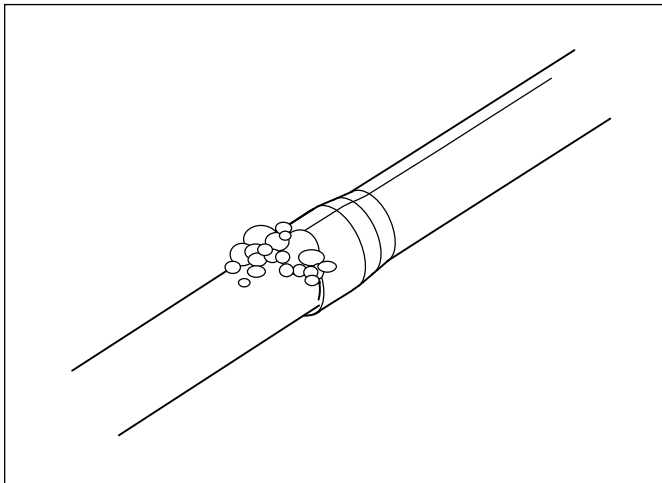

Figure 28

## 11 Evacuation

### 11.1 Evacuate the Refrigerant Lines and Indoor Coil



Do not open the service valves until the refrigerant lines and indoor coil leak check and evacuation are complete.

1. Evacuate until the micron gauge reads no higher than 350 microns, then close the valve to the vacuum pump.

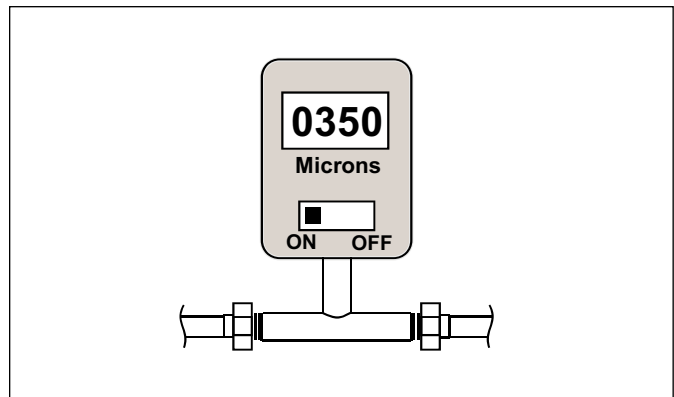

Figure 29

2. Observe the micron gauge. Evacuation is complete if the micron gauge does not rise above 500 microns in one (1) minute.

Once evacuation is complete, turn off the vacuum pump and micron gauge, and close the valves on the manifold gauge set.



Figure 30

## 12 Service Valves

### 12.1 Open the Service Valves



**WARNING**

**Moderate to severe burns!**

Extreme caution should be exercised when opening the Liquid Line Service Valve. Turn counterclockwise until the valve stem just touches the rolled edge. No torque is required. Failure to follow this warning will result in abrupt release of system charge and may result in personal injury and /or property damage.



Leak check and evacuation must be completed before opening the service valves. The brazed or crimped lineset valves should be used for leak checking and vacuuming. Using the separate suction port for this process will result in loss of charge.



The Suction Service Valve must be opened first BEFORE opening the Liquid Service Valve.

1. Remove Service Valve Cap (Figure 31).
2. Fully insert hex wrench into the stem and back out counterclockwise until valve stem just touches the rolled edge (approximately five (5) turns.)
3. Replace the Valve Stem Cap to prevent leaks. Tighten finger tight plus an additional 1/6 turn.
4. Repeat STEPS 1 - 3 for Liquid Service Valve.

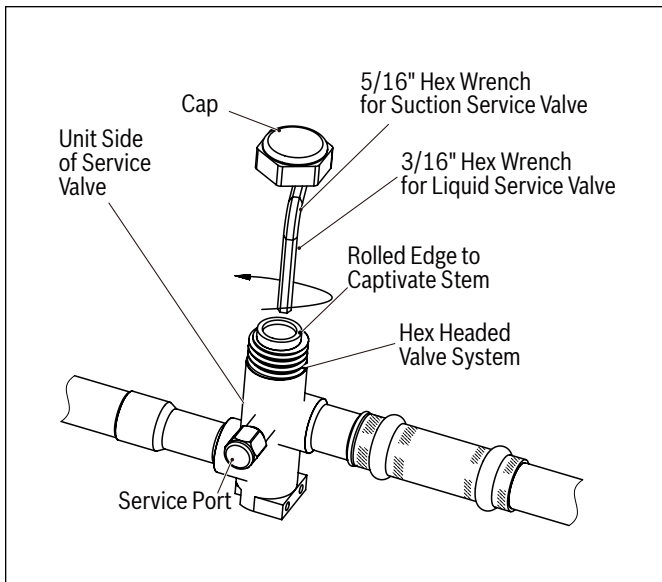

Figure 31

## 13 Electrical - Low Voltage

### 13.1 Low Voltage Maximum Wire Length

Table 11 defines the maximum total length of low voltage wiring from the outdoor unit to the indoor unit.

Hyper-Link (M1 M2) Communication Wire Size	Max. Wire Length
16/18 AWG	300 Ft.
P Q Communication Wire Size	Max. Wire Length
16/18 AWG	150 Ft.

Table 11

#### WARNING

##### Personal injury, property damage!

Installation and servicing of air conditioning equipment can be hazardous due to internal refrigerant pressure and live electrical components. Only trained and qualified service personnel should install or service this equipment. Installation and service performed by unqualified persons can result in property damage, personal injury, or death.

#### WARNING

##### Risk of electrical shock!

Disconnect all remote power supplies before installing or servicing any portion of the system. Failure to disconnect power supplies can result in property damage, personal injury, or death.

#### CAUTION

##### Personal injury!

The connectors of Hyper-Link (M1 M2) / P Q communication wires must be connected reliably and protected by insulation. The unused wires should be insulated, and the copper wires should not be exposed. Sharp metal edges can cause injury. When installing the unit, use care to avoid sharp edges. Avoid sharp metal edges for wires to prevent wear, or it may lead to short circuit or electric leakage and cause danger.

#### NOTICE

##### Product damage!

Electrostatic discharge can affect electronic components. Take care during unit installation and service to protect the unit's electronic controls. Precautions will help to avoid control exposure to electrostatic discharge by putting the unit, the control and the technician at the same electrostatic potential. Touch hand and all tools on an unpainted unit surface before performing any service procedure to neutralize electrostatic charge.

Do not connect the power cords (high voltage) to the Hyper-Link (M1 M2) / P Q communication wires (low voltage), otherwise it will damage the control board.

After connecting the power and signal wires, secure the cable tie through the rubber grommet to prevent small animals from entering the electrical control box and causing damage.

The Hyper-Link (M1 M2) / P Q communication wires should be fixed well. Otherwise, the connectors may be loose or the terminal may be damaged when they are pulled.

#### NOTICE

##### Product damage!

The Hyper-Link (M1 M2) / P Q communication wires must be routed as close as possible. Otherwise, the communication may be abnormal.

When there is strong electromagnetic interference in the environment, it is recommended to use shielded wires for Hyper-Link(M1 M2) / P Q communication wires. Otherwise, the communication may be abnormal. When using shielded wires, the shielding layer must be grounded at one end to prevent ground loops and ensure proper shielding.

Power cords and communication wires must be separated from each other with a distance of more than 2 inches. Otherwise, the communication may be abnormal.

The Hyper-Link (M1 M2) / P Q communication wires connectors are SELV connection points.

### 13.2 Thermostat Wiring

- Be sure power supply agrees with equipment nameplate.
- Power wiring and grounding of equipment must comply with local codes.
- Low voltage wiring to be No. 18 AWG minimum conductor.
- “-----” Field installed electric auxiliary heat connection
- Single-stage auxiliary heating supported by 2H thermostat
- Two-stage auxiliary heating supported by 3H thermostat
- Three stage auxiliary heating supported by 4H thermostat
- W1: The first stage of field installed electric auxiliary heat.
- W2: The second stage of field installed electric auxiliary heat.
- W3: The third stage of field installed electric auxiliary heat.
- The outdoor unit W signal is connected to the electric auxiliary heat or the first stage electric auxiliary heat.



Figure 36 to Figure 41 refers to thermostat wiring diagrams for the BOVB19 and BVB19 manufacturer matched indoor and outdoor systems. Figure 42 refer to thermostat wiring diagrams for the BOVB19 and BGH96 RevC/BGH97 Furnace manufacturer matched indoor and outdoor system.



Figure 43 to Figure 48 refer to thermostat wiring diagrams when installed with a Bosch IDS Communication Accessory Kit.



Dashed lines in the following thermostat wiring diagrams refer to optional wiring (wiring for Passive Dehumidification Function and/OR Electric Heat). For thermostat wiring please refer to the Owner's Manual of the thermostat.



B terminal to be connected with thermostat (O/B) wiring. Reversing valve energizes in heating.

**13.2.1 Communicating Set Up**

**Dip switch configurations for communicating mode (default)**

Communication mode is the factory default for this system.

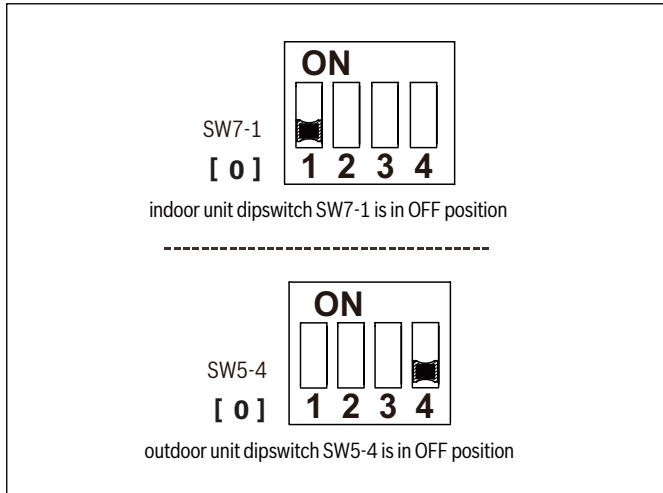

Figure 32



- The factory default mode is communication between the outdoor and indoor units and 24VAC connection with the thermostat.
- Hyper-Link(M1 M2) communication mode is only available with a matched BIVB19 indoor unit which has Hyper-Link(M1 M2) communication function.
- Use P Q communication mode when the indoor unit is only equipped with P Q communication and Hyper-Link communication is not available, such as BGH96 RevC/ BGH97 Furnace.
- If there are 2 or more systems (communication) in the same area, make sure the low voltage wires are connected to the right unit that are connected to the same refrigerant line.
- The IDS Ultra ODU can only be configured to communicating mode when installed with an IDS Ultra Air Handler, a BGH96 RevC/BGH97 Furnace, or an IDS Communication Accessory Kit.

**Low voltage wire connections with the outdoor unit, communicating**

To connect the Hyper-Link (M1 M2) / P Q communication wires:

1. Remove the communication wiring harness from the accessory bag, peel off the half-stripped wires, and plug it into CN10 to use Hyper-Link (M1 M2) communication, or CN11 to use P Q communication.

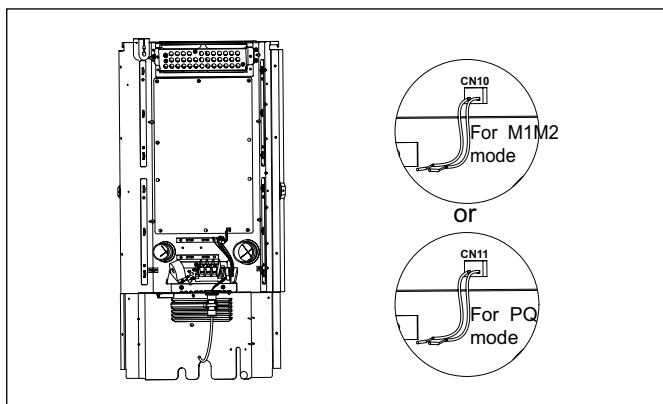

Figure 33

2. Loosen the zip tie (pos.1) and thread the field supplied low voltage wires through the hole (pos.2).

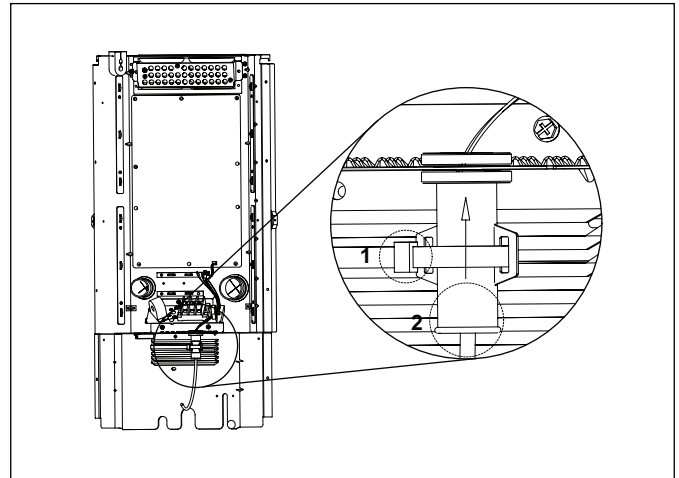

Figure 34

3. Connect the Hyper-Link(M1 M2) / P Q communication wires to the two field supplied wires (pos.1). Arrange the low voltage wires (refer to the cautions and note above). Tighten the zip tie (pos.2).

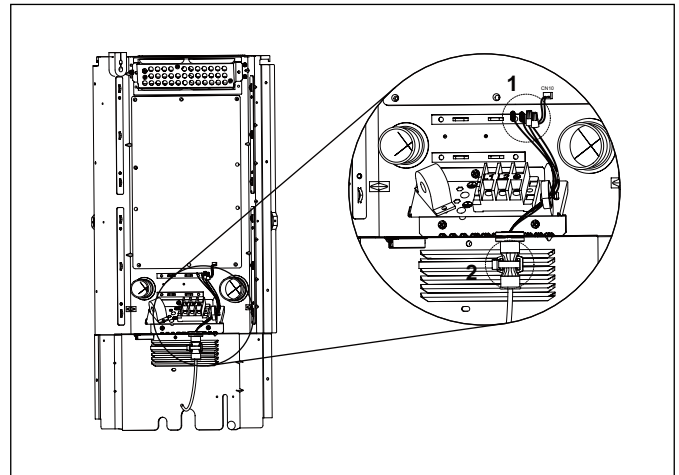

Figure 35

**Communicating thermostat wiring diagrams**

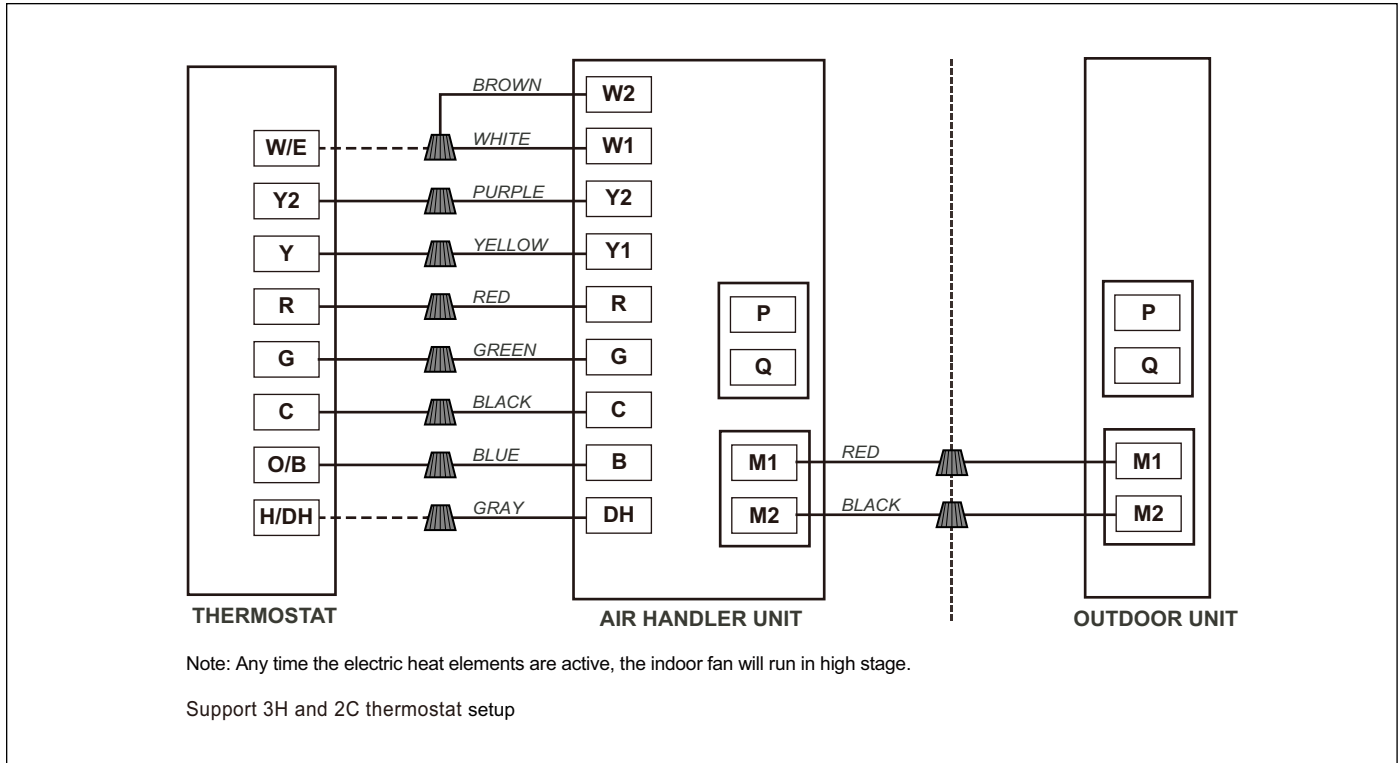

Figure 36 Control wiring for HP systems

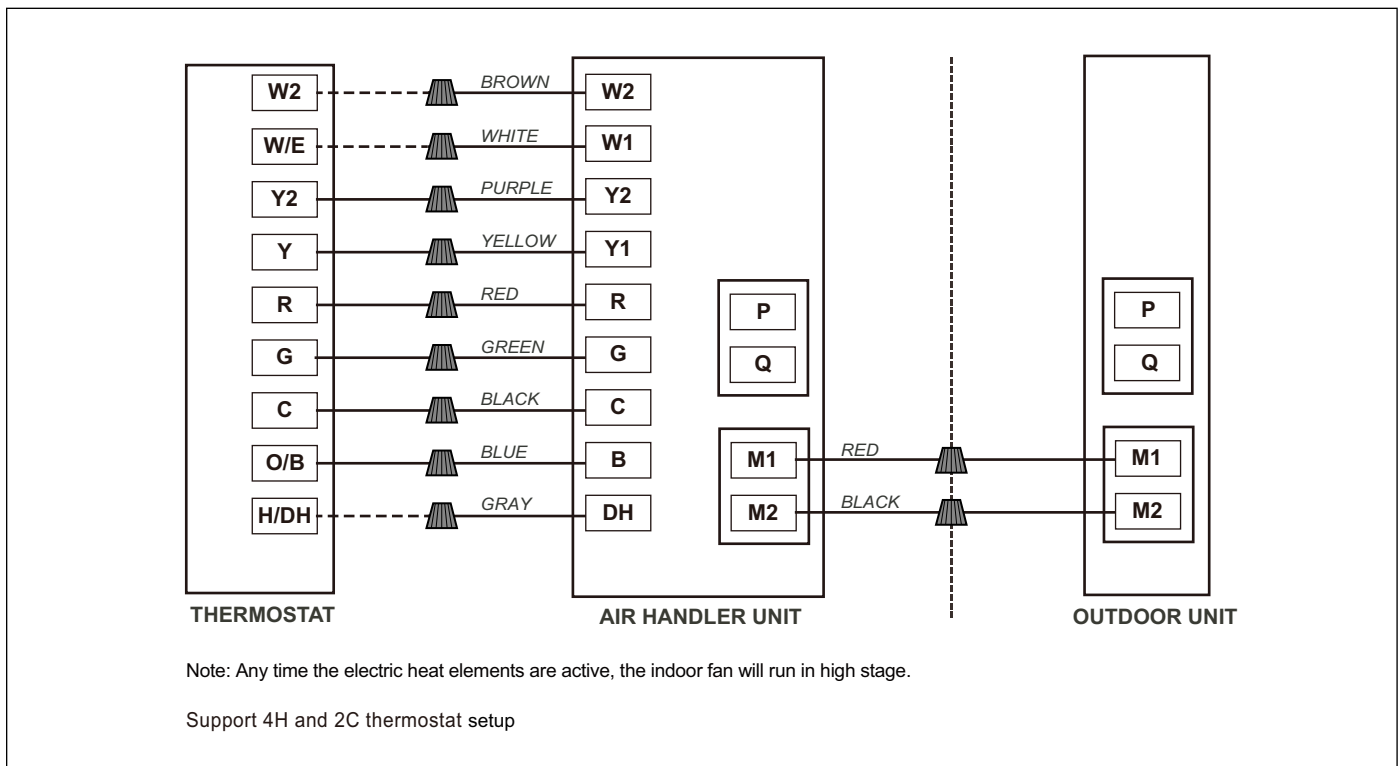

Figure 37 Control wiring for HP systems

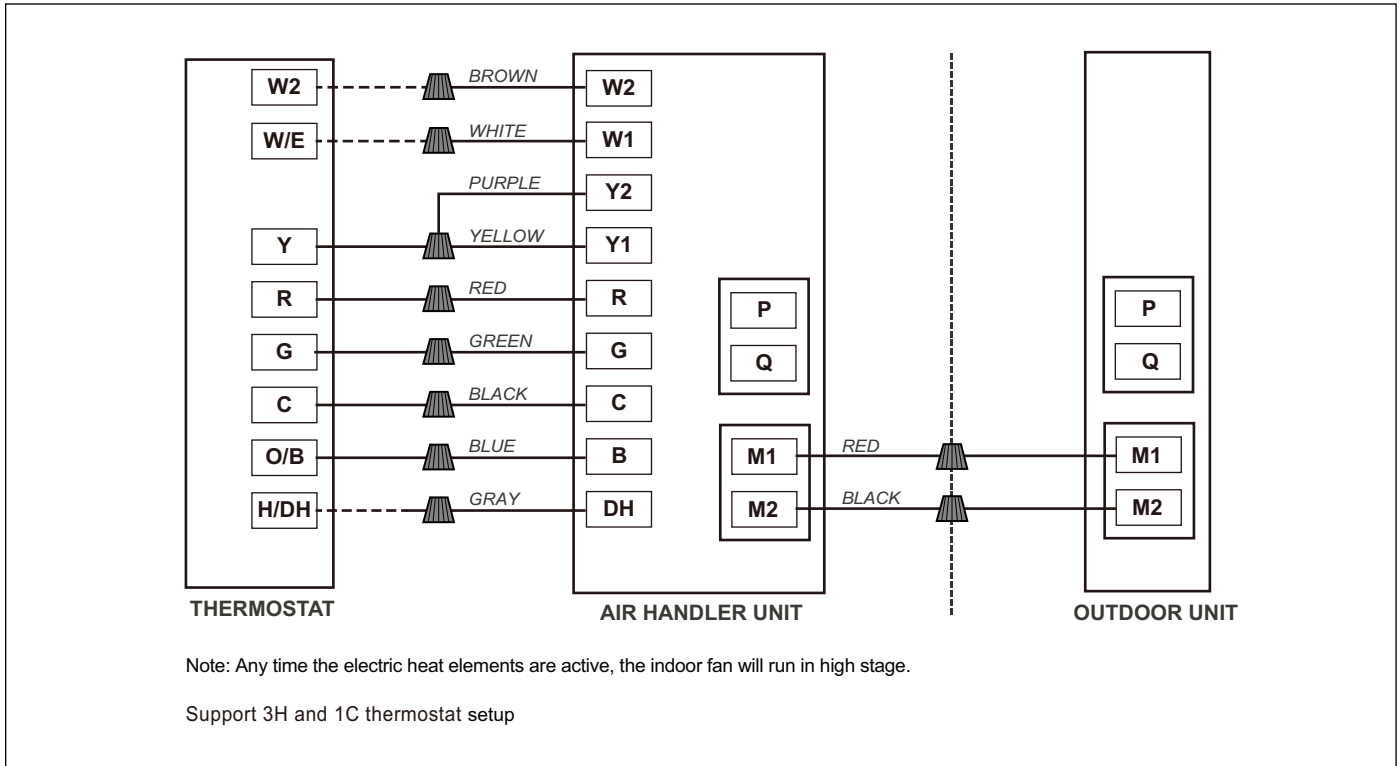

Figure 38 Control wiring for HP systems

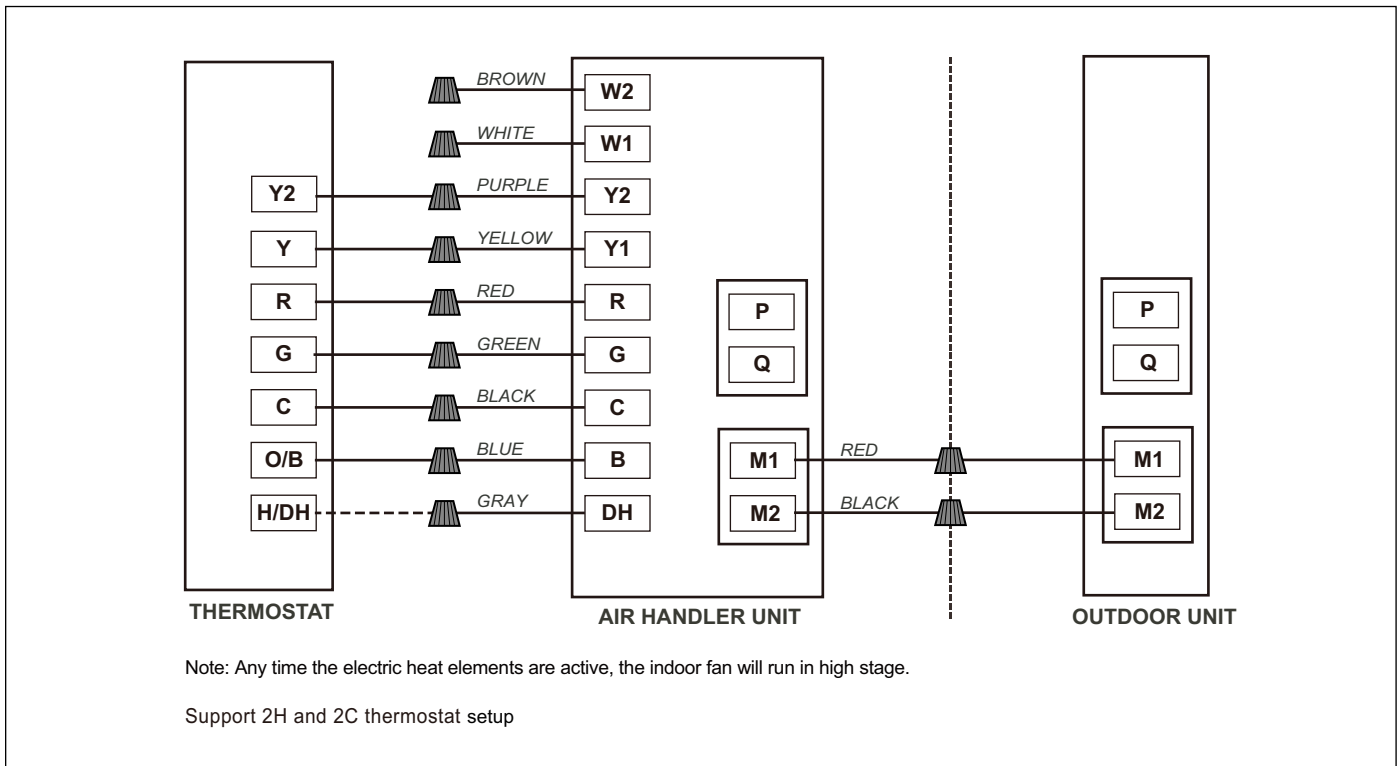

Figure 39 Control wiring for HP systems

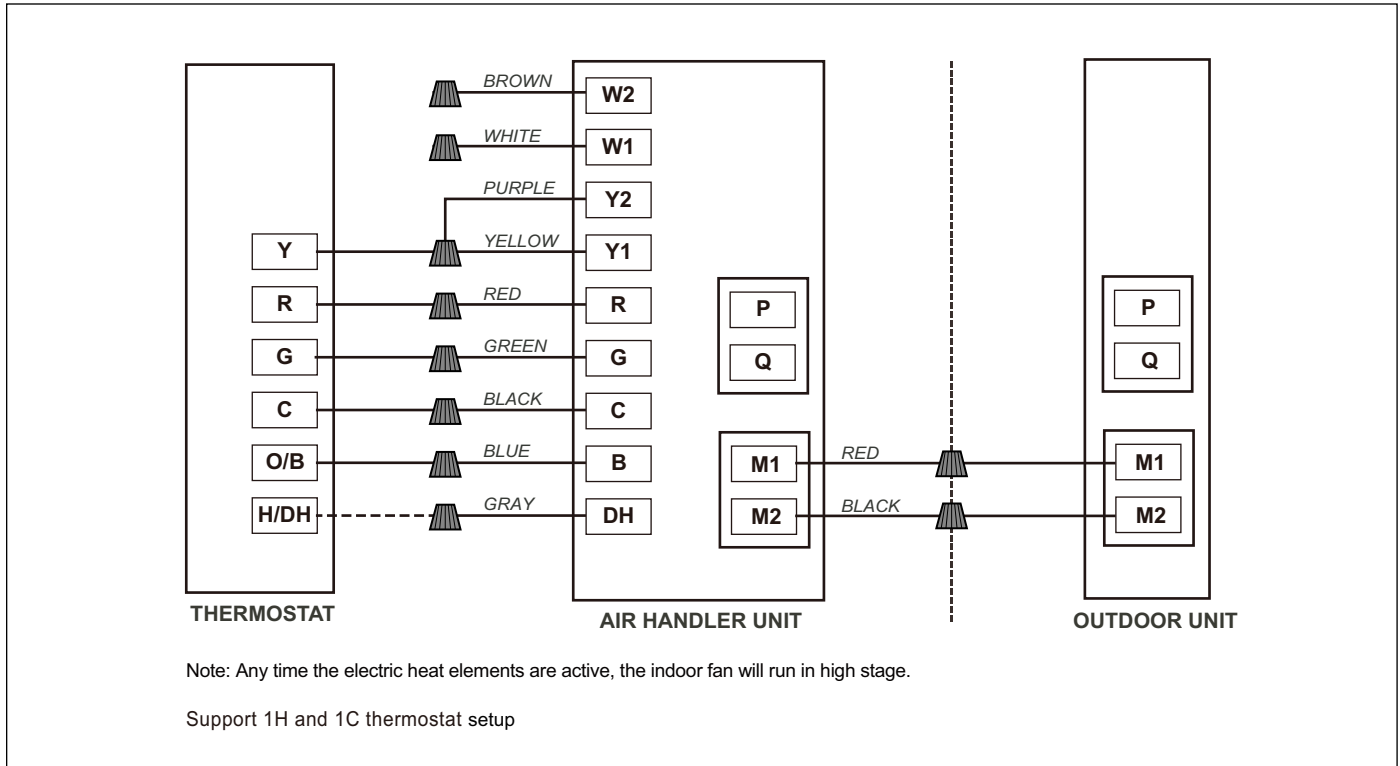

Figure 40 Control wiring for HP systems

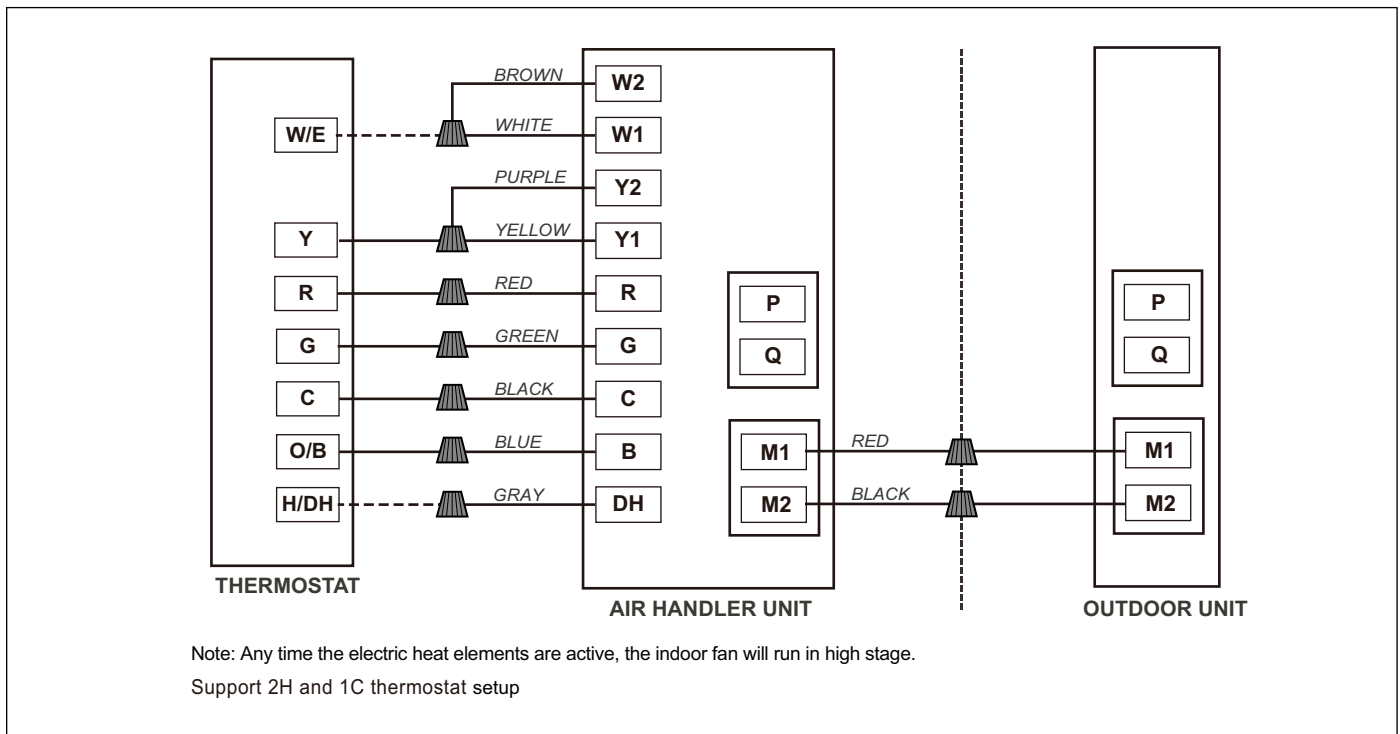

Figure 41 Control wiring for HP systems

When the Outdoor Unit is installed with a Bosch RevC 96% Furnace or 97% Furnace, please see the wiring diagram below, example wiring with 2 stage Dual Fuel configuration:

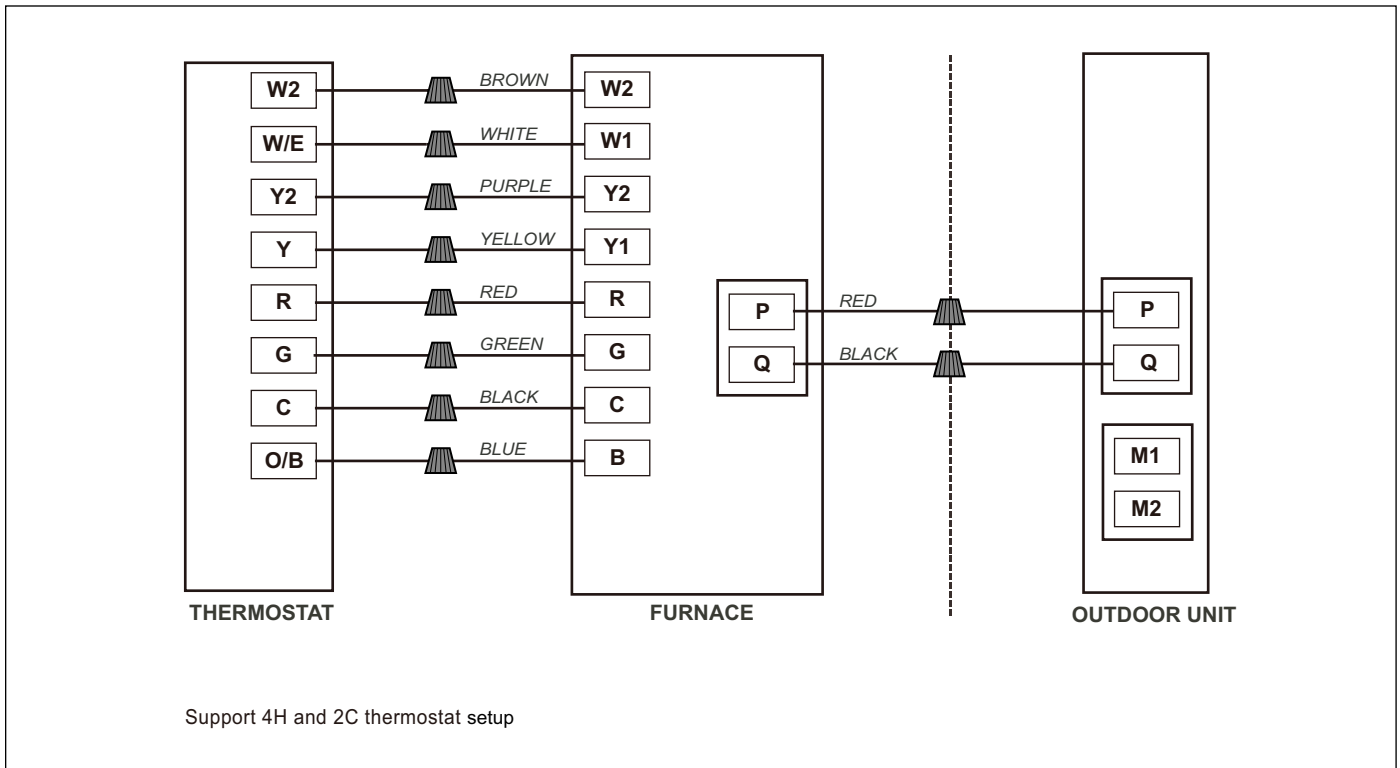

Figure 42

When the Outdoor Unit is installed with an IDS Communication Accessory Kit, please see the wiring diagrams below:

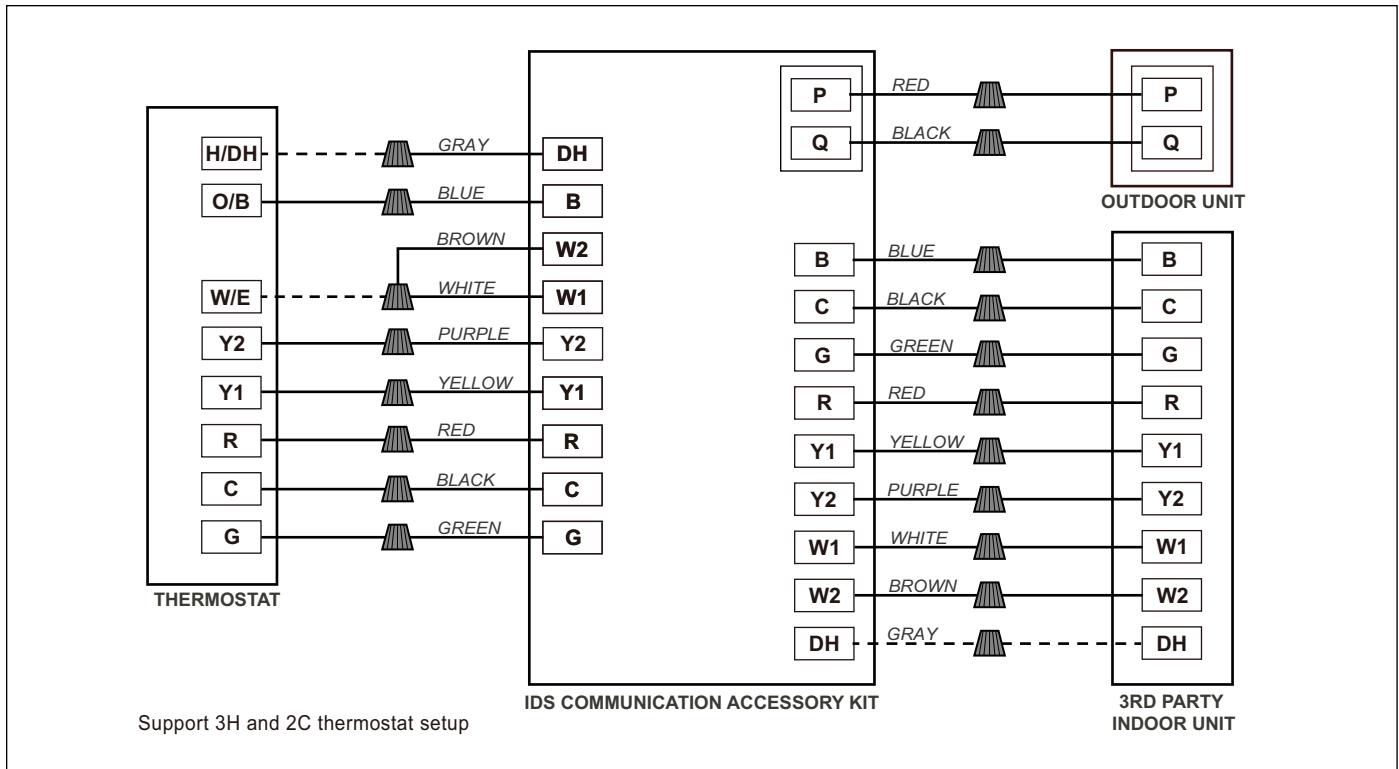

Figure 43 Control wiring for IDS Communication Accessory Kit

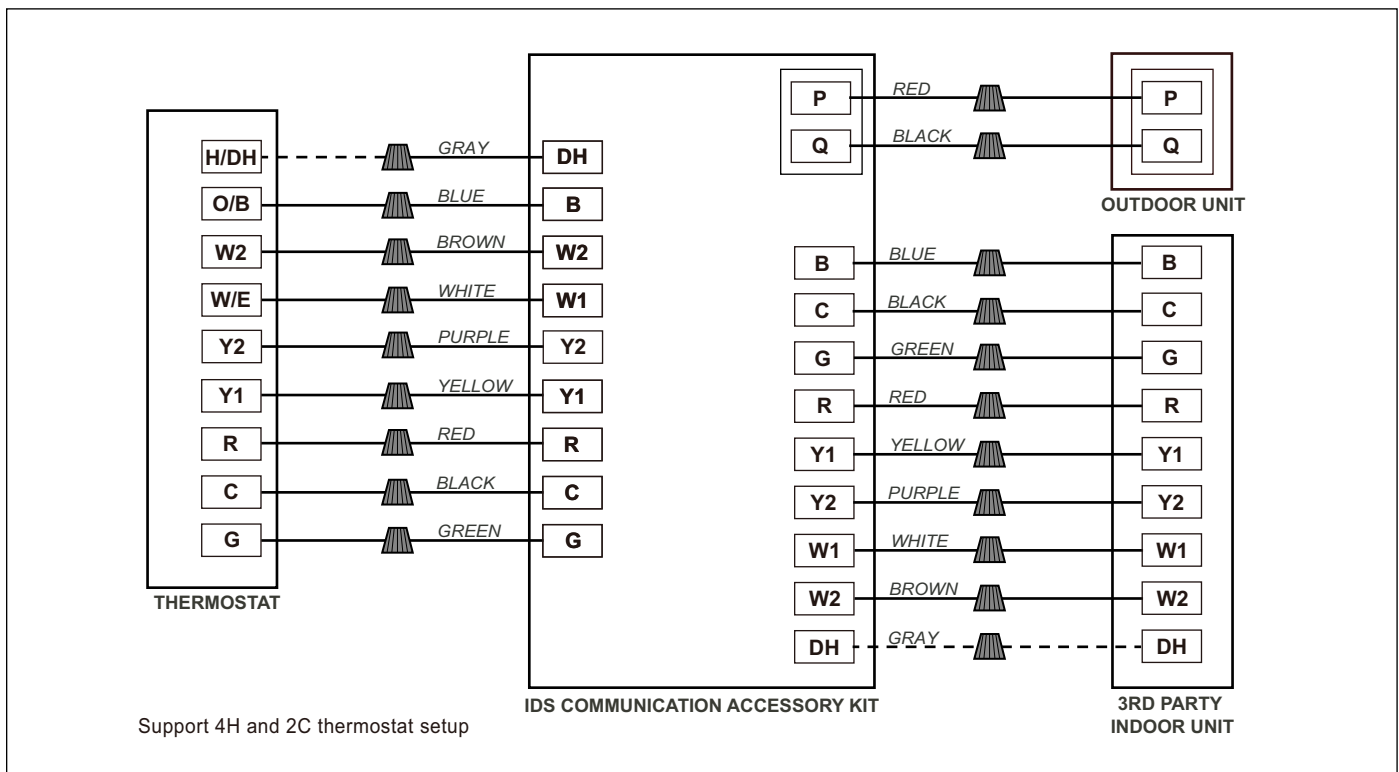

Figure 44 Control wiring for IDS Communication Accessory Kit

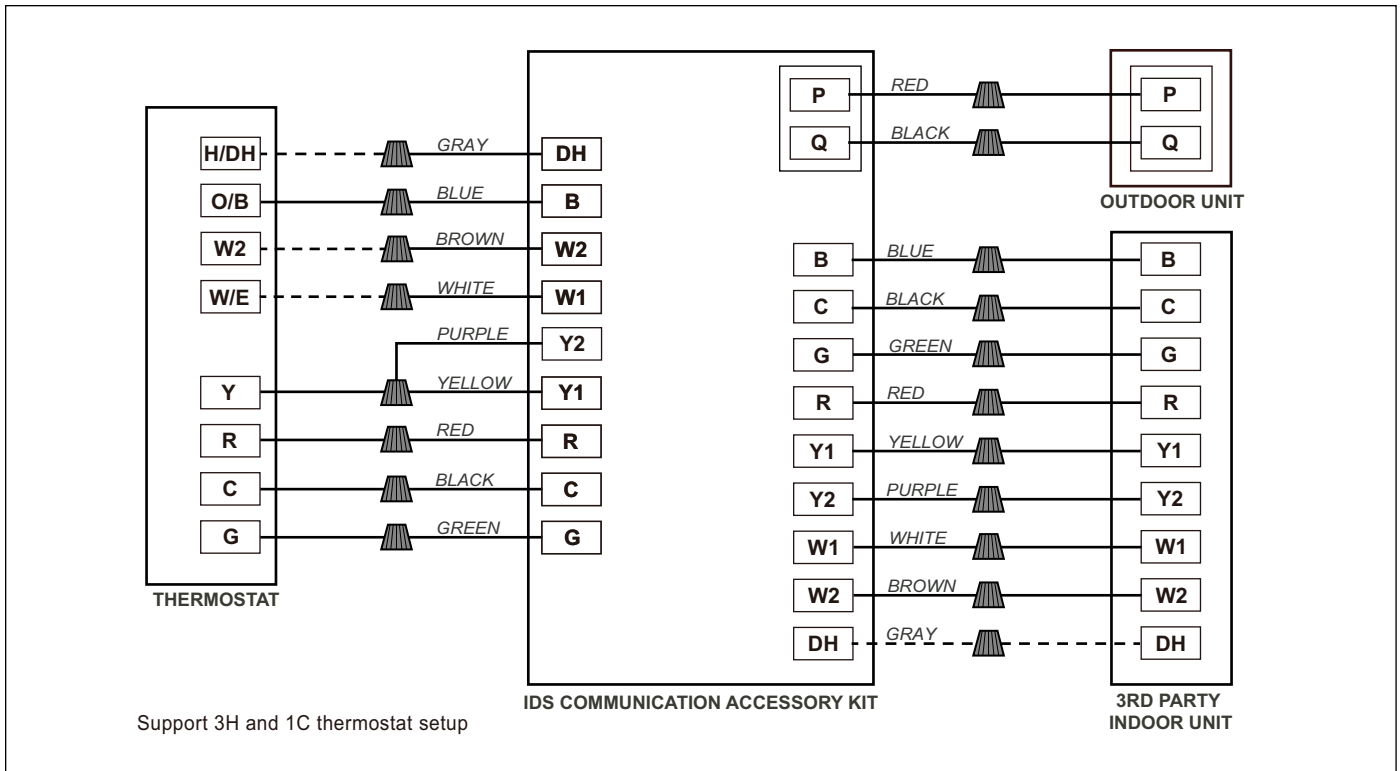

Figure 45 Control wiring for IDS Communication Accessory Kit

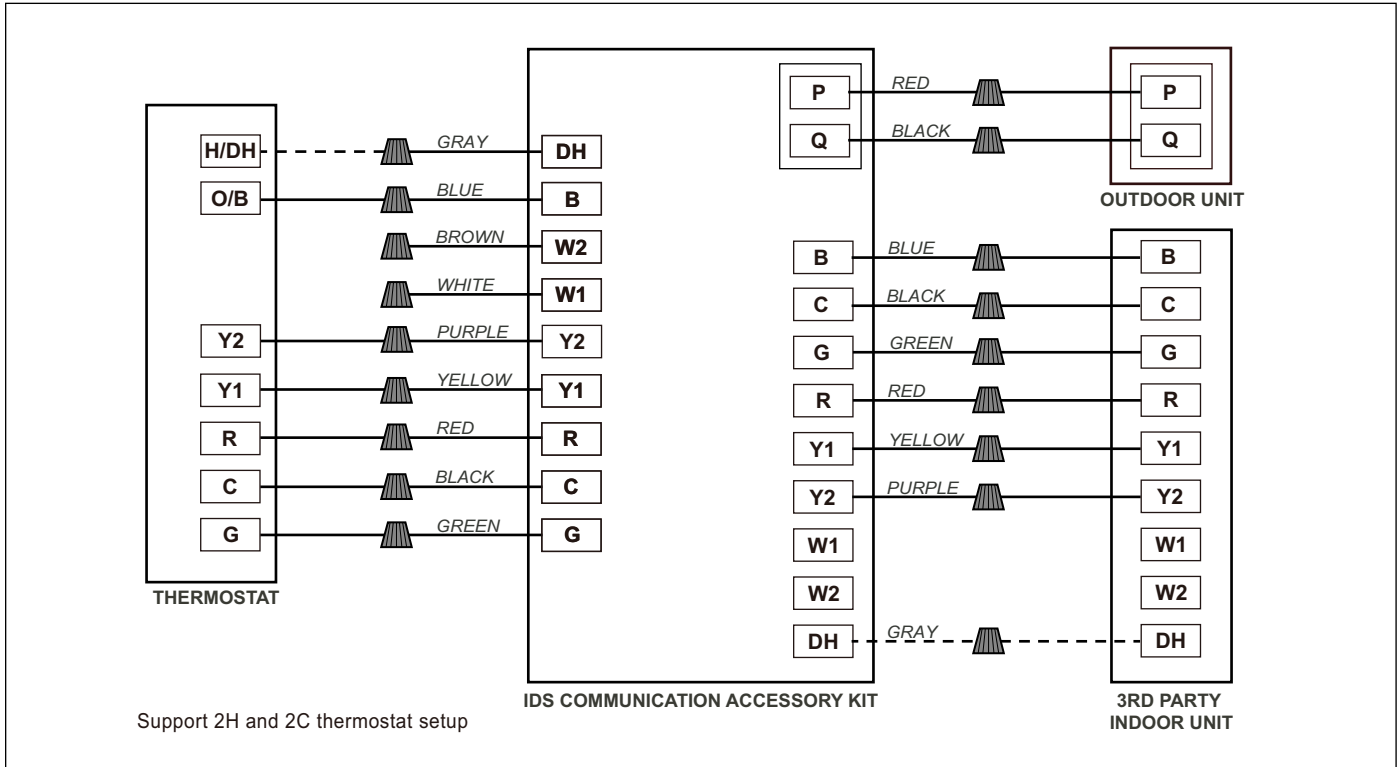

Figure 46 Control wiring for IDS Communication Accessory Kit

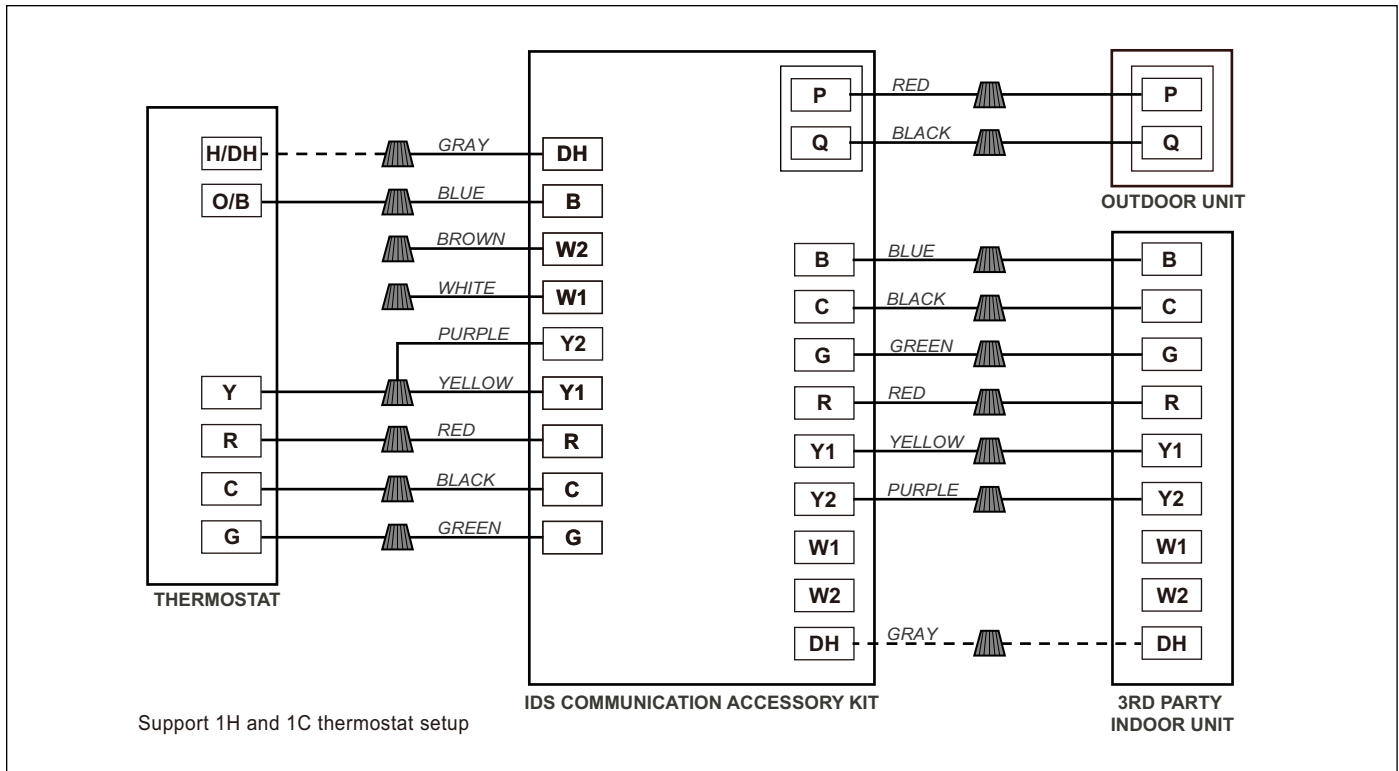

Figure 47 Control wiring for IDS Communication Accessory Kit

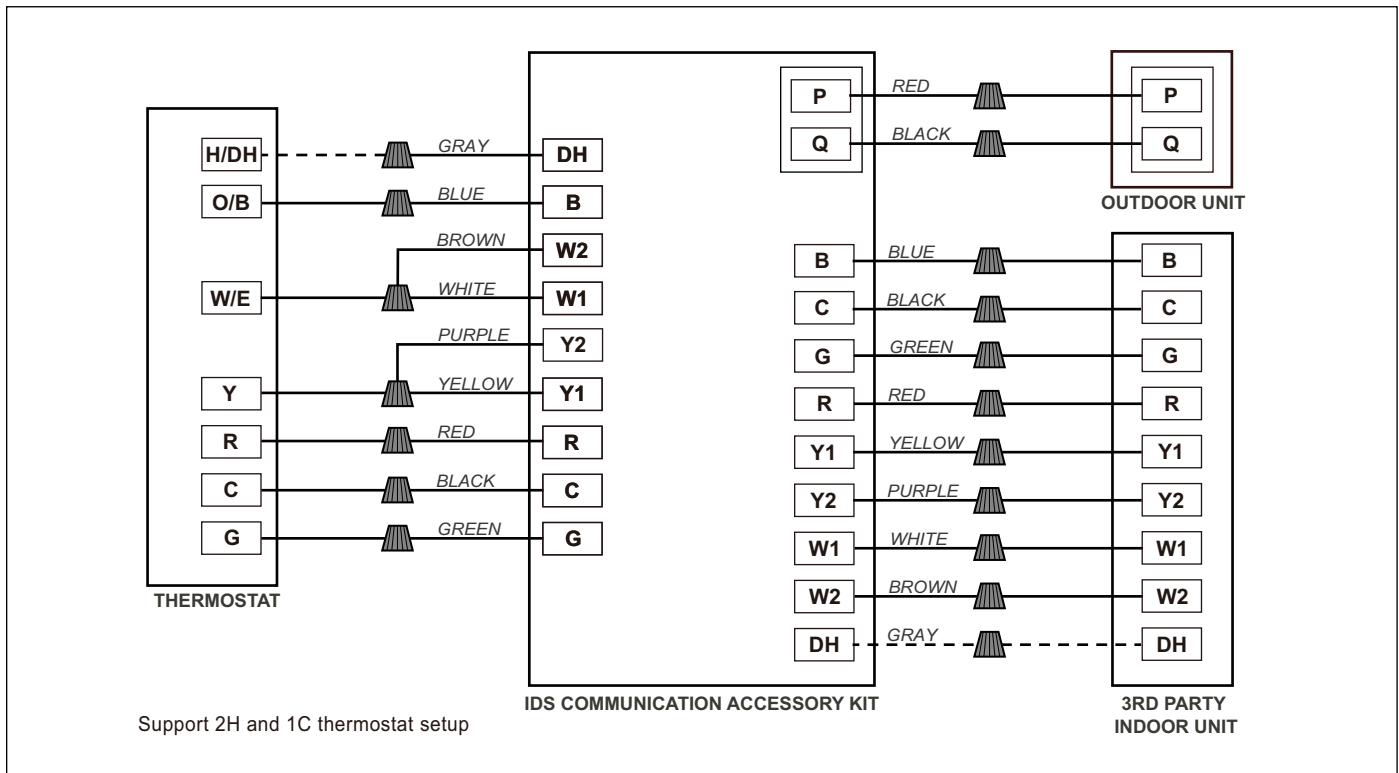

Figure 48 Control wiring for IDS Communication Accessory Kit

**NOTICE**

**Product damage!**

Do not cross-connect Hyper-Link (M1 M2) communication terminal and P Q communication terminal. This can cause damage to the control board. Please see Figure 49 below for reference.

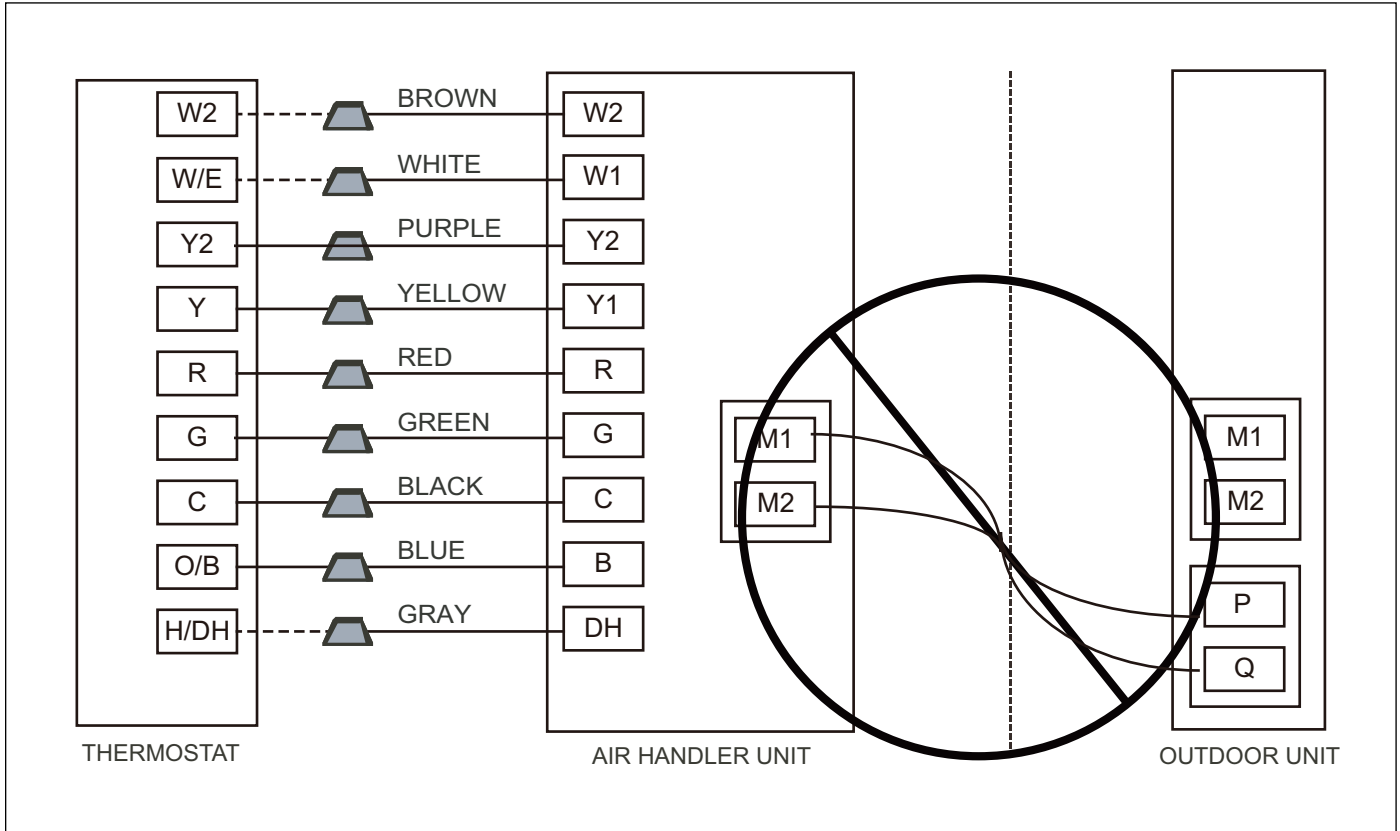

Figure 49

## 14 Electrical - High Voltage

### 14.1 High Voltage Power Supply



**WARNING**

**Live electrical components!**

During installation, testing, servicing, and trouble shooting of this product, it may be necessary to work with live electrical components. Failure to follow all electrical safety precautions when exposed to live electrical components could result in death or serious injury.

The high voltage power supply must match the equipment nameplate (208/230V, 1PH, 60Hz).



Power wiring must comply with national, state, and local codes.

Follow instructions on unit wiring diagram located on the inside of the control box access panel and refer to wiring diagram in this IOM.

### 14.2 High Voltage Disconnect Switch

Install a separate disconnect switch at the outdoor unit.  
Field supplied flexible electrical conduit must be used for high voltage wiring.

It is recommended to install an appropriate surge protection device to safeguard the unit and other electrical components in the event of power surge

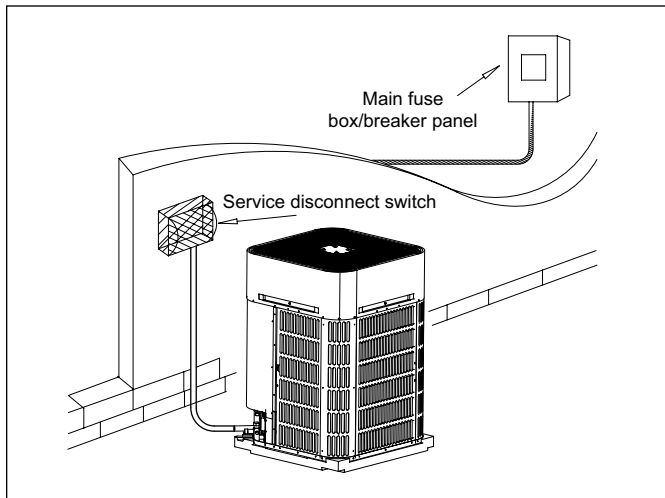

Figure 50 High voltage disconnect switch

### 14.3 High Voltage Ground

Ground the outdoor unit per national, state, and local code requirements.

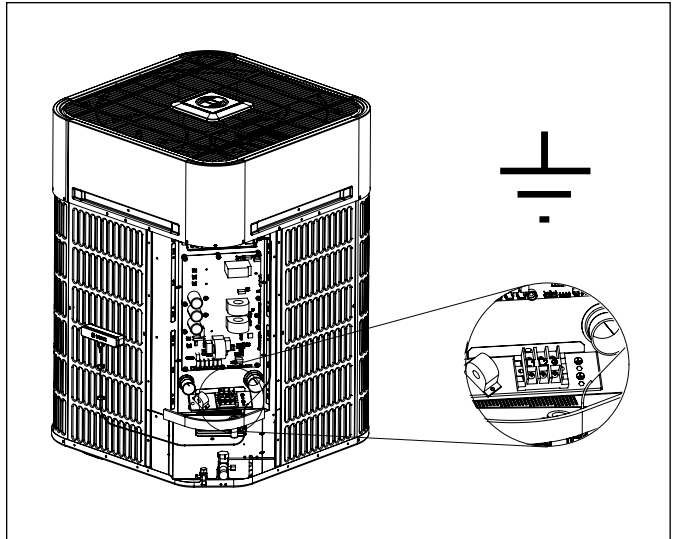

Figure 51 High voltage ground

### 14.4

## 15 Unit Type Selection

Select the appropriate tonnage to allow the unit to operate in the range of compressor and fan speeds that is optimized for best unit performance and efficiency.

For the BOVB19-60 model, if the intended capacity for the application is 5 Ton, then no change is required. For the BOVB19-60 model, if the intended capacity for the application is 4 Ton, the "J2" DIP switch must be configured to "OFF". For the BOVB19-36 model, the "J2" DIP switch must remain "ON."

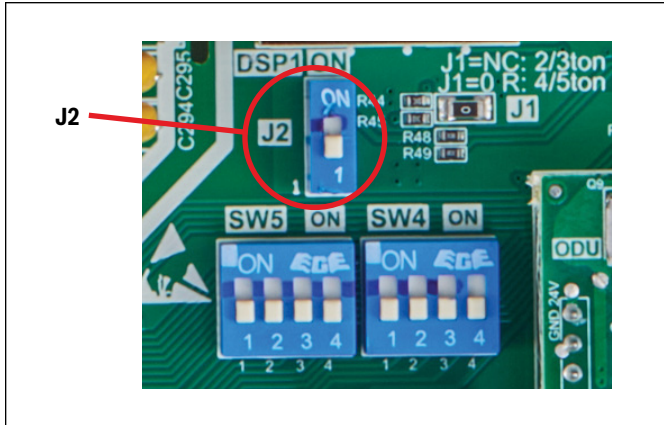

Figure 52

J2 Dip Switch	Capacity
ON	3/5 Ton*
OFF	4 Ton

Table 12

\* Factory Default



Unit must be power cycled after a DIP switch change for it to take effect.

## 16 Start Up

### 16.1 System Start Up

1. Ensure Sections 8-15 have been completed.
2. Set System Thermostat to OFF.

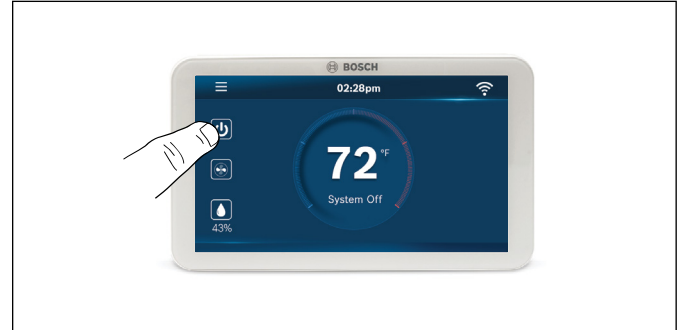

Figure 53

3. Turn on disconnect to apply power to the indoor and outdoor units.

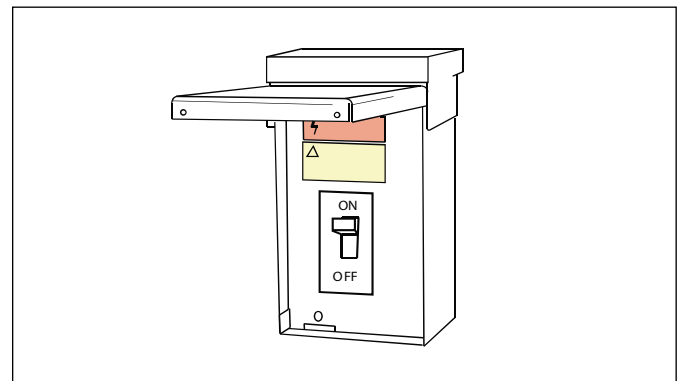

Figure 54

4. Once power is supplied to the outdoor unit, LEDs on the Gateway will turn on.



Figure 55



A LED sequence may flash on gateway for up to 6 minutes if there is a firmware update.

5. Launch the Bosch EasyAir App and access "Monitoring & Diagnostic" from the Home Page (Figure 56).

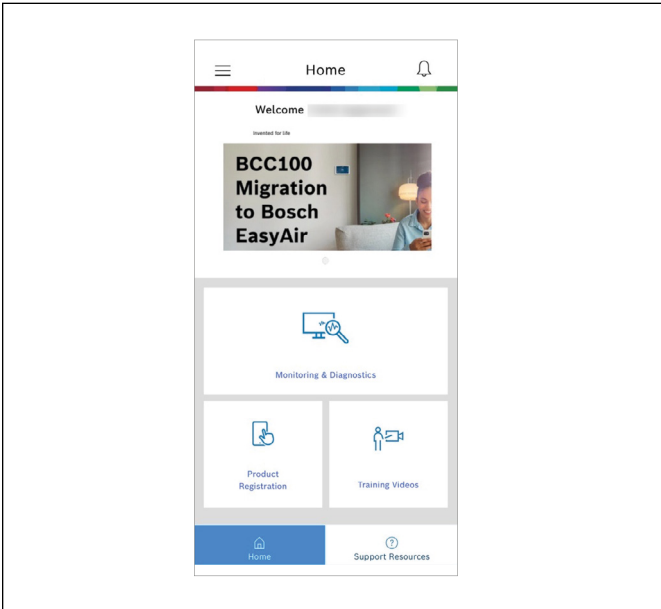

Figure 56

6. Select "Add new Unit" and follow on screen steps that includes scanning the outdoor unit serial number and gateway QR code (Figure 57).

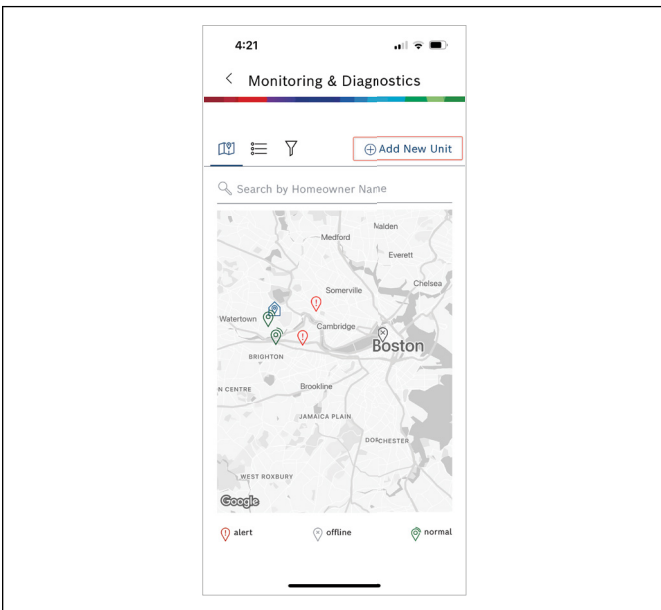

Figure 57

7. Once the heatpump has been added, access the "Remote Request" tab via the "Unit Dashboard" to associate it to the homeowner (Figure 58).

Refer to the "[EasyAir App Contractor User Manual](#)" to learn more.



The heat pump can be accessed by a Homeowner only if the contractor associates it to the homeowner via 'Remote Request' tab

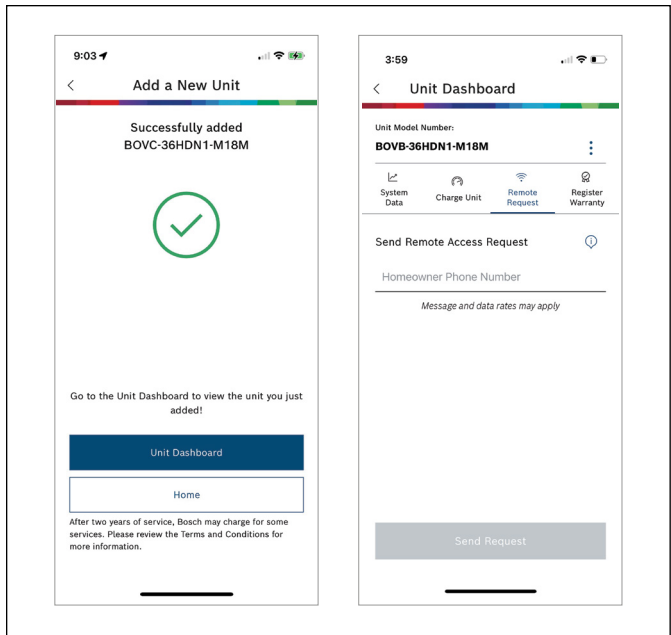

Figure 58



Steps 5-7 are required if homeowner wishes to enable Demand Response capability on the unit.

8. Upon initial unit installation, wait one (1) hour before starting the unit if compressor crankcase heater is used and the outdoor ambient temperature is below 70 °F.

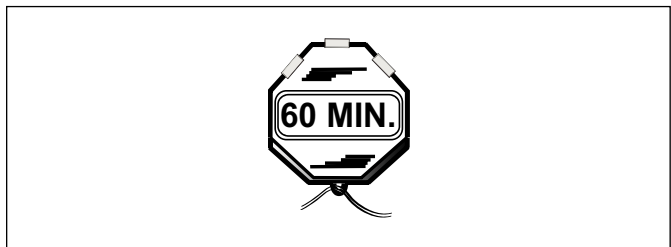

Figure 59

9. Set system thermostat to ON.



Figure 60

**16.2 Communication with BCC100/BCC110 (Recommended)**

When using Hyper-Link (M1 M2) or PQ communication mode and the system is controlled by a BCC100/BCC110, the homeowner should pair the BCC100/BCC110 with the outdoor unit via the Bosch EasyAir App for optimal system control.

1. Ensure homeowner adds the BOVB19 outdoor unit and the BCC100/BCC110 thermostat to their profile on the Bosch EasyAir App.



The heat pump can be accessed by a Homeowner only if the contractor associates it to the homeowner via 'Remote Request' tab.

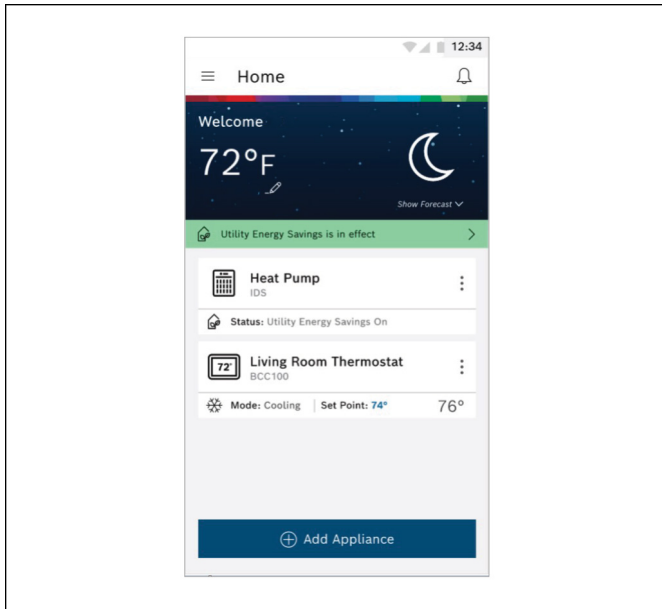

Figure 61

2. Once the thermostat and outdoor unit have been added to the GoTemp Home App, the homeowner will be prompted if they'd like to pair the two appliance. This can also be managed via the "Appliance Pairing" Setting accessed with via the Appliance Dashboard on the GoTemp Home App.



The appropriate thermostat is the one providing the unit with the 24V signals.



For multi-zone applications, multiple thermostats can be paired to the same outdoor unit.

## 17 System Charge Adjustment



Download and install the Bosch EasyAir app to assist in charging the unit.



Figure 62

### 17.1 Charging: Weigh-In Method

Use weigh-in method the initial installation, or anytime a system charge is being replaced. Weigh-in method can also be used when power is not available to the equipment site or operating conditions (indoor/outdoor temperatures) are not in range to verify with the subcooling charging method.

Model	Factory Charge	Charge multiplier for interconnecting refrigerant tube length
3 Ton	8 lbs 6 oz	0.59 oz/ft
4/5 Ton	10 lbs 14 oz	

Table 13



The factory charge in the outdoor unit is sufficient for 25 feet of standard size interconnecting liquid line.

#### New Installations—Calculating charge adjustment

- Total Line Length (ft) = \_\_\_\_\_(a)
- Standard Lineset (ft) = 25 (b)
- (a) minus (b) = \_\_\_\_\_(c)
- Refrigerant Multiplier = 0.59 oz/ft (d)
- Refrigerant Adder (c\*d) = \_\_\_\_\_(e)\*

\*If lineset is less than 25ft, (e) < 0, recover refrigerant from the system. If lineset is less than 15ft, only recover 6oz of refrigerant from the system.

#### Sealed-System Repairs—Calculating total system charge.

- Total Line Length (ft) = \_\_\_\_\_(a)
- Standard Lineset (ft) = 25 (b)
- (a) minus (b) = \_\_\_\_\_(c)
- Refrigerant Multiplier = 0.59 oz/ft (d)
- Refrigerant Adder (c\*d) = \_\_\_\_\_(e)\*
- Factory Charge (namplate) = \_\_\_\_\_(f)
- Total System Charge (e+f) = \_\_\_\_\_

\* If lineset is less than 25ft, (e) < 0, recover refrigerant from the system. If lineset is less than 15ft, only recover 6oz of refrigerant from the system.



The only mode approved for validating system charge is while in Cooling "Force Mode". Outdoor temperature must be between 55°F and 120°F with indoor temperature kept between 70°F and 80°F.

### 17.2 Subcooling Charging And Refrigerant Adjustment In Cooling (Above 50°F Outdoor Temp.)

- Check the outdoor ambient temperatures.

Subcooling (**in cooling mode**) is the only recommended method of charging above 50°F outdoor ambient temperatures.

For outdoor ambient temperatures below 50°F use weigh-in charge method.



It is important to return in the spring or summer to accurately charge the system in the cooling mode when outdoor ambient temperature is above 50°F.

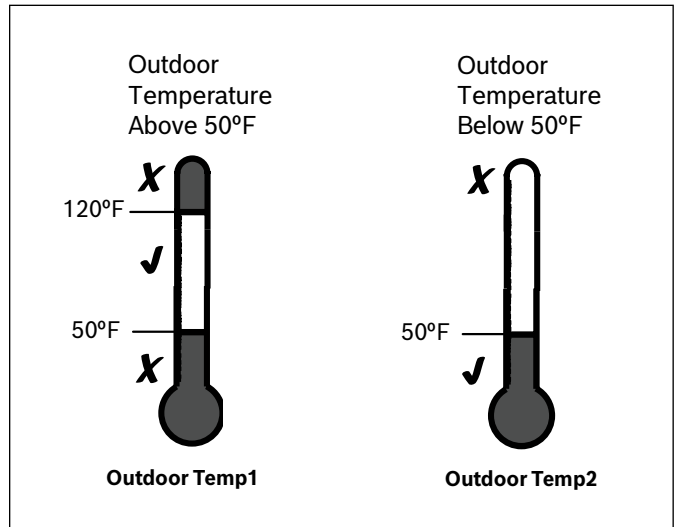

Figure 63

For best results, the indoor temperature should be kept between 70°F and 80°F during the install.

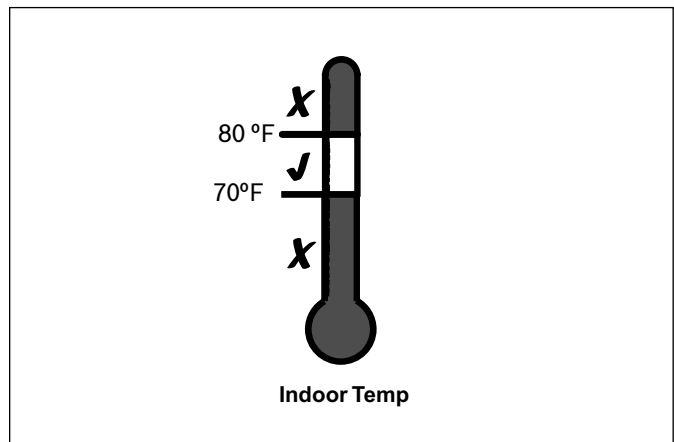

Figure 64

2. Ensure Sections 8 -16 have been completed.
3. Stabilize the system.

After **starting the system in cooling mode**, short press “FORCE” button, and “+” symbol should appear. System may take 10 minutes to ramp up. Operate the system for a minimum of twenty (20) minutes.



After a twenty (20) minute stabilization period (i.e. once the compressor reaches the frequency shown in Table 14), maintain continuous operation while adjusting refrigerant charge. After adjusting, operate system for a minimum of five (5) minutes for stabilization, otherwise repeat step 3.

Force mode frequency	3T	4T / 5T	Remark
Cooling	46	60	Charge mode

Table 14

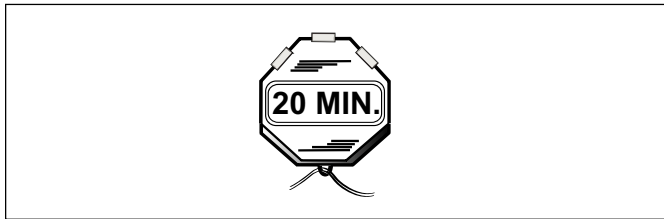

Figure 65

4. Calculate superheat value (According to Table 15)
  - Measured Suction Line Temp = \_\_\_\_\_°F
  - Measured Suction Line Pressure = \_\_\_\_\_ PSIG
  - Calculate superheat value = \_\_\_\_\_°F



Check the superheat and select correct subcooling according to superheat, refer to Table 17. It is recommended to keep the superheat at 10-18°F if a third party indoor unit is used.

5. Calculate subcooling value (According to Table 16)
  - Measured Liquid Line Temp. = \_\_\_\_\_°F
  - Measured Liquid Line Pressure = \_\_\_\_\_ PSIG
  - Calculate subcooling value = \_\_\_\_\_°F

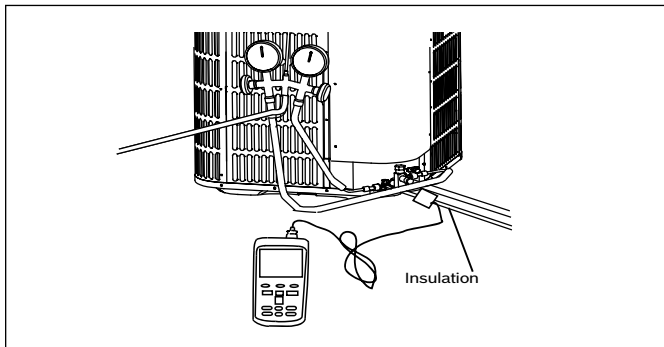

Figure 66



If calculated subcooling value is lower than the design subcooling value (Table 17), please add refrigerant. Repeat steps 3 through 5.



To exit force mode, press the force button again for 1 second.



If the superheat is out of range, refer to Troubleshooting section of this IOM.

Suction Temp [°F]	Final Superheat - °F									
	6	8	10	12	14	16	18	20	22	
	Suction Gauge Pressure (PSIG)									
40	95	91	87	84	80	77	74	70	67	
42	99	95	91	87	84	80	77	74	70	
44	103	99	95	91	87	84	80	77	74	
46	107	103	99	95	91	87	84	80	77	
48	111	107	103	99	95	91	87	84	80	
50	116	111	107	103	99	95	91	87	84	
52	120	116	111	107	103	99	95	91	87	
54	125	120	116	111	107	103	99	95	91	
56	129	125	120	116	111	107	103	99	95	
58	134	129	125	120	116	111	107	103	99	
60	139	134	129	125	120	116	111	107	103	
62	144	139	134	129	125	120	116	111	107	
64	149	144	139	134	129	125	120	116	111	
66	155	149	144	139	134	129	125	120	116	
68	160	155	149	144	139	134	129	125	120	
70	166	160	155	149	144	139	134	129	125	
72	171	166	160	155	149	144	139	134	129	

Table 15 R-454B Refrigerant chart - Final Superheat

Liquid Temp [°F]	Final Subcooling - °F								
	6	7	8	9	10	11	12	13	
	Liquid Gauge Pressure (PSIG)								
55	164	167	170	172	175	178	181	184	
60	178	181	184	187	191	194	197	200	
65	194	197	200	203	206	210	213	217	
70	210	213	217	220	223	227	230	234	
75	227	230	234	238	241	245	249	252	
80	245	249	252	256	260	264	268	272	
85	264	268	272	276	280	284	288	292	
90	284	288	292	297	301	305	309	314	
95	305	309	314	318	323	327	332	336	
100	327	332	336	341	346	351	355	360	
105	351	355	360	365	370	375	380	385	
110	375	380	385	390	396	401	406	412	
115	401	406	412	417	422	428	433	439	
120	428	433	439	445	450	456	462	468	
125	456	462	468	474	480	486	492	498	

Table 16 R-454B Refrigerant chart - Final Subcooling

Model	Design Subcooling	
	Subcooling/°F	Superheat/°F
3 Ton	6-10*	7-13*
	8-12	10-18
4/5 Ton	4-8*	7-13*
	6-10	10-18

Table 17

\* Optimized range for superheat/subcool

- Adjust refrigerant level to attain proper gauge pressure.



**Add refrigerant** if the subcooling reading from Table 16 is lower than the designed value (Table 17).

- Connect gauges to refrigerant bottle and unit as illustrated (Figure 68).
- Purge all hoses.
- Open tank.
- Stop adding refrigerant when subcooling matches the design value (Table 17).



**Recover refrigerant** if the subcooling reading from Table 16 is higher than the design value (Table 17).

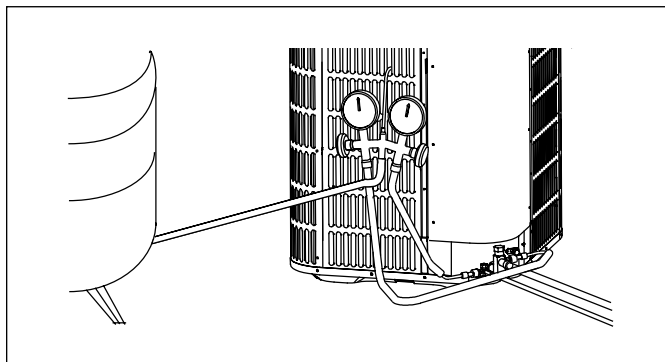

Figure 67

- Stabilize the system.
  - Wait 5 minutes for the system condition to stabilize between adjustments.



When the subcooling matches the design value (Table 17), the system is properly charged.

- Remove gauges.
- Replace service port caps to prevent leaks. Tighten finger tight plus an additional 1/6 turn.

- Record System Information for reference (Table 18).

Record system pressures and temperatures after charging is complete.

Description	Value
Outdoor model number	
Measured Outdoor Ambient	°F
Measured Indoor Ambient	°F
Measured Liquid Line Temp	°F
Measured Suction Line Temp	°F
Liquid Gauge Pressure	PSIG
Suction Gauge Pressure	PSIG

Table 18

### 17.3 Record the Refrigerant Charge Amount

After refrigerant is charged, record the amount of refrigerant to be charged on the label of the outdoor unit. **1** indicates the amount of refrigerant to be charged by the factory, **2** indicates the additional refrigerant, and **1 + 2** indicates the total refrigerant to be charged.

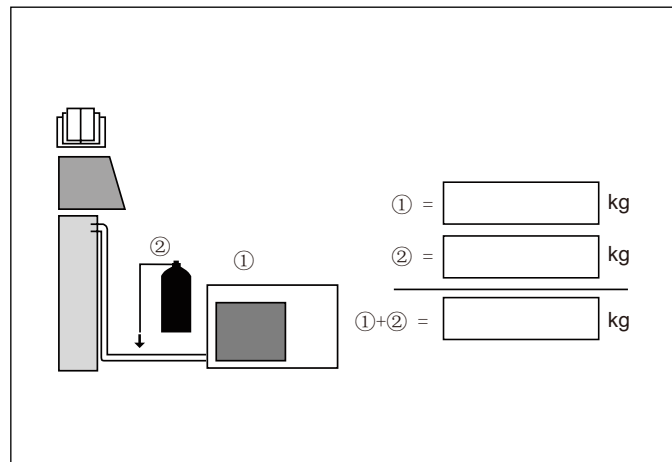

Figure 68

## 18 System Operation and Troubleshooting



Download and install the Bosch EasyAir app to assist in troubleshooting the unit.



Figure 69

### 18.1 Control Logic Description

- The compressor's speed is controlled based on coil pressures monitored by the unit's pressure transducer. To ensure stable and adequate capacity, the compressor speed will modulate relative to evaporator pressure during cooling operation and relative to condensing pressure during heating operation. The target pressure can automatically adjust based on compressor operation so optimal capacity can be achieved. Target pressure can be manually adjusted (SW4) to achieve improved dehumidification and capacity demands.

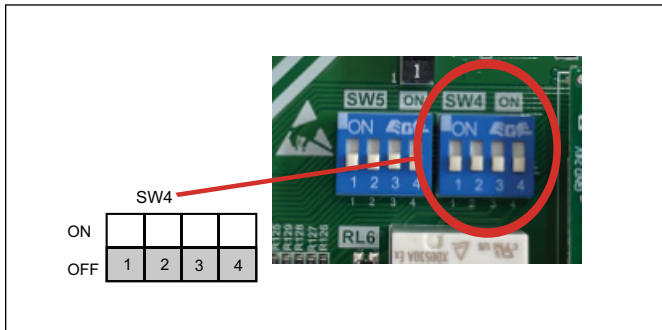

Figure 70

Switch		Description
SW4-1	ON	Unused
	OFF*	Must be set at "OFF" position
SW4-2	ON	Accelerated cooling/heating 1
	OFF*	Normal cooling/heating
SW4-3	ON	Accelerated cooling/heating 2
	OFF*	Normal cooling/heating
SW4-4	ON	Adaptive capacity output disabled
	OFF*	Adaptive capacity output enabled

Table 19

\*Factory Default

- Adaptive capacity function is a "self-learning function" which allows a range of target coil temperatures to adapt for better unit operation and reduced short cycling.
- Accelerated cooling/heating function changes the initial target coil temperature to provide "enhanced comfort" by increasing unit capacity.

### 18.2 Sensors (Thermistors/Pressure Transducer)

- T3 = Outdoor Coil Temperature (Table 24)
  - High/Low temperature protection
  - Outdoor fan control (cooling mode)
  - Defrost control (heating mode)
- T4 = Ambient Temperature (Table 24)
  - Operating condition permission
  - Defrosting condition permission
  - Outdoor fan control (heating mode)
- T5 = Compressor Discharge Temperature (Table 25)
  - High/Low temperature protection
  - Electronic Expansion Valve (EEVA) (ODU/heating mode only)
- Th = Compressor Return Temperature (Table 24)
- T3L = Liquid Line Temperature (Table 24)
- T6A = Temperature at inlet of plate heat exchanger Electronic Expansion Valve Control (EEVC) (ODU/heating mode only) (Table 24)
- T6B = Temperature at outlet of plate heat exchanger Electronic Expansion Valve Control (EEVC) (ODU/heating mode only) (Table 24)
- T7 = Liquid Service Valve Temperature Accurate subcooling measurements (Table 24)
- Pc = Condensing Pressure Transducer
  - Compressor frequency control
  - High pressure protection (cooling mode)
  - Low pressure protection (heating mode)
- Pe = Evaporating Pressure Transducer
  - Compressor frequency control
  - Electronic Expansion Valve (EEVA) control (heating mode only)
  - High pressure protection (heating mode)
  - Low pressure protection (cooling mode)
  - Outdoor unit current sensor -measures total outdoor unit power consumption

### 18.3 Pressure Equalizer Valve (PEV/SV5)

Used to balance the pressure in the system before compressor start up.

### 18.4 Defrost Description

- The Demand Defrost Control (DDC) monitors the ODU coil temperature using thermistor (T3). A second thermistor (T4) monitors outdoor ambient temperature. Based on these parameters, as well as accumulative run time and high pressure, the DDC calculates proper initiation of defrost.
- Any one of the below three conditions is required to enter defrost:
  - The calculated temperature difference between the outdoor temperature (T4) and the coil temperature (T3) is called Delta T. Defrost is initiated after Delta T is achieved and continues for 3 minutes.
    - T4 ≥ 39°F, Delta T = 18°F
    - T4 ≥ 30°F, Delta T = 16°F
    - T4 ≥ 19°F, Delta T = 14°F
    - When T4 < 19°F, T3 < 9°F, accumulated compressor run time ≥ 95 minutes.
  - After "Minimum Run Time" (MRT) is achieved. MRT is based on outdoor ambient temperature (T4), for example:
    - MRT is 4 hours when: T4 < 23°F
    - MRT is 2 hours when: 23°F ≤ T4 < 42°F
    - MRT is 50 minutes when the previous defrost duration was at least 8 minutes

3. After the high pressure saturation temperature drops below 82°F for 20 minutes and  $14^{\circ}\text{F} \leq T_4 < 29^{\circ}\text{F}$ .
- Defrost will terminate once outdoor coil temperature (T3) reaches 64°F for a period of 1 minute or defrost time has exceeded 8 minutes.
  - Defrost Termination Settings (SW5) offers different defrost termination options for enhanced defrost for different geographical and outdoor conditions.

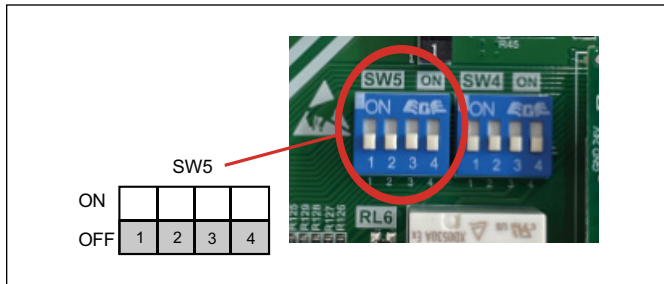

Figure 71

DIP Switch	Description	
SW5-1	ON	Heating time reduced 10%
	OFF*	Normal
SW5-2	ON	Defrosting extended for 60 seconds
	OFF*	Normal
SW5-3	ON	Unused
	OFF*	Normal
SW5-4	ON	Reserved
	OFF*	Communicating Mode

Table 20

\* Factory Default

- Manual Defrost:
  1. System must have a call for heat and have been operating for a minimum of 8 minutes.
  2. Press “Force” button on inverter board for 6 seconds to begin forced defrost.
  3. Wait approximately 40 seconds for defrost to initiate.
  4. Once defrost initiates, the display will indicate “dF”.
  5. Defrost test will terminate automatically, after which the display will indicate running speed.
  6. If a second defrost test is required, repeat steps 2-5 after 5 minutes.



Unit must be power cycled after a DIP switch change for it to take effect.

### 18.5 Compressor Crankcase Heater Description

Refrigerant migration during the OFF cycle can result in noisy start-ups, therefore a CrankCase Heater (CCH) is used to minimize refrigerant migration thereby minimizing start-up noise and/or bearing “wash out”. All CCHs must be installed on the lower half of the compressor shell. Its purpose is to warm the compressor during the OFF cycle, driving refrigerant from compressor. After extended shutdown periods in cold weather, it is recommended to allow CCH to be energized for at least 12 hours prior to compressor operation by applying line voltage to heat pump with thermostat OFF.

- CCH operation energizes:

1. First time line voltage is applied and compressor discharge temperature  $T_5 < 53.6^{\circ}\text{F}$ .
  2. Compressor stops running for 3 hours (outdoor ambient temperature  $T_4 < 41^{\circ}\text{F}$  OR compressor discharge temperature  $T_5 < 53.6^{\circ}\text{F}$ ).
- CCH operation de-energizes:
    1. Compressor discharge temperature  $T_5 \geq 60.8^{\circ}\text{F}$ .
    2. Compressor start running.

### 18.6 Reversing Valve Operation

Reversing valve energizes during heat mode and de-energizes in cool mode. The input voltage of reversing valve is 220V.



During a heat call on first time operation the unit will run about 1 minute in cooling to build up pressure for reversing valve to change.

### 18.7 Baseplate Heater Operation

When the ambient temperature is low, the baseplate heater will be automatically turned on to prevent the baseplate from blocked by ice.

- Baseplate heater operation energizes:
  - Outdoor ambient temperature  $T_4 < 35.6^{\circ}\text{F}$  in heating model.
- Baseplate heater operation de-energizes:
  - Outdoor ambient temperature  $T_4 \geq 39.2^{\circ}\text{F}$  last more than 1 minute.
  - Switch to cooling mode

### 18.8 Protection Functions

- Outdoor coil temperature protection (T3)
  - i. If  $T_3 > 150.8^{\circ}\text{F}$ , compressor is de-energized.
  - ii. If  $T_3 < 132.8^{\circ}\text{F}$ , compressor is energized.
- Ambient temperature protection (T4)
  - i. If  $14^{\circ}\text{F} \leq T_4 < 125^{\circ}\text{F}$ , unit can operate in cooling.
  - ii. If  $-13^{\circ}\text{F} \leq T_4 < 86^{\circ}\text{F}$ , unit can operate in heating.
  - iii. If  $T_4 < -13^{\circ}\text{F}$ , heat pump will provide 24V control to indoor unit energizing electric heat (if installed).



See BOVB19 Product Specification for extended performance data.

- Discharge Temperature (DT) protection (T5)
  - i. If  $DT > 230^{\circ}\text{F}$  during cooling mode, the compressor will stop.
  - ii. If  $DT < 188.6^{\circ}\text{F}$  during cooling mode, the compressor will restart.
- High Pressure (HP) protection (mechanical open/close pressure switch)
  - i. High Pressure Switch opens at  $P > 580$  PSIG, the compressor and outdoor fan stop.
  - ii. High Pressure Switch closes at  $P < 435$  PSIG, the compressor and outdoor fan restart.
- Low Pressure (LP) protection
  - i. If Low Pressure  $< 21.8$  PSI for 5 minutes during cooling mode, the compressor and outdoor fan will stop. The system will attempt to run again after 6 minutes.
  - ii. If Low Pressure  $< 10.2$  psig for 3 seconds during heating mode, the compressor and outdoor fan will stop.
- Low discharge superheat protection
  - i. Head discharge superheat  $HDSH < 9^{\circ}\text{F}$  last 40minutes.

### 18.9 Fault Code Table

Code	Fault Description (Sensor)
AtL	Ambient Temperature Limited(T4)
b1	Temperature sensor fault in indoor unit (T1)
b2	Temperature sensor fault in indoor unit (T2)
b3	R-454B refrigerant sensor fault in indoor unit
b4	R-454B refrigerant sensor communication fault in indoor unit
b5	Communication fault between indoor unit and outdoor unit
b6	Power consumption sensor fault in indoor unit
b7	R-454B refrigerant leakage protection in indoor unit
b8	R-454B refrigerant sensor over service life in indoor unit
b9*	The furnace's refrigerant sensor dipswitch is positioned incorrectly
bF	Furnace blower control module failure
C3	The coil sensor is unplugged in cooling (T3)
E41	Temperature sensor fault (T3)
E42	Temperature sensor fault (T3L)
E43	Temperature sensor fault (T4)
E44	Temperature sensor fault (T5)
E45	Temperature sensor fault (Th)
E46	Temperature sensor fault (T6A)
E47	Temperature sensor fault (T6B)
E48	Temperature sensor fault (T7)
E49	Basepan heater fault
E51	Outdoor unit high/low input voltage protection
E52	Outdoor unit high/low DC bus voltage protection
E7	Compressor discharge sensor is unplugged (T5)
E81	EEVA solenoid coil fault
E82	EEVC solenoid coil fault
EA	Control program does not match drive program in outdoor unit
F1	High pressure switch fault (HPS)
F2*	5 times (P2) protection in 100 minutes, system lockout
F41	High pressure sensor fault
F42	Low pressure sensor fault
H01	Drive chip Communication fault in outdoor unit
H04	Chip of power consumption sensor communication fault in outdoor unit
H14	Power consumption sensor fault in outdoor unit
J00-JCF	Compressor drive fault
n00-nCF	Fan drive fault
P0	Compressor IPM temperature protection
P1	High pressure switch protection (HPS)
P11	High pressure protection in cooling/heating (Pc)
P21	Low pressure protection in cooling/heating (Pe)
P31	Outdoor unit over current protection
P32	Compressor over current protection
P4	High compressor discharge temperature protection (T5)
P5	Condensor coil temperature protection in cooling (T3)
Pb1	Hyper-Link (M1 M2) over current protection
PH	Low discharge superheat protection

Table 21

\* Fault requires hard restart

### 18.10 System Protection Status Codes

Code	Description
888	Forced operation mode
888	Running indication under high pressure
888	Running indication under low pressure
888	Running indication under return oil mode
888	Running indication under current limited condition
888	Running indication under T5 limited condition
888	Running indication under COMP. IPM Temp. limited condition
888	Running indication under compressor ratio limited condition
888	Running indication under low voltage limited condition
888	Running indication under defrost mode

Table 22

\* If the first digit shown on the control board LED is one of the following protection codes (followed by two numerical digits which show the current compressor frequency in Hz), the unit will continue to run but in a limited condition. The only exception is when the system is in defrost mode, which only displays "dF" (without any numerical digits following).

### 18.11 Parameter Check Point Table

To display system parameters, press the “Check” button to index through the series of parameters available. The first time you press the “Check” button, it will display the sequence, and after 1 second it will display the value of the parameter. If you press the “Check” button again, it will display the next sequence. Refer to Figure 74 for check button location on the control board.

- Normal Status, last two digits will display under the following conditions
  - i. Unit not operating (Standby Mode); “outdoor ambient temperature”.
  - ii. Unit operating; displays “compressor operating frequency”.
- After 20 seconds on same parameter, the display will revert back to normal status.
- If a system protection is active, first digit will display “status code”.

No.	Point check content	Example	Remark
0	Outdoor unit capacity: H5=Heat pump 5 ton	H5	H5=Heat Pump 5 ton
1	Outdoor unit mode: 0-standby, 2-cooling, 3-heating	2	0 standby, 2 cooling, 3 heating
2	Outdoor unit set compressor speed	56	Hz
3	System last fault code	E4	system
4	Liquid valve subcooling (°F)	10	°F
5	Gas valve superheat (°F)	10	°F
6	T3: outdoor coil temp.(°F)	108	°F
7	T3L: outdoor coil outlet temp.(°F)	102	°F
8	T4: outdoor ambient temp.(°F)	95	°F
9	T5: compressor discharge temp.(°F)	140	°F
10	Th: compressor suction temp.(°F)	55	°F
11	T7: outdoor outlet temp.(°F)	55	°F
12	T6A: injection inlet of the plate heat exchanger temp.(°F)	55	°F
13	T6B: injection outlet of the plate heat exchanger temp.(°F)	55	°F
14	Compressor IPM temp.(°F)	120	°F
15	Pe: evaporating pressure(psig)	130	psig
16	Pc: condensing pressure(psig)	320	psig
17	Tes: target evaporating temp.(°F) (only for cooling mode)	43	°F
18	Te: evaporating temp.(°F)	43	°F
19	Tcs: target condensing temp.(°F)(only for heating mode)	106	°F
20	Tc: condensing temp.(°F)	106	°F
21	Target value of the compressor discharge superheat(°F) (only for heating mode)	36	°F
22	Compressor discharge superheat (°F)	36	°F
23	Compressor Suction superheat (°F)	10	°F
24	Openings of EEVA(P)	200	0-480P
25	Openings of EEVC(P)	200	0-480P
26	Fan speed stage	8	(0-10)
27	Outdoor unit fan current(A)	1	A
28	Compressor current(A)	10	A
29	Outdoor unit input current(A)	10	A
30	Outdoor unit input voltage(V)	230	V
31	Outdoor unit DC bus voltage(V)	380	V
32	Outdoor unit power(*0.1kW)	200	Outdoor unit * 0.1 kW
33	Continuous running time of the compressor(min)	35	minutes/0-999/Maintain at maximum
34	Outdoor unit main control software version	11	11
35	Indoor unit motor power(W)	300	W
36	Indoor unit Heat Kit Staging	1	0~3
37	T1: Indoor unit ambient temp.(°F)	55	°F
38	T2: indoor unit coil temp.(°F)	55	°F
39	Indoor unit software version	11	
40	Demand Response Setting	1	1~3
41	reserved	--	--
42	Remark“--”	--	--

Table 23 Parameter check points

### 18.12 Control Board Overviews

#### Main Control Board for 48/60 ODU Model

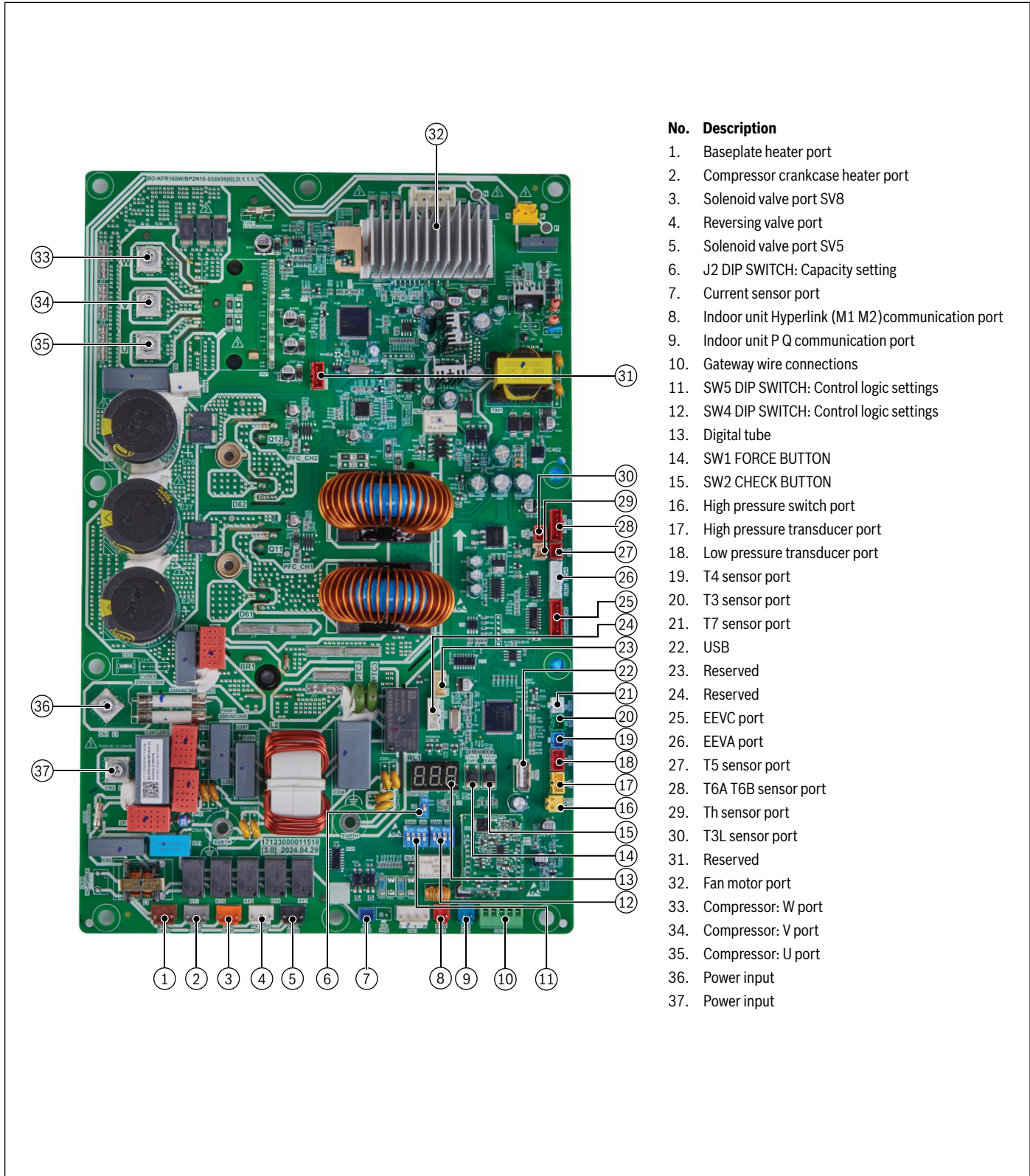

- | No. | Description                                      |
|-----|--|
| 1.  | Baseplate heater port                            |
| 2.  | Compressor crankcase heater port                 |
| 3.  | Solenoid valve port SV8                          |
| 4.  | Reversing valve port                             |
| 5.  | Solenoid valve port SV5                          |
| 6.  | J2 DIP SWITCH: Capacity setting                  |
| 7.  | Current sensor port                              |
| 8.  | Indoor unit Hyperlink (M1 M2) communication port |
| 9.  | Indoor unit P Q communication port               |
| 10. | Gateway wire connections                         |
| 11. | SW5 DIP SWITCH: Control logic settings           |
| 12. | SW4 DIP SWITCH: Control logic settings           |
| 13. | Digital tube                                     |
| 14. | SW1 FORCE BUTTON                                 |
| 15. | SW2 CHECK BUTTON                                 |
| 16. | High pressure switch port                        |
| 17. | High pressure transducer port                    |
| 18. | Low pressure transducer port                     |
| 19. | T4 sensor port                                   |
| 20. | T3 sensor port                                   |
| 21. | T7 sensor port                                   |
| 22. | USB  |
| 23. | Reserved   |
| 24. | Reserved   |
| 25. | EEVC port  |
| 26. | EEVA port  |
| 27. | T5 sensor port                                   |
| 28. | T6A T6B sensor port                              |
| 29. | Th sensor port                                   |
| 30. | T3L sensor port                                  |
| 31. | Reserved   |
| 32. | Fan motor port                                   |
| 33. | Compressor: W port                               |
| 34. | Compressor: V port                               |
| 35. | Compressor: U port                               |
| 36. | Power input                                      |
| 37. | Power input                                      |

Figure 72

**18.13 Error Code Troubleshooting**

**WARNING**

**Hazardous voltage!**

When measuring resistance, make sure the unit is powered off and wait 3 min before taking measurement.

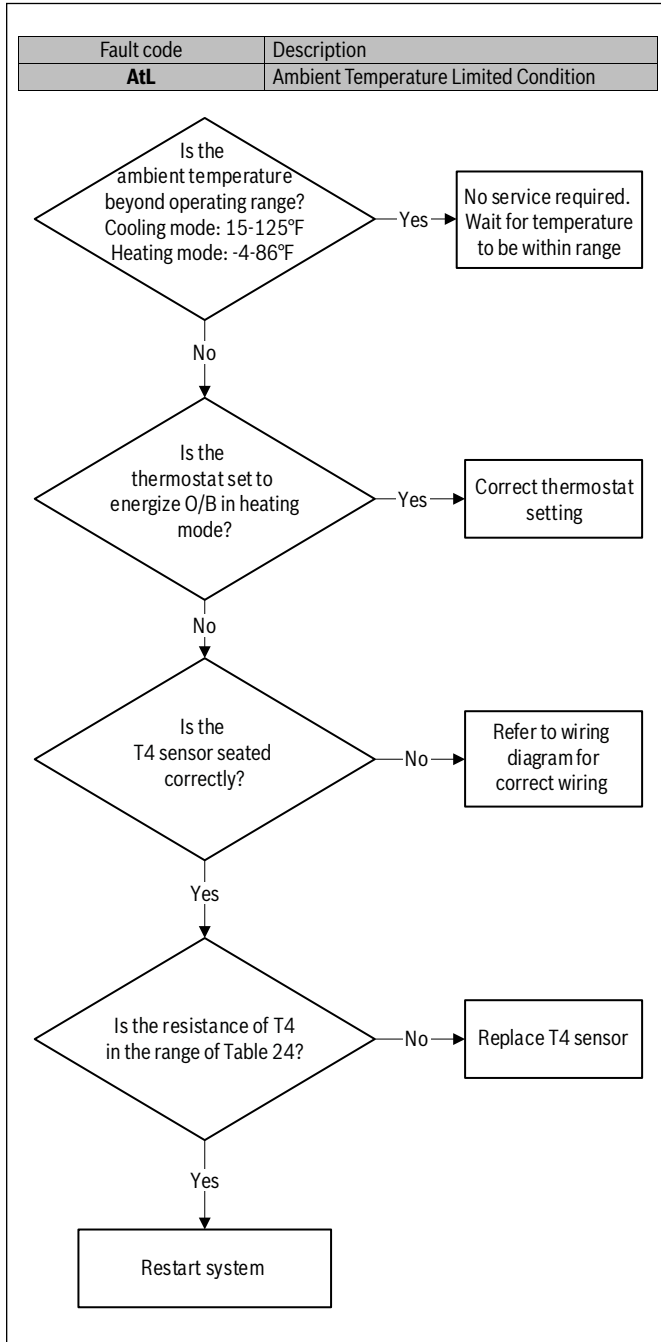

Figure 73

**WARNING**

**Hazardous voltage!**

When measuring resistance, make sure the unit is powered off and wait 3 min before taking measurement.

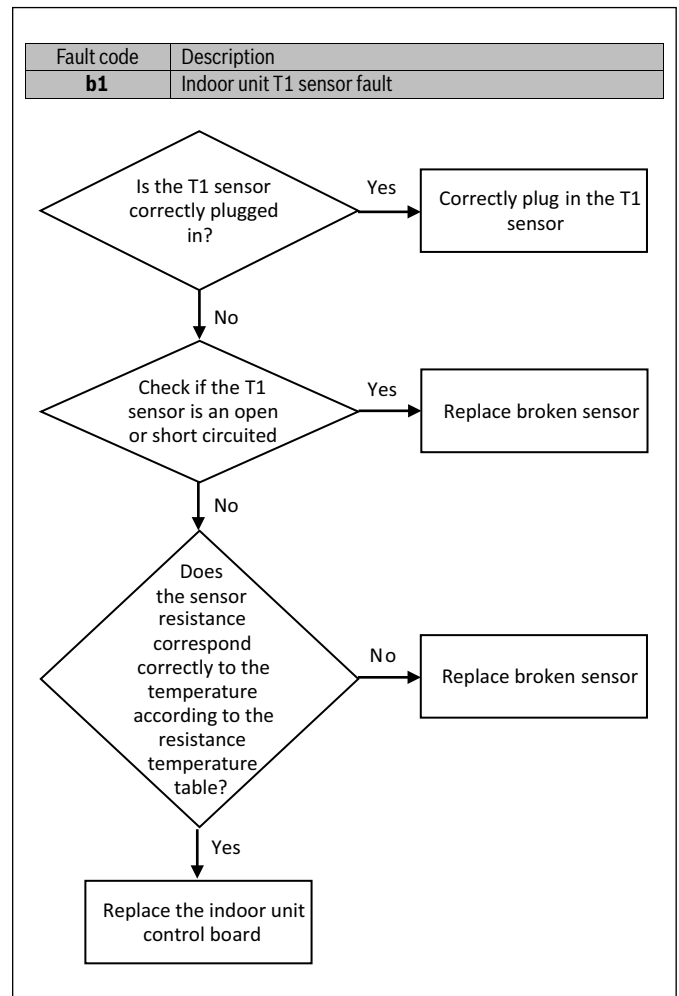

Figure 74

**WARNING**

**Hazardous voltage!**

When measuring resistance, make sure the unit is powered off and wait 3 min before taking measurement.

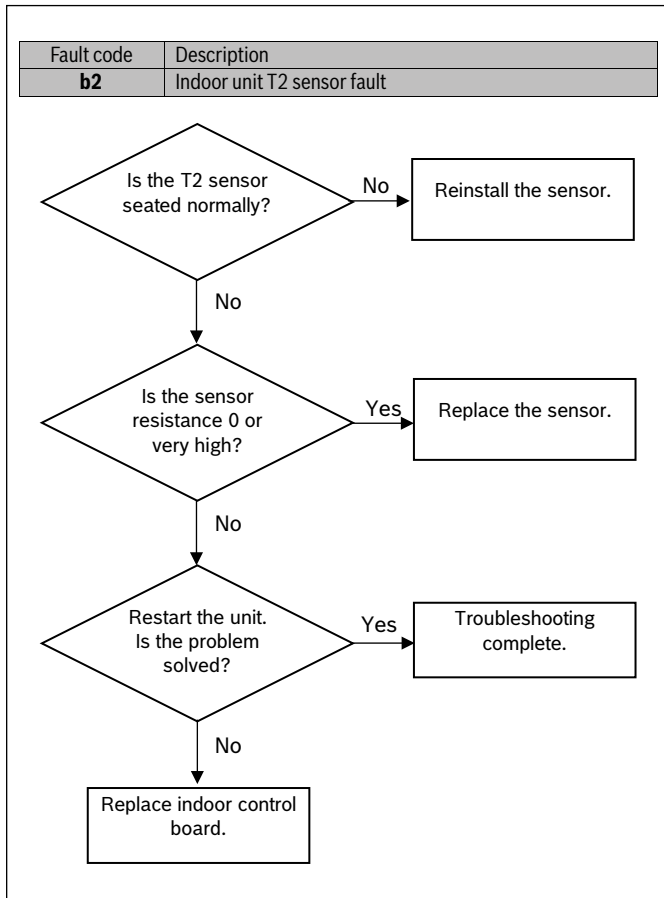

Figure 75

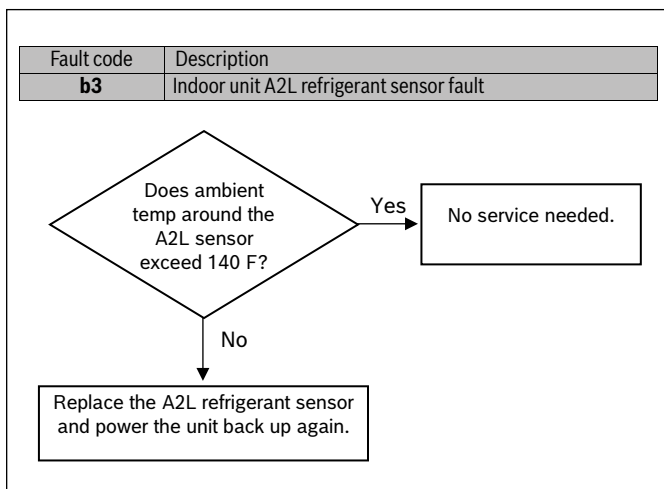

Figure 76

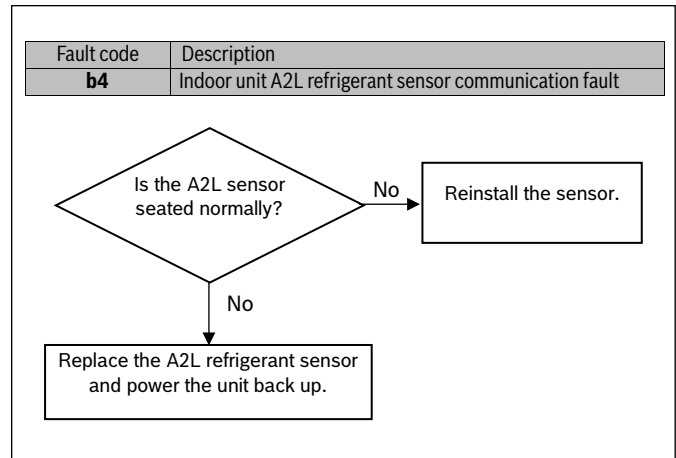

Figure 77

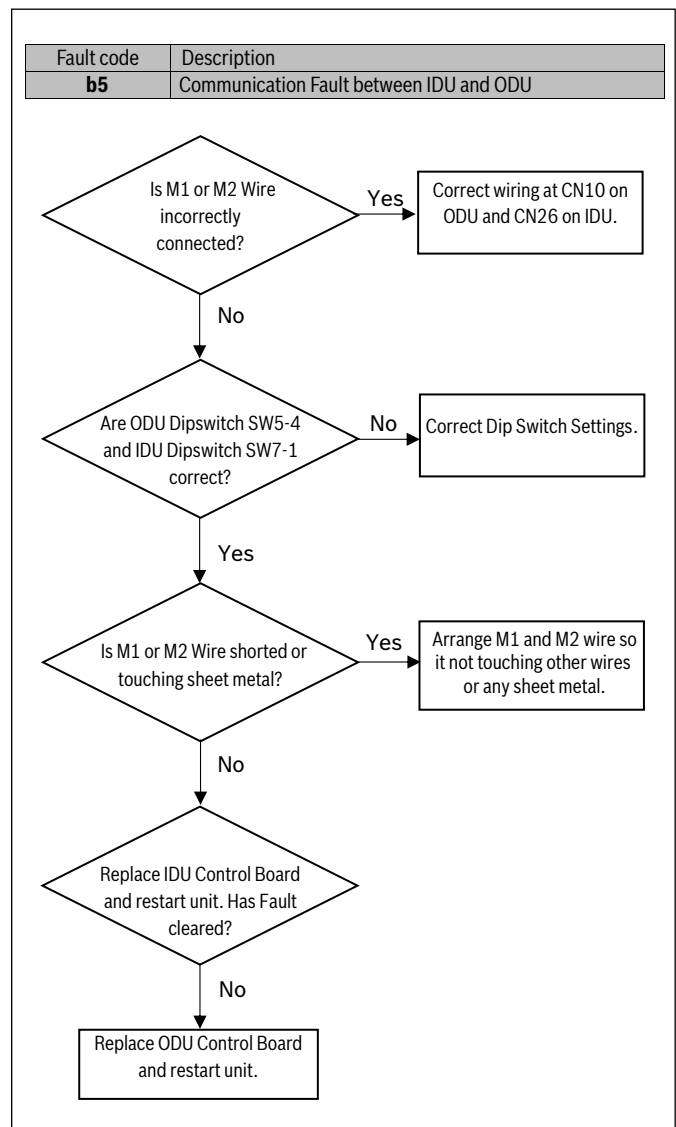

Figure 78

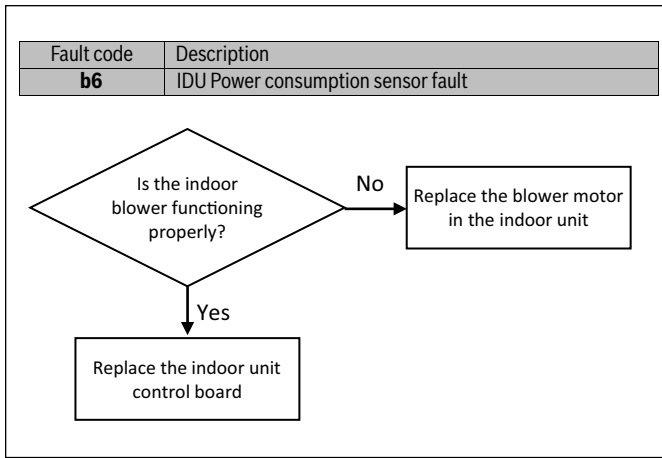

Figure 79

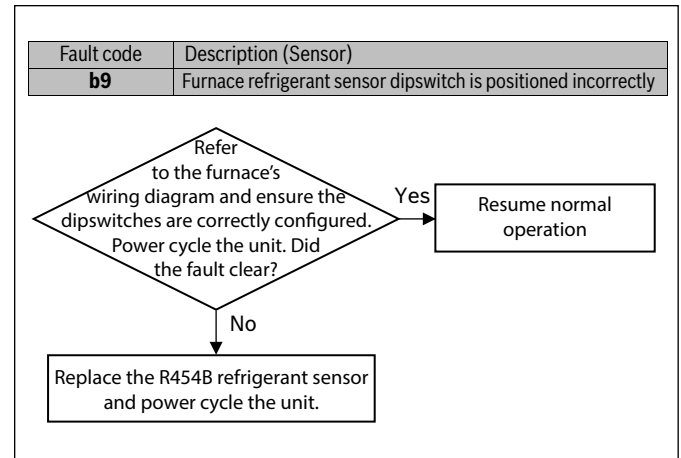

Figure 82



The b9 fault will only be displayed on the outdoor unit when communicating with a BGH96 RevC/BGH97 Furnace or IDS Communication Accessory Kit.

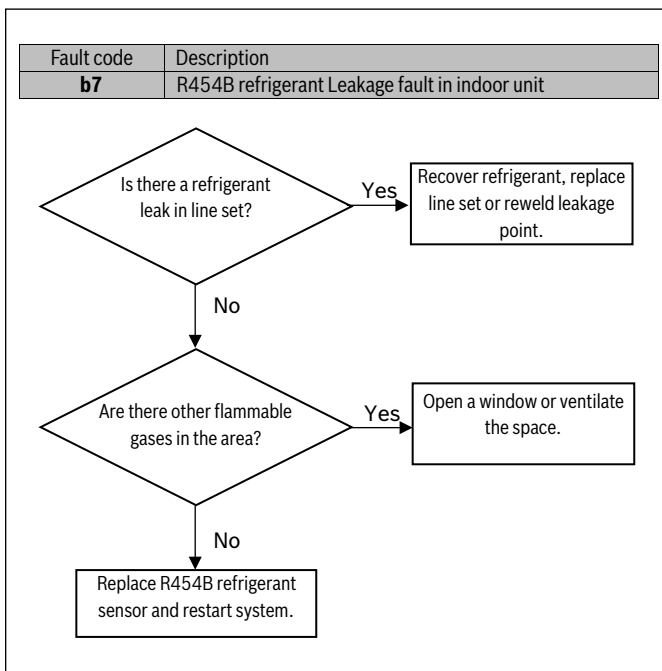

Figure 80

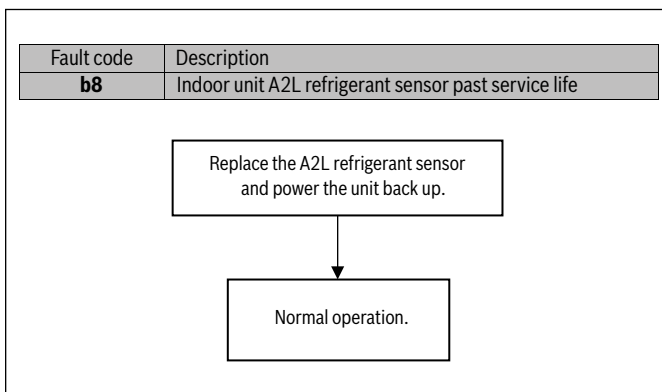

Figure 81

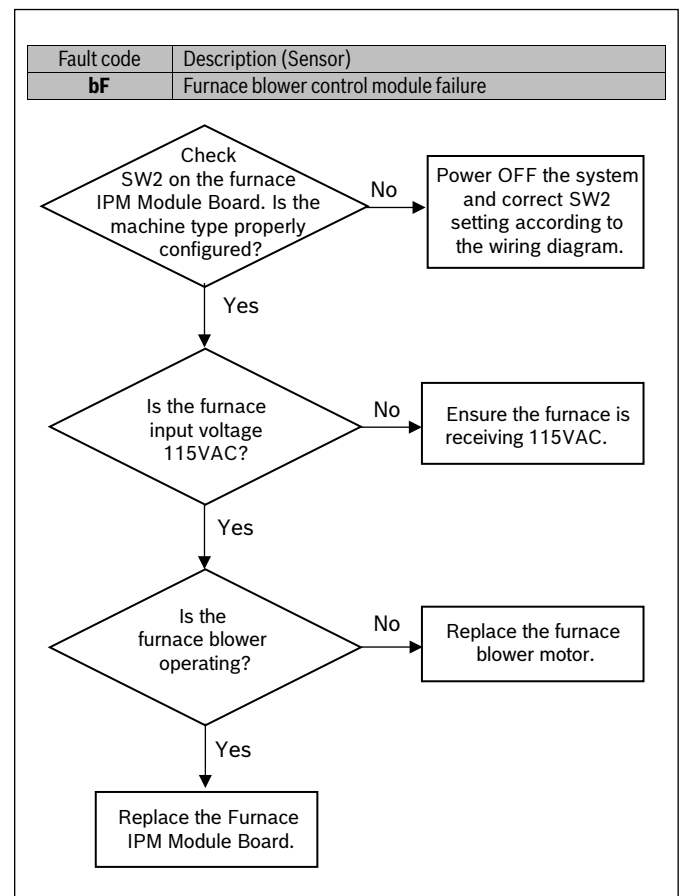

Figure 83

 **WARNING**

**Hazardous voltage!**

When measuring resistance , make sure the unit is powered off and wait 3 min before taking measurement.

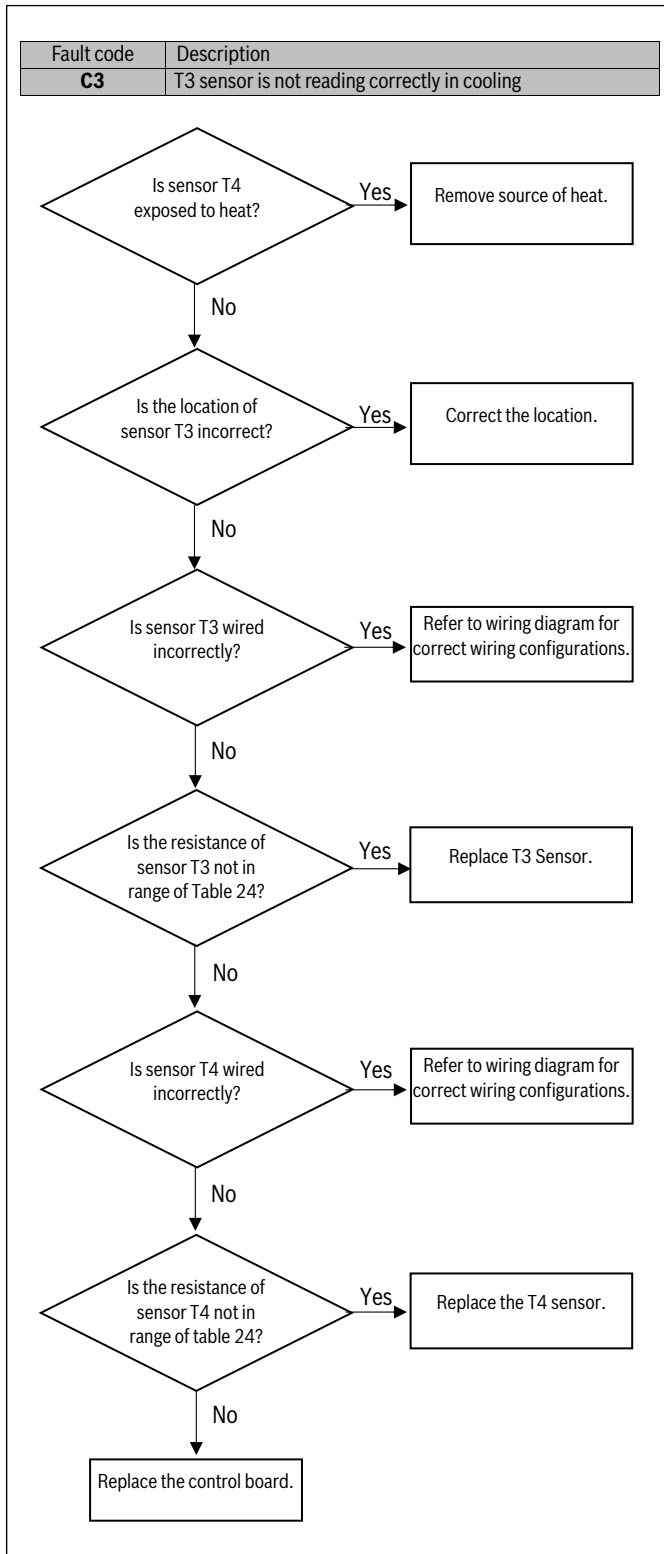

Figure 84

 **WARNING**

**Hazardous voltage!**

When measuring resistance , make sure the unit is powered off and wait 3 min before taking measurement.

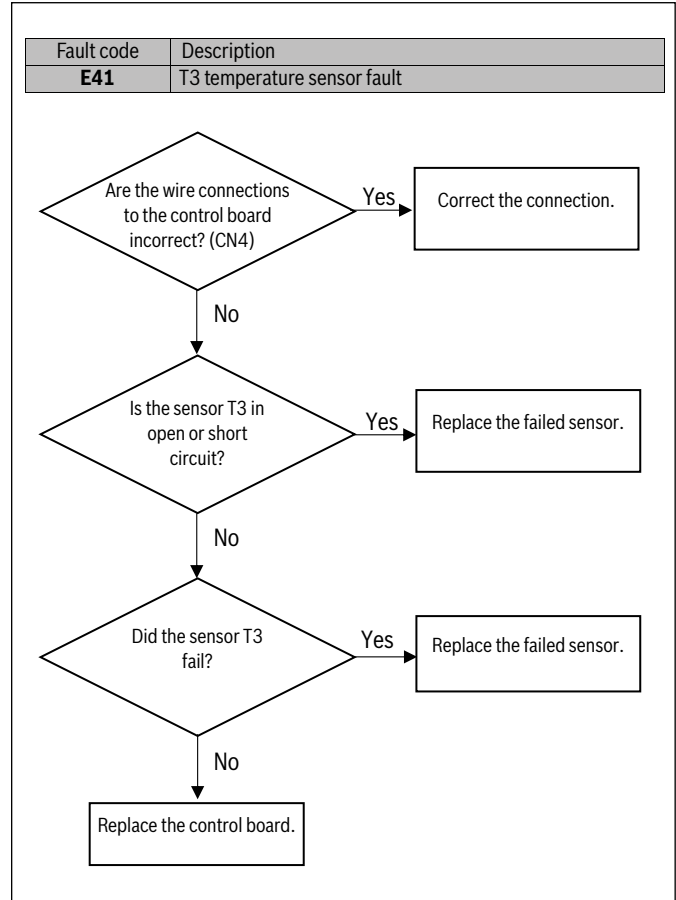

Figure 85

**WARNING**  
**Hazardous voltage!**  
 When measuring resistance , make sure the unit is powered off and wait 3 min before taking measurement.

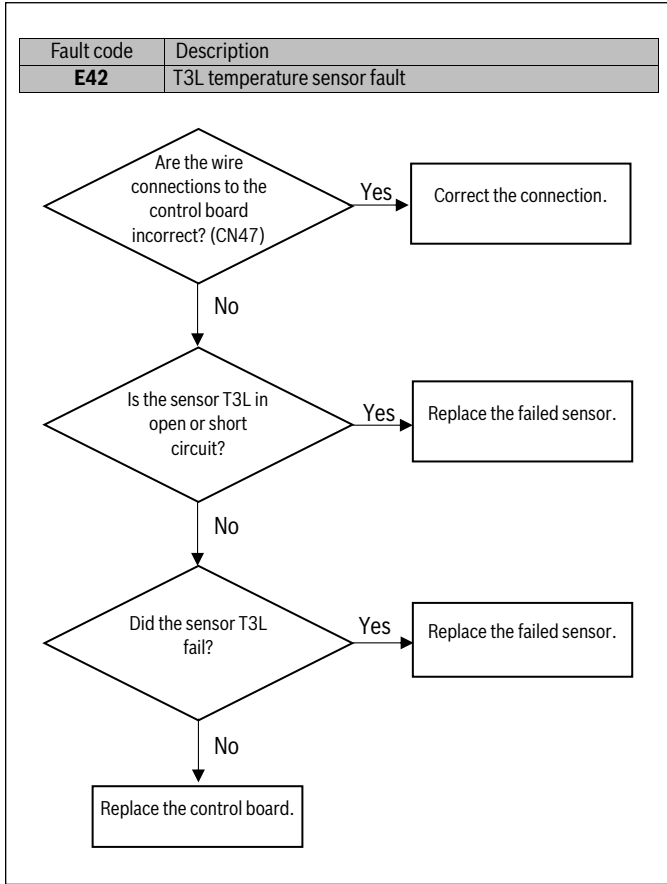

Figure 86

**WARNING**  
**Hazardous voltage!**  
 When measuring resistance , make sure the unit is powered off and wait 3 min before taking measurement.

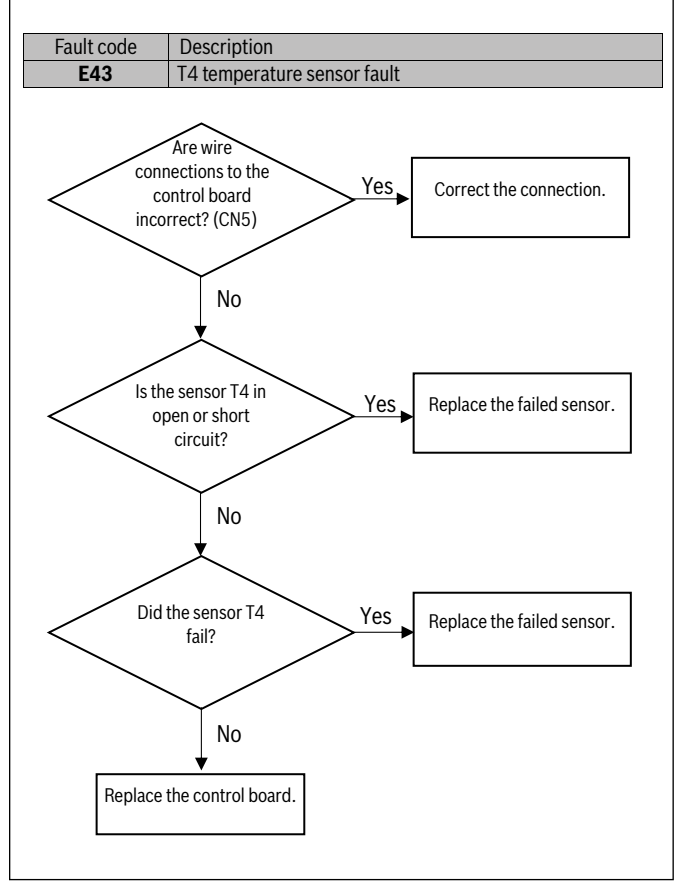

Figure 87

 **WARNING**

**Hazardous voltage!**

When measuring resistance , make sure the unit is powered off and wait 3 min before taking measurement.

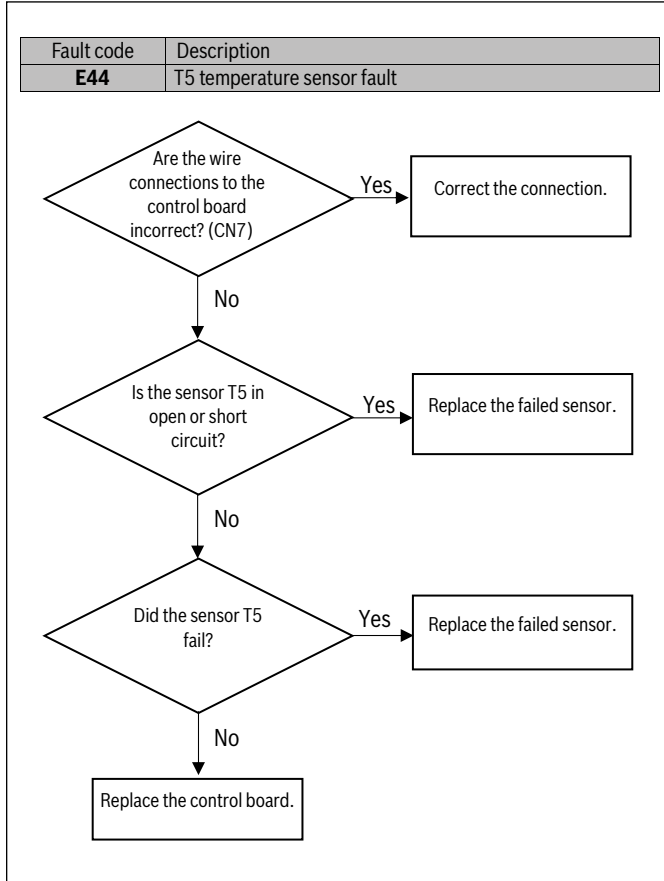

Figure 88

 **WARNING**

**Hazardous voltage!**

When measuring resistance , make sure the unit is powered off and wait 3 min before taking measurement.

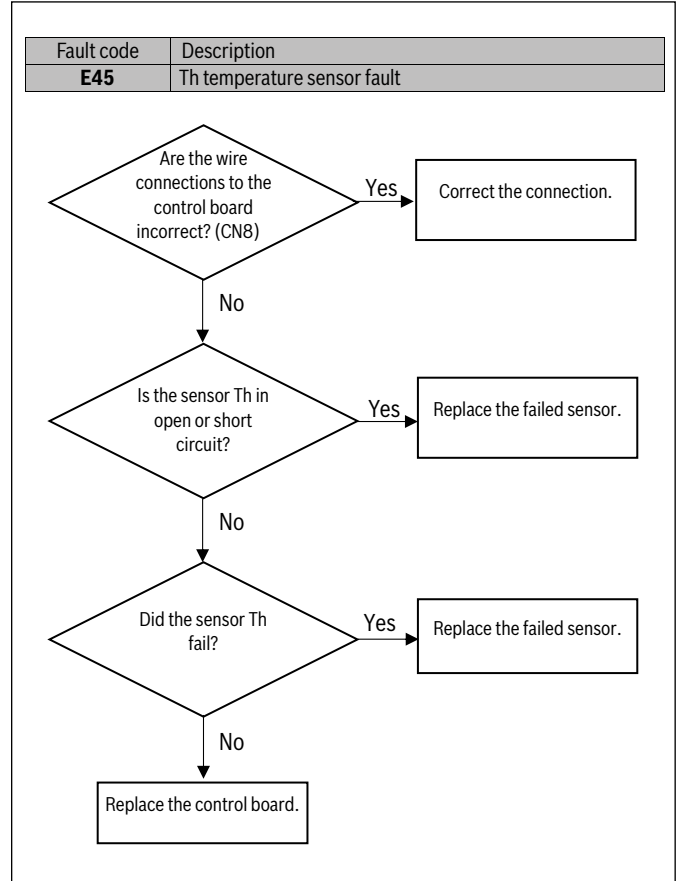

Figure 89

**WARNING**  
**Hazardous voltage!**  
 When measuring resistance , make sure the unit is powered off and wait 3 min before taking measurement.

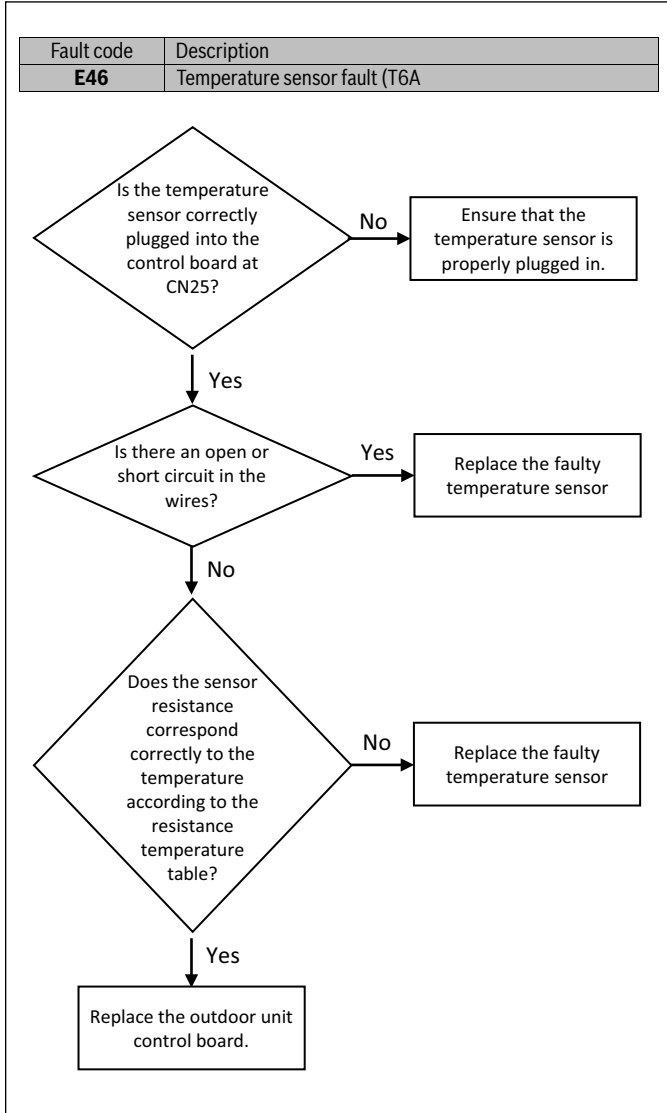

Figure 90

**WARNING**  
**Hazardous voltage!**  
 When measuring resistance , make sure the unit is powered off and wait 3 min before taking measurement.

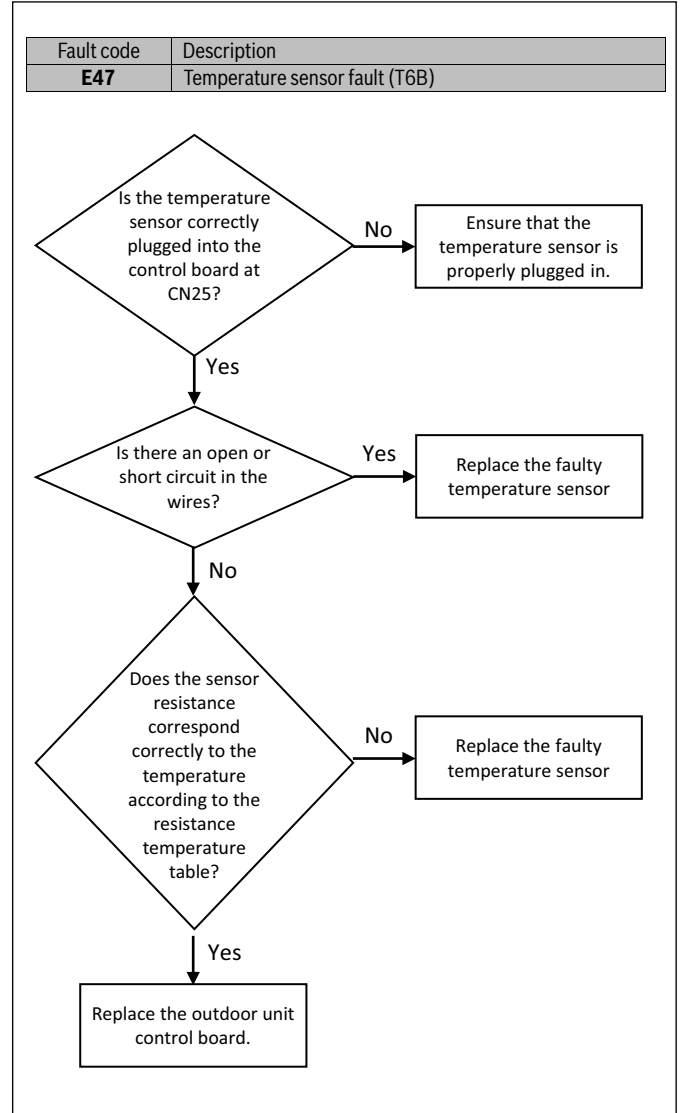

Figure 91

**WARNING**  
**Hazardous voltage!**  
 When measuring resistance , make sure the unit is powered off and wait 3 min before taking measurement.

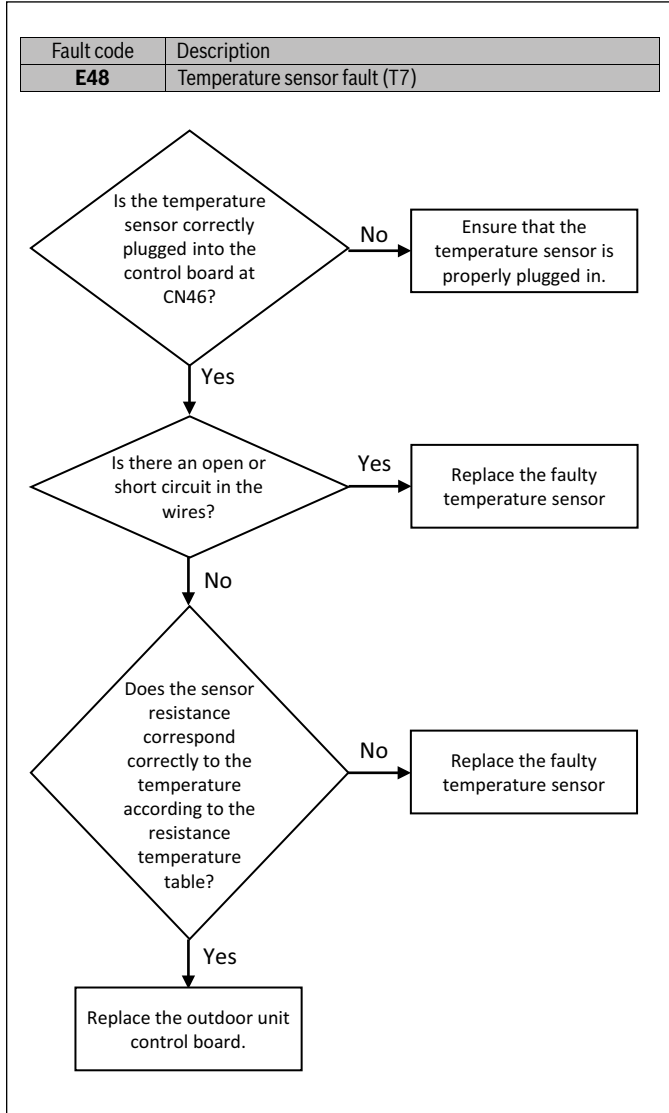

Figure 92

**WARNING**  
**Hazardous voltage!**  
 When measuring resistance , make sure the unit is powered off and wait 3 min before taking measurement.

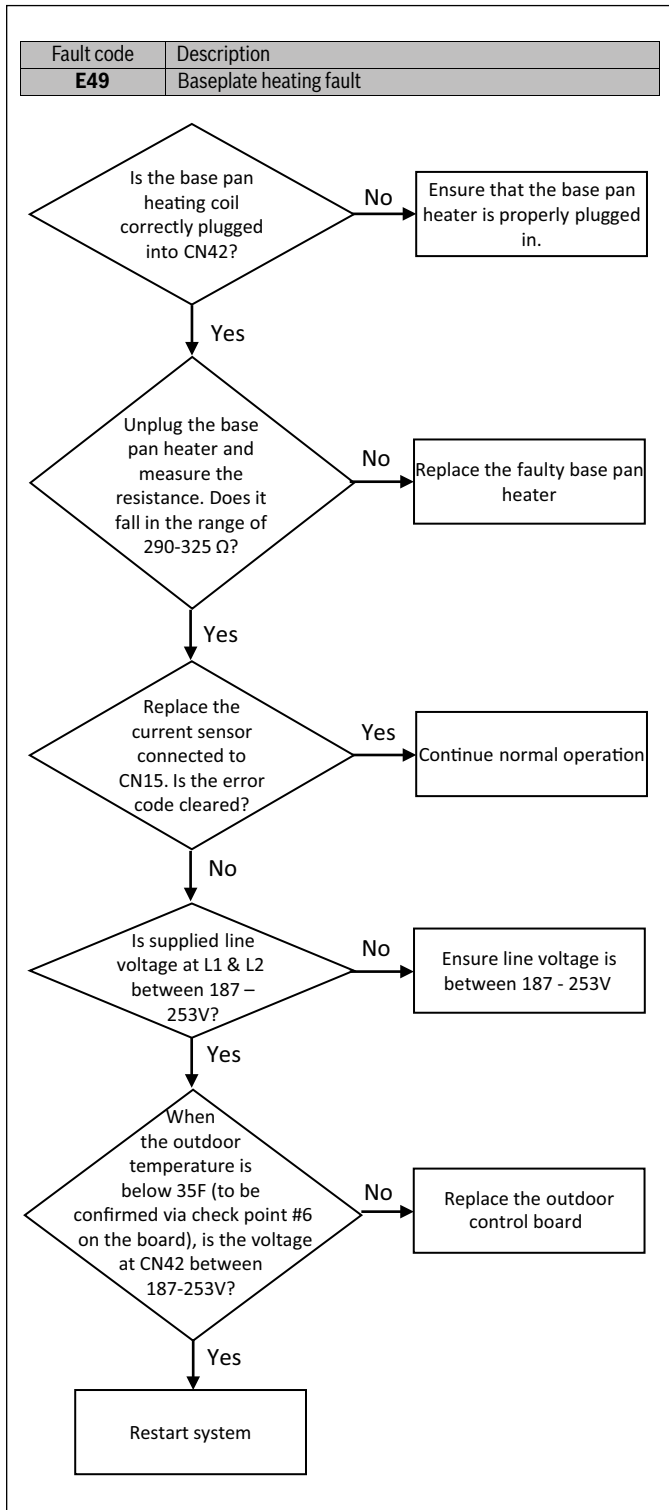

Figure 93

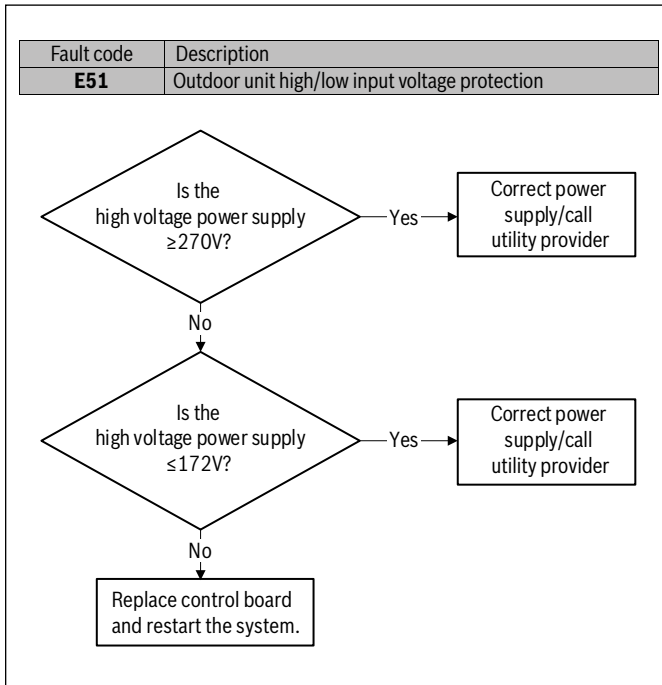

Figure 94

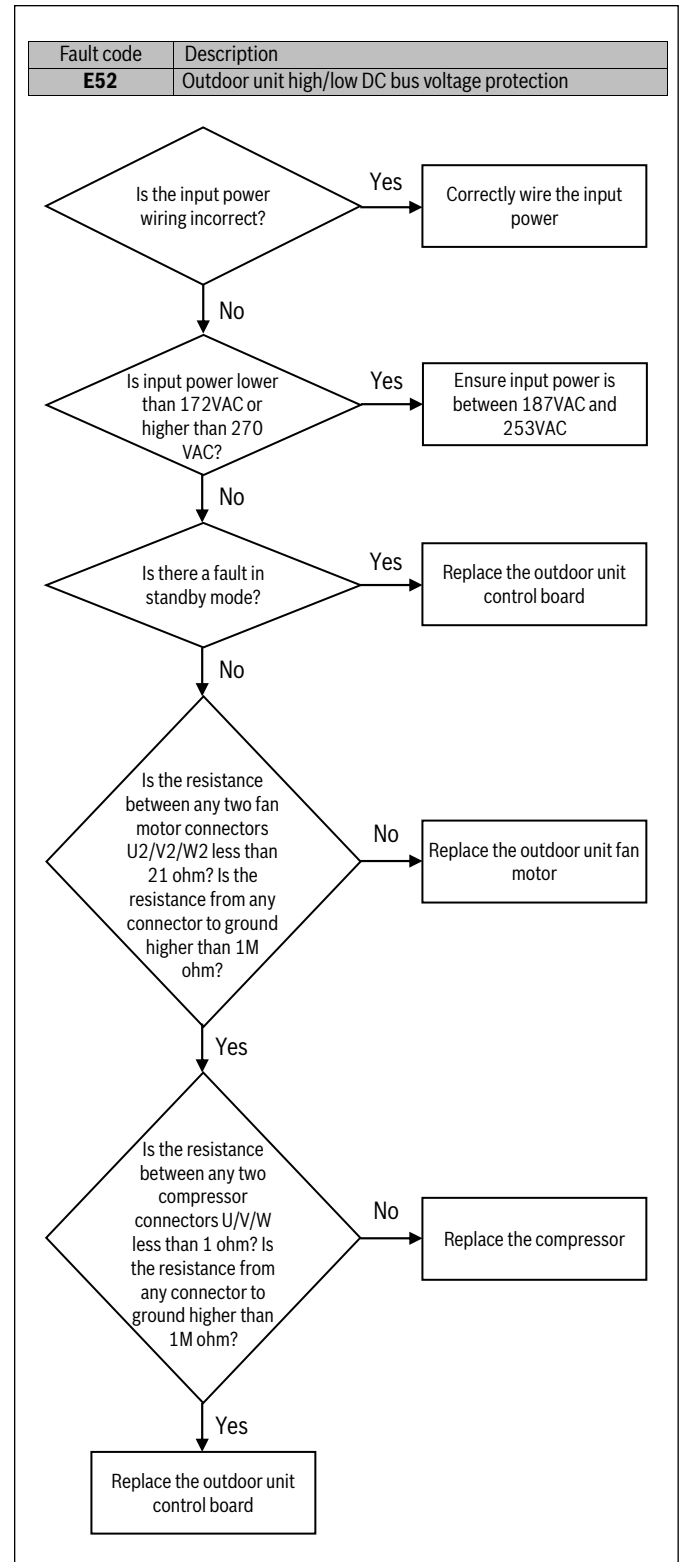

Figure 95

**WARNING**

**Hazardous voltage!**

When measuring resistance, make sure the unit is powered off and wait 3 min before taking measurement.

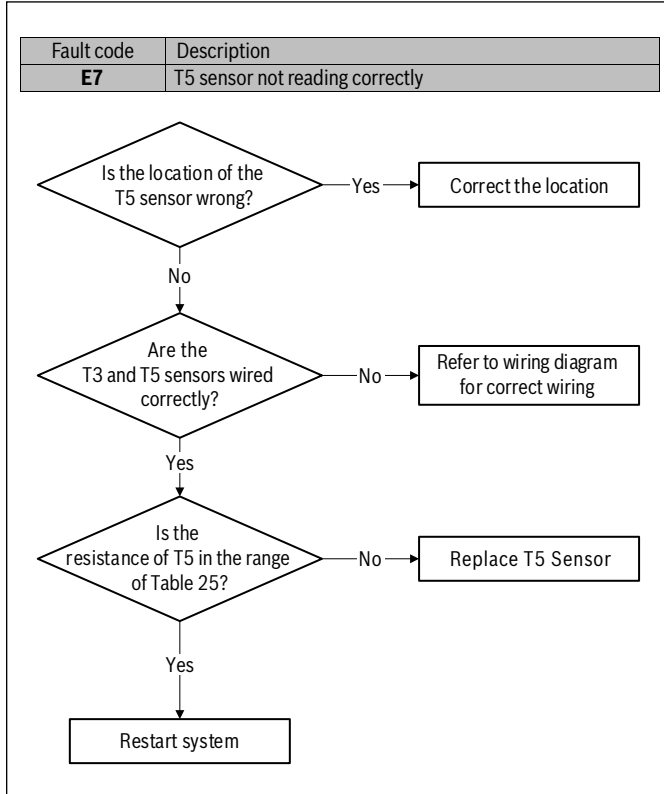

Figure 96

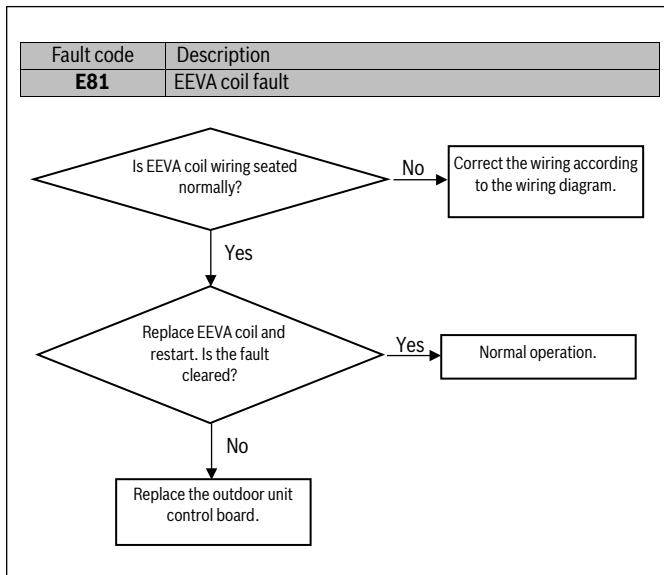

Figure 97

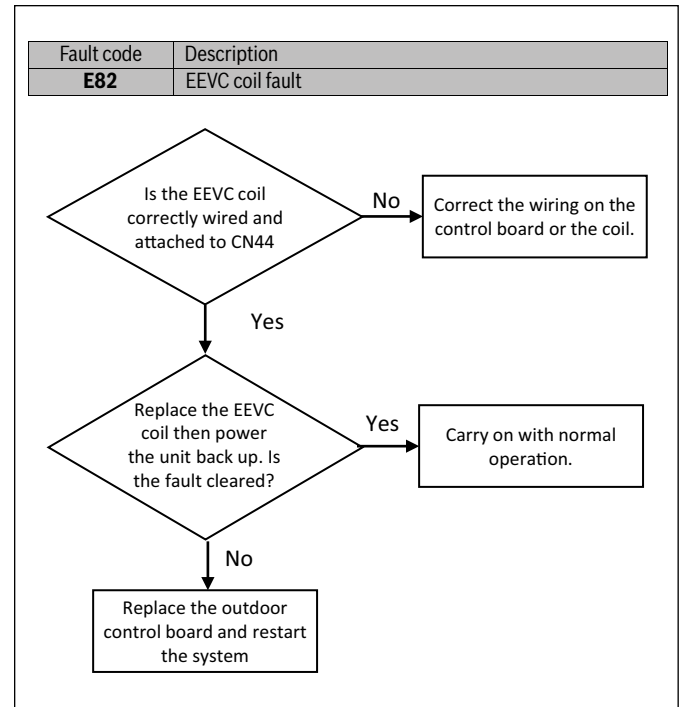

Figure 98

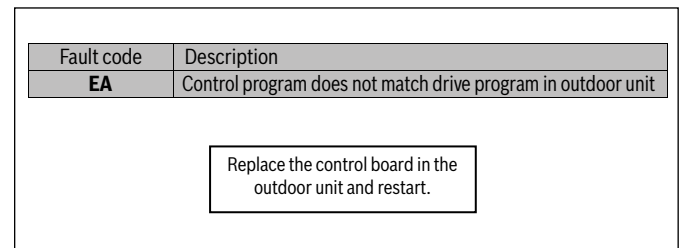

Figure 99

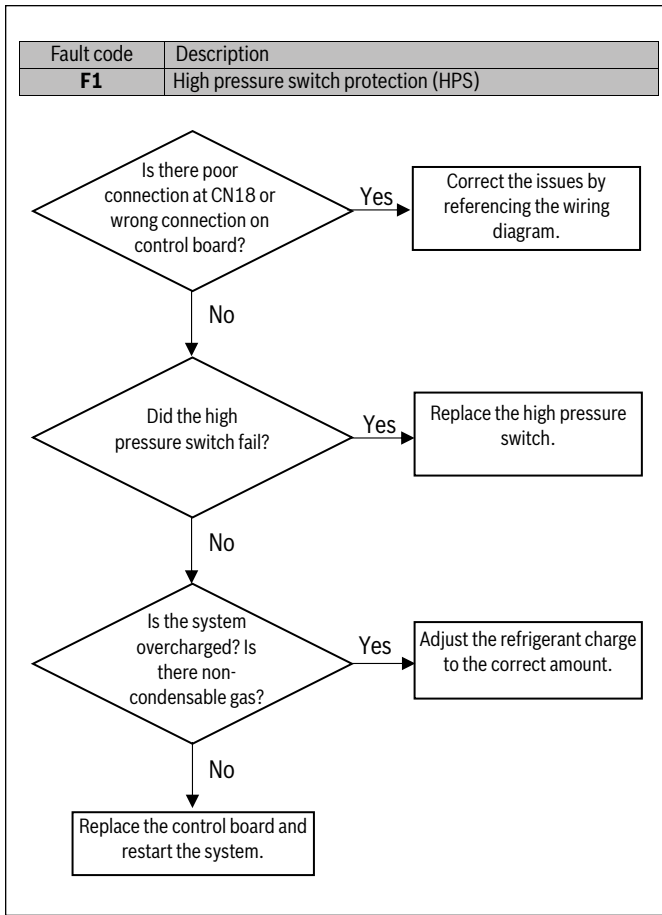

Figure 100

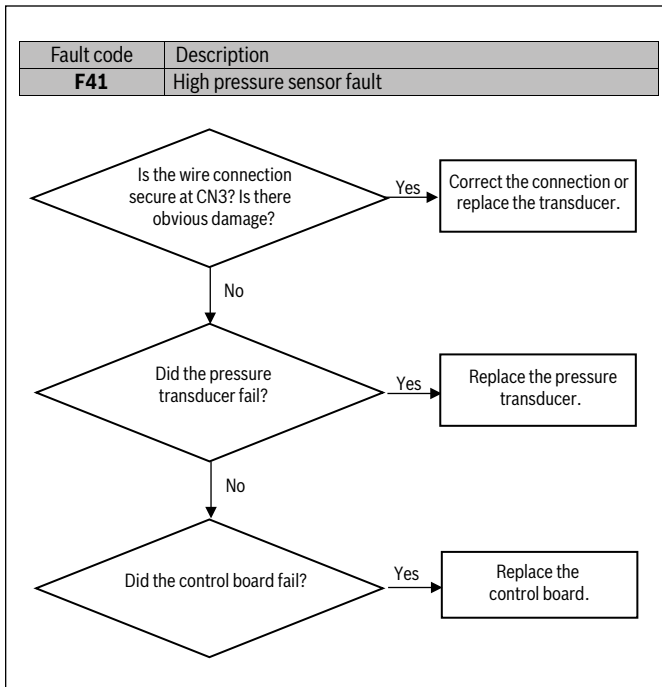

Figure 101

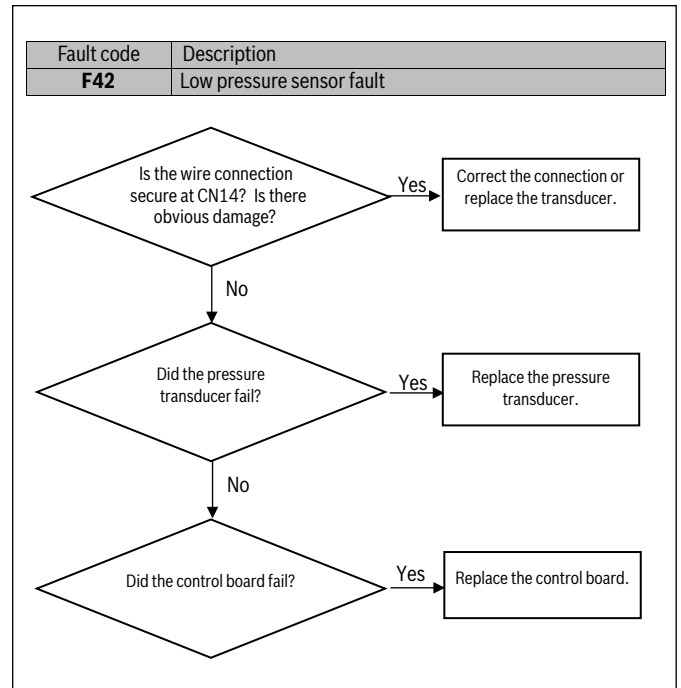

Figure 102

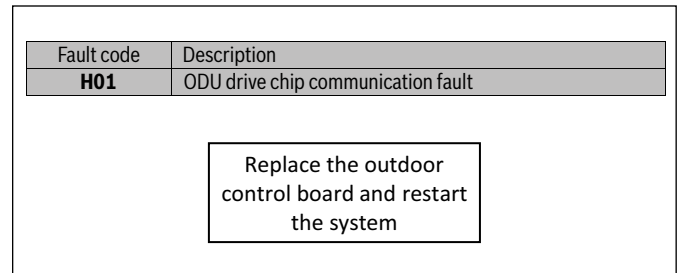

Figure 103

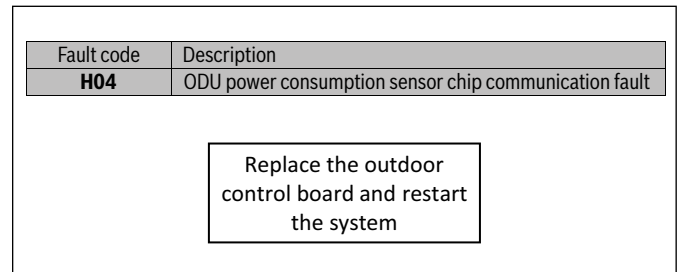

Figure 104

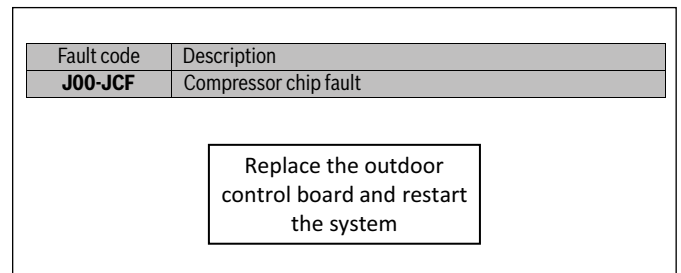

Figure 105

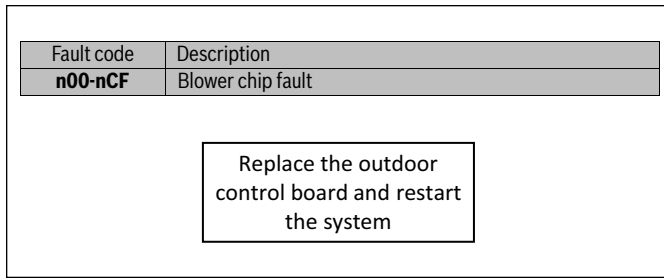

Figure 106

**WARNING**

**Hazardous voltage!**

When measuring resistance , make sure the unit is powered off and wait 3 min before taking measurement.

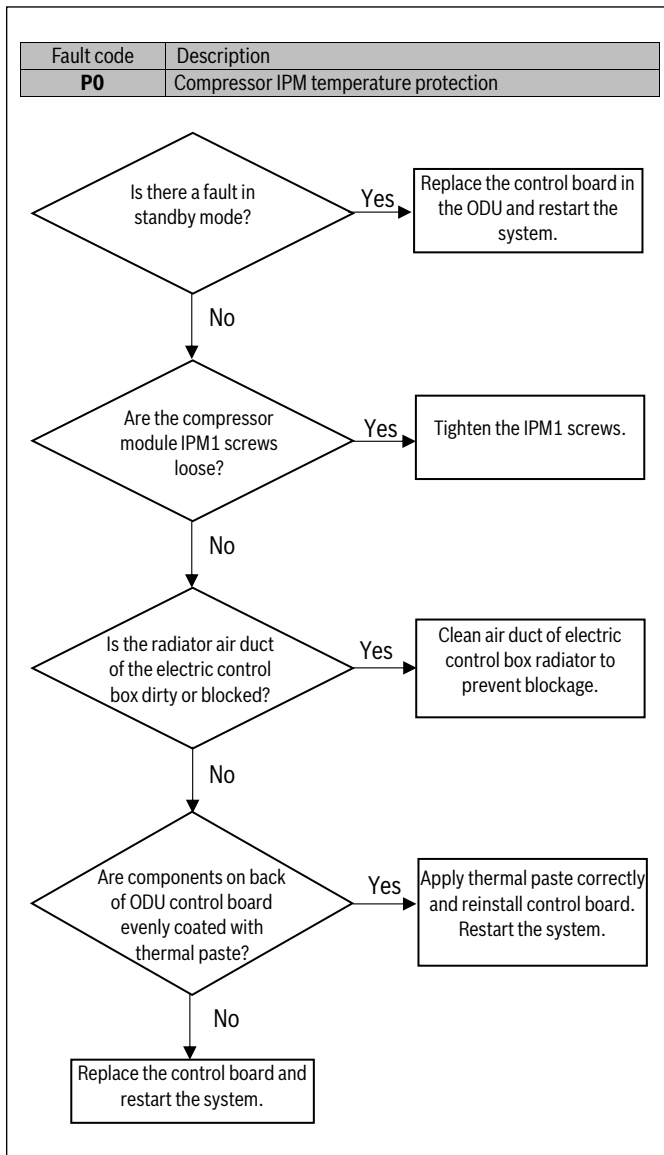

Figure 107

**WARNING**

**Hazardous voltage!**

When measuring resistance , make sure the unit is powered off and wait 3 min before taking measurement.

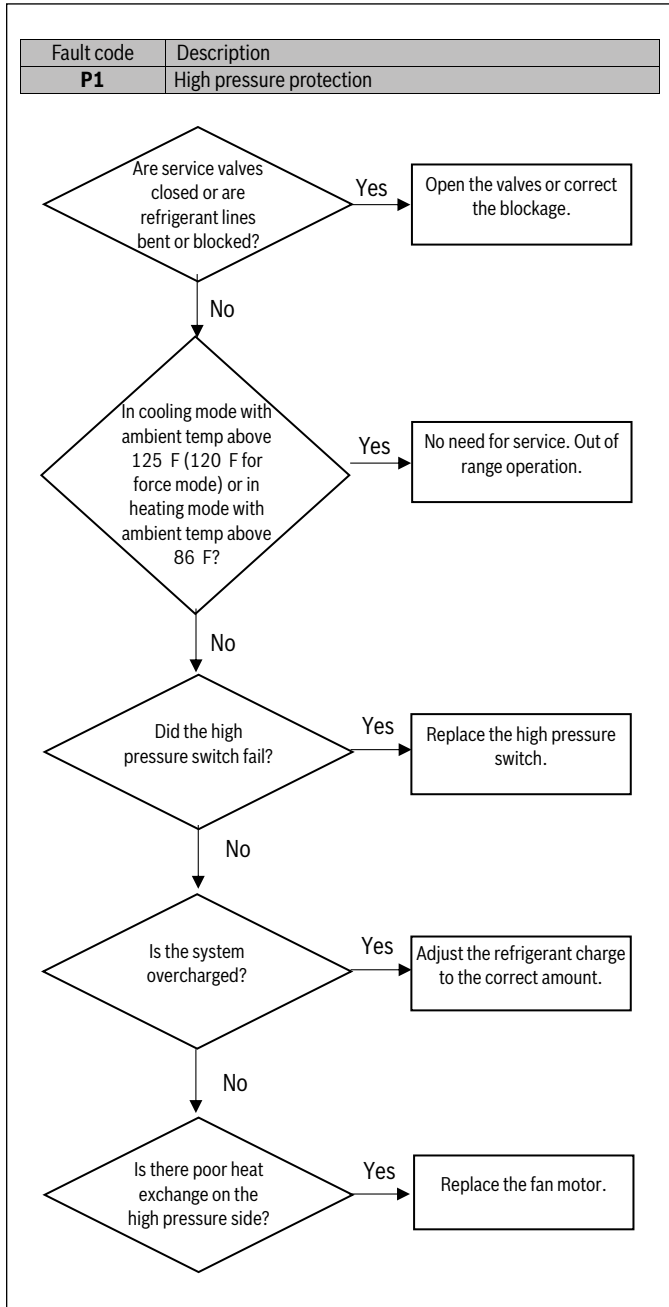

Figure 108

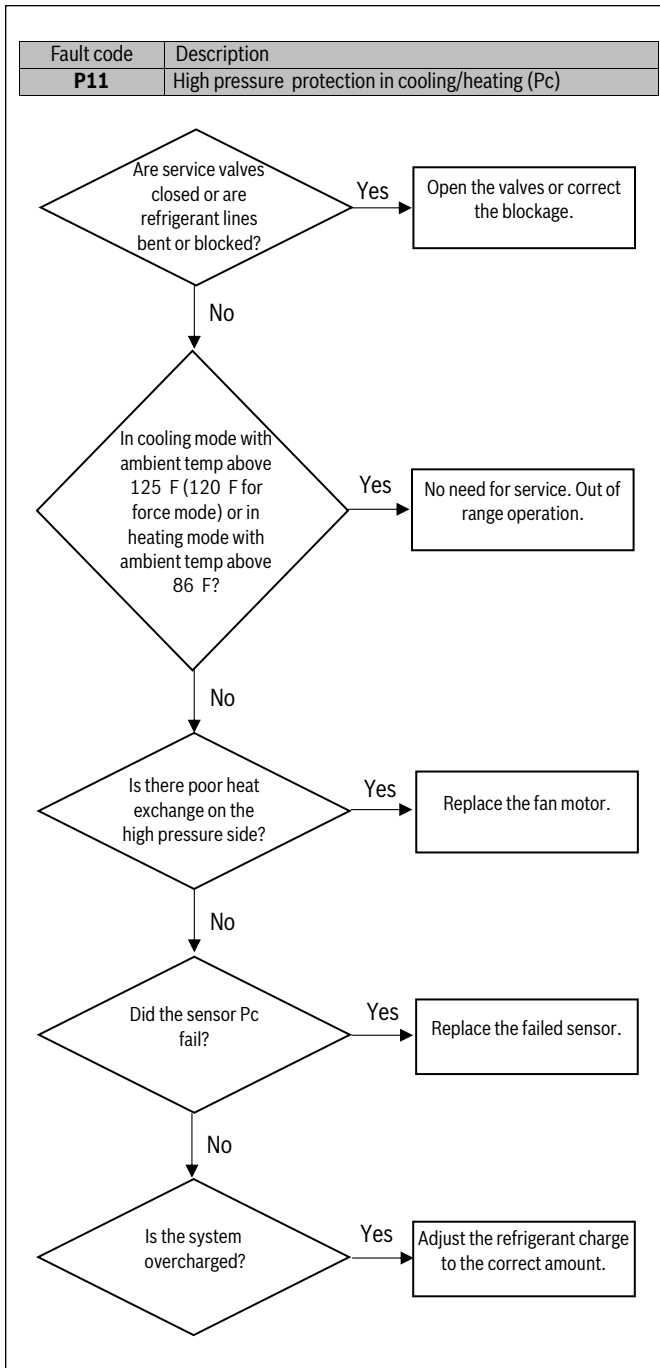

Figure 109

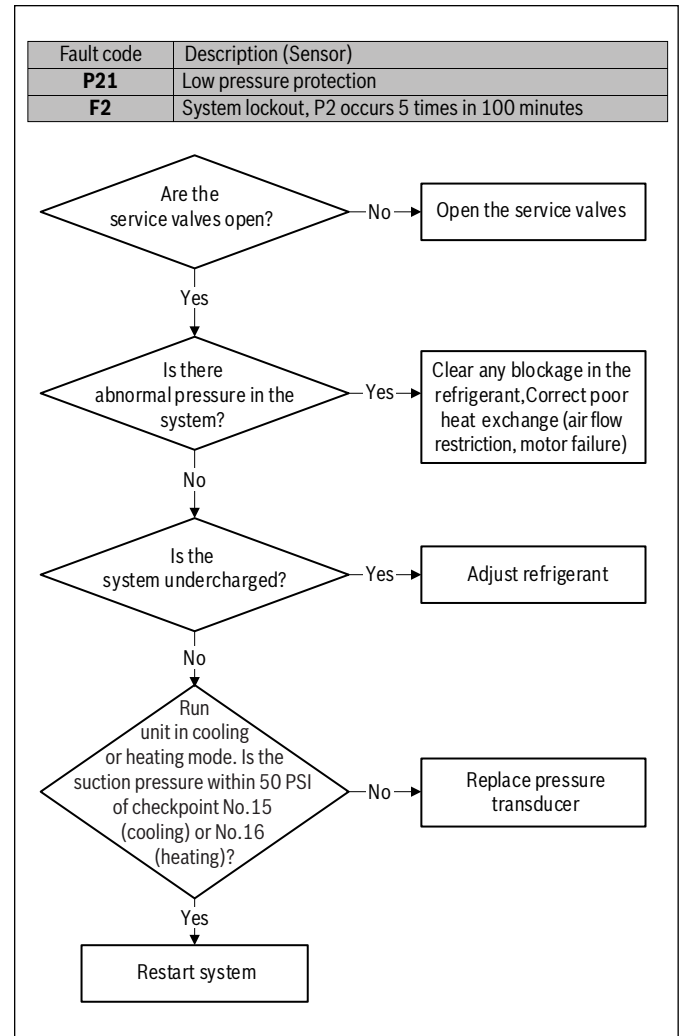

Figure 110

**WARNING**

**Hazardous voltage!**

When measuring resistance, make sure the unit is powered off and wait 3 min before taking measurement.

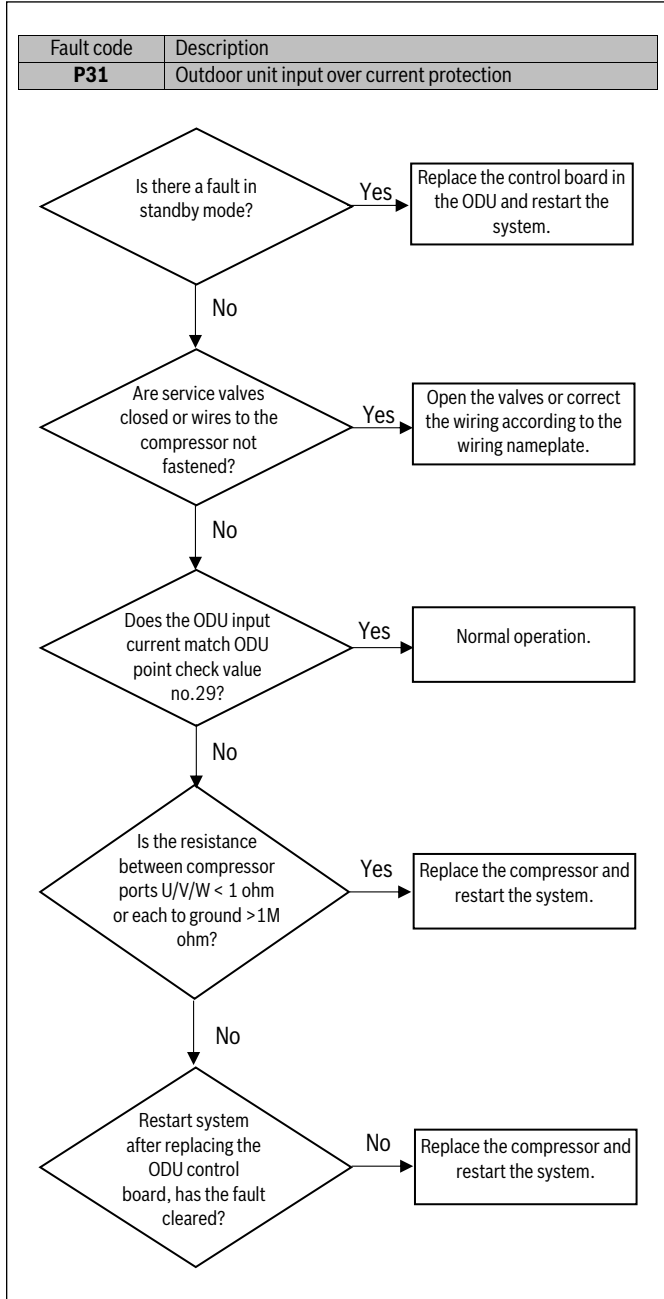

Figure 111

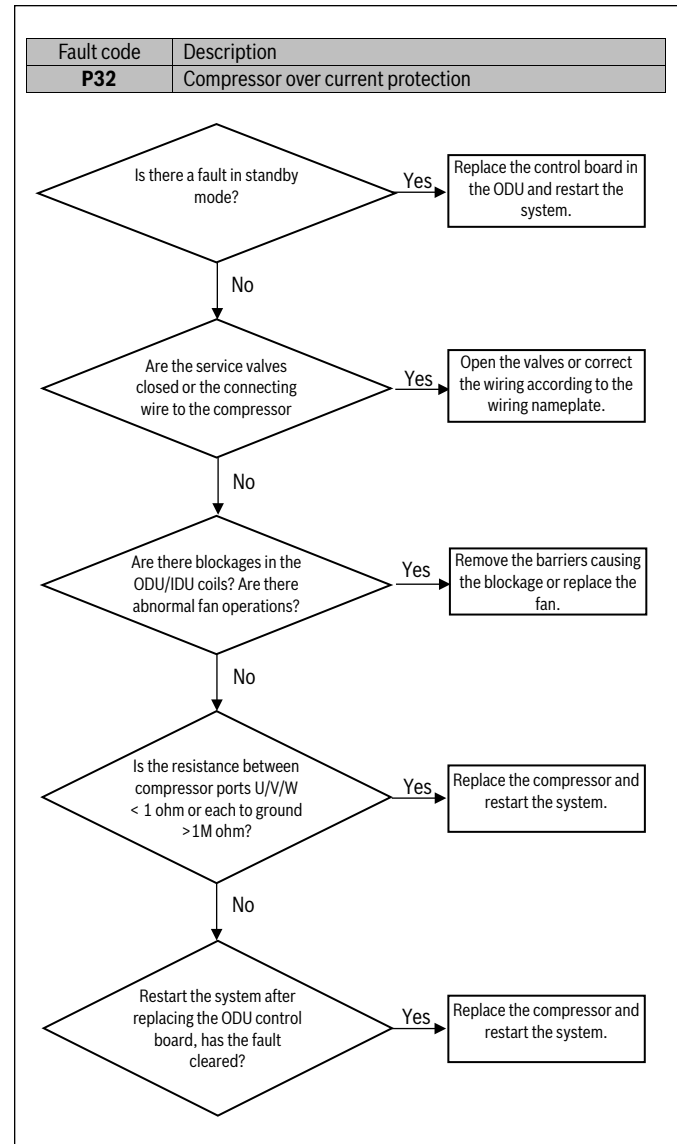

Figure 112

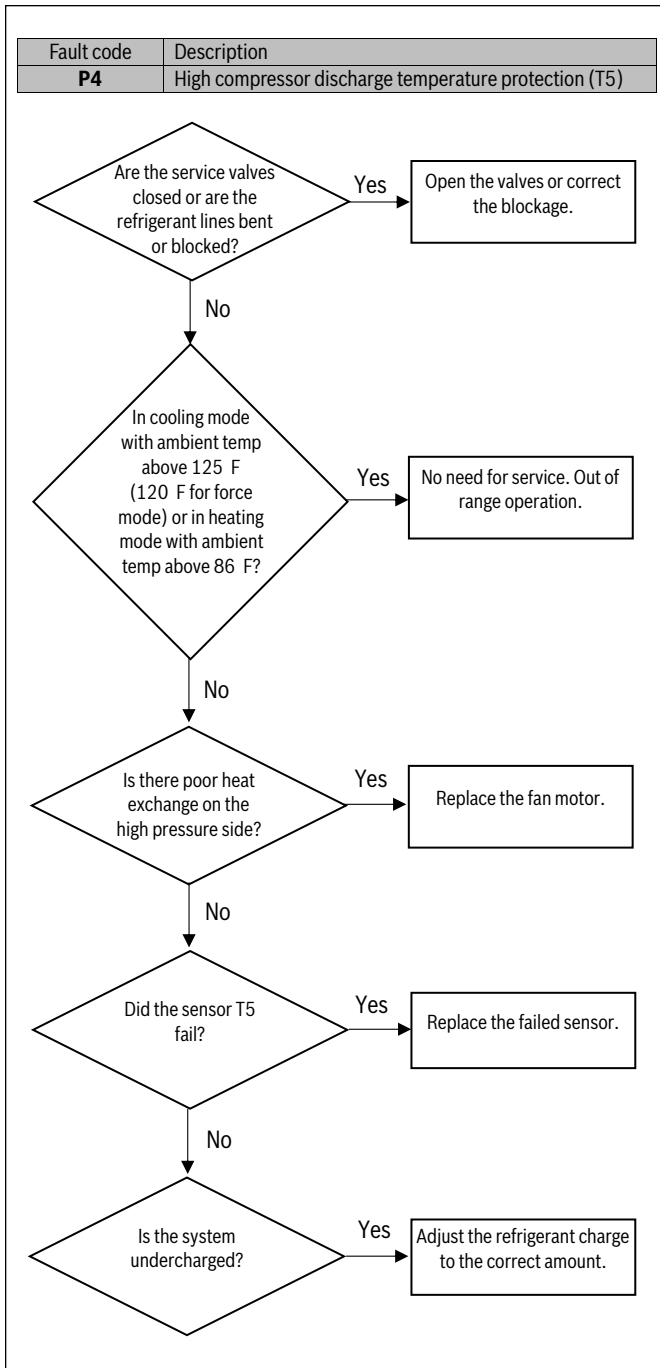

Figure 113

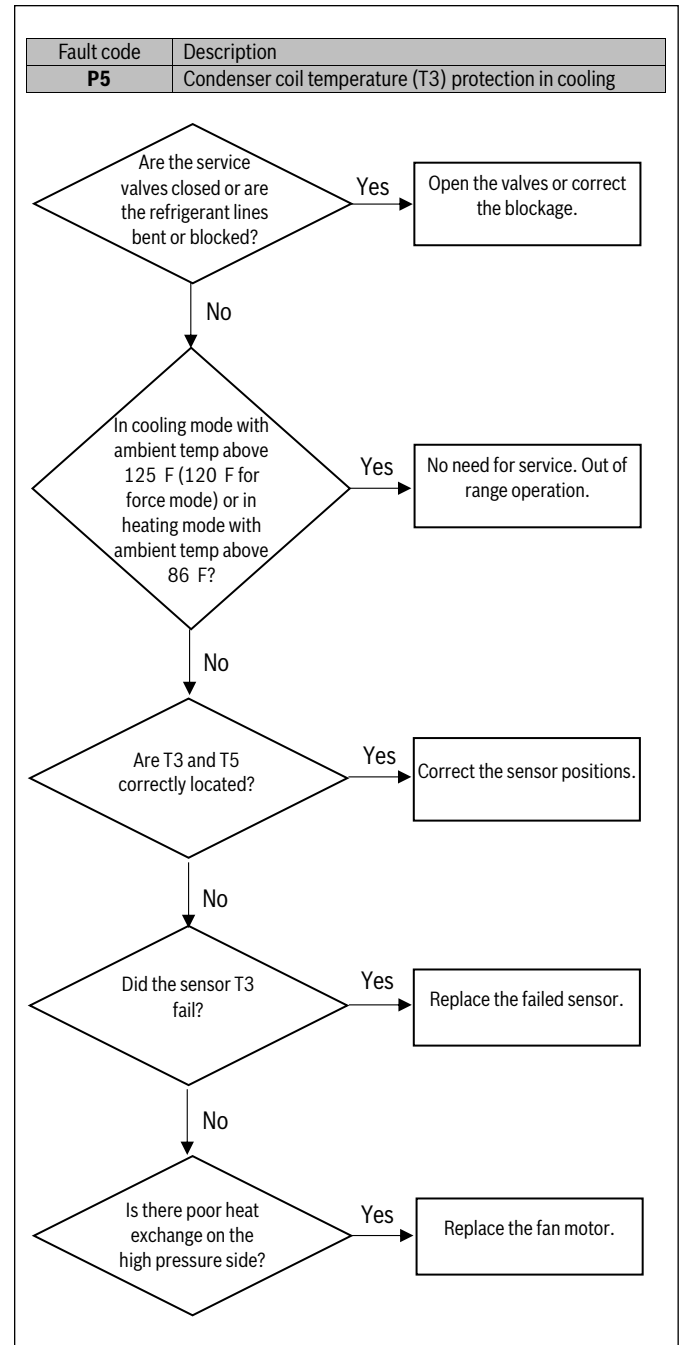

Figure 114

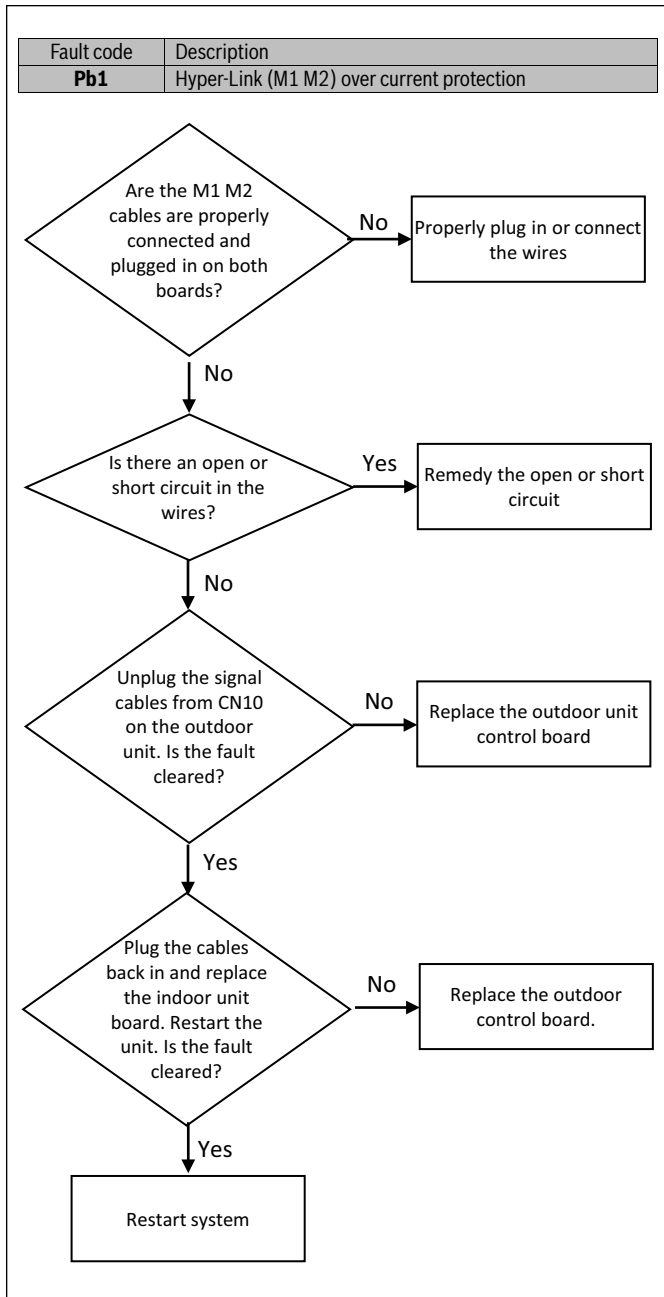

Figure 115

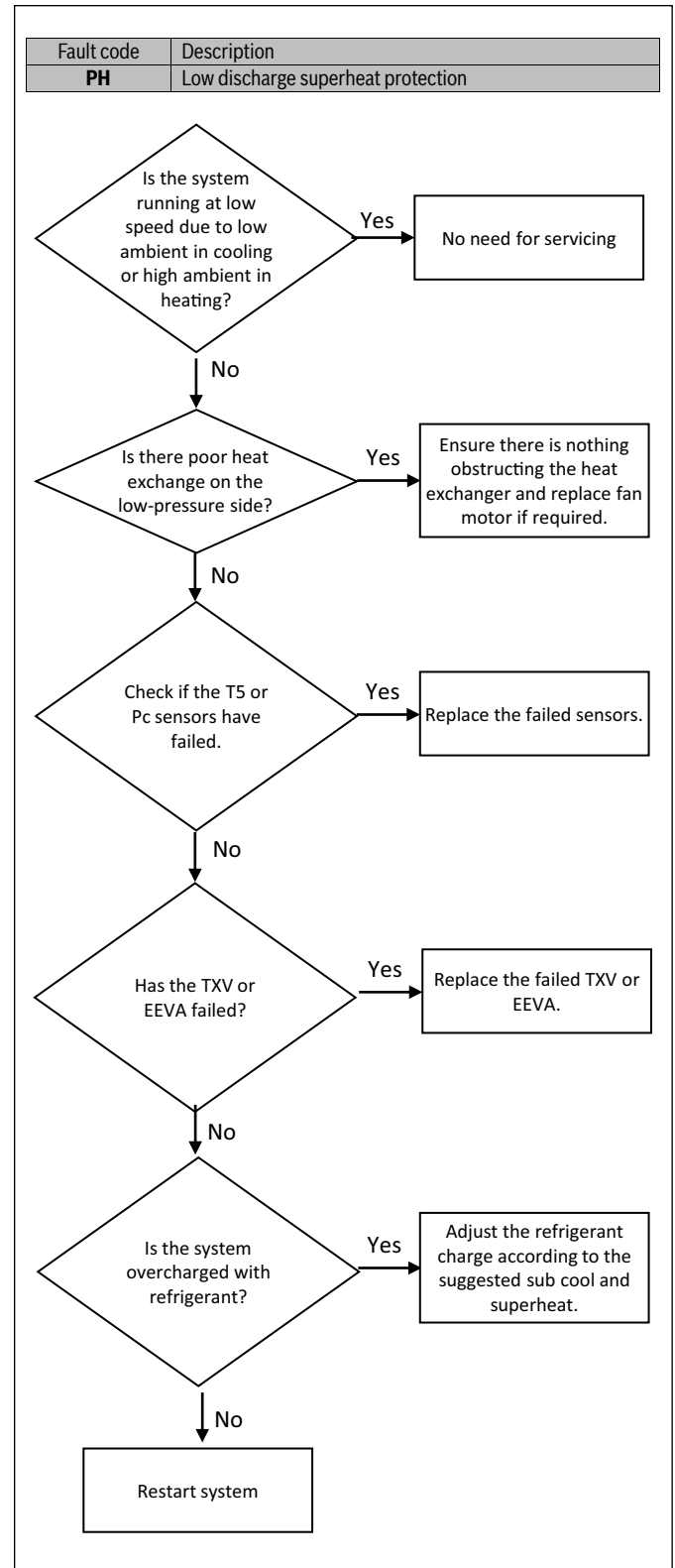

Figure 116

**18.13.1 Online Help Resources**

Alternatively, please visit our Service & Support webpage to find FAQs, videos, service bulletins, and more; [www.boschheatingcooling.com/service](http://www.boschheatingcooling.com/service) or use your cellphone to scan the code below.

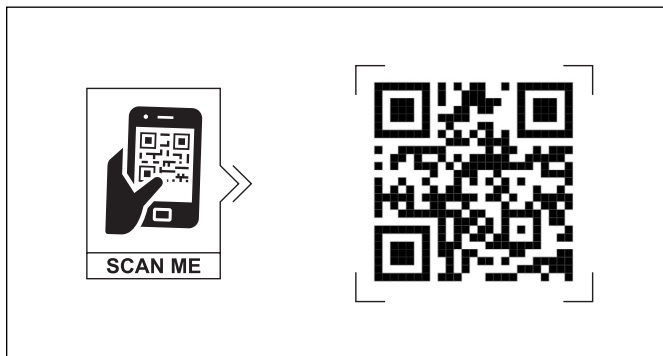

Figure 117

**18.14 Temperature and Resistance Relationship Tables (for Sensors)**

Temp (°F)	Temp (°C)	Resistance (kΩ)
-20	-28.89	218.11
-15	-26.11	154.74
-10	-23.33	129.74
-5	-20.56	107.73
0	-17.78	99.54
10	-12.22	71.80
20	-6.67	49.65
30	-1.11	36.71
40	4.44	27.39
50	10.00	20.61
60	15.56	15.65
70	21.11	11.99
80	26.67	9.27
90	32.22	7.23
100	37.78	5.68
110	43.33	4.51
120	48.89	3.61
130	54.44	2.90
140	60.00	2.35
150	65.67	1.91
160	71.11	1.57
170	76.67	1.28
180	82.22	1.00
190	87.78	0.91
200	93.33	0.76
210	98.89	0.65
220	104.44	0.56

Table 24 for T3, T3L, T4, T6A, T6B, T7, T1, T2 sensors

### 18.15 Temperature and Resistance Relationship Tables (for T5 Sensors)

Temp (°F)	Temp (°C)	Resistance (kΩ)
-20	-28.89	862.00
-15	-26.11	725.82
-10	-23.33	612.41
-5	-20.56	600.13
0	-17.78	505.55
10	-12.22	362.74
20	-6.67	265.40
30	-1.11	195.60
40	4.44	146.70
50	10.00	110.71
60	15.56	84.47
70	21.11	65.41
80	26.67	50.90
90	32.22	40.15
100	37.78	31.81
110	43.33	25.51
120	48.89	20.53
130	54.44	16.71
140	60.00	13.64
150	65.67	11.21
160	71.11	9.31
170	76.67	7.75
180	82.22	6.50
190	87.78	5.47
200	93.33	4.65
210	98.89	3.95
220	104.44	3.38

Table 25 for T5

**19 Wiring Diagram**

**WARNING**  
**ELECTRIC HAZARD 380 VOLTS DC**  
 WAIT 5 MINUTES AFTER DISCONNECTING POWER, THEN VERIFY DC VOLTAGE IS LESS THAN 42 VDC AT INVERTER TEST POINTS P-N. COMPONENTS MAY STORE A DANGEROUS ELECTRICAL POTENTIAL OF 380 VOLTS DC. FAILURE TO FOLLOW THIS WARNING COULD RESULT IN PERSONAL INJURY OR DEATH.

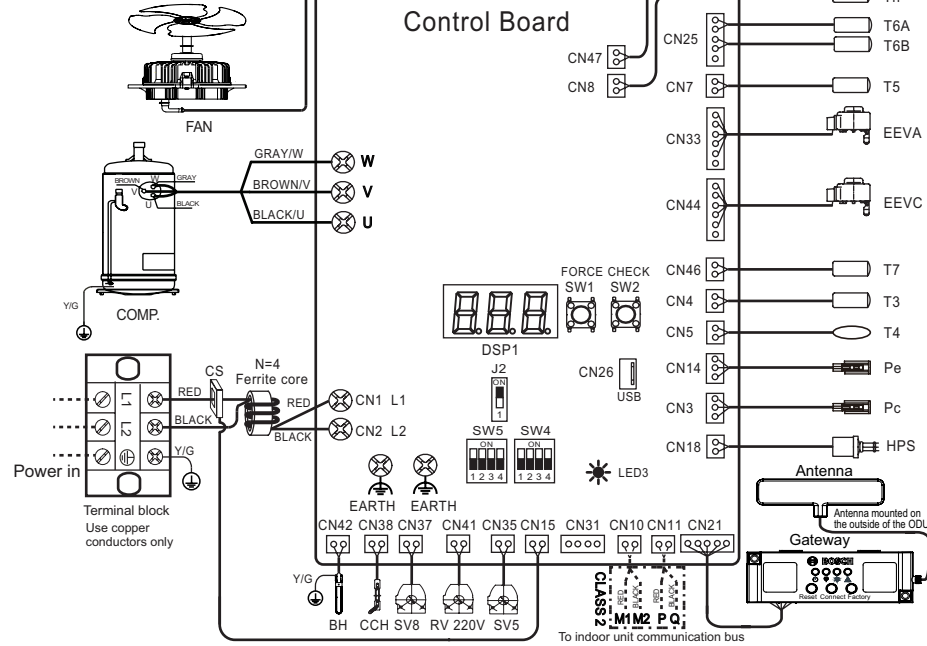

HPS	High pressure switch
Pc	High pressure sensor
Pe	Low pressure sensor
T4	Ambient temp. sensor
T3	Outdoor coil temp. sensor
T3L	Outdoor coil outlet temp. sensor
EEVC	C electronic expansion valve
EEVA	A electronic expansion valve
T5	Comp. discharge temp. sensor
T6A	Injection inlet of the plate heat exchanger temp. sensor
T6B	Injection outlet of the plate heat exchanger temp. sensor
Th	Comp. suction temp. sensor
T7	Outdoor outlet temp. sensor
SV5	Solenoid valve 5
RV	Reversing valve
SV8	Solenoid valve 8
CCH	Compressor crankcase heater
BH	Basepan heater
CS	Current sensor
COMP.	Compressor
Temp.	Temperature
ODU	Outdoor unit
IDU	Indoor unit

CODE	Fault description
AIL	Ambient temperature limited (T4)
b1	Temperature sensor fault in IDU (T1)
b2	Temperature sensor fault in IDU (T2)
b3	R454B refrigerant sensor fault in IDU
b4	R454B refrigerant sensor communication fault in IDU
b5	Communication fault between IDU and ODU
bF	Furnace driver board fault
b6	Power consumption sensor fault in IDU
b7	R454B refrigerant leakage protection in IDU
b8	R454B refrigerant sensor out of service life in IDU
b9	Indoor unit DIP switch does not match R454B refrigerant sensor
C3	Coil sensor mislocated or loose contact with sensor seat (T3)
E41	Temperature sensor fault (T3)
E42	Temperature sensor fault (T3L)
E43	Temperature sensor fault (T4)
E44	Temperature sensor fault (T5)
E45	Temperature sensor fault (Th)
E46	Temperature sensor fault (T6A)
E47	Temperature sensor fault (T6B)
E48	Temperature sensor fault (T7)
E49	Basepan heater fault
E51	IDU high/low incoming voltage protection
E52	ODU high/low DC bus voltage protection
E7	Compressor discharge sensor mislocated or loose contact with sensor seat (T5)
E81	EEVA solenoid coil fault
E82	EEVC solenoid coil fault
EA	Control program does not match drive program in ODU
F1	High pressure switch fault (HPS)
F2	5 times (P21) protection in 100 minutes, system lockout
F41	High pressure sensor fault
F42	Low pressure sensor fault
H01	Drive chip communication fault in ODU
H04	Chip of power consumption sensor communication fault in ODU
H14	Power consumption sensor fault in ODU
J00-JCF	Compressor drive protection
n00-nCF	Fan drive protection
P0	Compressor IPM temperature protection
P1	High pressure protection by HPS
P11	High pressure protection in cooling/heating (Pc)
P21	Low pressure protection in cooling/heating (Pe)
P31	ODU over current protection
P32	Compressor over current protection
P4	High compressor discharge temperature protection (T5)
P5	Condenser coil temperature protection in cooling (T3)
Pb1	Hyper-Link(M1M2) over current protection
PH	Low discharge superheat protection

* LED2 RED	Solid ON	Compressor running
	2s ON 2s OFF	Standby
	0.2s ON 0.2s OFF	Communication fault with control chip
	Blink	Driver fault
* LED3 RED	Solid ON	M1 and M2 short circuit
	OFF	Normal

Note:  
 1. M1M2 or PQ is connected to indoor unit in communication mode.  
 2. Only one part of CN10, and CN11 can be connected to IDU.  
 3. Dash-dotted line means optional.  
 4. Dotted line means field installed.

Number	Point check content
0	Outdoor unit capacity: H5=Heat pump 5 ton
1	Outdoor unit mode: 0-standby, 2-cooling, 3-heating
2	Outdoor unit set compressor speed (Hz)
3	System last fault code
4	Liquid valve subcooling (°F)
5	Gas valve superheat (°F)
6	T3: outdoor coil temp. (°F)
7	T3L: outdoor coil outlet temp. (°F)
8	T4: outdoor ambient temp. (°F)
9	T5: compressor discharge temp. (°F)
10	Th: compressor suction temp. (°F)
11	T7: outdoor outlet temp. (°F)
12	T6A: injection inlet of the plate heat exchanger temp. (°F)
13	T6B: injection outlet of the plate heat exchanger temp. (°F)
14	Compressor IPM temp. (°F)
15	Pe: evaporating pressure (psig)
16	Pc: condensing pressure (psig)
17	Te: target evaporating temp. (°F) (only for cooling mode)
18	Tc: evaporating temp. (°F)
19	Tcs: target condensing temp. (°F) (only for heating mode)
20	Tc: condensing temp. (°F)
21	Target value of the compressor discharge superheat (°F) (only for heating mode)
22	Compressor discharge superheat (°F)
23	Compressor suction superheat (°F)
24	Openings of EEVA (P)
25	Openings of EEVC (P)
26	Fan speed stage
27	ODU fan current (A)
28	Compressor current (A)
29	ODU current (A)
30	ODU incoming voltage (V)
31	ODU DC bus voltage (V)
32	ODU power (*0.1kW)
33	Continuous running time of the compressor (min)
34	ODU main control software version
35	IDU motor power (W) (only for communication mode)
36	IDU heat kit staging (only for communication mode)
37	T1: IDU ambient temp. (°F) (only for communication mode)
38	T2: IDU coil temp. (°F) (only for communication mode)
39	IDU software version (only for communication mode)
40	DR function setting
41	Reserved
42	Remark"-"

* The factory default	
SW4	ON OFF
SW5	ON OFF
J2	ON OFF

Gateway button descriptions  
 Reset Powers gateway off and back on  
 Connect Activates bluetooth(hold for at least 4 secs)  
 Factory Hold for 3-5 secs to run gateway in diagnostic mode  
 Diagnostic Check: After holding down the factory button (3-5 secs), press connect button to run full diagnostics. If there are any faults on the gateway, the Fault LED will flash accordingly.  
 Gateway light indications and descriptions

SW4-1	ON OFF	Unused Reserved *
SW4-2	ON OFF	Accelerated cooling/heating Normal *
SW4-3	ON OFF	Accelerated cooling/heating 2 Normal *
SW4-4	ON OFF	Adaptive capacity output disable Normal *
SW5-1	ON OFF	Heating time reduced 10% Normal *
SW5-2	ON OFF	Defrosting extended for 60 seconds Normal *
SW5-3	ON OFF	Reserved Normal *
SW5-4	ON OFF	Reserved Communication mode *

FORCE SW1	PRESS 1s	Forced cooling/heating (Charge mode)
CHECK SW2	PRESS 6s	Forced defrosting
	PRESS 1s	Check the system parameters

CODE	Description
-	Forced operation mode
(top)	Running indication under high pressure limited condition
(bottom)	Running indication under low pressure limited condition
A	Running indication under return oil mode
c	Running indication under current limited condition
d	Running indication under T5 limited condition
r	Running indication under COMP. IPM temp. limited condition
f	Running indication under compressor ratio limited condition
U	Running indication under low voltage limited condition
dF	Running indication under defrost mode
o31	Refrigerant amount indication: no result
o32	Refrigerant amount indication: significantly overcharge(reserved)
o33	Refrigerant amount indication: slightly overcharge
o34	Refrigerant amount indication: normal
o35	Refrigerant amount indication: slightly insufficient
o36	Refrigerant amount indication: significantly insufficient

Note: o31-o36 are only valid in force cooling mode.

Figure 118

## 20 IDS Ultra Gateway Functionality

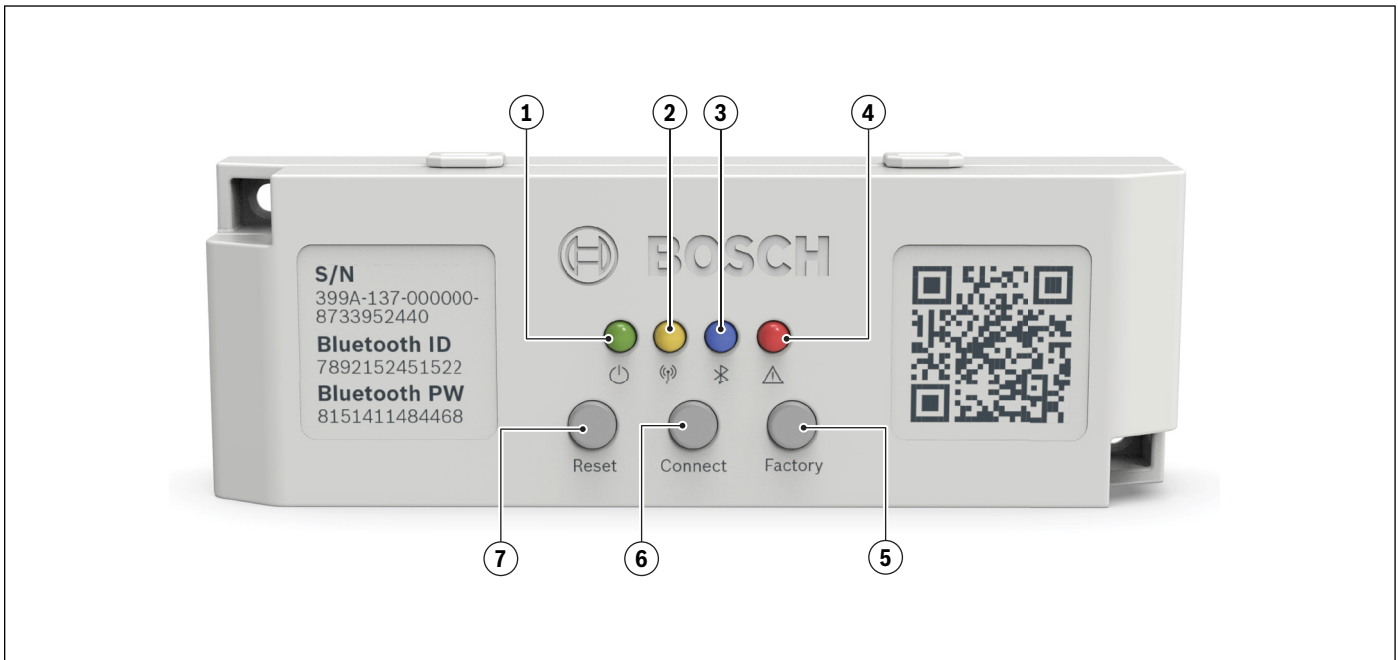

Figure 119

1. Power LED
2. Cellular LED
3. Bluetooth LED
4. Fault LED
5. Factory (Diagnostic) Button
6. Connect (Bluetooth) Button
7. Reset Button



The Gateway Assembly includes the Gateway and Antenna, along with associated wiring harness and clips.

## 21 Care and Maintenance

### 21.1 Cleaning Precautions



**WARNING**

**Maintenance and repair!**

Any maintenance and cleaning of outdoor unit must be performed by qualified service personnel only.

Any unit repairs must be performed by qualified service personnel only.



**CAUTION**

**Electric shock!**

Always turn off your heat pump and disconnect the power supply before cleaning or maintenance. Qualified service personnel only.

**NOTICE**

**Cleaning!**

Do not use chemicals or chemically treated cloths to clean the unit .

Do not use benzene, paint thinner, polishing powder or other solvents to clean the unit. Only clean water is recommended.



**CAUTION**

**Personal injury!**

When removing filter, do not touch metal parts in the unit. The sharp metal edges can cut you.

### 21.2 Maintenance – Pre-Season Inspection

At the beginning of each heating or cooling season, the following is required:

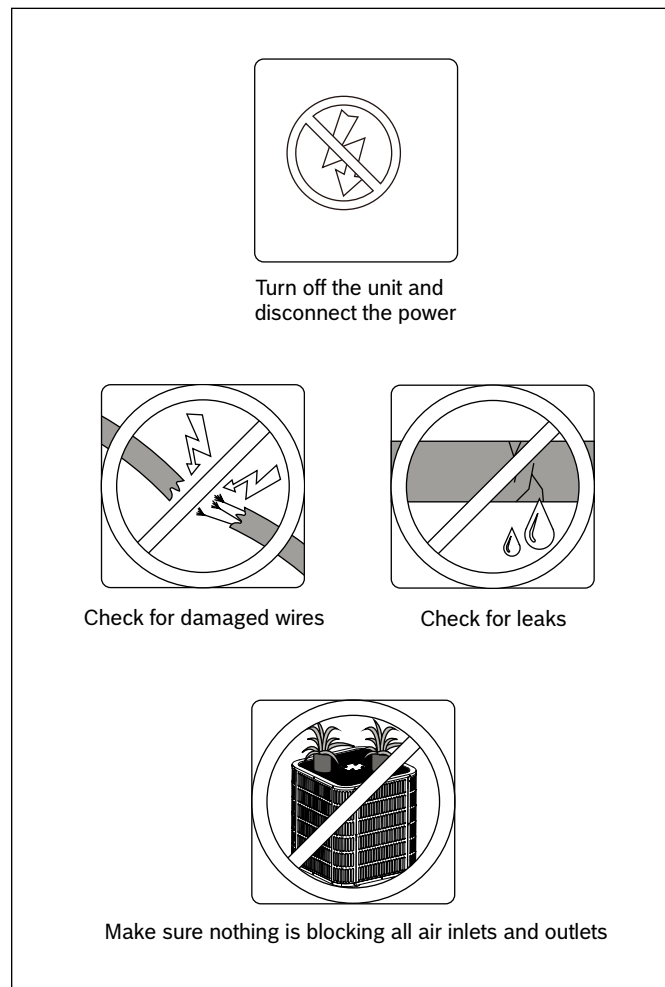

Figure 120

## 22 Disposal



**WARNING**

**Disposal!**

Disposal of unit or components must be performed by qualified service personnel only .

Components and units must be properly disposed in accordance with federal or local regulations.

Components and accessories from the units are not part of ordinary domestic waste.

Complete units , compressors, motors etc. are only to be disposed of via qualified disposal specialists.

This unit uses hydrogen fluorocarbons. Please contact the dealer when you want to dispose of this unit. Law requires that the collection, transportation and disposal of refrigerants must conform with the regulations governing the collection and destruction of hydrofluorocarbons.

**United States and Canada  
Bosch Thermotechnology Corp.  
65 Grove St.  
Watertown, MA 02472**

**Tel: 800-283-3787  
[www.bosch-homecomfort.us](http://www.bosch-homecomfort.us)**

**BTC 762003305 J / 02.2026**

**Bosch Thermotechnology Corp. reserves the right to  
make changes without notice due to continuing  
engineering and technological advances.**

**Version Française**

