

# Installation Guide

## Steel Valve with Air-Vent for Convectors

### 1 Installation in Convector

Built-in valve, type RA-N, code no. 013G8370

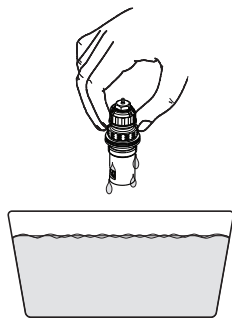

Lubricate valve insert by dipping in water.

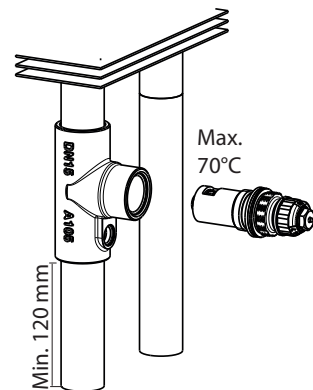

Insert the built-in valve into the steel valve housing

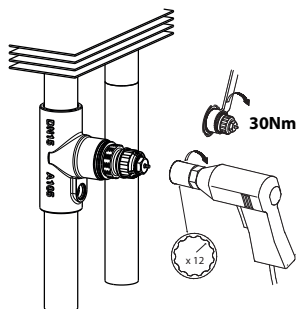

Fasten built-in valve with a torque of 30 Nm +/- 10%. 21M spanner.

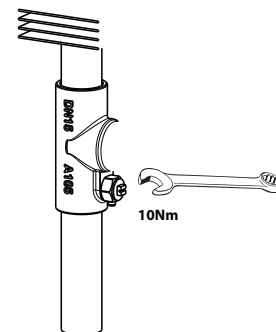

Fasten air-vent with a torque of 10 Nm +/- 10%. 13M spanner.

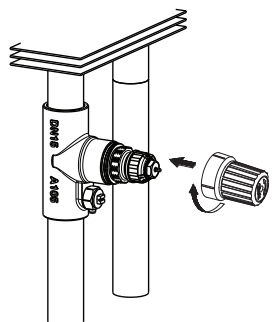

5. Fit protection cap. Tighten cap.

## 2 Replacement of Gland Seal

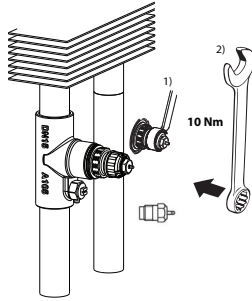

Replace the gland seal, code no. 013L0669. Can be done without draining the heating system.

<sup>1)</sup> 17M spanner for fixing the setting dial, <sup>2)</sup> 10M spanner.

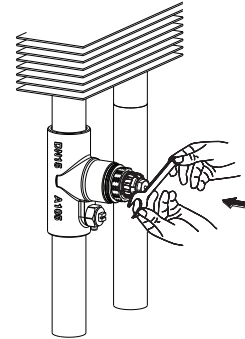

Test operation of valve spindle, by pushing the pin.