



IMPORTANT NOTICE - READ CAREFULLY

40 & 740 Series Copper Meter Insetters

- A. Prior to installation, verify setter dimensions are suitable for meter threads and laying length.
- B. The C-Style Meter Setter is designed to seal on the flared copper face and the brass endpiece nose face.
- C. **THE CUTOUT LENGTH IS CRITICAL:** too large of a space in rigid piping may not allow endpiece to seal on flared copper face (See Diagram).
- D. Do not use thread sealant on the sealing area or the endpiece nut threads.
- E. When tightening down the union nuts they must be tightened to a minimum 40 ft-lbs. of torque to ensure proper sealing in all installations. **PROPER INSTALLATION WILL CAUSE AN INDENTED CIRCLE ON THE FLARED COPPER FACE TO APPEAR.**
- F. Four gaskets are furnished with each meter setter, two for connecting the meter and two for connecting the end piece joint (see diagram).
- G. DO NOT use Vaseline®, plumber's grease, or any other petroleum based product on seals or o-rings.
- H. For ease of installation, the meter spacing for the meter is designed to have clearance for the meter and two gaskets. Hand tighten **BOTH** meter nuts **SIMULTANEOUSLY**. Then, alternating between meter nuts, wrench tighten to assure a positive seal. Excess tightening may damage the gasket and cause leakage.
- I. If a pipe nipple is to be used as an idler bar, it is recommended that a schedule 80 pipe nipple be selected and that care is exercised in tightening the swivel nut. Excess tightening may damage the gasket and cause leakage. If the gasket is damaged, discard and replace it with a new one.
- J. All joints should be pressure tested for leaks before leaving the installation location.

(OVER)

40 & 740 Series Copper Meter Insetters

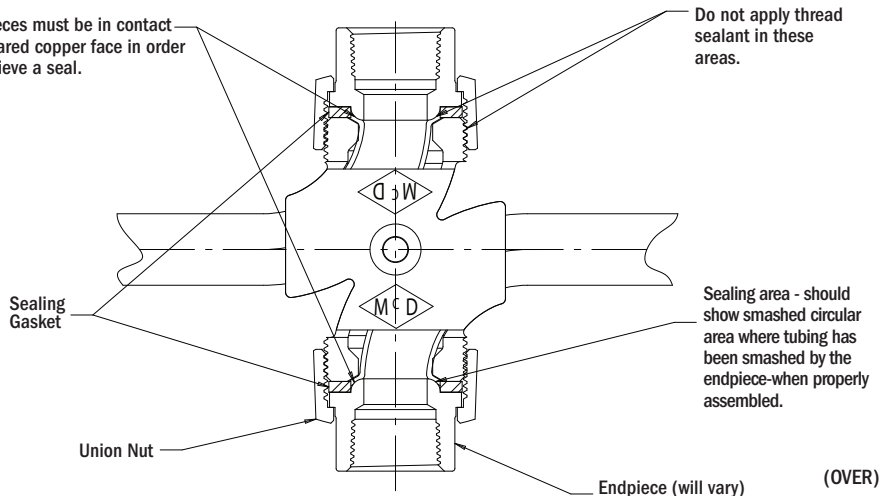

WARNING: It is unlawful in CALIFORNIA & VERMONT (effective 1/1/2010); MARYLAND (effective 1/1/2012); LOUISIANA (effective 1/1/2013) and the UNITED STATES OF AMERICA (effective 1/4/2014) to use any product in the installation or repair of any public water system or any plumbing in a facility or system that provides water for human consumption if the wetted surface area of the product has a weighted average lead content greater than 0.25%. This prohibition does not extend to service saddles used in California, Louisiana or under USA Public Law 111-380.