

# Installation Instructions

## THERMAL EXPANSION VALVE (TXV) KIT FOR HEAT PUMP AND AIR CONDITIONING

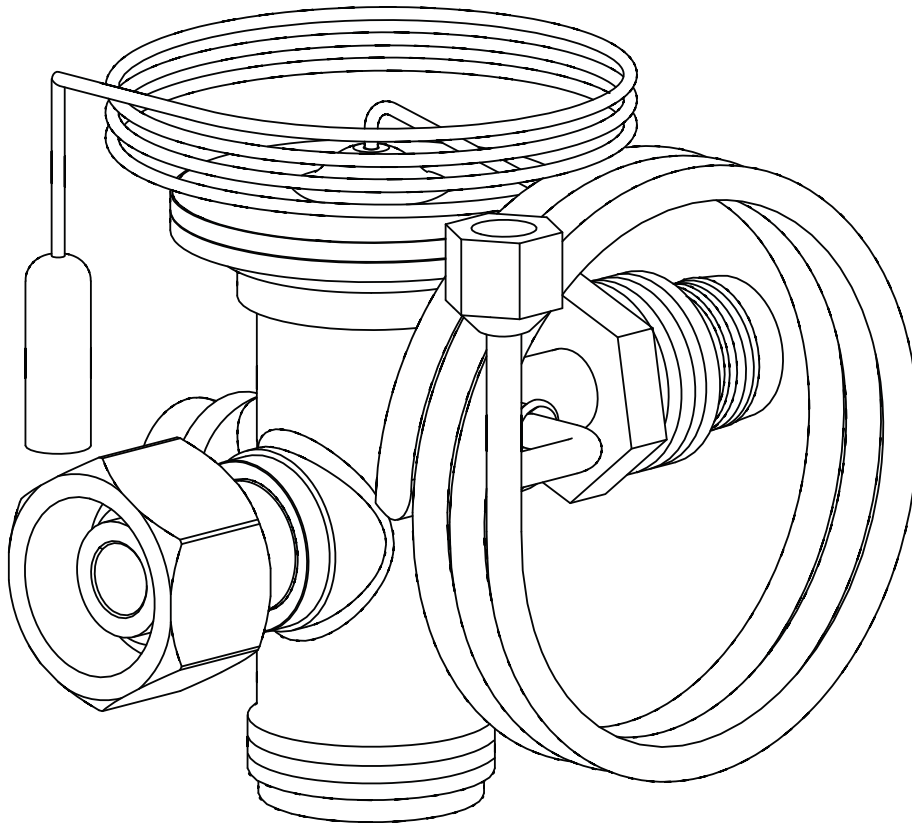

### SAFETY INFORMATION

**IMPORTANT:** Please read all instructions before servicing this equipment. Pay attention to all safety warnings and any other special notes highlighted in the manual. Safety markings are used frequently throughout this manual to designate a degree or level of seriousness and should not be ignored. **WARNING** indicates a potentially hazardous situation that if not avoided, could result in personal injury or death. **CAUTION** indicates a potentially hazardous situation that if not avoided, may result in minor or moderate injury or property damage.

### **WARNING:**

Improper installation, service, adjustment, or maintenance may cause explosion, fire, electrical shock or other hazardous conditions which may result in personal injury or property damage. Unless otherwise noted in these instructions, only factory authorized kits or accessories may be used with this product.

### **WARNING:**

Read the Installation Instructions supplied with the furnace/air handler. Always observe all safety requirements outlined in this manual and on the furnace/air handler markings before installing the valve.

### **WARNING:**

**PROPOSITION 65 WARNING: THIS PRODUCT CONTAINS CHEMICALS KNOWN TO THE STATE OF CALIFORNIA TO CAUSE CANCER, BIRTH DEFECTS OR OTHER REPRODUCTIVE HARM.**

SAFETY INFORMATION .....	Front Cover
GENERAL INFORMATION .....	2
PRE - INSTALLATION .....	2
INSTALLATION W/ C5 COILS .....	2
INSTALLATION W/ C6 COILS .....	4
COMPLETING THE INSTALLATION .....	6

## GENERAL INFORMATION

The thermal expansion valve kit is designed for use in air conditioner and heat pump systems. The kit consists of a thermal expansion valve with an external equalizer, a copper fitting assembly (for external equalizer), and sensing bulb clamp. Once installed, the TXV will adjust the refrigerant flow by monitoring the superheat of the system. See Table 1 to determine the proper kit based on the refrigerant type and tonnage of the unit.

- If precise forming of refrigerant lines is required, a copper tubing bender is recommended. Avoid sharp bends and contact of the refrigerant lines with metal surfaces.
- Refrigerant lines should be wrapped with pressure sensitive neoprene or other suitable material where they pass against sharply edged sheet metal.
- It is good practice to add a drop of refrigerant oil on all threaded connections.

	Kit P/N	Size of A.C. or Heat Pump
R22 REFRIGERANT	920662	1.5 ton or 2 tons
	920663	2.5
	920664	3
	920665	3.5
	920666	4
	920667	5
R410A REFRIGERANT	920668	1.5 ton or 2 tons
	920669	2.5
	920670	3
	920671	3.5
	920672	4
	920673	5

Table 1. Kit Part Numbers

## PRE-INSTALLATION

### ! WARNING:

**Shut off all electrical power to the furnace and outdoor condensing unit before performing any maintenance or service on the system.**

1. Disconnect all electrical power to the furnace/air handler. **IMPORTANT NOTE: The unit may have more than one power supply. Refer to the manufacturer's instructions for additional electrical information.**
2. Remove coil access door from indoor unit (if applicable) to expose the A-coil and distributor. **NOTE: It may be necessary to remove the coil from the coil case.**
3. Recover all refrigerant in the system (if applicable).

## INSTALLATION WITHIN C5 COILS

### ! WARNING:

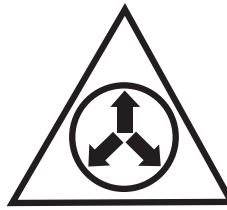

NITROGEN	
HEALTH	1
FLAMMABILITY	0
REACTIVITY	0
0 Minimal Hazard 1 Slight Hazard	

**The coil is pressurized with Nitrogen. Avoid direct face exposure or contact with valve when gas is escaping. Always ensure adequate ventilation is present during the depressurization process. Any uncertainties should be addressed before proceeding.**

### ! CAUTION:

**To prevent damage to the unit or internal components, it is recommended that two wrenches be used when loosening or removing nuts. Do not over tighten!**

1. Using two wrenches, loosen the distributor and liquid line body halves. Turn the assembly nut counter-clockwise.
2. Unscrew the swivel nut and **remove the fixed orifice** (Figure 1) from the distributor.
3. Install the thermal expansion valve between the distributor and the 3/8 liquid line (Figure 2, page 3).
  - a. Connect the liquid line to the inlet side of the valve.
  - b. Connect the distributor to the outlet side of the valve.
  - c. Using two wrenches, tighten both ends of the valve.

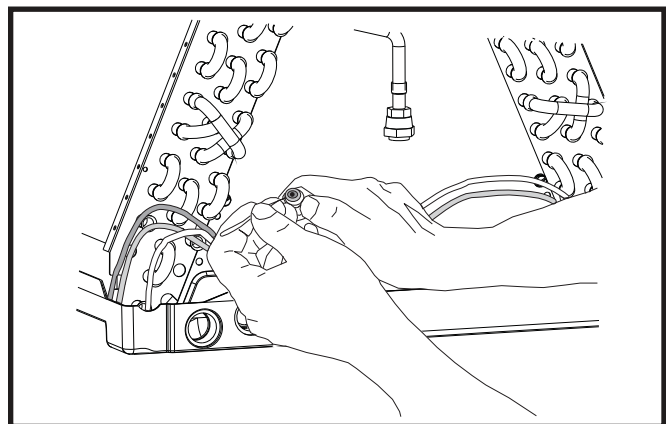
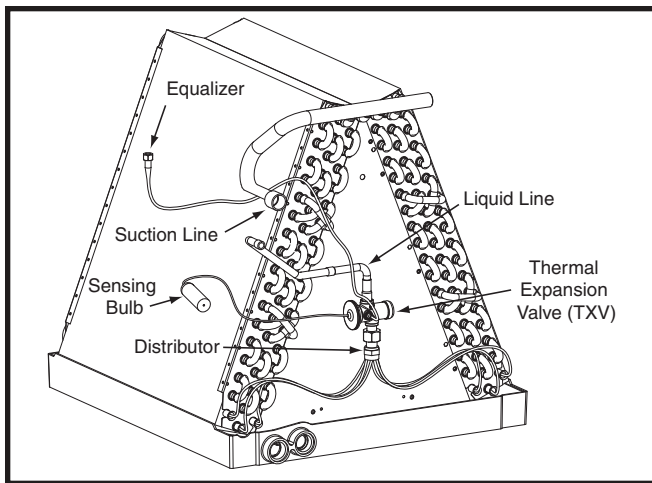

Figure 1. Distributor and Orifice

4. Modify the close off plate by bending back a section of the top right corner (Figure 3, page 3). **NOTE: This will allow the external equalizer and sensing bulb to reach the refrigerant lines outside of the coil box.**



**Figure 2. C5 Coil With TXV Installed**

5. Reinstall the close off plate and route the sensing bulb and external equalizer through the opening.
6. Install the grommet in the suction line hole of the close off plate. Verify the grommet is evenly aligned around the tube and securely positioned.

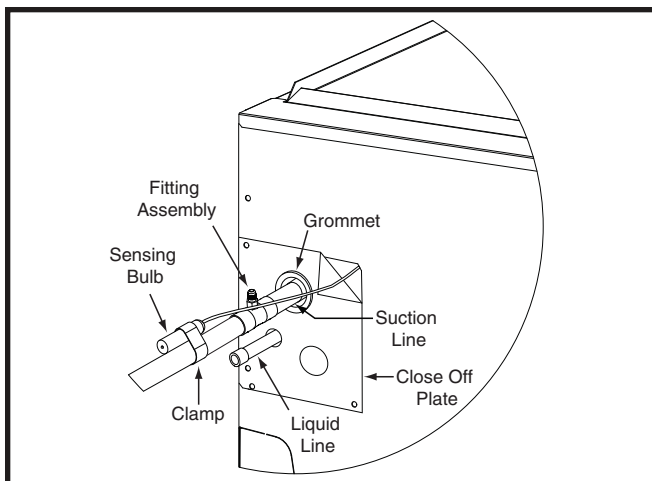

**Figure 3. Sensing Bulb Mounted Externally**

7. Install the fitting assembly that is supplied with the kit on the end of the suction line.

**IMPORTANT NOTES:**

- The fitting assembly must be positioned close enough to the indoor coil so that the external equalizer tube from the TXV can reach the fitting, but still allow room for the sensing bulb to fit flush against the suction line without hitting the braze joint of the external equalizer.
- Position the fitting assembly on the suction line so that the 1/4" access fitting is pointing vertically. If the access fitting is pointed downwards, oil from the suction line will drain into the external equalizer.
- Depending on the suction line diameter, two reducers may need to be added to the suction line before the fitting assembly is brazed on.

---

**! CAUTION:**

---

It is recommended that a wet rag be wrapped around the suction line in front of the close off plate before applying heat. Failure to keep components cool during brazing may result in structural damage, premature equipment failure, or possible personal injury.

---

8. Route and cut both lineset tubes to proper length in accordance with the outdoor unit specifications. Verify the ends are round, clean, and free of any burrs.
- 

**! CAUTION:**

---

To prevent damage to the TXV, brazing should be done prior to the attachment of the liquid line to the fitting assembly.

---

9. Braze the fitting assembly, reducers (if applicable), and individual lineset connections together with dry nitrogen flowing through the joints. This will prevent internal oxidation and scaling from occurring.
10. Install the external equalizer and sensing bulb.

**IMPORTANT NOTES:**

- The sensing bulb must be located flush against the suction line for optimum heat transfer.
- Avoid attaching the sensing bulb to the lowest part of the suction line where condensate may accumulate.
- Do not locate the sensing bulb on vertical sections of the lineset.
- For horizontal lines, the bulb should not be located at 12 or 6 o'clock position of the suction line. The best location is at 4 or 8 o'clock.
- The external equalizer and sensing bulb may be installed on the refrigerant lines outside of the coil cabinet. Both tubes will need to pass through the close off plate to get to the outside of the coil cabinet.
- For additional information on proper sensing bulb locations, please refer to the valve manufacturer's instructions.
  - a. Connect the equalization line from the TXV to the fitting assembly.
  - b. Secure the sensing bulb to the suction line using the clamp supplied with the kit.
  - c. Wrap the bulb and suction line together with tar tape or other insulating material.

## INSTALLATION WITHIN C6 COILS

### **WARNING:**

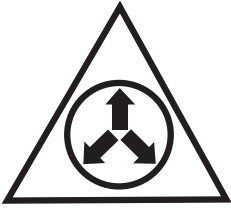

NITROGEN	
HEALTH	1
FLAMMABILITY	0
REACTIVITY	0
0 Minimal Hazard 1 Slight Hazard	

**This coil is pressurized with Nitrogen. Avoid direct face exposure or contact with valve when gas is escaping. Always ensure adequate ventilation is present during the depressurization process. Any uncertainties should be addressed before proceeding.**

1. Remove the cap (Figure 4) from the valve holder.
2. Verify coil pressurization by depressing the Schrader valve. Listen for any escaping gas. If there is no pressure, test the coil for leakage.
  - If leakage is found, clearly mark the location of the leak and return the coil to the distributor for processing.
  - If no leaks are found, the TXV may be installed.
3. Depress the valve until all pressure is released from the coil.

### **CAUTION:**

**To prevent damage to the unit or internal components, it is recommended that two wrenches be used when loosening or removing nuts. Do not over tighten!**

4. Using two wrenches, remove the valve holder nut from the liquid line. Keep the nut for future use.
5. Remove and discard the Schrader valve and valve holder from the liquid line. **NOTE:** Do not reuse the O-ring, valve, or threaded valve holder.
6. Remove the retaining nut securing the dogleg or bulkhead extension to the case (See Figure 4). Keep the retaining nut for future use.

### **CAUTION:**

**To prevent damage to the unit or internal components, it is recommended that two wrenches be used when loosening or removing nuts. Do not over tighten!**

7. Using two wrenches, loosen the distributor and bulkhead extension, turning the nut counter-clockwise.
8. Remove and discard the bulkhead extension from the distributor (cased coils only).
9. Route and cut the liquid lineset tube to proper length in accordance with the outdoor unit specifications. Verify the ends are round, clean, and free of any burrs.

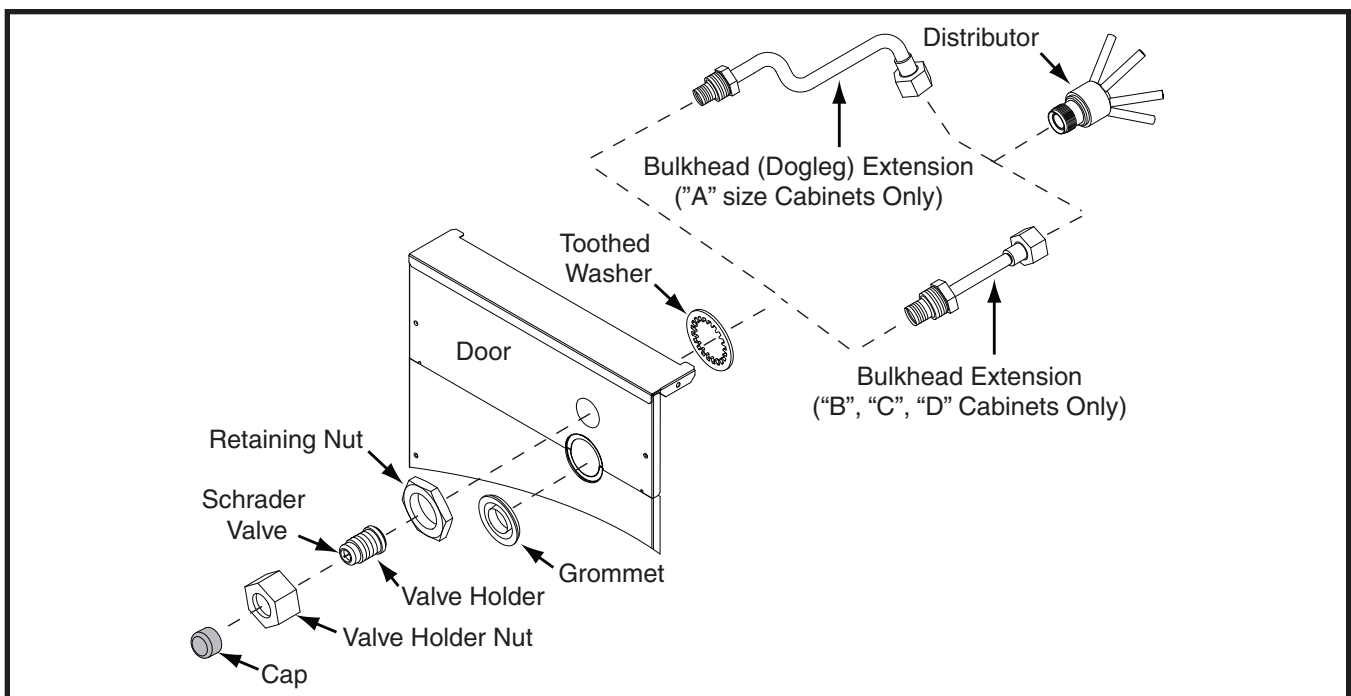

**Figure 4. C6 Coil Assembly As Shipped**

10. Install the accessory retaining nut and the liquid line stub onto the liquid lineset (Figure 5).
11. Braze the lineset and liquid line stub together with dry nitrogen flowing through the system. This will prevent internal oxidation and scaling from occurring.
12. Install the thermal expansion valve (Figure 5).
  - a. Fasten the outlet end of the TXV to the threaded end of the distributor.
  - b. Install the bulkhead fitting onto the end of the TXV (If applicable).
  - c. Install the internal toothed washer over the inlet end of the TXV or bulkhead fitting (if applicable).
  - d. Install the condensation deflector over the inlet end of the TXV or the bulkhead fitting (if applicable).
  - e. Insert the threaded end of the of the TXV or the bulkhead fitting (if applicable) thru the hole in the case.
  - f. Install the TXV retaining nut (removed earlier in step 6) onto the TXV or bulkhead fitting (if applicable).
  - g. Install the liquid line and retaining nut onto the end of the TXV or the bulkhead fitting (if applicable).

**⚠ CAUTION:**

**To prevent damage to the unit or internal components, it is recommended that two wrenches be used when loosening or removing nuts. Do not over tighten!**

- h. Using two wrenches, tighten all connections.

13. Install the external equalizer and sensing bulb.

**IMPORTANT NOTES:**

- **The sensing bulb must be located flush against the suction line for optimum heat transfer.**
- **Avoid attaching the sensing bulb to the lowest part of the suction line where condensate may accumulate.**
- **Do not locate the sensing bulb on vertical sections of the lineset.**
- **For horizontal lines, the bulb should not be located at 12 or 6 o'clock position of the suction line. The best location is at 4 or 8 o'clock.**
- **For additional information on proper sensing bulb locations, please refer to the valve manufacturer's instructions.**
  - a. Connect the equalization line (Figure 6, page 6) from the TXV to the 1/4 port located on the suction line.
  - b. Secure the sensing bulb to the suction line using the clamp supplied with the kit.
  - c. Wrap the bulb, clamp, and suction line together with tar tape or other insulating material.

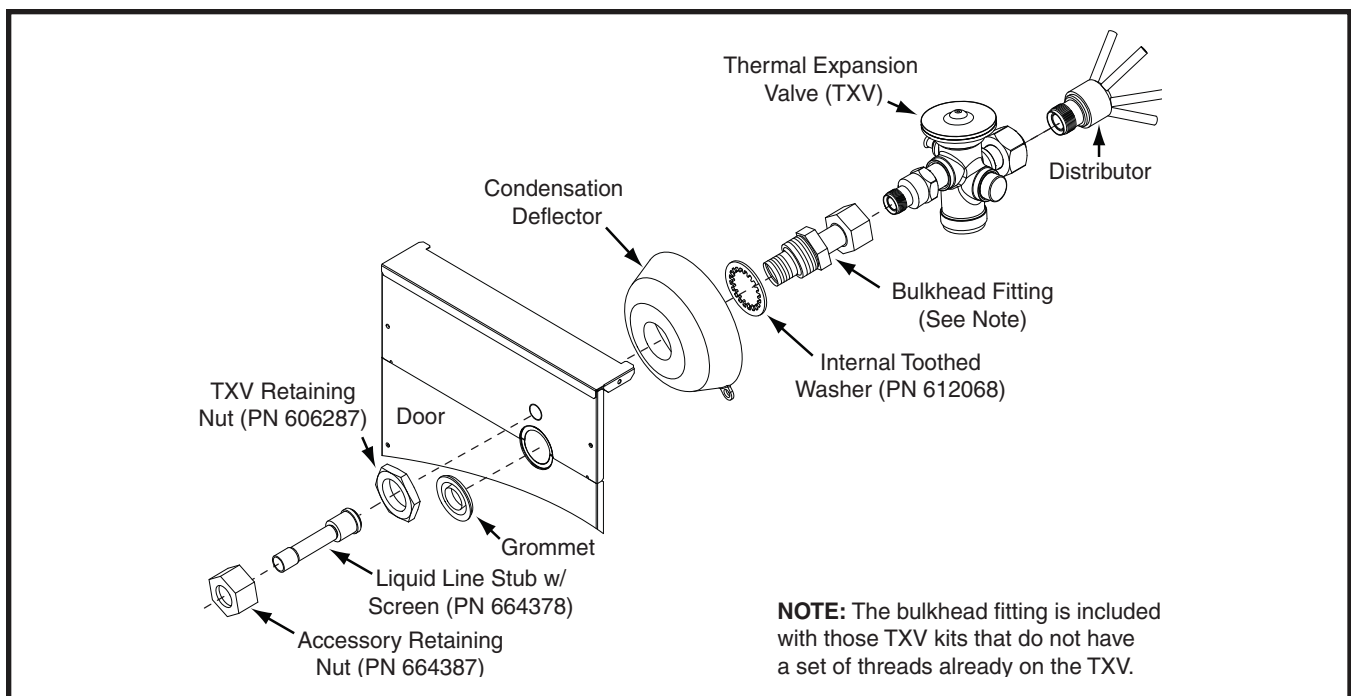

**Figure 5. TXV Assembly As Installed**

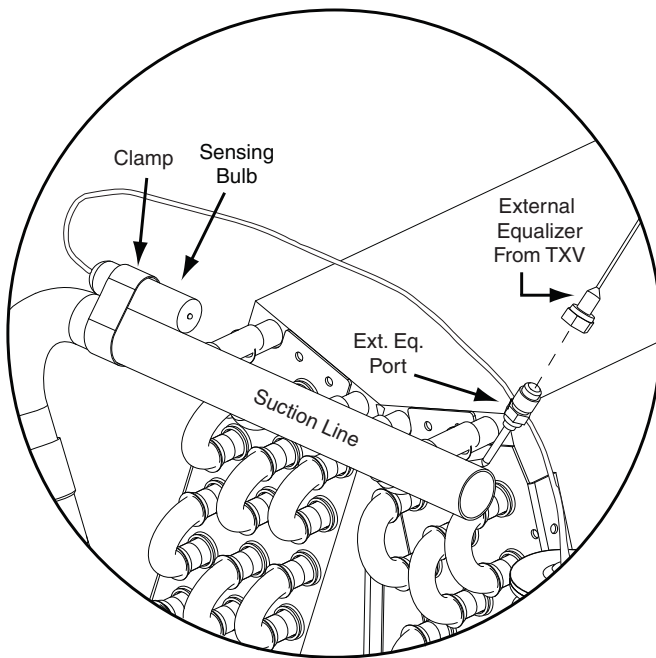

**Figure 6. Sensing Bulb and External Equalizer**

### **COMPLETING THE INSTALLATION**

1. Check the system for leaks, including the lineset and the brazed joints. Pressurize the system with nitrogen and apply a soap and water solution to each joint or union with a small paintbrush. **NOTE:** If bubbling is observed, the connection is not adequately sealed.
2. Evacuate the system of moisture and non-condensables to prevent low efficiency operation or damage to the unit. The suggested range of evacuation is 250 - 500 microns.
3. Charge the system with refrigerant. **Please Refer to the outdoor unit installation manual for charging instructions.**
4. Install the coil or coil access door if removed. Apply power to the unit.





The installer performing this work assumes all responsibility for this installation. These instructions are primarily intended to assist qualified individuals experienced in the proper installation of these components. Some local codes may require licensed installation/service personnel for this type of equipment. Safety should always be the deciding factor when installing this product and using common sense plays an important role as well. Improper installation of the components or failure to follow safety warnings could result in serious injury, death, or property damage. After completing the installation, return these instructions to the homeowner's package for future reference.

---

¢709003pα

**NORDYNE**  
O'Fallon, MO

7090030

**7090030**  
Specifications and illustrations subject to change  
without notice or incurring obligations.  
Printed in U.S.A. (02/09)