

Technical Data Manual

Model Nos. and pricing: see Price List



Vitodens 100-W

B1HE Series and B1KE Combi Series

Wall mounted gas-fired condensing boiler with 3.5 inch black/white display
On demand domestic Hot Water with Combi Boilers
For operation with natural gas or liquid propane gas

Heating Input: 8.5 to 199 MBH
2.5 to 58.3 kW



VITODENS 100-W



Product may not be exactly as shown

Gas-Fired Wall-Mounted Condensing Boiler with modulating stainless steel MatrixPlus cylinder burner, stainless steel radial heat exchanger for room air independent operation (using a direct vent system) or room air dependent operation.

B1KE comes equipped with an on demand hot water unit providing reliable hot water without a DHW tank.



Product Information

Equipped with a Viessmann stainless steel heat exchanger for lasting performance and reliability and a modulating MatrixPlus cylinder gas burner, the Vitodens 100-W wall-mounted condensing boiler is the perfect combination of value, quality and Viessmann technology.

The benefits at a glance:

- **Outstanding efficiency**
of 95.0% A.F.U.E. on all models.
- **Lasting performance**
with Viessmann-made SA240 / S43932 stainless steel Inox-Radial heat exchanger constructed to ASME Section IV and CSA B51.
- **Low-emission**
with fully-modulating stainless steel MatrixPlus cylinder burner. Factory calibration eliminates adjustments in the field.
< 20 ppm NO_x (at 3% O₂)
- **Control variety**
Integrated boiler control interfaces with any level of external control - from room thermostat to outdoor reset and more.
- **Compact, lightweight wall mount design**
and zero clearance to combustibles make it a great choice for limited-space installations.
- **Extremely quiet operation**
quieter than most refrigerators.
< 59 dBA [at 3.3 ft. (1 meter)]
- **Easy installation, service and maintenance**
with all pipe connections located at the bottom and serviceable components (including electrical connections) easily accessible from the front.
- **Multiple venting options**
 - Horizontal or vertical sealed combustion coaxial, PP(s) vent system (Viessmann supplied).
 - Horizontal, vertical or hybrid sealed combustion double-pipe CPVC vent system (field supplied).
 - Horizontal or vertical single pipe CPVC vent system (field supplied).
 - Horizontal or vertical single or double pipe PP(s), flexible vent system (Viessmann supplied).
- **Suitable for high altitude levels**
of up to 10,000 ft. (3,000 m).
- **Built-in automatic frost protection**
allows boiler to be shut off for an extended period of time while protecting it against freeze-up.
- **Reliable on demand domestic hot water (B1KE)**
 - Plate type heat exchanger
 - Built-in diverting valve
 - Built-in boiler pump
 - Built-in flow sensor
 - Built-in temperature sensor
 - Supplied with a pressure relief valve rated at 150 psi
- **Limited lifetime warranty**
in residential applications.
- The B1KE boiler conforms to NSF/ANSI 372 for “lead free” plumbing products as defined by applicable US state laws and by section 1417 of the US Safe Drinking Water Act.

Product Information

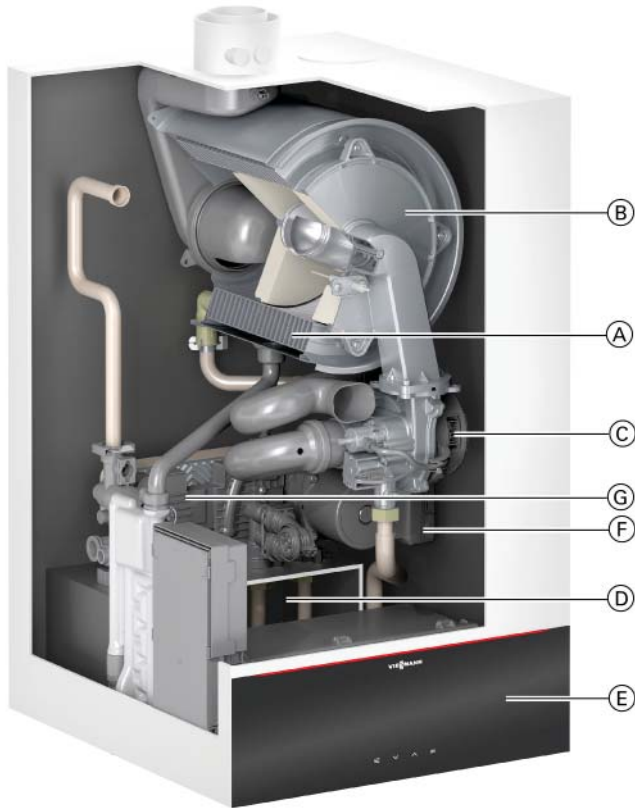

Standard Equipment:

Wall-mount condensing boiler and installation fittings c/w 30 psi pressure relief valve, pressure guage, two fill/drain valves, all mounting hardware, outdoor temperature sensor, and LPG conversion labelling kit.

Boiler cross-section

Legend

- Ⓐ Inox-Radial stainless steel heat exchanger
- Ⓑ Stainless steel MatrixPlus cylinder burner
- Ⓒ Burner blower
- Ⓓ Gas and hydronic connections
- Ⓔ Black and white 3.5 inch boiler control display
- Ⓕ High efficiency boiler/DHW production pump
- Ⓖ DHW plate heat exchanger (combi boilers only)

Specifications

Standard heating boiler

	Boiler Model No.	B1HE-85	B1HE-120	B1HE-150	B1HE-199	B1KE-120	B1KE-199
CSA input Natural gas (NG)	MBH	8.5-85	12-120	15.5-150	19.9-199	12-120	19.9-199
	kW	2.5-24.9	3.5-35.2	4.5-44.0	5.8-58.3	3.5-35.2	5.8-58.3
CSA input Liquid propane Gas (LPG)	MBH	14-85	14-120	22.7-150	22.7-199	14-120	22.7-199
	kW	4.1-24.9	4.1-35.2	6.7-44.0	6.7-58.3	4.1-35.2	6.7-58.3
CSA output/DOE *1 heating capacity NG	MBH	8-80	11-113	14-141	18.5-187	11-113	18.5-187
	kW	2.3-23.4	3.2-33.1	4.1-41.3	5.4-54.8	3.2-33.1	5.4-54.8
CSA output/DOE *1 heating capacity LPG	MBH	13-80	13-113	21-141	21-187	13-113	21-187
	kW	3.8-23.4	3.8-33.1	6.1-41.3	6.1-54.8	3.8-33.1	6.1-54.8
Net AHRI rating *2	MBH	70	98	123	163	98	163
	kW	20.5	28.7	36.0	47.8	28.7	47.8
Heat exchanger surface area	ft. ²	12.96	12.96	27.44	27.44	12.96	27.44
	m ²	1.20	1.20	2.55	2.55	1.20	2.55
Min. gas supply pressure							
	Natural gas	"w.c.	4	4	4	4	4
LPG	"w.c.	10	10	10	10	10	10
Max. gas supply pressure *3							
	Natural gas and LPG	"w.c.	14	14	14	14	14
A.F.U.E.	%	95	95	95	95	95	95
Weight	lbs	108	108	179	179	110	190
	kg	49	49	81	81	50	86
Shipping weight	lbs	143	143	218	218	146	229
	kg	65	65	99	99	66	104
Boiler water content	USG	1.02	1.02	2.5	2.5	1.02	2.5
	L	3.88	3.88	9.50	9.50	3.88	9.50
Boiler max. flow rate *4	GPM	4.8	6.2	8.8	10.6	6.2	10.6
	L/h	1090	1408	1999	2408	1408	1408
Max. operating pressure (max. allowable working pressure) at 210°F (99°C)	psig	45	45	60	60	45	60
	bar	3	3	4	4	3	4
Boiler water temperature							
	- Adjustable high limit (AHL) range						
	- space heating (steady state)	°F (°C)	68-180 (20-82)				
	- DHW tank heating	°F (°C)	194 (90)				
	- DHW heating	°F (°C)	194 (90)				
- Fixed high limit (FHL)	°F (°C)	210 (99)					
Boiler connections							
Boiler heating supply and return	NPTM (male)	¾ in	¾ in	1 in	1 in	¾ in	1 in
Pressure relief valve	NPTF (female)	¾ in	¾ in	¾ in	¾ in	¾ in	¾ in
DHW tank heating supply/return	NPTM (male)	¾ in	¾ in	1 in	1 in	-	-
DHW heating	NPTM (male)	-	-	-	-	¾ in	1 in
Drain valve	(male thread)	¾ in	¾ in	¾ in	¾ in	¾ in	¾ in
Dimensions							
Overall depth	inches	19 ¾	19 ¾	21 ¾	21 ¾	19 ¾	21 ¾
	(mm)	(500)	(500)	(550)	(550)	(500)	(550)
Overall width	inches	17 ¾	17 ¾	17 ¾	17 ¾	17 ¾	17 ¾
	(mm)	(450)	(450)	(450)	(450)	(450)	(450)
Overall height	inches	33 ¾	33 ¾	39	39	33 ¾	39
	(mm)	(859)	(859)	(989)	(989)	(859)	(989)

*1 Output based on 140°F (60°C), 120°F (49°C) system supply / return temperature.

*2 Net AHRI rating based on piping and pick-up allowance of 1.15.

*3 If the gas supply pressure exceeds the maximum gas supply pressure value, a separate gas pressure regulator must be installed upstream of the heating system.

*4 See "System Flow Rates" on page 11 in this manual.

Specifications *(continued)*

Standard heating boiler *(continued)*

	Boiler Model No.	B1HE-85	B1HE-120	B1HE-150	B1HE-199	B1KE-120	B1KE-199
Gas supply connection	NPTM (male)	¾ in	¾ in	¾ in	¾ in	¾ in	¾ in
Flue gas *5							
Temperature at boiler return temperature of 86°F (30°C)							
- at rated full load	°F (°C)	99 (37)	102 (39)	106 (41)	104 (40)	102 (39)	104 (40)
- at rated partial load	°F (°C)	95 (35)	95 (35)	111 (44)	113 (45)	95 (35)	113 (45)
Temperature at boiler return temperature of 140°F (60°C)	°F (°C)	144 (62)	145 (63)	151 (66)	149 (65)	145 (63)	149 (65)
Flue gas value							
Mass flow rate (of flue gas)							
- at rated full load	lbs/h	86.9	126.0	155.9	207.0	147.0	207.0
	kg/h	39.4	57.1	70.7	93.9	66.7	93.9
- at rated partial load	lbs/h	8.9	13.0	16.1	20.8	13.0	20.8
	kg/h	4.0	5.9	7.3	9.4	5.9	9.4
Available draught	Pa	250	250	250	250	114	250
	mbar	2.5	2.5	2.5	2.5	1.14	2.5
Flue gas temperature sensor limit	°F (°C)	230 (110)	230 (110)	230 (110)	230 (110)	230 (110)	230 (110)
Average condensate flow rate *6							
with natural gas							
- Ts/TR = 122 / 86°F (50 / 30°C)	USG/day	20.3	27.9	34.9	46.9	27.9	46.9
	L/day	76.8	105.6	132.0	177.6	124.8	196.8
Condensate connection *7	hose nozzle Ø in	¾ in	¾ in	¾ in	¾ in	¾ in	¾ in
Boiler flue gas connection *8	Ø in (mm)	3 (80)	3 (80)	3 (80)	3 (80)	3 (80)	3 (80)
Combustion air supply connection *8	coaxial outer single Ø in (mm) Ø in (mm)	5 (125) 3 (80)	5 (125) 3 (80)	5 (125) 3 (80)	5 (125) 3 (80)	5 (125) 3 (80)	5 (125) 3 (80)
Noise level (at 1 meter)							
- at full load	(dB)	52	59	51	55	59	55
- at partial load	(dB)	34	34	31	31	34	31
NOx @ 3% O₂ *9		< 20 ppm					

*5 Measured flue gas temperature with a combustion air temperature of 68°F (20°C).

*6 Based on typical boiler cycles, including partial load conditions.

*7 Requires ¾ in. (19 mm) tubing. See Vitodens 100-W Installation Instructions for details.

*8 For detailed information refer to the Vitodens Venting System Installation Instructions.

*9 The Vitodens 100 B1HE/B1KE boilers are certified to the requirements of South Coast Air Quality Management District (SCAQMD) Rule 1146.2, Bay Area Air Quality Management District (BAAQMD) Regulation 9 Rule 6, and San Joaquin Valley Air Pollution Control District (SJVAPCD) Rule 4308.

Specifications *(continued)*

B1KE on demand hot water operation

	Boiler Model No.	B1KE-120	B1KE-199
Max. Input NG and LPG (DHW production only)	MBH	140	199
	kW	41.0	58.3
Max. boiler temperature (during DHW production)	°F (°C)	194 (90)	194 (90)
DHW supply temperature	°F (°C)	140 (60)	140 (60)
Continuous draw rate * 1 at $\Delta t = 77^\circ\text{F}$ (43K)	USG/min.	3.3	4.7
	(L/h)	757	1070
Max. flow through heat exchanger	USG/min. (L/h)	3.7 (840)	5.3 (1200)
Maximum allowable working pressure (potable water)	psi	150	150
Test pressure	psi	300	300

*1 DCW and DHW temperature rise would be proportional. Maximum DHW supply temperature is 140°F (60°C).

B1KE DHW Performance

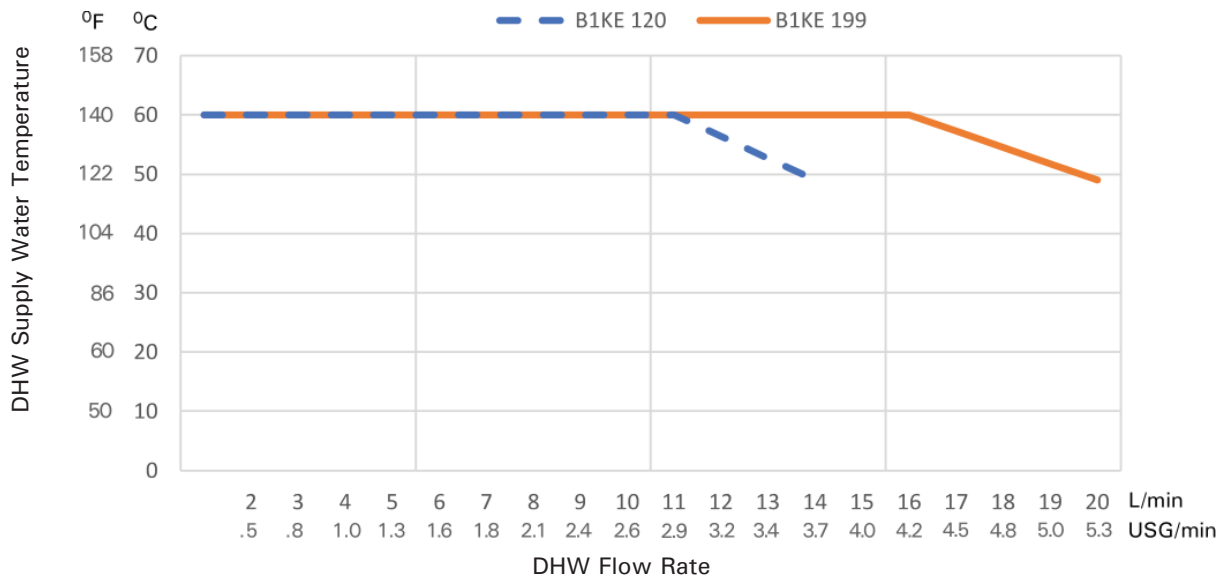

This chart illustrates the changes in the outlet temperature, subject to the flow rate at the tap. The curve is only applicable for a DCW inlet temperature of 50°F (10°C) and boiler input data stated in the above. Minimum flow through the heat exchanger for boiler start = 0.5 GPM.

Boiler Dimensions 85/120

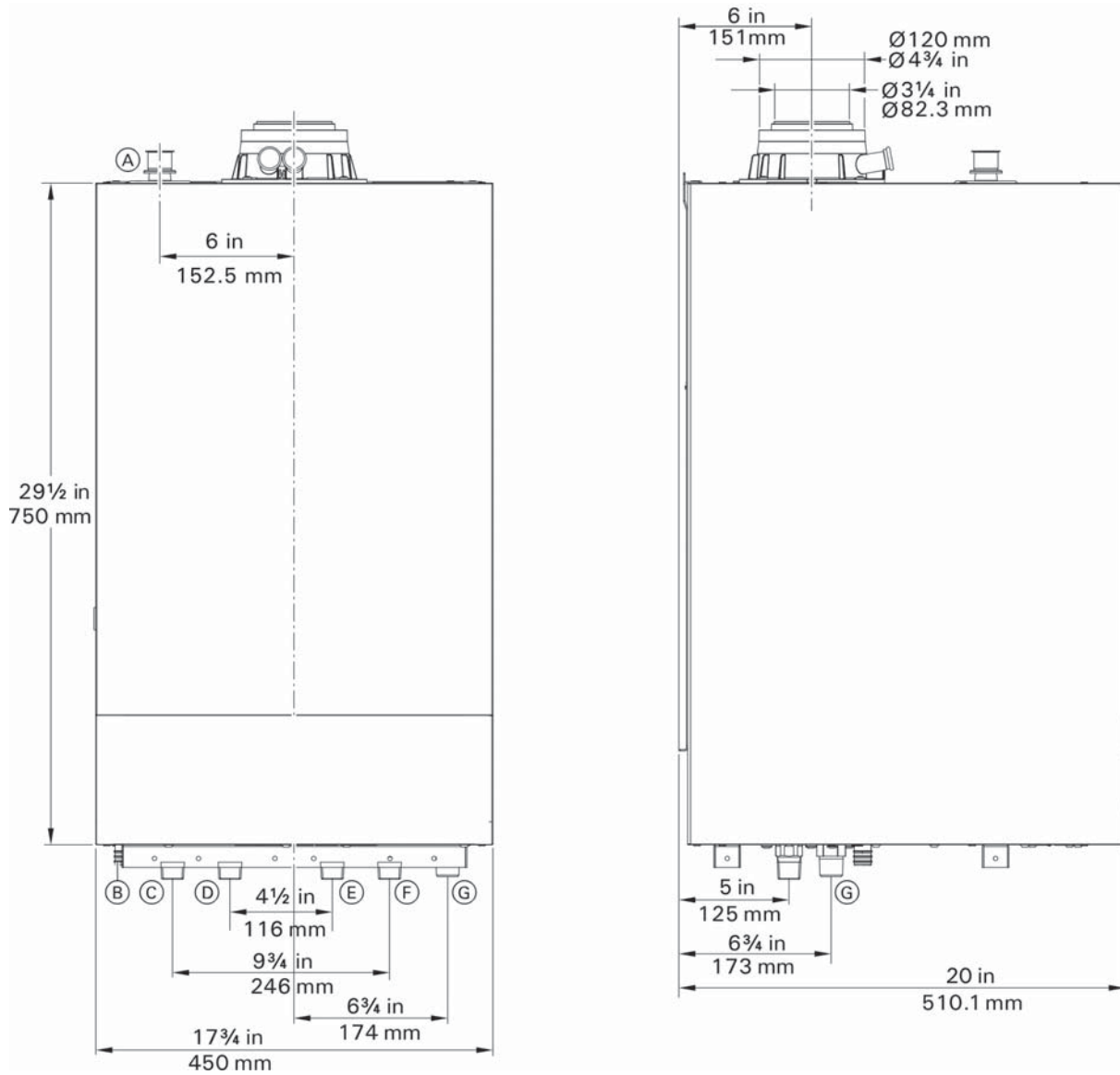

Front view

Side view

Legend

- Ⓐ Safety valve, pressure gauge connection
- Ⓑ Condensate drain
- Ⓒ Heating system supply
- Ⓓ For B1HE series, DHW tank heating supply
For B1KE series, DHW
- Ⓔ For B1HE series, DHW tank heating return
For B1KE series, DCW
- Ⓕ Heating system return
- Ⓖ Fuel gas connection

Boiler Dimensions 150/199

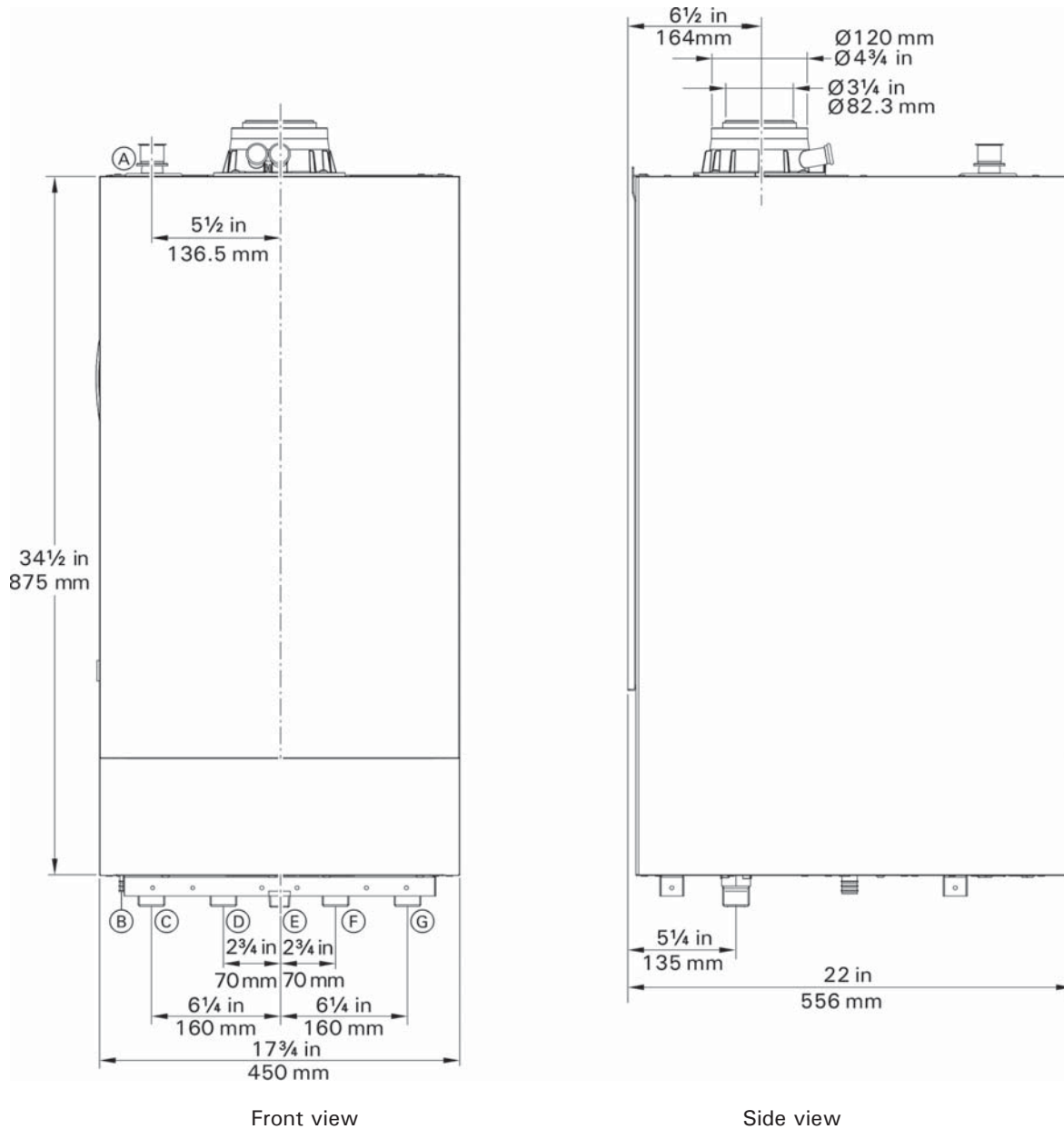

Boiler Dimensions With Piping Connections

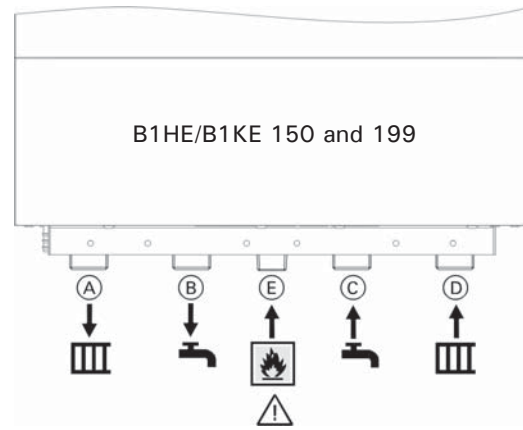
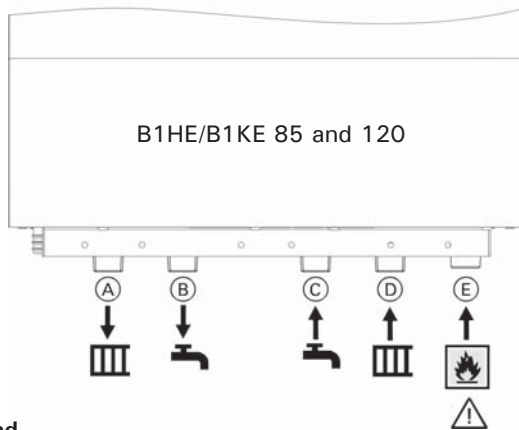

Legend

- Ⓐ Heating system supply
B1HE/B1KE 85, 120 3/4 in. NPT
B1HE/B1KE 150, 199 1 in. NPT
- Ⓑ Tank heating supply (B1HE)/DHW (B1KE)
B1HE/B1KE 85, 120 3/4 in. NPT
B1HE/B1KE 150, 199 1 in. NPT
- Ⓒ Tank heating return (B1HE)/DCW (B1KE)
B1HE/B1KE 85, 120 3/4 in. NPT
B1HE/B1KE 150, 199 1 in. NPT

- Ⓓ Heating system return
B1HE/B1KE 85, 120 3/4 in. NPT
B1HE/B1KE 150, 199 1 in. NPT
- Ⓔ Gas connection NPT 3/4" (male thread)

Boiler Minimum Clearances

Recommended minimum boiler service clearances

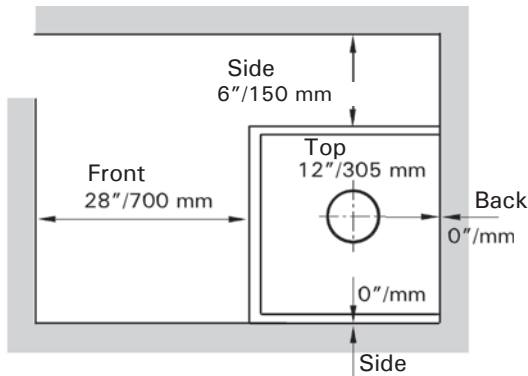

Recommended minimum boiler clearances to combustibles

Note:The Vitodens 100-W boiler has passed the zero inches vent clearance to combustibles testing requirements dictated by the boiler Harmonized Standard ANSI Z21.13. CSA 4.9 (latest edition) and therefore is listed for zero clearance to combustibles when vented with a single-wall special venting system (AL-29-4C material) or UL/ULC-listed CPVC gas vent material. The zero inches vent clearance to combustibles for the Vitodens 100-W boiler supercedes the clearance to combustibles listing that appears on the special venting system label.

Top clearance - 12" (30 cm).

Clearance to combustibles

Top	Front	Rear	Left	Right	Vent pipe *1
0	0 AL, CL	0	0	0	0

*1 Refer to the Installation Instructions of the Vitodens Venting System for details.



See the Vitodens Venting System Installation Instructions.

AL = Alcove
CL = Closet

Heating Circuit Pumps

Waterside Flow (boiler circuit)

The Vitodens 100-W is designed only for closed loop, forced circulation hot water heating systems.

A low-loss header must be used when the system flow rate exceeds the maximum (or minimum) flow rate of the Vitodens 100-W boiler. An alternative method may be used, such as primary secondary piping using closely spaced tees.

A low-loss header offers additional benefits not provided by a pair of closely spaced tees. Viessmann strongly recommends and prefers the use of a low-loss header over closely spaced tees. Please see page 16 for details.

Use standard friction loss method for pipe sizing. Observe boiler maximum and minimum flow rate limitations. If system flow rate exceeds boiler maximum flow rate (as stated on page 16) or if system flow rate is unknown, Viessmann strongly recommends the installation of a low-loss header. See page 16 for low-loss header information or refer to the Vitodens Venting System Installation Instructions.

Heating circuit pumps

The Vitodens 100-W B1HE/B1KE comes with a built-in boiler pump.

All other pumps are field supplied and should be sized based on pressure drop.

IMPORTANT

Pump selection must be based on accurate system flow and pressure drop calculations (including DHW sizing).

Adjusting Pump Rate of Integral Circulation Pump

Residual Head B1HE/KE 85-120

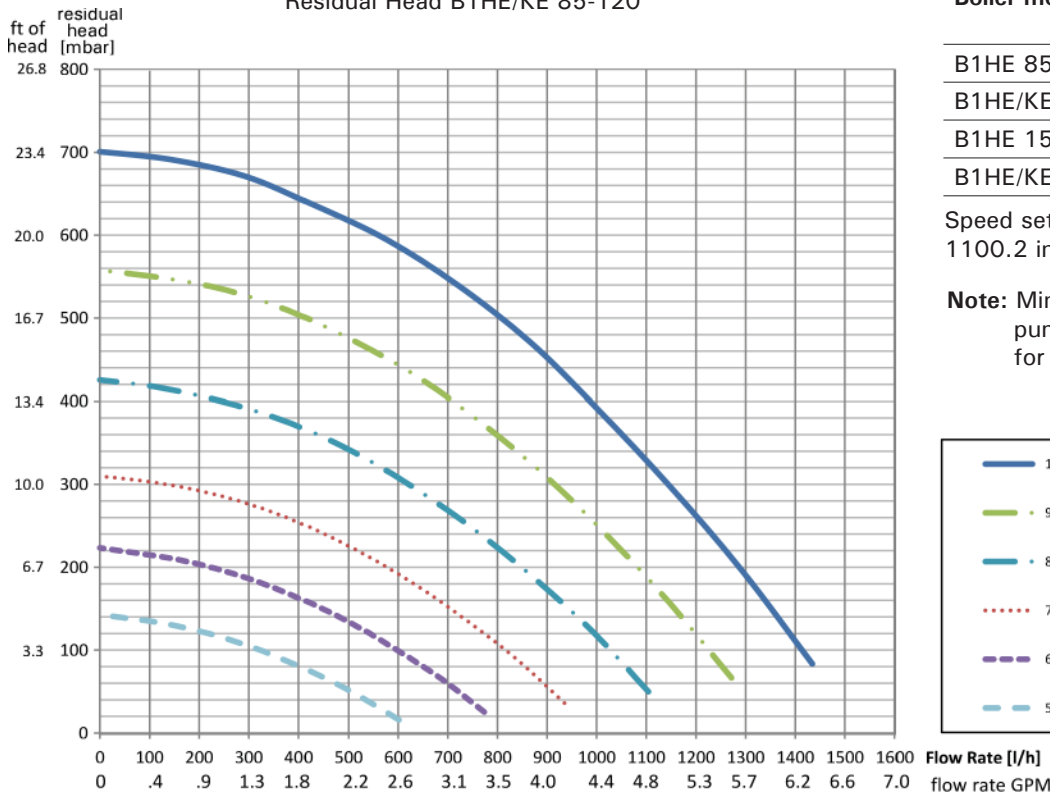

Boiler model	Factory-set speed settings in %
B1HE 85	80
B1HE/KE 120	100
B1HE 150	70
B1HE/KE 199	85

Speed setting (%): Parameter 1100.2 in the Boiler group

Note: Minimum adjustment of boiler pump speed setting is 50% for all models.

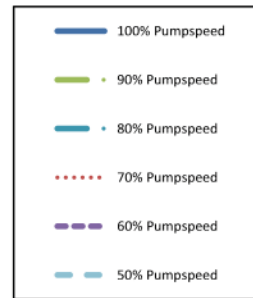

Residual Head B1HE/KE 150-199

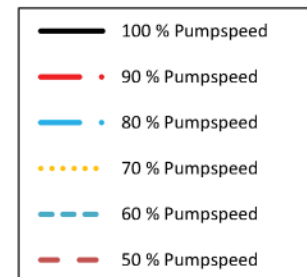
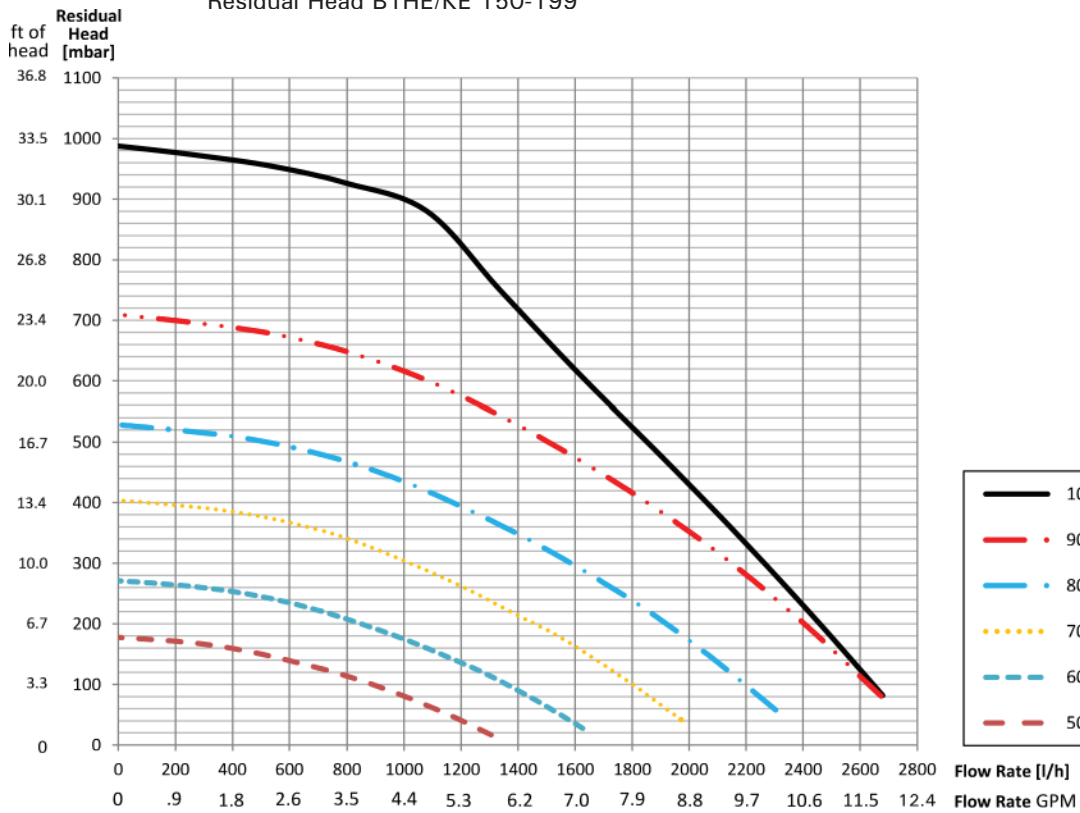

Heating Circuit Pumps *(continued)*

DHW Production Planning

With the B1KE for instantaneous DHW heating or the B1HE DHW connections for DHW production via a stand-alone DHW storage tank, the Vitodens 100-W boilers series offers the right solution for every need.

Various factors must be taken into account when designing the DHW system and when deciding between the instantaneous DHW production with the B1KE and DHW production via a stand-alone DHW storage tank with the B1HE.

Domestic Hot Water Production via DHW Storage Tank

Vitodens 100-W B1HE series boilers can be used in conjunction with the stand-alone DHW storage tanks offered by Viessmann.

Size and select the DHW storage tank based on the forecast DHW consumption of the building in question.

For further technical information on DHW storage tanks, see the Vitocell Technical Data Manual.

Such factors are:

- DHW requirement, level of comfort and convenience
- Number of draw points
- Distance of draw points from the boiler/DHW storage tank
- System retrofit
- Space requirements

Domestic Hot Water Production via Instantaneous DHW Plate Heat Exchanger (B1KE)

The B1KE is equipped with an electronically controlled instantaneous DHW plate heat exchanger.

The comfort control function (if selected) ensures that the instantaneous DHW plate heat exchanger is kept warm.

This translates into immediate availability of domestic hot water at any required temperature level.

Options

		B1HE	B1KE
DHW requirement, level of comfort and convenience	DHW requirement for an apartment	+	+
	DHW requirement for a single-family house	+	0
	Central DHW requirement for a multi-family house	+	-
	Decentralized DHW requirement for a multi-family house	+	+
Number of draw points	One draw point	0	+
	Several draw points, non-simultaneous use	0	+
	Several draw points, simultaneous use	+	-
Distance of draw points from the boiler/ DHW storage tank	Up to 23 ft. (7 m) (without DHW recirculation line)	-	+
	With DHW recirculation line	+	-
System retrofit	DHW storage tank already installed	+	-
	Replacement of existing Combi boiler	-	+
Space requirements	Minimal space available (installation in alcove)	0	+
	Adequate space available (boiler room)	+	+

+ (recommended)
 0 (recommended in certain cases)
 - (not recommended)

Removing the Front Panel

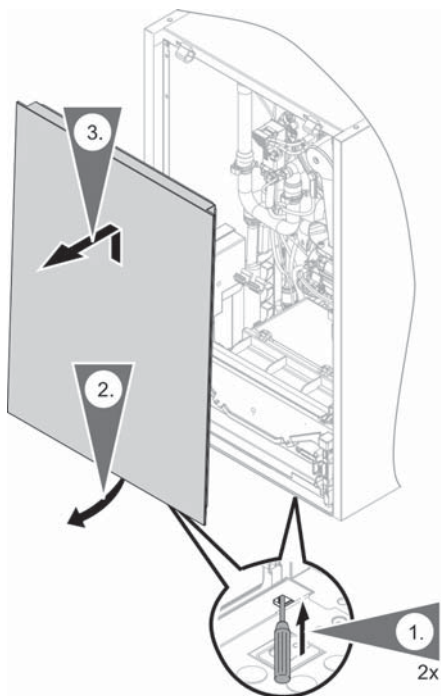

1. Using a screwdriver push up on the two retaining tabs.
2. Pull the lower edge of the boiler cover out.
3. Lift off the boiler cover.

Mounting

Mounting Vitodens 100-W boiler

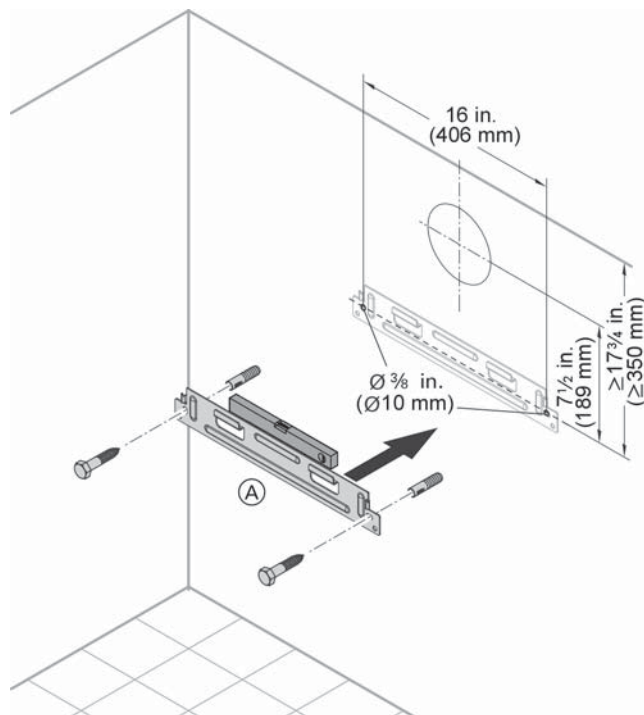

Legend

- Ⓐ Vitodens wall mounting bracket

Fitting the wall mounting bracket

Following are the installation instructions for the mounting bracket on each material. See the instructions applicable to your installation requirements.

Installing the wall mounting bracket

The Vitodens 100-W can be wall-mounted on a concrete wall.

Note: The enclosed screws and rawl plugs are only suitable for concrete. For other construction materials, use bolts and anchors that are suitable for 190 lb. (86 kg) loads.

Installation of mounting bracket on brick/concrete wall

1. Mark out the rawl plug holes.
2. Drill holes $\text{Ø } \frac{3}{8}$ in. ($\text{Ø } 10$ mm) and insert the rawl plugs supplied.
3. Fit the wall mounting bracket with the screws supplied.

Note: Check the condition of the wall where the boiler is to be installed. For the suitability of the supplied rawl plugs for various building materials, see the manufacturer's instructions. For other construction materials, use fixing materials with sufficient load bearing capacity.

CAUTION

Whichever mounting method is used, ensure that the bracket is tightly and securely fastened to wall. Failure to secure boiler properly could cause boiler to loosen, posing a severe safety hazard.

Hanging the Boiler

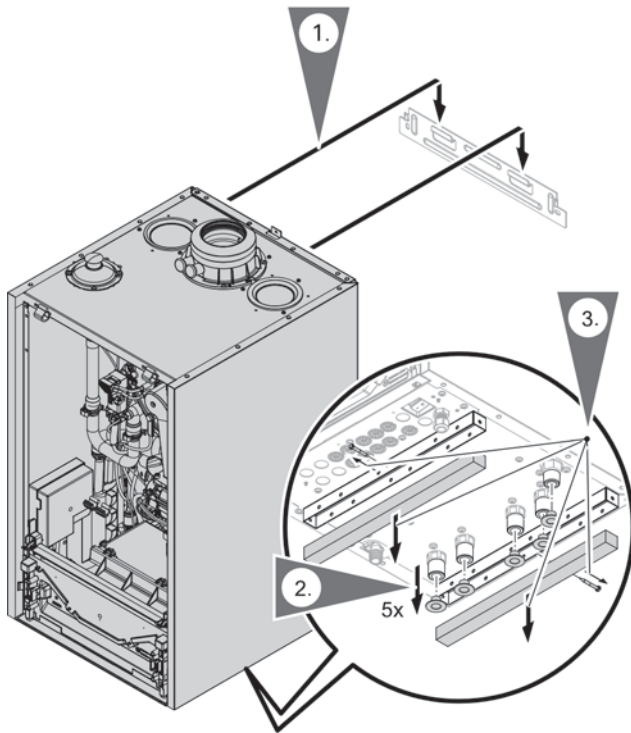

Note: Various installation components can be found in the installation fittings kit. Keep the installation components safe, as they will be required for later installation.

Note: To prevent dirt from entering the connections: Do not remove the protective caps until you are about to fit the boiler.

1. Mount the boiler on the wall mounting bracket. Ensure that all four mounting tabs of the wall mounting bracket have locked into the boiler.
2. Remove plastic shipping caps from the boiler connections.
3. Remove the wooden blocks from the bottom rails of the boiler.

Condensate

Condensate Connection

Install the condensate drain pipe Ø ¾ in. (Ø 19 mm) with a suitable gradient (min. 2.5%).

Discharge condensate from the boiler into the drainage system, either directly or (if required) via a neutralization unit (accessory).

Condensate connection for Vitodens 100-W

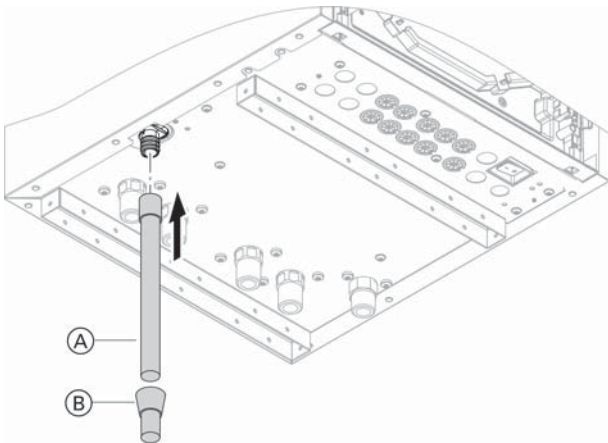

Legend

- Ⓐ Flexible discharge tubing
- Ⓑ Discharge tubing

The condensate drain of the Vitodens 100-W boiler is equipped with a built-in siphon trap in order to keep flue gases from being discharged via the condensate drain.

IMPORTANT

Pipe ventilation must take place between the siphon trap and the neutralization unit (if applicable).

Condensate Drainage and Condensate Neutralization

The condensate formed both in the condensing boiler and in the flue gas pipe must be discharged into the public sewage system in accordance with all applicable local regulations. The condensate produced by a gas-fired heating system has a pH value between 3 and 4.

Some local codes may require the use of a separate neutralization unit to treat the aggressive and corrosive condensate. With a neutralization unit installed, all condensate from the boiler and the flue gas pipe enters into the neutralization unit where it is treated and released into the public sewage system with a safe pH value of above 6.5.

The use of neutralization granulate (performing the neutralizing process) is dependent on the operation of the heating system. To determine the required refill amount, check granulate level several times during the first year of operation. In some cases one granulate fill may last an entire year.

Contact Viessmann to order a neutralization unit for the Vitodens 100-W boiler.

See Viessmann Price List for order information.

The condensate discharge outlet to the drainage system connection must be clearly visible. It must be installed with a suitable gradient and provided with a stench trap.

If the condensate outlet of the Vitodens 100-W boiler is lower than the drain, a condensate pump must be used.

Only corrosion-resistant materials may be used for condensate drainage purposes (e.g. braided hose). Do not use galvanized materials or materials containing copper for piping, couplings etc. The condensate drain must have a trap.

Please note that other requirements may apply depending on local regulations and/or project-specific details.

It is advisable to contact your local waterworks office (authority responsible for waste water regulations) well before commencing with the installation of the neutralization unit in order to establish details of local regulations that apply.

The following table shows the concentration of (effluent) substances (e.g. heavy metals) contained in the waste water from the Vitodens 100-W condensing boiler.

Condensate (effluent) substances	Values measured in mg/L
Lead	< 0.01
Cadmium	< 0.005
Chromium	< 0.01
Copper	< 0.01
Nickel	< 0.01
Zinc	< 0.05
Tin	< 0.05

Electrical Connections

Electrical Connection

All electrical connections are made to the boiler's integrated boiler control unit (120VAC, 1 phase, 60 Hz, 12 amps). Use disconnect means and power service switch as per local code requirements.

Boiler temperature sensor

The boiler temperature sensor is connected to the control unit and built into the boiler.

Frost protection

Frost protection is continuously active. The burner is switched ON when the boiler water temperature reaches 41°F (5°C) and is switched OFF again when the boiler water temperature reaches at least 59°F (15°C) [but not more than 68°F (20°C)].



For details on the control, refer to the Vitodens 100-W Operating Instructions.

Control Unit

Function and construction:

The control is integrated into the Vitodens 100-W boiler.

- Integrated diagnostic system
- For room temperature-dependent operation, an external control or a room temperature thermostat may be connected
- To control DHW temperature
- External heat demand
- Viessmann outdoor temperature sensor (OTS) (field wiring)
- Instantaneous DHW control (B1KE)

The control unit consists of:

- LCD Display
- Push button operation and setting of boiler water temperature
- Temperature adjustable high limit
- Boiler temperature sensor
- Burner fault display
- Burner fault reset
- Pressure gauge
- Fuse
- Integrated WiFi

Accessories

Neutralization Unit for Single-Boiler Applications

with neutralizing granulate

for models 85, 120

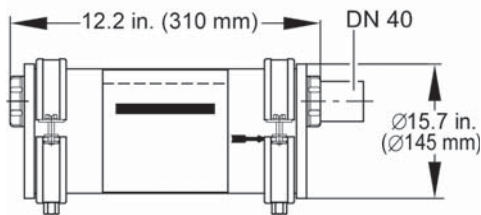

for models 150, 199

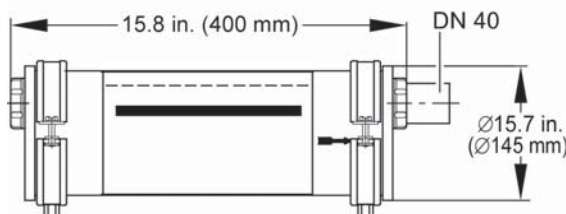

Neutralization Pellets

2 x 1.3 kg for refill or replacement purposes

Fuel Conversion Label Kit (NG > LPG)

(included in boiler technical literature set)

The Vitodens 100-W, boiler comes factory set for operation with natural gas. All Vitodens 100-W models can be field converted to operate with liquid propane gas (as well as back to natural gas as required). The kit includes instructions and labels for field conversion.

Low-Loss Header

When used in conjunction with the Vitodens 100-W boiler, the low loss header acts as hydraulic break, decoupling boiler and system circuits from each other.

It is recommended to use the low-loss header in applications in which the total system flow rate exceeds the max. (or minimum) boiler flow rate.

For maximum boiler flow rates, starting on page 11 of this manual.

Viessmann strongly recommends the use of a low-loss header in cases where the system head and flow rates are unknown.

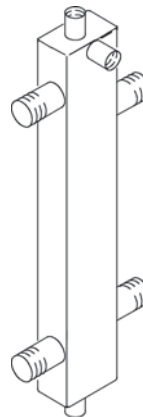

The low-loss header helps eliminate air and debris [D] from the heating system.

See illustrations for design and principle of operation on page 17.

The low-loss header is available in various sizes (see page 17). Select the size based on the maximum system flow rate of your application.

Accessories *(continued)*

Low-loss header design (Typical)

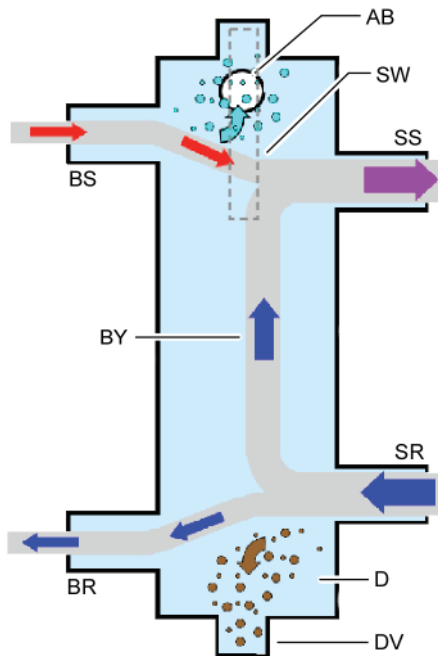

Legend

- AB Air Bleed
- BR Boiler Return
- BS Boiler Supply
- BY Bypass (with laminar flow)
- D Debris
- DV Drain Valve
- SR System Return
- SS System Supply
- SW Sensor Well

IMPORTANT

When installing a low-loss header, the system mixed supply temperature (T3) must be calculated as follows:

$$T3 = \frac{T1 \times V_{primary} + T4 \times V_{bypass}}{V_{secondary}}$$

Principle of Operation

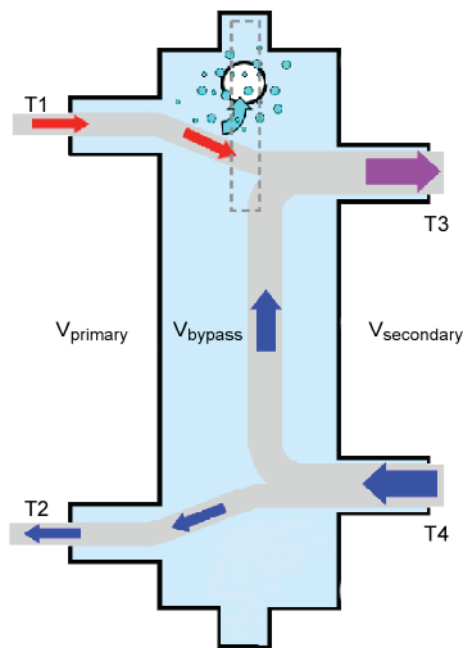

Legend

- T1 Boiler supply temperature
- T2 Boiler return temperature
- T3 System supply temperature
- T4 System return temperature
- Vprimary Boiler circuit flow rate
- Vsecondary Heating circuit flow rate
- Vbypass Bypass flow rate
- Qprimary Heat supplied by boiler
- Qsecondary Heat consumed by system

$V_{primary} < V_{secondary}$

$T1 > T3$

$T2 = T4$

$Q_{primary} = Q_{secondary}$

$T1 \ 167^{\circ}F \ (75^{\circ}C)$

$V_{secondary} = V_{primary} + V_{bypass}$

Model No.	Max. system flow rate
Type 80/60	19.5 GPM (4.4 m ³ /h)
Type 120/80	35.2 GPM (8 m ³ /h)

Accessories *(continued)*

Outdoor Temperature Sensor (OTS)

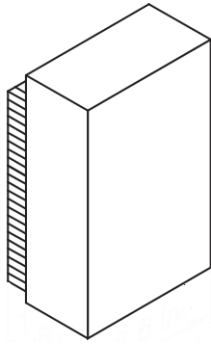

Sensor location:

- North or northwest wall of building
- 80 to 100 in. (2 to 2.5 m) above ground or in case of a multi-storey building approximately halfway up the second floor

Electrical connection:

- 2-wire cable, max. cable length 115 ft. (35 m) with a wire size of min. AWG 16 copper
- Cable to the outdoor sensor must not be laid near line voltage wiring (120VAC or greater)

Max. ambient temperature during transport, storage and operation:

-40 to 194°F (-40 to 90°C)

Viessmann NTC 10 kΩ

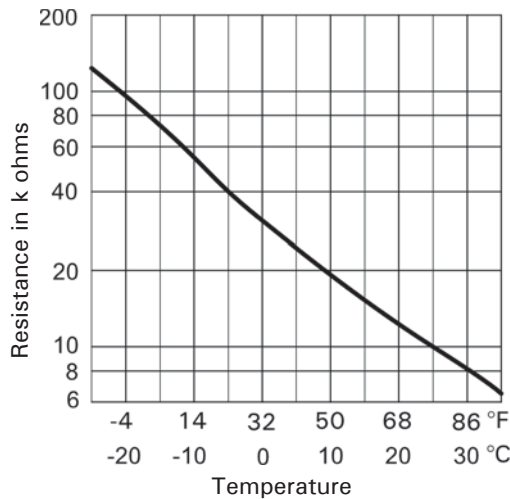

DHW Tank Temperature Sensor (B1HE)
(immersion temperature sensor)

Supplied with:

- Cable length approx. 12 ft. (3.75 m), ready to plug in
- All pipe connections are field supplied.

Specification

Max. ambient temp.

- at operation: 32 to 194°F (0 to 90°C)
- when storing or transporting: - 4 to + 158°F (-20 to + 70°C)
- Sensor type: Viessmann NTC
10K ohms @ 77°F (25°C)

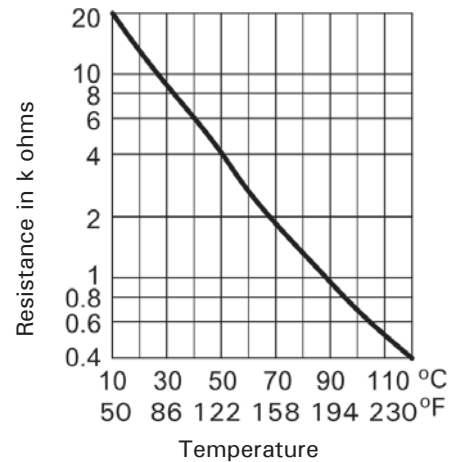

Standard Equipment

Standard Equipment

The Vitodens 100-W gas-fired condensing boiler with Inox-Radial heat exchanger surfaces, modulating stainless steel MatrixPlus cylinder gas burner c/w:

- installation fittings with 30 psig pressure relief valve, air vent and pressure gauge
- two fill/drain valves
- all mounting hardware
- Outdoor temperature sensor (OTS)
- temperature gauge
- DHW pressure relief valve (B1KE)
- DHW tank sensor (B1HE)

The boiler comes fully piped and pre-wired.

Wall mounting componentry

The following wall mounting components are supplied with the Vitodens 100-W boiler:

- Mounting bracket
- Mounting bolts
- Installation fittings
- Screws for mounting bracket on
 - wood studs (2 in. x 4 in.)
 - metal studs
 - brick/concrete wall

How the Vitodens 100-W boiler operates...

The Vitodens 100-W boiler uses a premix combustion system, which is designed to deliver a precise air-gas mixture to the burner for complete combustion. The gas is injected upstream of the blower. The burner and heat exchanger are part of a forced-draft design. The benefits of forced-draft systems are lower component temperatures, direct air-fuel connection (premix) for improved mixing, and longer service life of the boiler due to mild to moderate ambient conditions.

The MatrixPlus cylinder burner, blower and the combination gas valve are factory calibrated and pre-adjusted.

Blower speed is automatically increased or decreased based on heat demand [thereby regulating the amount of combustion air drawn.

Installation Examples

IMPORTANT

The examples on the following pages depict possible piping layouts of the Vitodens 100-W boiler.

Please note that the following examples are simplified conceptual drawings only!

Piping and necessary componentry must be field verified. A low water cut-off (LWCO) must be installed where required by local codes. Proper installation and functionality in the field is the responsibility of the heating contractor.

System Layout 1

Vitodens 100-W, B1HE 85, 120, 150, 199 with

- DHW storage tank
- one heating circuit connected directly to the boiler

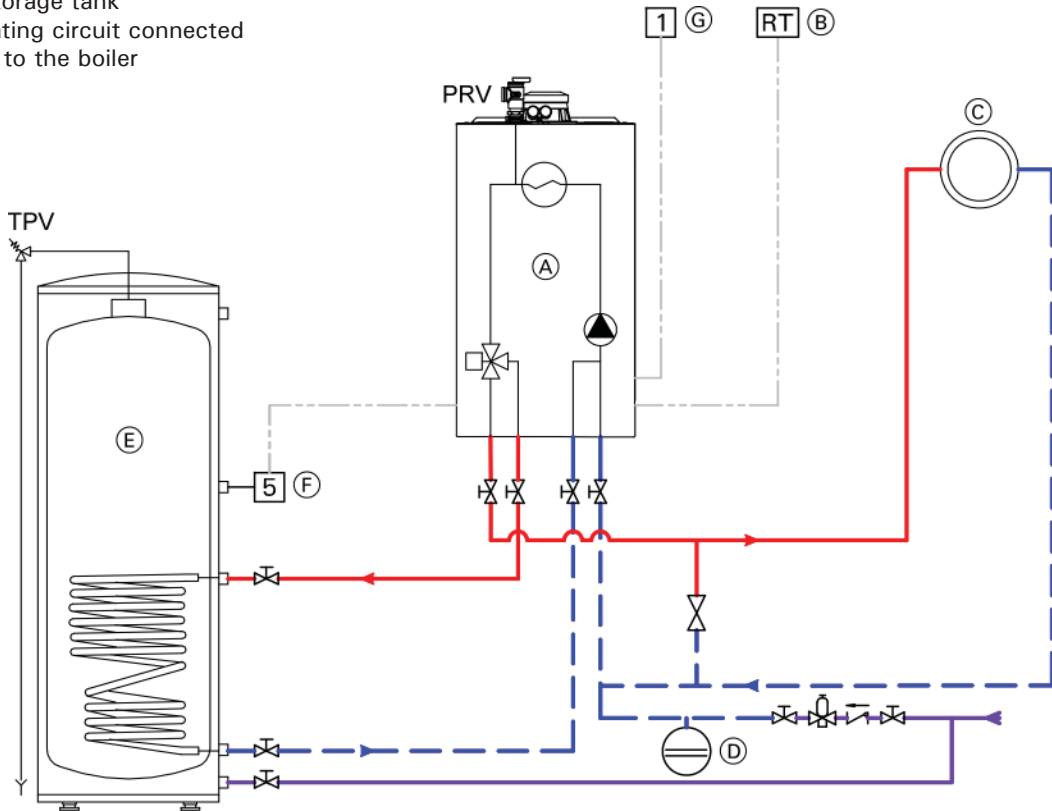

Legend

- PRV Pressure relief valve
- TPV Temperature and pressure relief valve
- (A) Vitodens 100-W gas fired condensing boiler
- (B) External boiler controller with room temperature connection (field supplied)
- (C) Heating circuit
- (D) Expansion tank
- (E) DHW storage tank
- (F) DHW tank temperature sensor (or DHW temperature switch)
- (G) Outdoor temperature sensor

Note: Refer to the residual head curves on page 11. The use of a low-loss header is recommended if the water flow rate is above or below the operating range. The low-loss header is available as accessory part.

IMPORTANT

Ensure that a pressure activated by-pass is installed if there are system component(s) in (C) that may isolate the flow to the pump.

Maximum Flow Rates

Model B1HE		85	120	150	199
Output	MBH	80	113	141	187
Δt					
30°F (17°C) rise	GPM (L/h)	5.3 (1204)*	7.5 (1703)*	9.4 (2135)*	12.5 (2839)*
35°F (19.5°C) rise	GPM (L/h)	4.6 (1045)	6.5 (1476)*	8.1 (1840)	10.7 (2430)*
40°F (22°C) rise	GPM (L/h)	4.0 (908)	5.7 (1295)	7.1 (1613)	9.4 (2135)

* Requires low loss header or closely spaced tees.

System Layout 2

Vitodens 100-W, B1HE 85, 120, 150, 199 with...

- DHW storage tank
- low-loss header
- one heating circuit

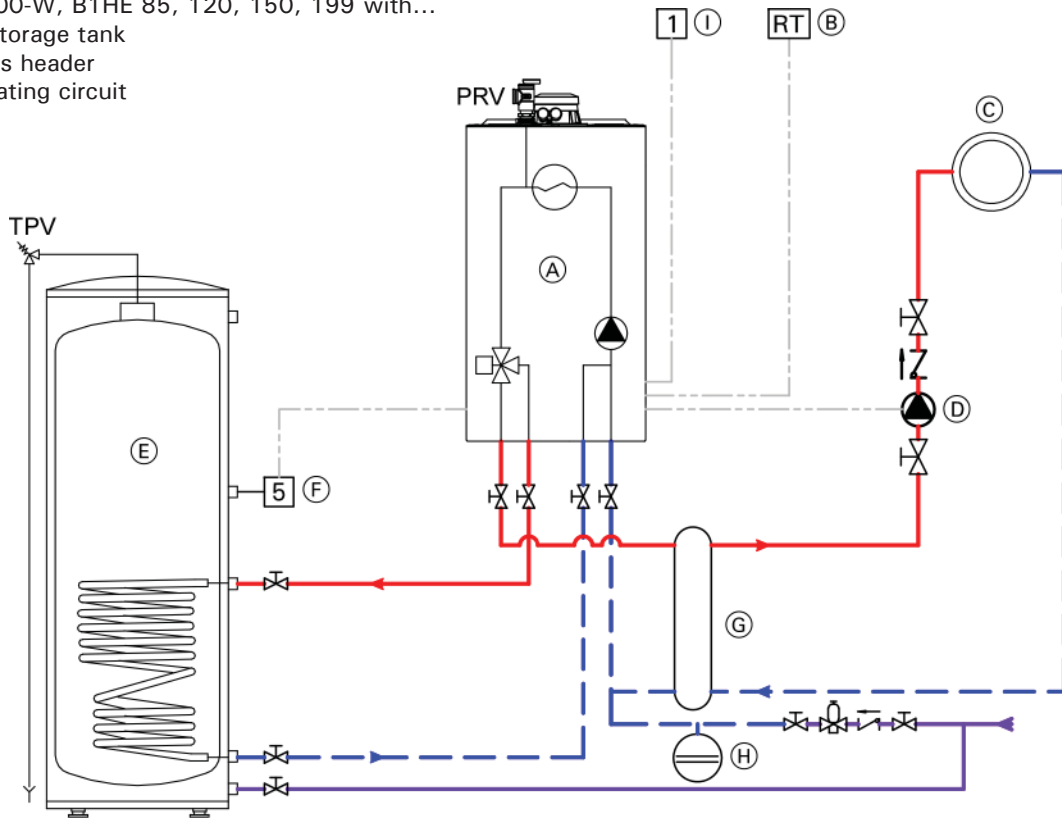

Legend

- PRV Pressure relief valve
- TPV Temperature and pressure relief valve
- (A) Vitodens 100-W gas-fired condensing boiler
- (B) External boiler controller with room thermostat connection (field supplied)
- (C) Heating circuit
- (D) Heating circuit pump P2
- (E) DHW storage tank
- (F) DHW tank temperature sensor (or DHW temperature switch)
- (G) Low-loss header
- (H) Expansion tank
- (I) Outdoor temperature sensor

Note: Refer to the residual head curves on page 11.
 The use of a low-loss header is recommended if the water flow rate is above or below the operating range.
 The low-loss header is available as accessory part.

IMPORTANT

DHW supply and return piping between boiler DHW connections and the Viessmann DHW tank connections, shall be a minimum of 1¼ in. nominal pipe diameter.

This ensures that the head of the pump is fully utilized to overcome the resistance of the DHW heat exchanger coil and to provide sufficient water flow to the boiler heat exchanger.

In non-Viessmann DHW tank applications, perform, in addition to the above, accurate calculations for DHW tank coil pressure drop versus boiler pump head to ensure sufficient water flow to the boiler heat exchanger.

Failure to heed the above instructions may cause boiler short-cycling and inadequate DHW supply.

Maximum Flow Rates

Model B1HE		85	120	150	199
Output	MBH	80	113	141	187
Δ t					
30°F (17°C) rise	GPM (L/h)	5.3 (1204)*	7.5 (1703)*	9.4 (2135)*	12.5 (2839)*
35°F (19.5°C) rise	GPM (L/h)	4.6 (1045)	6.5 (1476)*	8.1 (1840)	10.7 (2430)*
40°F (22°C) rise	GPM (L/h)	4.0 (908)	5.7 (1295)	7.1 (1613)	9.4 (2135)

* Requires low loss header or closely spaced tees.

System Layout 3

Vitodens 100-W, B1HE 85, 120, 150, 199 with

- DHW storage tank
- closely spaced tees
- one heating circuit

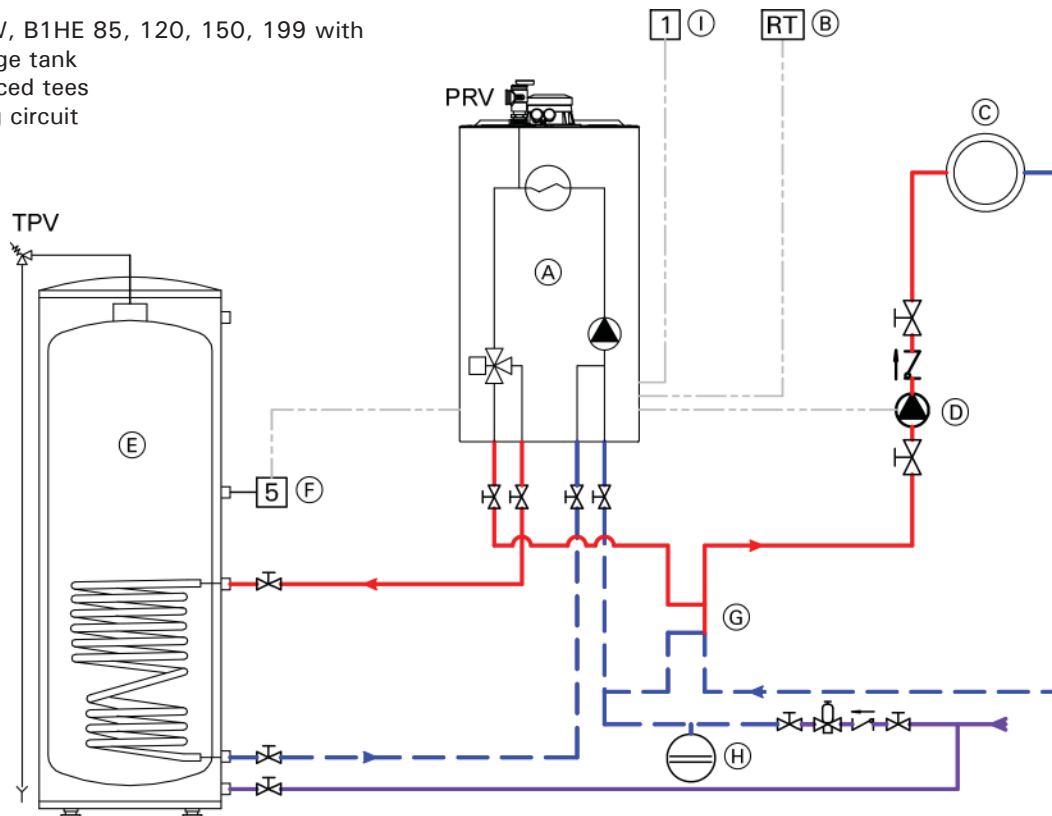

Legend

- PRV Pressure relief valve
- TPV Temperature and pressure relief valve
- (A) Vitodens 100-W gas-fired condensing boiler
- (B) External boiler controller with room thermostat connection (field supplied)
- (C) Heating circuit
- (D) Heating circuit pump P2
- (E) DHW storage tank
- (F) DHW tank temperature sensor (or DHW temperature switch)
- (G) Closely spaced tees, 4x pipe Ø or 12 in. (305 mm) * 1
- (H) Expansion tank
- (I) Outdoor temperature sensor

* 1 A low-loss header offers additional benefits not provided by a pair of closely spaced tees. Viessmann strongly recommends and prefers the use of a low-loss header over closely spaced tees.

Note: Refer to the residual head curves on page 11.

The use of a low-loss header is recommended if the water flow rate is above or below the operating range. The low-loss header is available as accessory part.

IMPORTANT

DHW supply and return piping between boiler DHW connections and the Viessmann DHW tank connections, shall be a minimum of 1¼ in. nominal pipe diameter.

This ensures that the head of the pump is fully utilized to overcome the resistance of the DHW heat exchanger coil and to provide sufficient water flow to the boiler heat exchanger.

In non-Viessmann DHW tank applications, perform, in addition to the above, accurate calculations for DHW tank coil pressure drop versus boiler pump head to ensure sufficient water flow to the boiler heat exchanger.

Failure to heed the above instructions may cause boiler short-cycling and inadequate DHW supply.

Maximum Flow Rates

Model B1HE		85	120	150	199
Output	MBH	80	113	141	187
Δ t					
30°F (17°C) rise	GPM (L/h)	5.3 (1204) *	7.5 (1703) *	9.4 (2135) *	12.5 (2839) *
35°F (19.5°C) rise	GPM (L/h)	4.6 (1045)	6.5 (1476) *	8.1 (1840)	10.7 (2430) *
40°F (22°C) rise	GPM (L/h)	4.0 (908)	5.7 (1295)	7.1 (1613)	9.4 (2135)

* Requires low loss header or closely spaced tees.

System Layout 4

Vitodens 100-W, B1KE 120, 199 with

- one heating circuit connected directly to the boiler

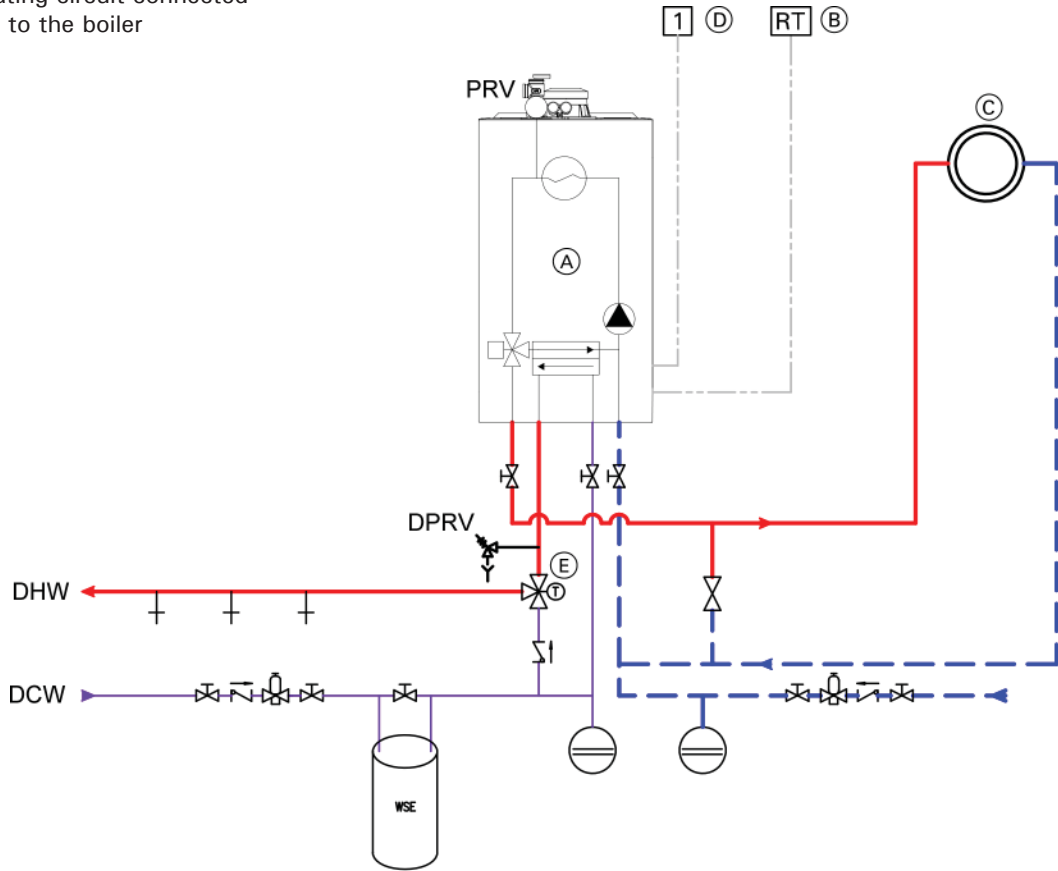

Legend

- PRV Pressure relief valve (boiler)
- DPRV Pressure relief valve (DHW 150 psi)
- WSE Water softener equipment
- DHW Domestic hot water
- DCW Domestic cold water
- (A) Vitodens 100-W gas-fired condensing boiler
- (B) External boiler controller with room thermostat connection (field supplied)
- (C) Heating circuit
- (D) Outdoor temperature sensor
- (E) DHW tempering valve (field supplied)

Note: Refer to the residual head curves on page 11.
 The use of a low-loss header is recommended if the water flow rate is above or below the operating range.
 The low-loss header is available as accessory part.

Maximum Flow Rates

Model B1KE		120	199
Output	MBH	113	187
Δt			
30°F (17°C) rise	GPM (L/h)	7.5 (1703)*	12.5 (2839)*
35°F (19.5°C) rise	GPM (L/h)	6.5 (1476)*	10.7 (2430)*
40°F (22°C) rise	GPM (L/h)	5.7 (1295)	9.4 (2135)

* Requires low loss header or closely spaced tees.

System Layout 5

Vitodens 100-W, B1KE 120, 199 with...

- low-loss header
- one heating circuit

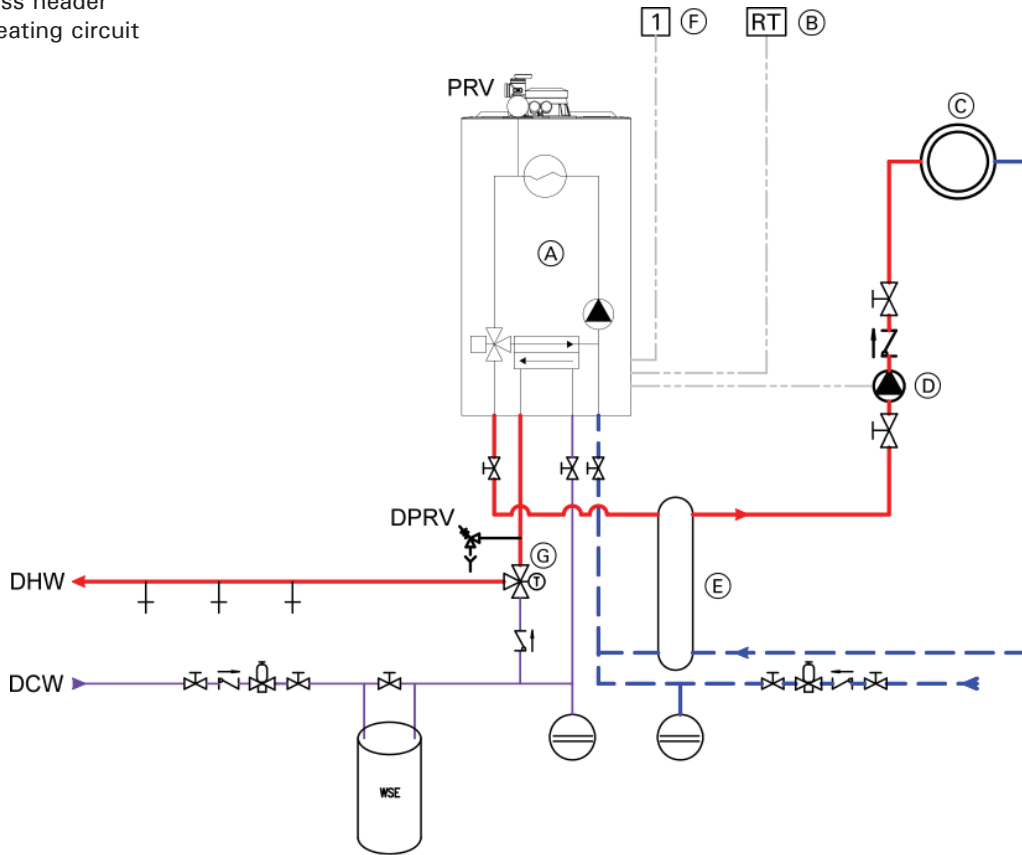

Legend

- PRV Pressure relief valve (boiler)
- DPRV Pressure relief valve (DHW 150 psi)
- WSE Water softener equipment
- DHW Domestic hot water
- DCW Domestic cold water
- (A) Vitodens 100-W gas-fired condensing boiler
- (B) External boiler controller with room thermostat connection (field supplied)
- (C) Heating circuit
- (D) Heating circuit pump [P2]
- (E) Low-loss header (there is no LLH temperature sensor available for the B1KE)
- (F) Outdoor temperature sensor
- (G) DHW tempering valve (field supplied)

Note: Refer to the residual head curves on page 11.
The use of a low-loss header is recommended if the water flow rate is above or below the operating range.
The low-loss header is available as accessory part.

Maximum Flow Rates

Model B1KE		120	199
Output	MBH	113	187
Δt			
30°F (17°C) rise	GPM (L/h)	7.5 (1703)*	12.5 (2839)*
35°F (19.5°C) rise	GPM (L/h)	6.5 (1476)*	10.7 (2430)*
40°F (22°C) rise	GPM (L/h)	5.7 (1295)	9.4 (2135)

* Requires low loss header or closely spaced tees.

System Layout 6

Vitodens 100-W, B1KE 120, 199

- closely spaced tees
- one heating

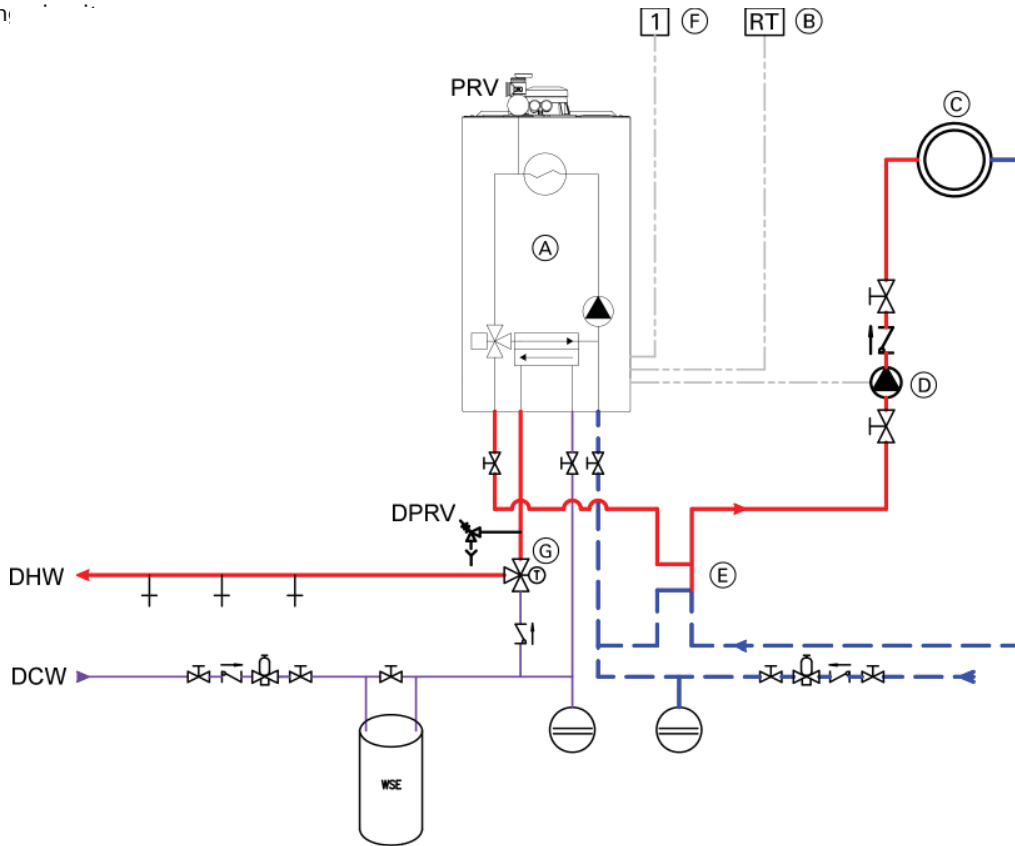

Legend

- PRV Pressure relief valve (boiler)
- DPRV Pressure relief valve (DHW 150 psi)
- WSE Water softener equipment
- DHW Domestic hot water
- DCW Domestic cold water
- (A) Vitodens 100-W gas-fired condensing boiler
- (B) External system controller with room thermostat connection (field supplied)
- (C) Heating circuit
- (D) Heating circuit pump [P2]
- (E) Closely spaced tees, 4x pipe Ø or 12 in. (305 mm)* 1
- (F) Outdoor temperature sensor (OTS)
- (G) DHW tempering valve (field supplied)

Note: Refer to the residual head curves on page 11.
The use of a low-loss header is recommended if the water flow rate is above or below the operating range.
The low-loss header is available as accessory part.

* 1 A low-loss header offers additional benefits not provided by a pair of closely spaced tees. Viessmann strongly recommends and prefers the use of a low-loss header over closely spaced tees.

Maximum Flow Rates

Model B1KE		120	199
Output	MBH	113	187
Δt			
30°F (17°C) rise	GPM (L/h)	7.5 (1703)*	12.5 (2839)*
35°F (19.5°C) rise	GPM (L/h)	6.5 (1476)*	10.7 (2430)*
40°F (22°C) rise	GPM (L/h)	5.7 (1295)	9.4 (2135)

* Requires low loss header or closely spaced tees.

System Design Considerations

IN THE COMMONWEALTH OF MASSACHUSETTS...

- this product shall be installed by a licensed plumber or gas fitter.
- the flexible connector (if used) may not exceed 36".
- any level type shutoff used must be of tee handle type.

Boiler location

As a direct vent appliance, the Vitodens 100-W may be installed for room air independent operation (sealed combustion direct vent) regardless of size and ventilation method of the room in which it is located.

The Vitodens 100-W may be installed, for example, in the main living area of a house, in non-ventilated utility rooms, cupboards, closets and alcoves with no clearance required from combustible materials, as well as in attics with a direct outlet for the flue gas/fresh air system. Follow all local and national codes.

Flue gas system

Viessmann coaxial PPS (Polypropylene - flame retardant) concentric flue gas/fresh air systems and two-pipe stainless steel/CPVC systems for room air independent operation (sealed combustion) and side wall venting are tested to ANSI Z21.13 - CSA 4.9 standards (latest edition) and are certified together with the Vitodens 100-W boiler as a constructional unit. The Vitodens 100-W boiler may also be vented vertically or horizontally, using a metallic AL29-4C® special stainless steel, or non-metallic CPVC single-wall, room air dependent venting system (UL/ULC listed for category IV).

For a more detailed description of the direct vent and single-wall vent system, please refer to the Vitodens Venting System Installation Instructions.

Flue gas temperature protection

Viessmann coaxial PPS (Polypropylene - flame retardant) flue pipes used for the Vitodens 100-W are rated for max. flue gas temperatures of up to 230°F (110°C).

Flue gas temperature protection is also included although the maximum permissible flue gas temperature will not be exceeded in any operating condition or in the event of malfunctioning.

Low water cut-off

The Vitodens 100 boiler is certified with an internal flow switch / sensor, however a low water cut-off may be required by local jurisdiction.

If required, an approved type low water cut-off device must be provided by the heating contractor. Do not install an isolation valve between the boiler and the low water cut-off.

System layout

- The max. boiler water temperature for ...
 - space heating is 180°F (82°C).
 - DHW production is 194°F (90°C).

To minimize distribution losses, Viessmann recommends that the heating and domestic hot water systems be based on a maximum boiler supply temperature of 158°F (70°C).

- Due to the low return temperatures required for gas condensing, avoid the use of mixing valves in the heating circuit whenever possible. If mixing valves are required, e.g. for multi-circuit systems or underfloor heating systems, only 3-way mixing valves may be used. Do not use 4-way mixing valves in a system with condensing boilers.

Water connections

Vitodens 100-W boilers can be used in any fully pumped hot water heating system.

Minimum system pressure is 12 psig (0.8 bar).

Chemical corrosion protection products

Corrosion does not typically occur in sealed heating systems which have been correctly installed and are correctly operated.

Many manufacturers of plastic pipes recommend the use of chemical additives. In this case, only commercially available corrosion protection products that have been approved for boilers with domestic hot water heating via single-wall heat exchangers (instantaneous plate heat exchangers or DHW tanks) may be used.

Underfloor heating systems

For underfloor heating systems Viessmann recommends the use of plastic tubing with an oxygen diffusion barrier in order to prevent the diffusion of oxygen through tubing.

If plastic tubing without an oxygen diffusion barrier is used in underfloor heating systems, Viessmann recommends that such systems be separated from the boiler with a heat exchanger.

Water Conditions for DHW B1KE

Media: pH value 6.5 to 12, glycol max. 30%

DHW (max. hardness): Chloride up to 250 mg/L

Hardness up to 358 ppm
(= max. 0.278 kg/m³ lime deposit)

System Design Considerations *(continued)*

Oxygen diffusion barrier underfloor tubing

The boiler warranty does not cover leaks resulting from corrosion caused by the use of underfloor plastic tubing without an oxygen diffusion barrier. Such systems must have the non-oxygen diffusion barrier tubing separated from the boiler with a heat exchanger.

Viessmann recommends the use of underfloor plastic tubing with an oxygen diffusion barrier.

Water quality

Treatment for boiler feed water should be considered in areas of known problems, such as where a high mineral content and hardness exist. In areas where freezing might occur, an antifreeze may be added to the system water to protect the system. Please adhere to the specifications given by the antifreeze manufacturer.

Do not use automotive silicate based antifreeze. Please observe that an antifreeze/water mixture may require a backflow preventer within the automatic water feed and influence components such as diaphragm expansion tanks, radiation, etc. Maximum antifreeze content is 50% for the B1HE 85, 120, 150, 199 and 30% for the B1KE 120 and 199. Do not use antifreeze other than specifically made for hot water heating systems.

The system may also contain components which might be negatively affected by antifreeze.

Check total system frequently when filled with antifreeze. Advise system operator/ultimate owner that system is filled with a glycol mix.

The heating contractor must provide a MSDS (Material Safety Data Sheet) for the antifreeze used to the system operator/ultimate owner.

Total output (MBH)	Total Hardness (ppm as CaCO ₃)
> 1 Total ≤ 680	≤ 200
> 680 to ≤ 2050	≤ 150
> 2050	≤ 2

The pH value of the heating water should be between 8.2 and 9.5

Warranty

Our warranty does not cover damages resulting from the following:

- installation or service by unqualified and unlicensed personnel.
- attempting to perform any repair work on the boiler other than that mentioned in the boiler literature.
- tampering with or attempting to readjust the factory settings of the combination gas valve
- leaks resulting from corrosion caused by the use of underfloor plastic tubing without an oxygen diffusion barrier.

For detailed warranty information, please read warranty sheet supplied with product.

B1HE Models 85 / 120 / 150 / 199

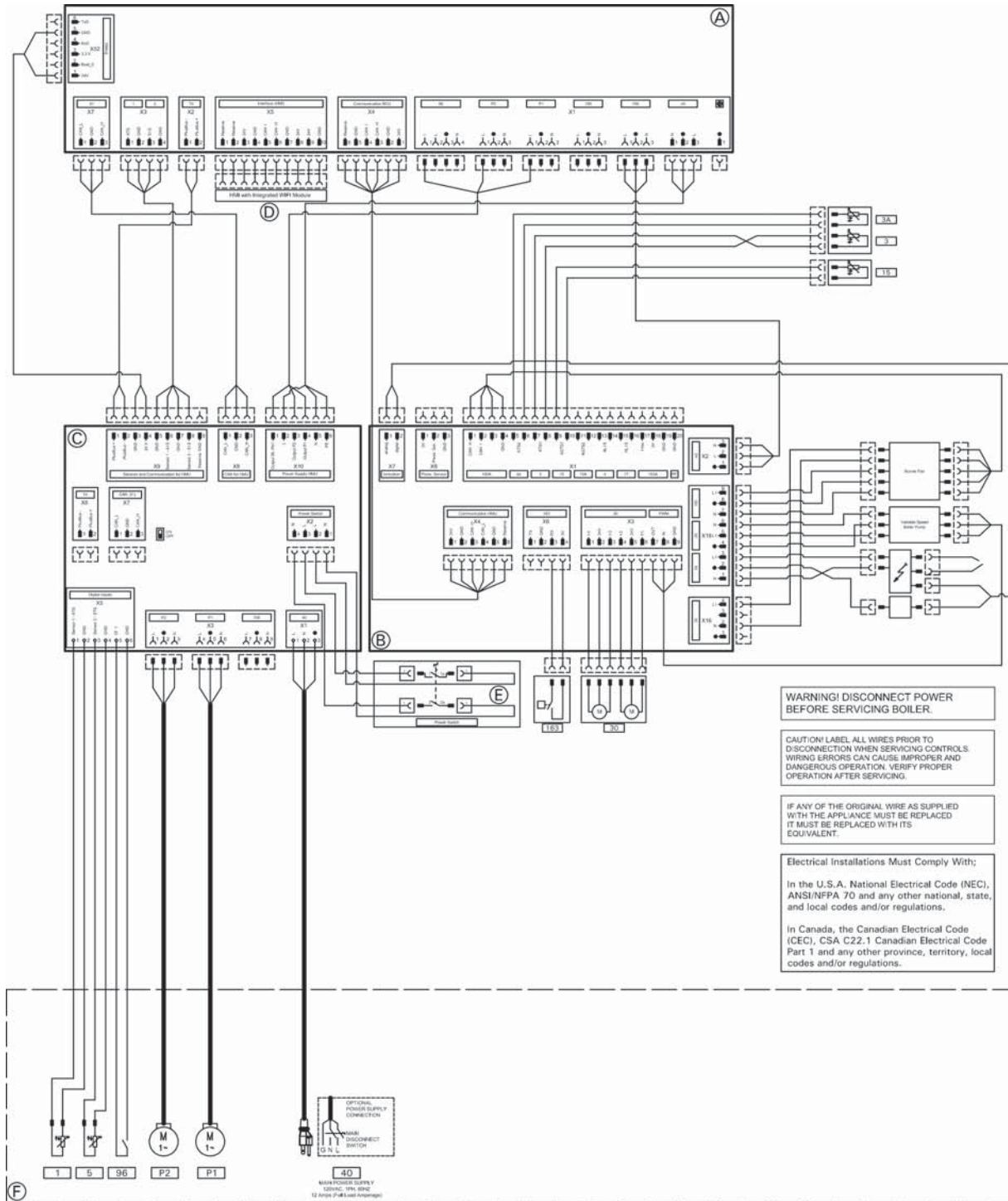

WARNING! DISCONNECT POWER BEFORE SERVICING BOILER.

CAUTION! LABEL ALL WIRES PRIOR TO DISCONNECTION WHEN SERVICING CONTROLS. WIRING ERRORS CAN CAUSE IMPROPER AND DANGEROUS OPERATION. VERIFY PROPER OPERATION AFTER SERVICING.

IF ANY OF THE ORIGINAL WIRE AS SUPPLIED WITH THE APPLIANCE MUST BE REPLACED IT MUST BE REPLACED WITH ITS EQUIVALENT.

Electrical Installations Must Comply With:
 In the U.S.A. National Electrical Code (NEC), ANSI/NFPA 70 and any other national, state, and local codes and/or regulations.
 In Canada, the Canadian Electrical Code (CEC), CSA C22.1 Canadian Electrical Code Part 1 and any other province, territory, local codes and/or regulations.

- | | | |
|--|---|---|
| <ul style="list-style-type: none"> (A) HMU Control Board (B) BCU Control Board (C) WP Control Board (D) HMI With WiFi Module (E) Power Switch (F) Field Wiring Connections | <ul style="list-style-type: none"> 1 Outdoor Temperature Sensor 3 Boiler Temperature Sensor 1 3A Boiler Temperature Sensor 2 5 DHW Temperature Sensor/Dry Contact 11 Ionization Signal 15 Flue Gas Temperature Sensor 20 Variable Speed Boiler Pump (Internal) 30 Diverting Valve Stepper Motor 35 Gas Valve 40 Power Supply 54 Ignition Transformer 96 Heat Demand Dry Contact | <ul style="list-style-type: none"> 100 Burner Fan Motor Power Supply 100A Burner Fan Motor Speed Control 163 Boiler Flow Switch P1 DHW Pump/DHW Recirculation Pump P2 Heating Zone Pump PWM Internal Pump Speed Control |
|--|---|---|

B1KE Models 120 / 199

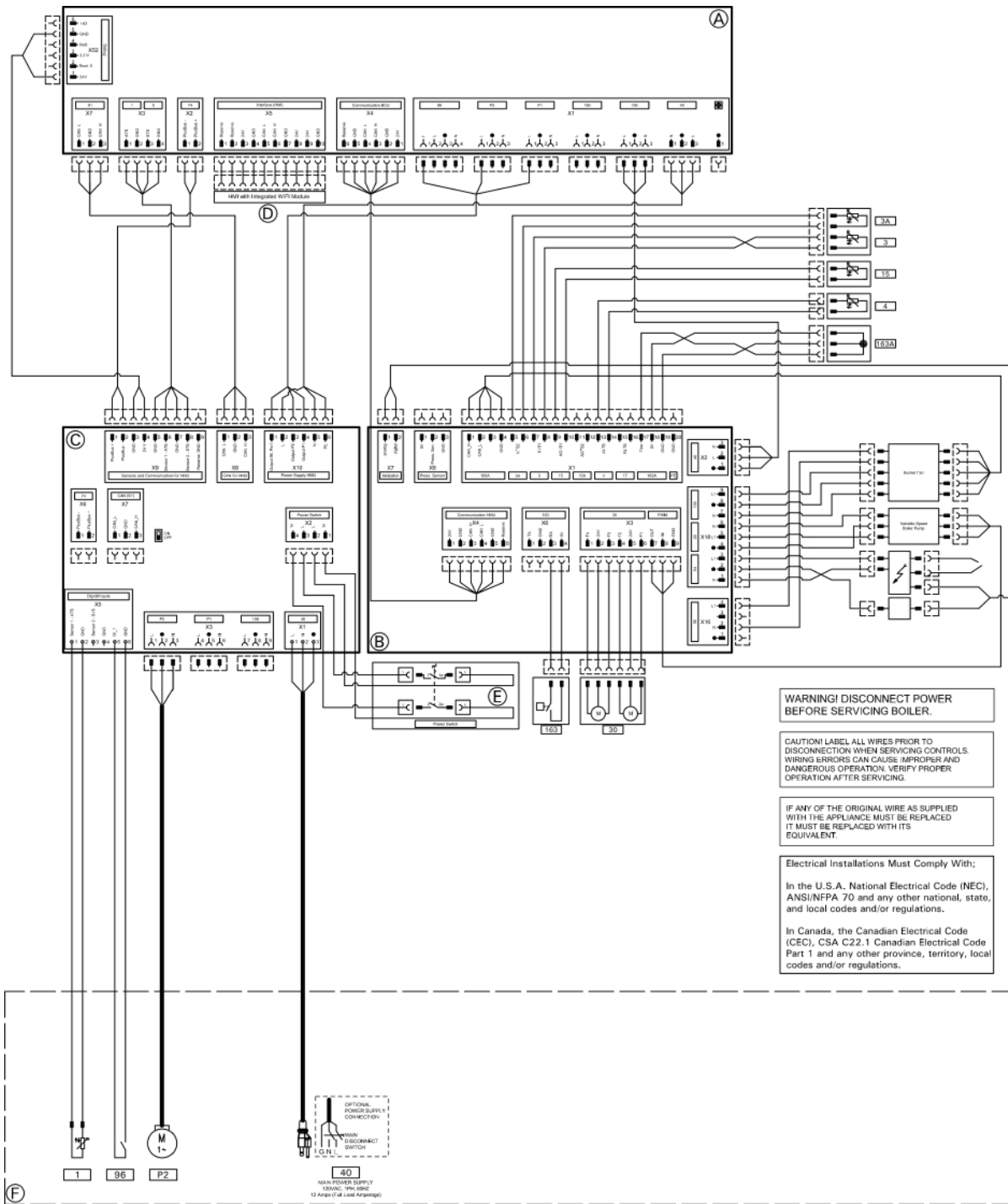

WARNING! DISCONNECT POWER BEFORE SERVICING BOILER.

CAUTION! LABEL ALL WIRES PRIOR TO DISCONNECTION WHEN SERVICING CONTROLS. WIRING ERRORS CAN CAUSE IMPROPER AND DANGEROUS OPERATION. VERIFY PROPER OPERATION AFTER SERVICING.

IF ANY OF THE ORIGINAL WIRE AS SUPPLIED WITH THE APPLIANCE MUST BE REPLACED IT MUST BE REPLACED WITH ITS EQUIVALENT.

Electrical Installations Must Comply With:
 In the U.S.A. National Electrical Code (NEC), ANS/NFPA 70 and any other national, state, and local codes and/or regulations.
 In Canada, the Canadian Electrical Code (CEC), CSA C22.1 Canadian Electrical Code Part 1 and any other province, territory, local codes and/or regulations.

- (A) HMU Control Board
 - (B) BCU Control Board
 - (C) WP Control Board
 - (D) HMI With WiFi Module
 - (E) Power Switch
 - (F) Field Wiring Connections
- | | |
|--|-------------------------------------|
| 1 Outdoor Temperature Sensor | 100 Burner Fan Motor Power Supply |
| 3 Boiler Temperature Sensor 1 | 100A Burner Fan Motor Speed Control |
| 3A Boiler Temperature Sensor 2 | 163 Boiler Flow Switch |
| 4 DHW Outlet Temperature Sensor | 163A DHW Flow Switch |
| 11 Ionization Signal | P2 Heating Zone Pump |
| 15 Flue Gas Temperature Sensor | PWM Internal Pump Speed Control |
| 20 Variable Speed Boiler Pump (Internal) | |
| 30 Diverting Valve Stepper Motor | |
| 35 Gas Valve | |
| 40 Power Supply | |
| 54 Ignition Transformer | |
| 96 Heat Demand Dry Contact | |

Boiler Flue and Combustion Air Connections

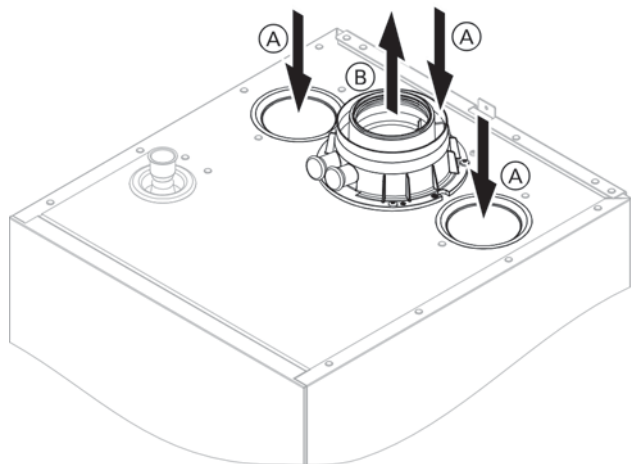

! WARNING

The combustion air cover is not pre-installed from factory on the concentric vent pipe adaptor, but is supplied with the boiler. Depending on the selected venting system and configuration selected this cover may need to be installed. Not installing this cover may cause unintended room air dependant operation (non-direct vent). Room air dependent operation requires provision of combustion and ventilation air (as per section "Single Pipe Venting" described in the Vitodens Venting Installation Instructions).

 Refer to Vitodens Venting Installation Instructions for additional information.

Legend

- Ⓐ Combustion air
- Ⓑ Flue gas

For direct vent applications the combustion air gaskets position can be interchanged. One gasket is sized for 3½ in. (89 mm) outside diameter (for CPVC/PVC/ABS), combustion air piping the other is sized for a 3⅞ in. (80 mm) outside diameter (for PPs) combustion air piping.

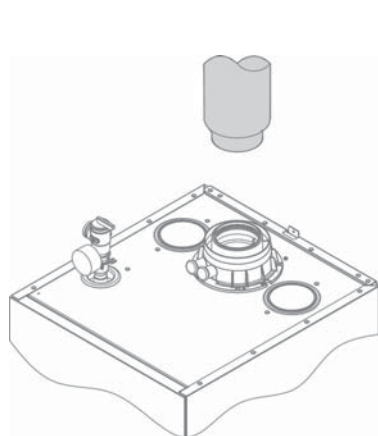

Coaxial

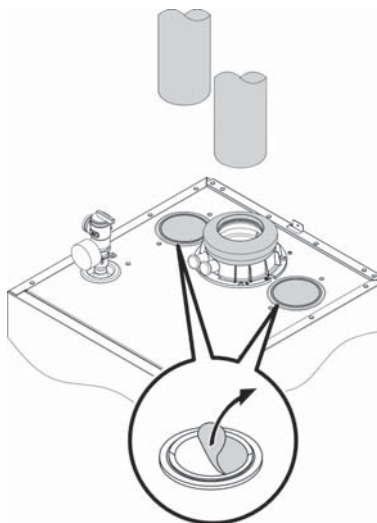

Direct Vent

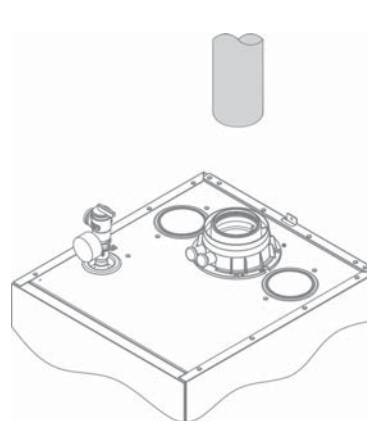

Room Air Dependant

Coaxial System

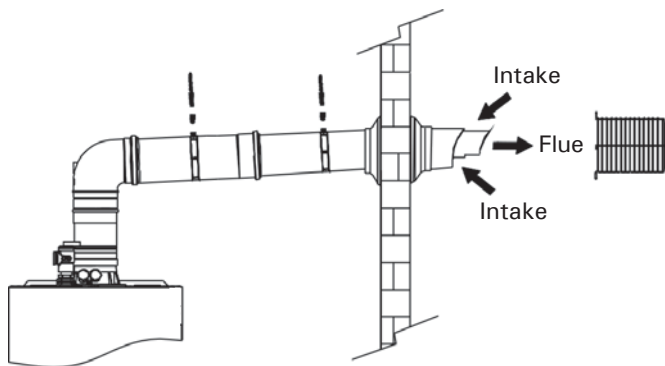

Coaxial			
Vent System (mm)	Equivalent Length		
	60/100	80/125	100/150 or 110/160
Boiler Models			
B1HE-85/120, B1KE-120	43 ft (13 m)	98 ft (30 m)	118 ft (36 m)
B1HE-150/199, B1KE-199	--	33 ft (10 m)	43 ft (13 m)

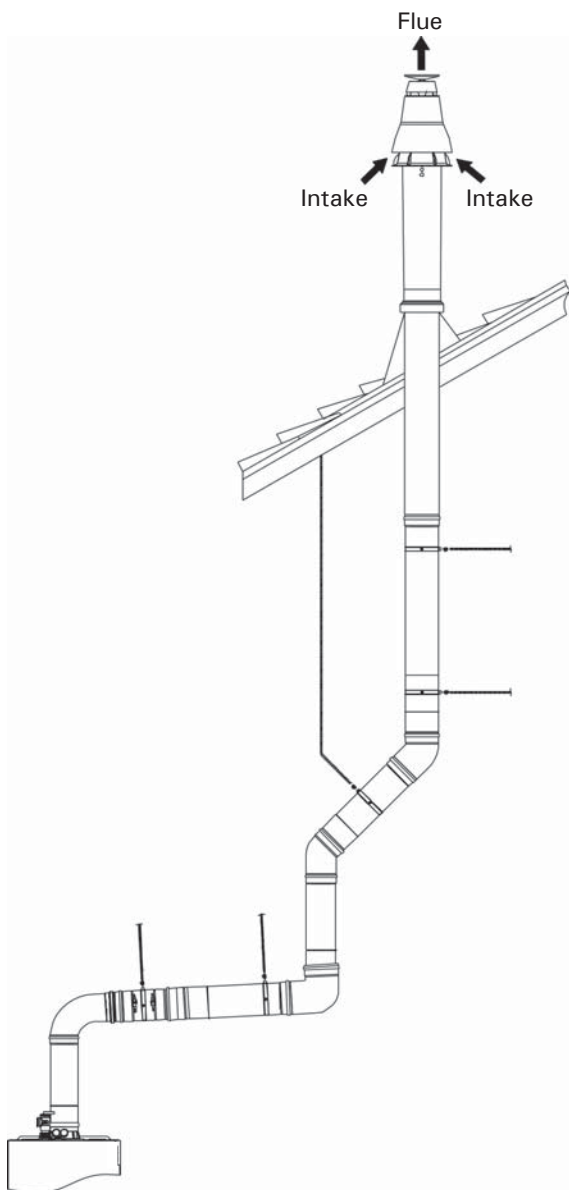

Two Pipe System

Two pipe system (room air independent) horizontally vented

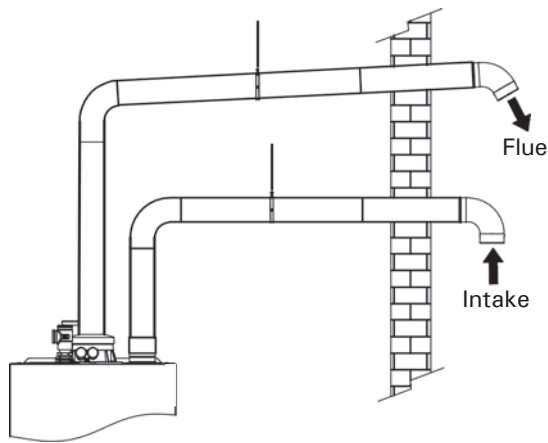

Two Pipe/Single Pipe

Vent System	Equivalent Length		
	2 in (60 mm)	3 in (80 mm)	4 in (110 mm)
Boiler Models			
B1HE-85	98 ft *1 (30 m)	164 ft (50 m)	198 ft (60 m)
B1HE-120 B1KE-120	98 ft *2 (30 m)	164 ft (50 m)	198 ft (60 m)
B1HE-150/199, B1KE-199	--	98 ft (30 m)	148 ft (45 m)

Combustion air: CPVC, PVC, ABS and stainless steel (field supplied)

Flue gas: CPVC, stainless steel and PP(s)

*1 There is an automatic input reduction reduction of 2%.

*2 There is an automatic input reduction reduction of 5%.

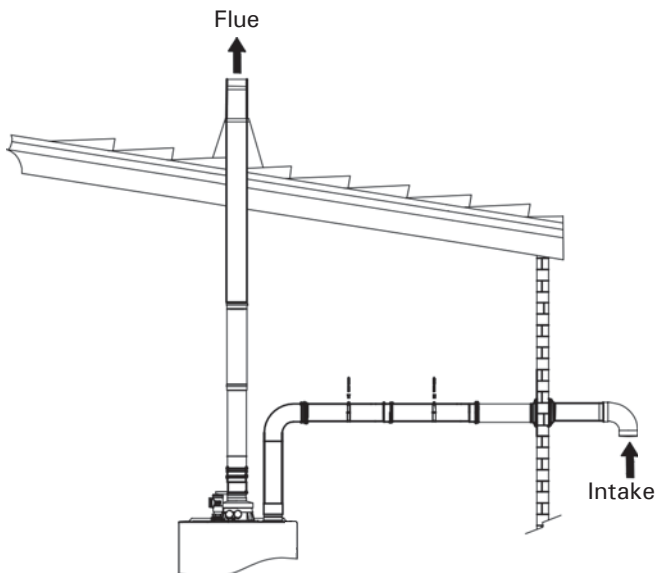
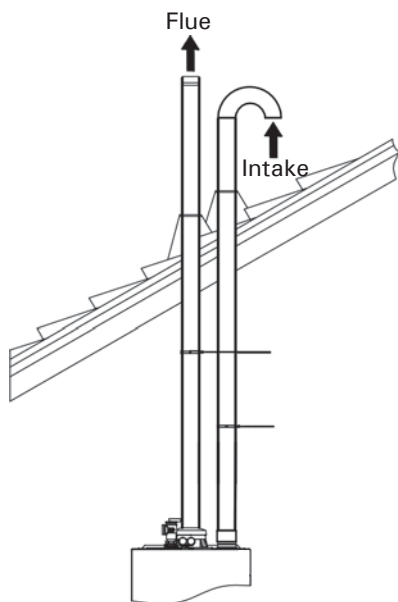

Single Pipe System

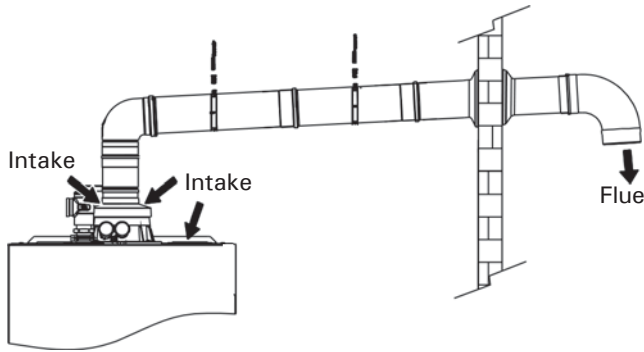

Single pipe system (room air dependant) horizontally vented

Two Pipe/Single Pipe

Vent System	Equivalent Length		
	2 in (60 mm)	3 in (80 mm)	4 in (110 mm)
Boiler Models			
B1HE-85	98 ft *1 (30 m)	164 ft (50 m)	198 ft (60 m)
B1HE-120 B1KE-120	98 ft *2 (30 m)	164 ft (50 m)	198 ft (60 m)
B1HE-150/199, B1KE-199	--	98 ft (30 m)	148 ft (45 m)

PP(s) (field supplied)

- *1 There is an automatic input reduction reduction of 2%.
- *2 There is an automatic input reduction reduction of 5%.

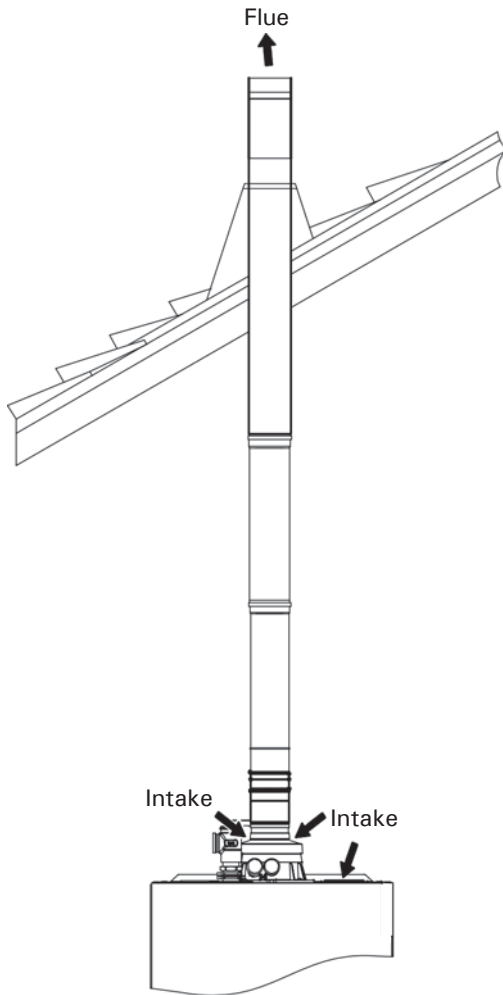

Flexible System

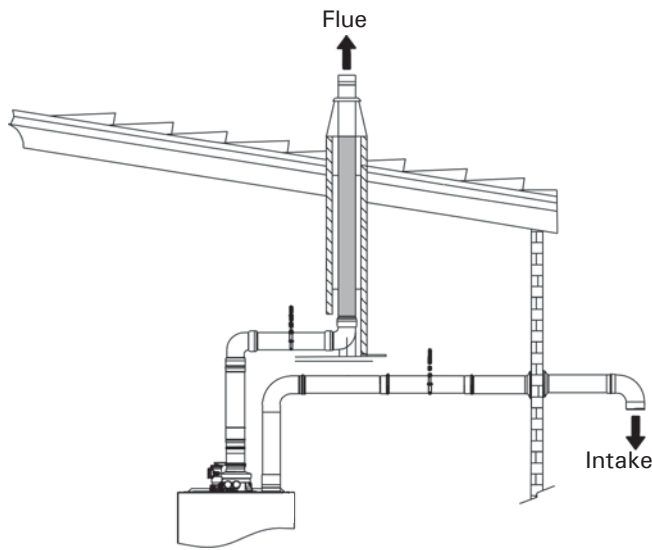

Flexible two pipe system (room air independent)

Two Pipe/Single Pipe

Vent System	Equivalent Length	
	3 in (80 mm)	4 in (110 mm)
Boiler Models		
B1HE-85/120, B1KE-120	123 ft (37 m)	148 ft (45 m)
B1HE-150/199, B1KE-199	72 ft (22 m)	111 ft (34 m)

Combustion air: CPVC, PVC, ABS and stainless steel
(field supplied)

Flue gas: PP(s) (Viessmann supplied)

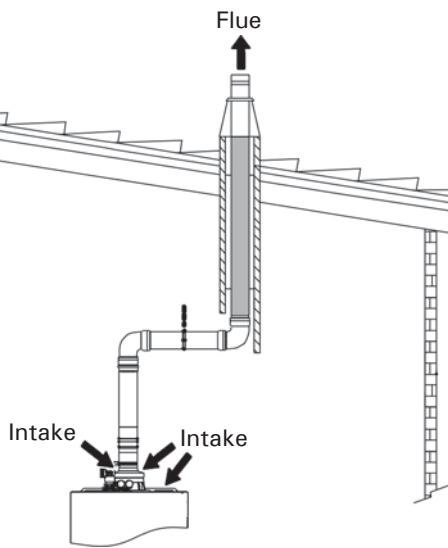

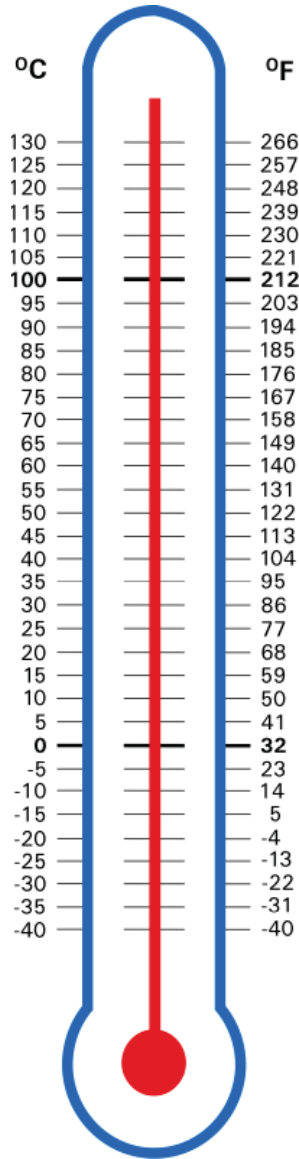

Printed on environmentally friendly
(recycled and recyclable) paper.

Technical information subject to change without notice.

Scan for
digital copy
of this
document



Viessmann Manufacturing Company Inc.
750 McMurray Road
Waterloo, Ontario • N2V 2G5 • Canada
TechInfo Line 1-888-484-8643
1-800-387-7373 • Fax (519) 885-0887
www.viessmann.ca • info@viessmann.ca

Viessmann Manufacturing Company (U.S.) Inc.
45 Access Road
Warwick, Rhode Island • 02886 • USA
TechInfo Line 1-844-649-5886
1-800-288-0667 • Fax (401) 732-0590
www.viessmann-us.com • info@viessmann-us.com