



# MODEL BF3 & BF5 INSTALLATION MANUAL

## RESIDENTIAL OIL BURNERS

**THIS BURNER IS NOT EQUIPPED FOR 2 LINE OPERATION.**

FOR 2 LINE OPERATION ORDER:  
PART # C7001025 FOR BF3, C7001026 FOR BF5

**IMPORTANT:** If this burner is being installed in a packaged unit (i.e. Burner comes with a boiler or furnace), follow the installation and set-up instructions supplied with the heating unit, as settings may differ from those shown in this manual.

C6505027 REV 6.1

---

---

## TABLE OF CONTENTS

---

---

TECHNICAL DATA - Model BF3.....	3
TECHNICAL DATA – Model BF5 .....	4
OIL BURNER COMPONENT IDENTIFICATION .....	5
Burner Components.....	5
Serial Number Identification.....	5
INITIAL SET-UP .....	5
MOUNTING BURNER TO BOILER OR FURNACE.....	6
Method 1 - Universal Mounting Flange .....	6
Method 2 - Pedestal Mount.....	7
ELECTRICAL CONNECTIONS.....	7
APPLICATION FIELD WIRING STANDARD (NO BURNER FAN OFF DELAY) .....	8
NOZZLE PLACEMENT .....	9
INSERTION/REMOVAL OF DRAWER ASSEMBLY.....	9
ELECTRODE SETTING.....	10
TURBULATOR SETTING.....	10
OIL LINE CONNECTIONS.....	10
Single Line (Gravity Feed).....	11
Two Line (Lift System).....	11
PUMP PURGE .....	12
Single Line (Gravity System).....	12
Two Line (Lift System).....	12
SETTING THE AIR DAMPER ADJUSTMENT.....	13
BF BURNER CHAMBER PRESSURE FIELD.....	13
BURNER ADJUSTMENT TABLES.....	14
BF BURNER TROUBLE SHOOTING CHART.....	15
BF BURNER INTAKE AIR LAYOUT.....	16
SPARE PARTS EXPLODED VIEW .....	17
SPARE PARTS LIST.....	18
PRECAUTIONS.....	19

### **ATTENTION:**

**The burner settings used in this manual were obtained under laboratory conditions and may vary from those obtained in the actual installation of the burner. Combustion results must be verified using proper combustion test equipment. Riello will not be responsible for the improper installation or set-up of the appliance.**

## RIELLO 40 BF3 TECHNICAL DATA

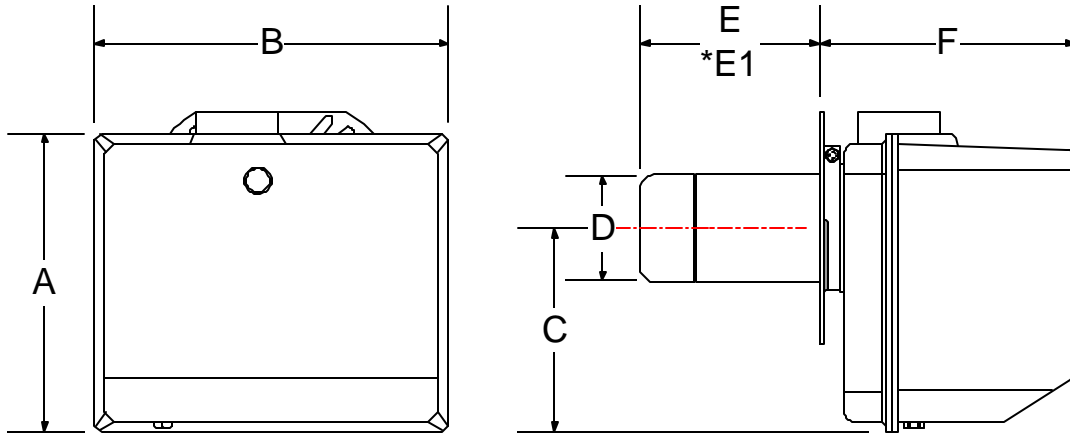

### DIMENSIONS

MODEL BF3	A	B	C	D	E	F
Inches	9 13/16	11 1/4	7 1/2	3 1/2	4 1/4	8 1/4
mm	249	286	193	89	108	210

\*E1: 6" (152 mm), 8 7/8" (225 mm) & 10" (254 mm) tubes are also available.

### SPECIFICATIONS

FUEL:	No. 2 Fuel Oil
FIRING RATE:	0.50 to 0.95 US GPH
EFFECTIVE OUTPUT:	70,000 to 133,000 BTU/h
VOLTAGE (Single Phase):	120V 60Hz (± 10% - 15%)
ABSORBED ELECTRICAL POWER:	192 Watts
MOTOR (rated):	3250 rpm Run Current 2.2 AMP
CAPACITOR:	12.5 Microfarads 260V
PUMP PRESSURE:	100 to 200 PSI
PRIMARY CONTROL:	RIELLO 530 SE/C
IGNITION TRANSFORMER:	8 kV 16mA *with intake air temperature at 20°C (68°F)

### MOUNTING FLANGE DIMENSIONS

MODEL BF3						
	A	B	C	D	E	F
Inch	7/16	7 3/32	3 9/16	5 9/16	7 9/16	8 1/2
mm	11	180	90	141	192	216

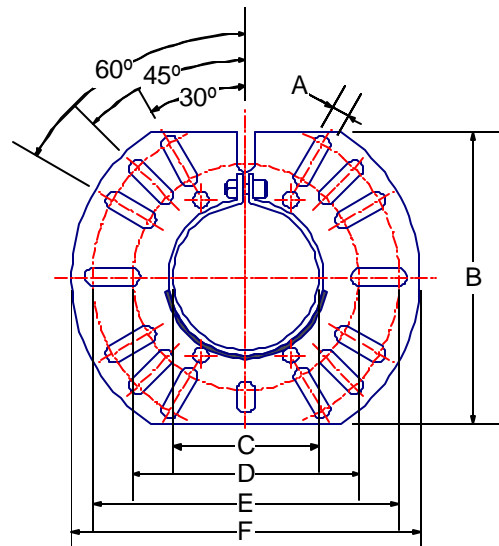

## RIELLO 40 BF5 TECHNICAL DATA

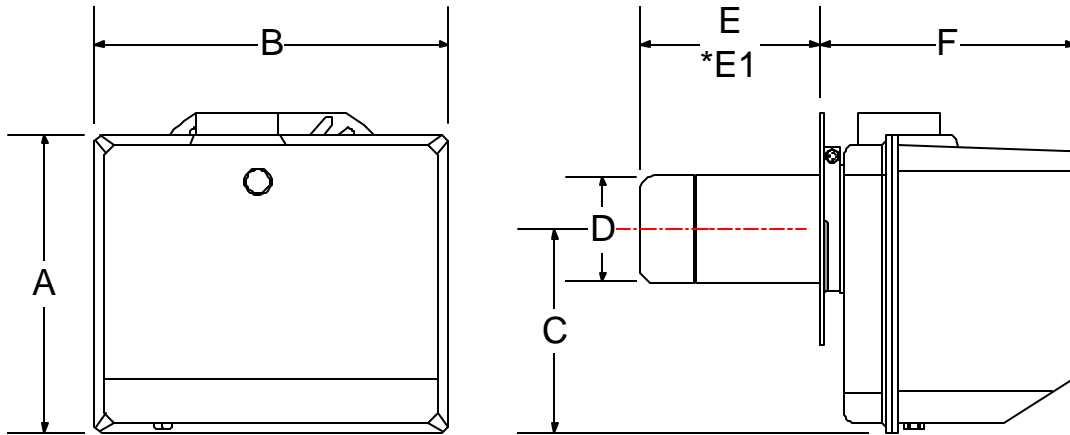

### DIMENSIONS

MODEL BF5	A	B	C	D	E	F
Inches	9 13/16	11 1/2	7 1/2	3 1/2	4 1/4	8 3/4
mm	249	292	193	89	108	222

\*E1: 6" (152 mm) & 10" (254 mm) tubes are also available.

### SPECIFICATIONS

FUEL:	No. 2 Fuel Oil
FIRING RATE:	0.75 to 1.65 US GPH
EFFECTIVE OUTPUT:	105,000 to 231,000 BTU/h
VOLTAGE (Single Phase):	120V 60Hz (± 10% - 15%)
ABSORBED ELECTRICAL POWER:	204 Watts
MOTOR (rated):	3250 rpm Run Current 2.2 AMP
CAPACITOR:	12.5 Microfarads 260V
PUMP PRESSURE:	100 to 200 PSI
PRIMARY CONTROL:	RIELLO 530 SE/C
IGNITION TRANSFORMER:	8 kV 16mA *with intake air temperature at 20°C (68°F)

### MOUNTING FLANGE DIMENSIONS

MODEL BF5						
	A	B	C	D	E	F
Inch	7/16	7 3/32	3 9/16	5 9/16	7 9/16	8 1/2
mm	11	180	90	141	192	216

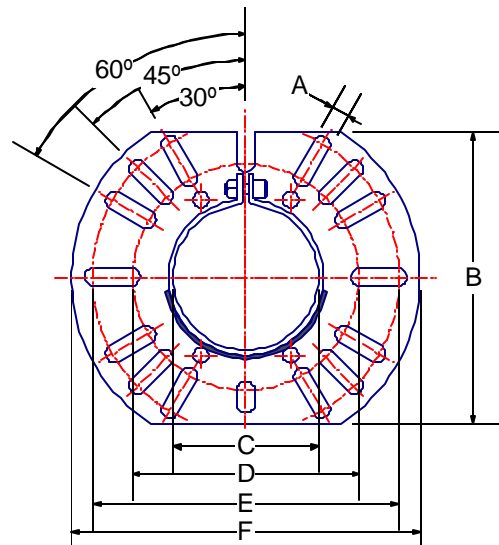

---



---

## RIELLO 40 SERIES OIL BURNER COMPONENT IDENTIFICATION

---



---

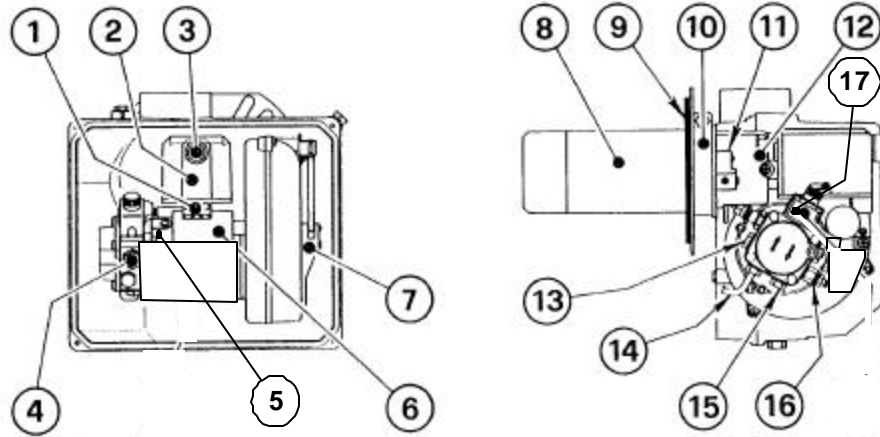

### BF3 & BF5 BURNER COMPONENTS

- |   |                                     |
|---|-------------------------------------|
| 1) Primary Control Sub-base                 | 10) Universal Mounting Flange       |
| 2) Primary Control                          | 11) Turbulator Adjustment Screw     |
| 3) Lockout Indicator Lamp and Reset Button  | 12) Air Tube Cover                  |
| 4) Pump Pressure Regulator Adjustment Screw | 13) Pump Plug                       |
| 5) Motor                                    | 14) Inlet Fuel Line Port            |
| 6) Capacitor                                | 15) Return Fuel Line Port           |
| 7) Air Damper                               | 16) Bleeder and Pressure Gauge Port |
| 8) End Cone Assembly                        | 17) Coil                            |
| 9) Mounting Gasket                          |                                     |

### SERIAL NUMBER IDENTIFICATION

The Riello 15 character serial number, example, **97 A 8511111 00025**, is identified as follow:

**97** = last two digits of the year of manufacture; **A** = BI-week of manufacture; **8511111** = burner product code; **00025** = increment of 1 for each burner produced – specific to product code – reset to zero each January 1<sup>st</sup>.

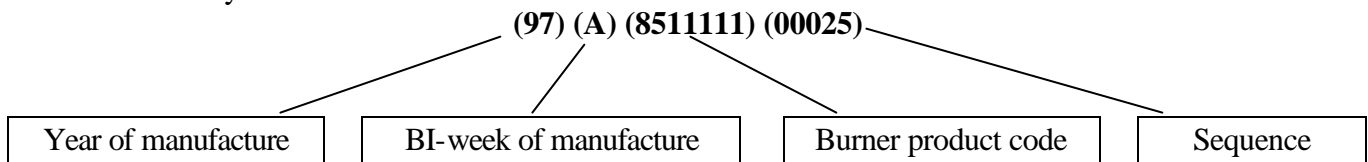

---



---

### INITIAL SET-UP

---



---

- A)** Remove burner from the carton. Check parts list (inside cover) to ensure all parts are present.
- B)** Remove burner cover by loosening the four screws securing it. Remove control box and air tube cover.
- C)** Remove drawer assembly, insert nozzle and set turbulator adjustment for specific input required.

---

---

## MOUNTING THE BURNER TO THE BOILER OR FURNACE

---

---

There are two possible methods to mount the burner, depending on the individual application. These are:

- 1) Universal flange bolted to Boiler/Furnace unit.
- 2) Universal flange mounted to optional Pedestal mount, where flange mounting direct to appliance is not possible. Pedestal kit must be ordered separately.

### METHOD 1 – UNIVERSAL MOUNTING FLANGE

- A) Slide the UNIVERSAL MOUNTING FLANGE (1) over the end cone assembly with the flat flange surface towards the heating unit.

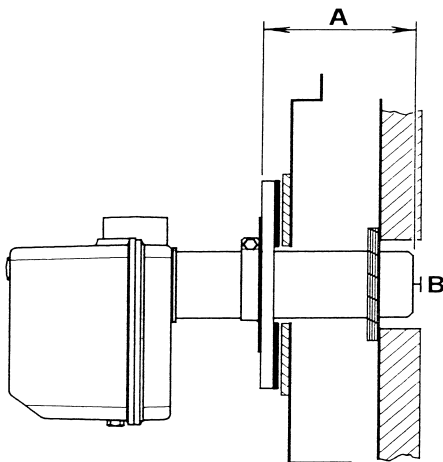
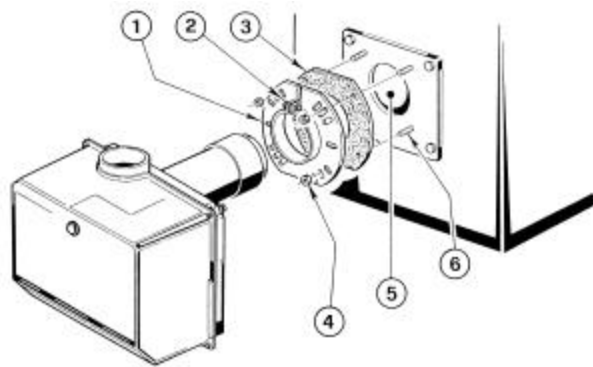

**WET BASED CHAMBER APPLICATIONS**

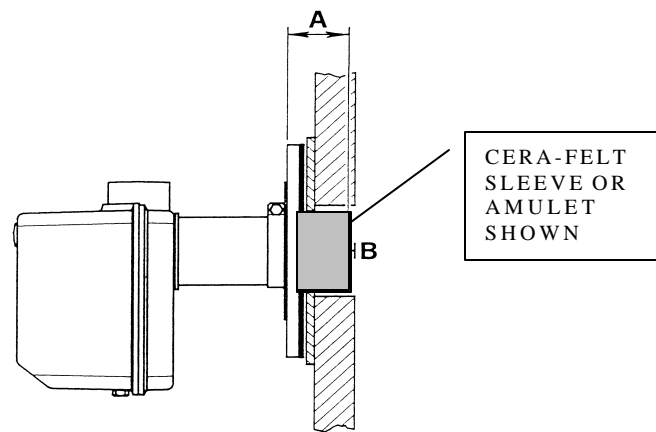

**DRY BASED CHAMBER APPLICATIONS**

- B) Secure the UNIVERSAL MOUNTING FLANGE to the AIR TUBE by tightening the ALLEN BOLT (2). Be sure that the MOUNTING FLANGE is properly positioned. The outer edge of the END CONE will be at least 1/4" (6.5 mm) back from the inside wall of the refractory chamber or inside wall of the combustion chamber (see dimension B above). The measured length (A) is to include the MOUNTING GASKET (3) and FLANGE.
- C) For dry based appliances it is suggested that an amulet or cera-felt sleeve be used on the end cone to help reduce the risk of end cone burn-off. This amulet also provides an additional benefit of sealing the chamber air tube hole when this hole is larger than our air tube diameter. Please refer to amulet instructions in regards to installing amulet to the burners air tube end cone.

D) The burner can now be attached to the heating unit by inserting the AIR TUBE through the BURNER ACCESS HOLE (6) and into the appliance, making sure the MOUNTING FLANGE lines up with the appliance studs (6). Secure the burner in place using nuts (4).

A visual verification of the air tube insertion into the combustion chamber of the heating unit is suggested. Dimension "B" should be at least ¼ inch (see drawing).

## METHOD 2 – PEDESTAL MOUNT

Secure the MOUNTING FLANGE to MOUNTING PEDESTAL using the hardware provided with the pedestal. Secure burner to MOUNTING FLANGE as in METHOD 1.

NOTE: It is suggested that the pedestal be anchored in position on the floor by installing brackets over the pedestal tube and securing brackets to the floor.

**WARNING:** WHEN THE COMBUSTION CHAMBER IS LINED WITH A REFRACTORY MATERIAL, IT IS IMPERATIVE THAT THE END CONE NOT PROTRUDE INTO THE CHAMBER AREA, AS EXCESSIVE HEAT AT BURNER END CONE DURING OPERATION OR SHUTDOWN WILL DAMAGE THE END CONE. IF HIGH END CONE TEMPERATURES ARE A CONCERN USING A CERA-FELT SLEEVE OR, AMULET OVER THE END CONE COULD HELP REDUCE THE RISK OF BURN-OFF THE END CONE.

---

---

## ELECTRICAL CONNECTIONS

---

---

It is advisable to leave the control box off the sub-base while completing the electrical connections to the burner.

- 1) Electrical connector
- 2) Earth ground conductor terminal

The burner may be controlled using either a DIRECT LINE VOLTAGE control circuit (120V AC 60 cycle) OR a LOW VOLTAGE control (24V AC 60 cycle) using models Riello or Honeywell R8038A 24v relays.

Following the wiring diagram on the next page, make electrical connections to burner. All wiring must be done in accordance with existing electrical codes, both National and Local.

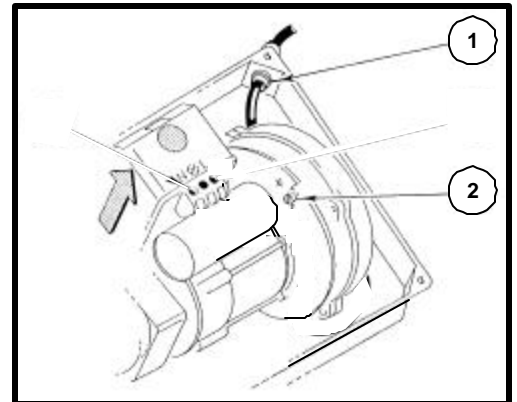

**WARNING:** DO NOT activate burner until proper oil line connections have been made, or failure of the pump shaft seal may occur.

## APPLICATION FIELD WIRING – STANDARD

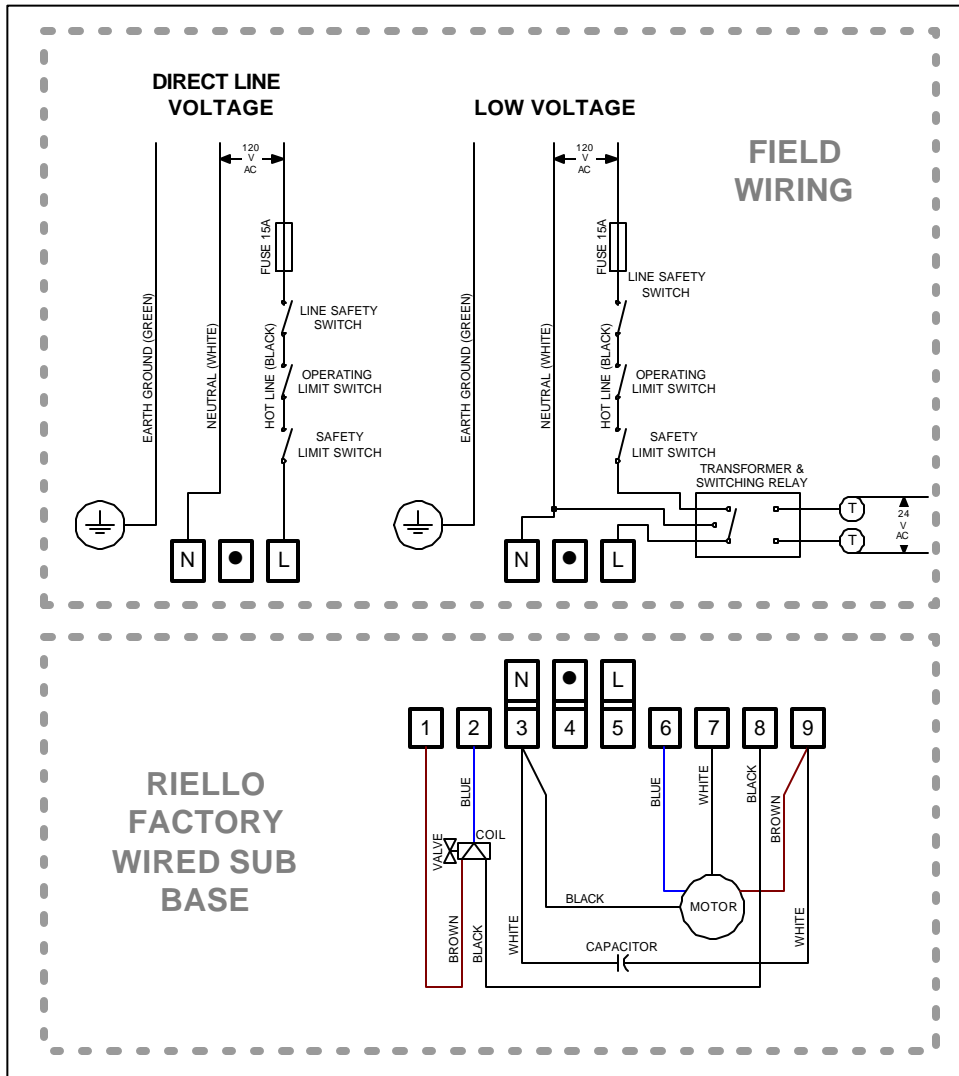

**REMOTE SENSING OF SAFETY LOCKOUT:** The SAFETY SWITCH in the 530SE CONTROL BOX is equipped with a contact allowing remote sensing of burner lockout. The electrical connection is made at terminal 4 (•) on the SUB-BASE. Should lockout occur the 530SE CONTROL BOX will supply a power source of 120Vac to the connection terminal. The maximum allowable current draw on this terminal (4) is 1 Amp.

**WARNING:** *If a neutral or ground lead is attached to this terminal, the CONTROL BOX on the burner will be damaged should lockout occur.*



---

---

## NOZZLE PLACEMENT

---

---

- A) Determine the proper firing rate for the boiler or furnace unit, considering the specific application and use the Burner Set-Up charts on page 14 to select the proper nozzle and pump pressure to obtain the required input from the burner.
- B) Remove the NOZZLE ADAPTER (2) from the DRAWER ASSEMBLY by loosening the SCREW (1).
- C) Insert the proper NOZZLE into the NOZZLE ADAPTER and tighten securely (DO NOT over tighten).
- D) Replace adapter, with nozzle installed, into drawer assembly and secure with screw (1).

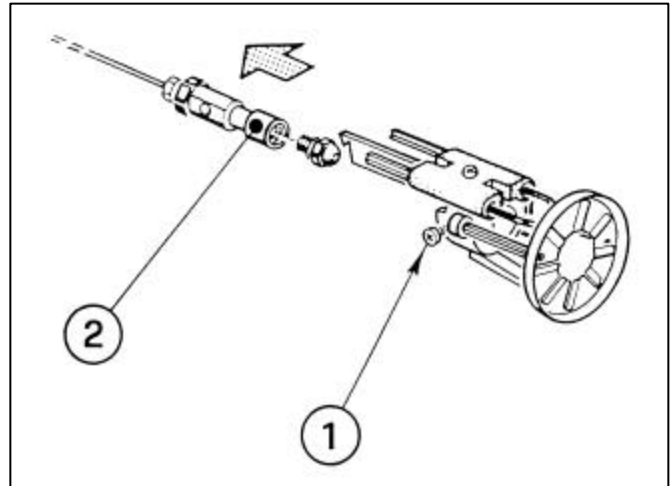

---

---

## INSERTION/REMOVAL OF DRAWER ASSEMBLY

---

---

- A) To remove drawer assembly, loosen SCREW (3), and then unplug CONTROL BOX (1) by carefully pulling it back and then up.
- B) Remove the AIR TUBE COVER PLATE (5) by loosening the retaining SCREW (4) (Two SCREWS – Model BF5).
- C) Loosen SCREW (2), and then slide the complete drawer assembly out of the combustion head as shown.
- D) To insert drawer assembly, reverse the procedure in items A to C above, and then attach fuel line to the pump.

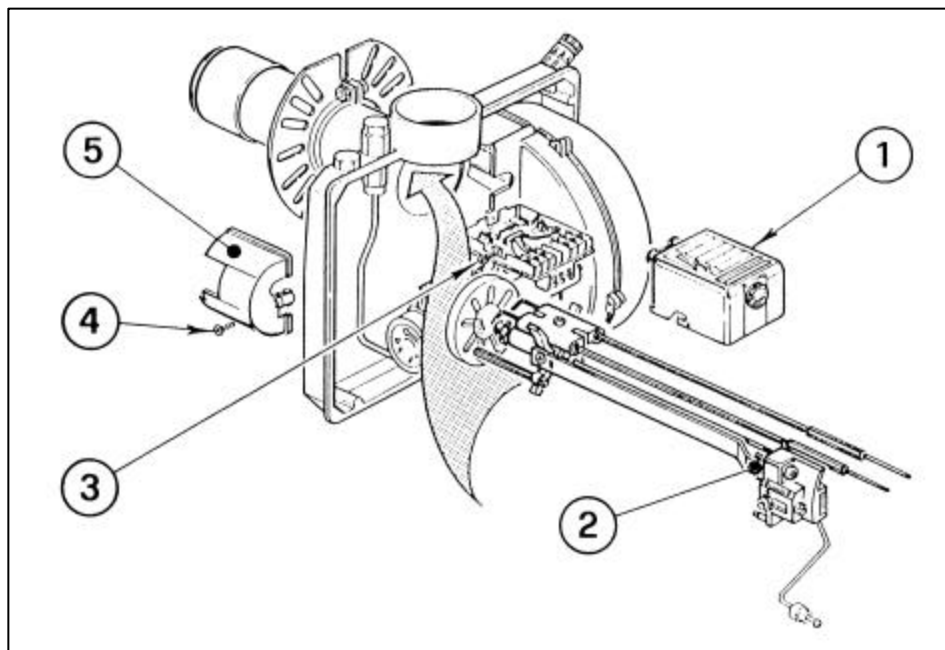

---

---

## ELECTRODE SETTING

---

---

**IMPORTANT:** THESE DIMENSIONS MUST BE OBSERVED AND VERIFIED

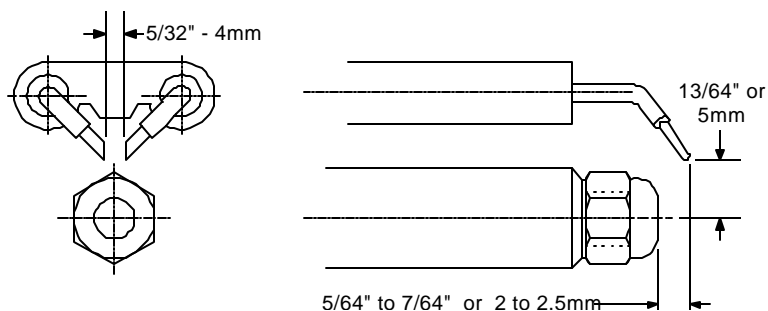

---

---

## TURBULATOR SETTING

---

---

- A) Loosen NUT (1), and then turn SCREW (2) until the INDEX MARKER (3) is aligned with the correct index number as per the Burner Setup charts, on page 14.
- B) Retighten the RETAINING NUT (1).

**NOTE: MODEL BF3:** Zero and three are scale indicators only. From left to right, the first line is 3 and the last line 0.

**MODEL BF5:** Same as above except scale indicators are 0 and 4.

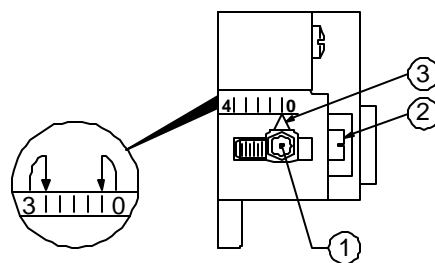

---

---

## OIL LINE CONNECTIONS

---

---

**WARNING:** The burner is shipped with the pump set to operate on a ONE-line system. To operate on a Two-line system, the by-pass plug (3) must be installed.

### To install the by-pass plug:

- 1) Remove the plug from the return port of the pump.
- 2) Insert the by-pass (3) plug into the return port of the pump and screw into place.
- 3) Connect the return line connection pipe (4) to the return port of the pump and tighten securely.

**NOTE:** Pump pressure **must** be set at time of burner startup. Attach a pressure gauge to the PRESSURE PORT (2) for pressure readings. All pump port threads are **British Parallel thread** design. Direct connection of NPT threads to the pump will damage the pump body. Riello manometers and vacuum gauges do **not** require any adapters, and can be safely connected directly to pump ports. An NPT (metric) adapter must be used when connecting other gauge models.

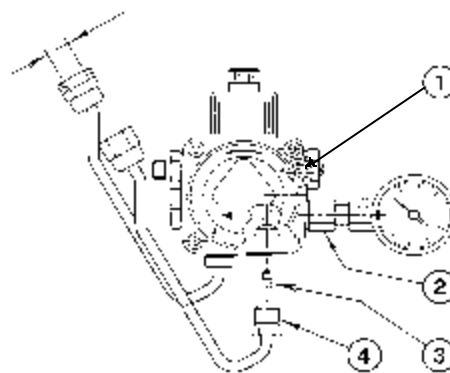
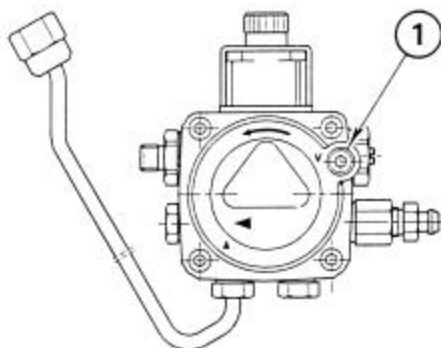

## SINGLE LINE (GRAVITY FEED)

Install the required fitting NPTF to NPT adapter into the pump's SUCTION LINE CONNECTION FITTING on left side of burner on top. Attach the required tubing to this fitting. Be sure that the plug in the RETURN LINE CONNECTION FITTING is tightened securely.

SINGLE LINE SYSTEM-PIPE LENGTHS					
H		3/8" OD	1/2" OD		
FT	M	FT	M	FT	M
1.5	0.5	33	10	65	20
3.0	1.0	65	20	130	40
5.0	1.5	130	40	260	80
6.5	2.0	195	60	325	100

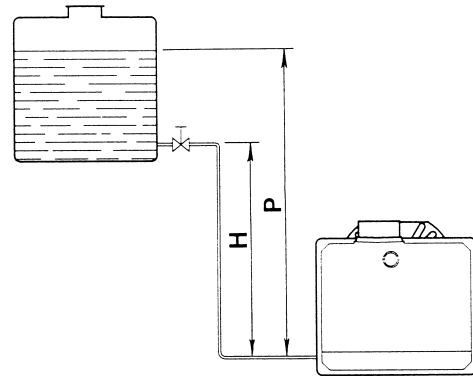

## TWO LINE (LIFT SYSTEM) (Accessory package required)

Convert the pump for operation as a two-line system by installing the by-pass plug.

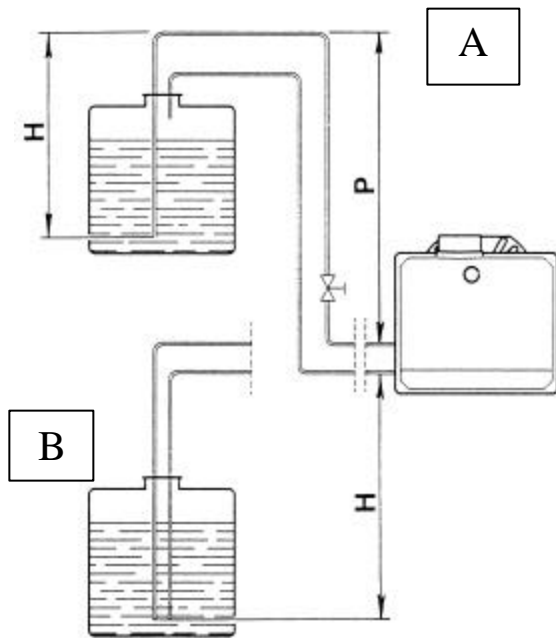

2 LINE (LIFT) SYSTEM-PIPE LENGTHS					
H		3/8" OD	1/2" OD		
FT	M	FT	M	FT	M
0.0	0.0	115	35	330	100
1.5	0.5	100	30	330	100
3.0	1.0	80	25	330	100
5.0	1.5	65	20	295	90
6.5	2.0	50	15	230	70
9.5	3.0	25	8	100	30
11	3.5	20	6	65	20

- A) Suction and return lines should be sized in accordance with local codes. The suction line should extend down near the bottom of the oil tank. The return line should terminate near the top of the oil tank.
- B) Suction and return lines should be sized in accordance with local codes and both **should extend to the same depth inside the fuel tank**. Be sure there are no air leaks or blockages in the piping system. Any obstructions in the return line will cause failure of the pump shaft seal. Do not exceed the pipe lengths indicated in the tables on page 11.

Install the required fittings (NPT THREAD) in the SUCTION LINE and RETURN LINE CONNECTION FITTINGS. Attach the required tubing to these fittings.

**WARNING: Pipe dope or Teflon tapes are NOT to be used on any direct oil connection to the**

**fuel pump.**

**WARNING: The height "P" in Pipe Length charts on page 11 should not exceed 13 feet (4m).**

**WARNING: The vacuum should not exceed 11.44 inches of mercury.**

**WARNING: An external, appropriately listed and certified oil filter must be placed in the fuel line between the fuel tank and the burner pump.**

---

---

## PUMP PURGE

---

---

**NOTE:** To protect the pump gears. It is advisable to lubricate the pump before purge all air out of oil line(s) system. Apply oil through the VACUUM PORT.

### 1) SINGLE LINE (GRAVITY SYSTEM)

Turn off all power to burner/appliance, and then attach a hose over bleeder plug fitting put other end of hose into a bucket. Loosen bleeder plug, when oil comes out of bleeder plug and appears clear tighten bleeder port plug, and remove hose. The burner should have purge all air of pump, and oil line and burner is ready to operate.

### 2) TWO LINE (LIFT SYSTEM) 2 options

A) Turn off the main power source to the burner and remove the air tube cover. Shine a light source on the photocell on the control box (now visible where the air tube cover was removed), return power to the burner and activate the burner. With the light source in place, the burner will operate in prepurge only. Once the burner is purged, turn off the power source and replace the air tube cover. Return power to the burner. The burner is now ready to operate.

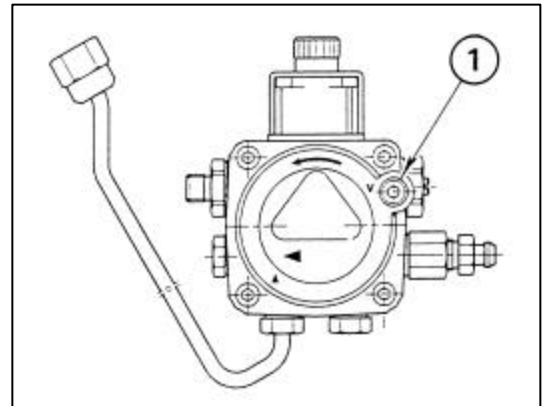

B) Turn off the main power source to the burner/appliance and then remove control box module. Get a jumper wire and jumper sub-base terminals # 5 & # 6, this will operate the motor and pump only with the control module off. Attach a hose over the bleeder port fitting and put the other end into a bucket. Restore power and run burner without control box module until oil flows out of bleeder port fitting and appears to be clear. Remove power and reinstall control box module, now the burner is ready to operate.

**ATTENTION: It is important that the fuel line be completely sealed and free from air leaks or any internal blockages.**

**WARNING! WHEN THE BYPASS PLUG IS INSTALLED, A TWO-PIPE SYSTEM MUST BE USED OR FAILURE OF THE PUMP SHAFT SEAL WILL OCCUR.**

---

---

## SETTING THE AIR DAMPER ADJUSTMENT

---

---

- A) The initial air damper setting is made by turning screw (2) until the top edge of the air damper (3) is aligned with the number according to the burner setup chart.
- B) Further adjustments can be made with the burner cover in place by removing plastic plug on the top right hand side of the cover. Turn the screw counter clockwise (+ indicator) to increase combustion air, turn the screw clockwise (- indicator) to decrease combustion air.
- C) The final position of the air damper will vary on each installation. Use instruments to establish the proper settings for maximum CO<sub>2</sub> and a smoke reading of zero.

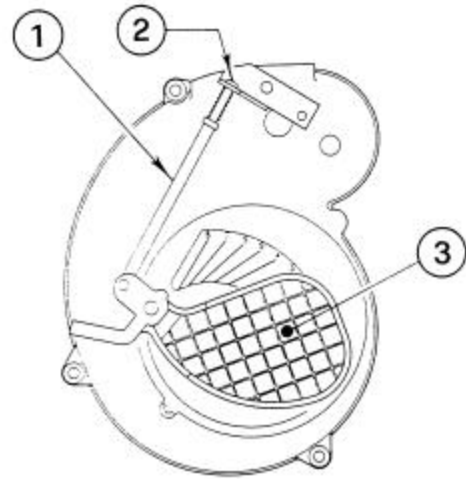

**NOTE:** Variations in flue gas, smoke, CO<sub>2</sub>, and temperature readings may be experienced when the burner cover is put in place. Therefore, the burner cover **must** be in place when making the final combustion instrument readings, to ensure proper test results.

---

---

## COMBUSTION CHAMBER PRESSURE CHART

---

---

BURNER OUTPUT VS CHAMBER PRESSURE CHART

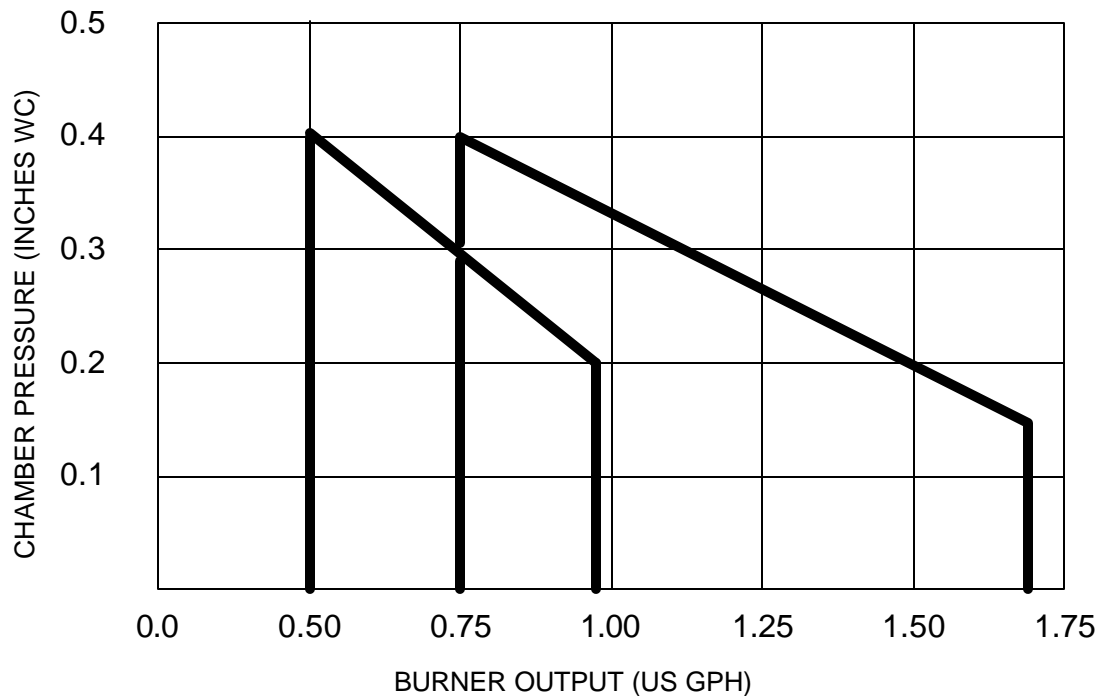

## BURNER ADJUSTMENT TABLES

**IMPORTANT:** The following charts indicate initial setting with combustion air at 20°C (68°F).

### MODEL BF3 BURNER SETUP CHART

1 ACTUAL FIRING RATE 5% ± US GPH	2 NOZZLE SIZE GPH	3 PUMP PRESSURE		4 TURBULATOR SETTING	5 AIR DAMPER SETTING
		PSI	BAR		
0.50	0.40 X 60/ 80°	160	11	0.0	3.2
0.60	0.50 X 60/ 80°	145	10	1.0	3.8
0.75	0.60 X 60/ 80°	160	11	1.5	4.4
0.80	0.65 X 60/ 80°	150	10	2.0	5.0
0.95	0.75 X 60/ 80°	160	11	3.0	7.0

### MODEL BF5 BURNER SETUP CHART

1 ACTUAL FIRING RATE 5% ± US GPH	2 NOZZLE SIZE GPH	3 PUMP PRESSURE		4 TURBULATOR SETTING	5 AIR DAMPER SETTING
		PSI	BAR		
0.75	0.65 X 60/ 80°	145	10	0.0	3.3
0.85	0.75 X 60/ 80°	145	10	0.5	3.5
1.00	0.85 X 60/ 80°	145	10	1.0	4.0
1.10	1.00 X 60/ 80°	145	10	1.5	4.5
1.25	1.10 X 60/ 80°	145	10	2.0	5.0
1.50	1.25 X 60/ 80°	145	10	3.0	6.0
1.65	1.35 X 60/ 80°	145	10	4.0	7.0

?? Actual input values given in above table are based on zero (0) chamber pressure, fired in Riello Canada Inc. Test Lab DIN (small) test boiler (chamber length 17", chamber diameter of 11"). Input values calculated using pump pressures listed above in the set-up table. Some variations will occur depending on application. This above set-up table is used to assist in the initial set-up only. Proper test equipment must be used to set the burner up properly.

?? Please refer to appliance literature or recommendation regarding nozzle size, spray pattern and spray angle. If no suggestions or literature are given, using above set-up table for desired input value set burner to table setting until burner is firing then make suitable adjustments to burner to achieve desirable combustion results.

**MODEL BF3 & BF 5 NOZZLES:** Any nozzle manufacturer, size, and angle spray pattern. The appliance in which the burner is installed into determines BF burner nozzle selection.

### COMBUSTION CHAMBER

Follow the instructions furnished by the boiler/furnace manufacturer. Size retrofit application according to the appropriate installation codes (e.g. CSA B139 or NFPA #31).

### NON-RETROFIT APPLICATIONS

If this BF burner is packaged with the appliance, it is considered an OEM package; please read all instructions the related to the burner, this information will supercede our installation manual.

**RIELLO 40 SERIES BF OIL BURNER  
TROUBLE SHOOTING CHART**

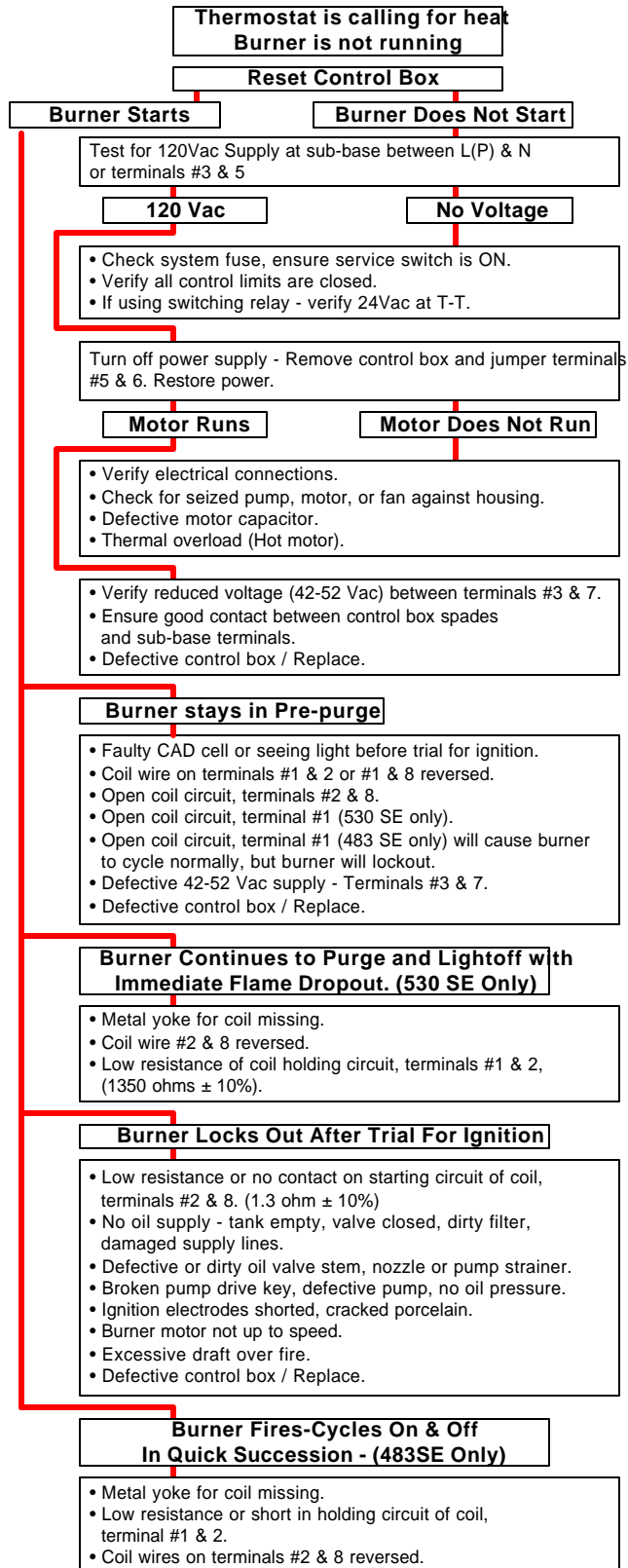

---

---

## A TYPICAL LAYOUT FOR BF BURNER INTAKE AIR

---

---

- A) Use an approved air intake kit.
- B) Always keep intake air run to the minimum.
- C) Maximum intake air run of 4 (inch) diameter, flexible or rigid type of venting = 100'
- D) Reduce intake air length by 10' for every 90° elbow used. 5' for every 45° elbow used.
- E) It is suggested that air intake venting be insulated with R7 (min) foil lined insulation a minimum of 10' from air intake source. (Prevent condensation or corrosion of intake air venting)
- F) Used approved type of intake air vacuum breaker and to be installed in the same room and the burner, for the event of intake air source being blocked, this device should be tested to prove that in the event of intake air source is blocked that the vacuum breaker balancer is set correctly and can provide sufficient air for combustion for the burner. If the room that the burner is installed into cannot provide enough air or air quality is a concern, an additional air inlet source will have to be providing to this room.

**IF THIS BF BURNER IS INSTALLED ON AN OEM APPLIANCE PLEASE REFER TO INTAKE AIR LAYOUT SUGGESTED IN THEIR LITERATURE.**

### **THIS INTAKE AIR LAYOUT FOR CHIMNEY APPLICATIONS ONLY**

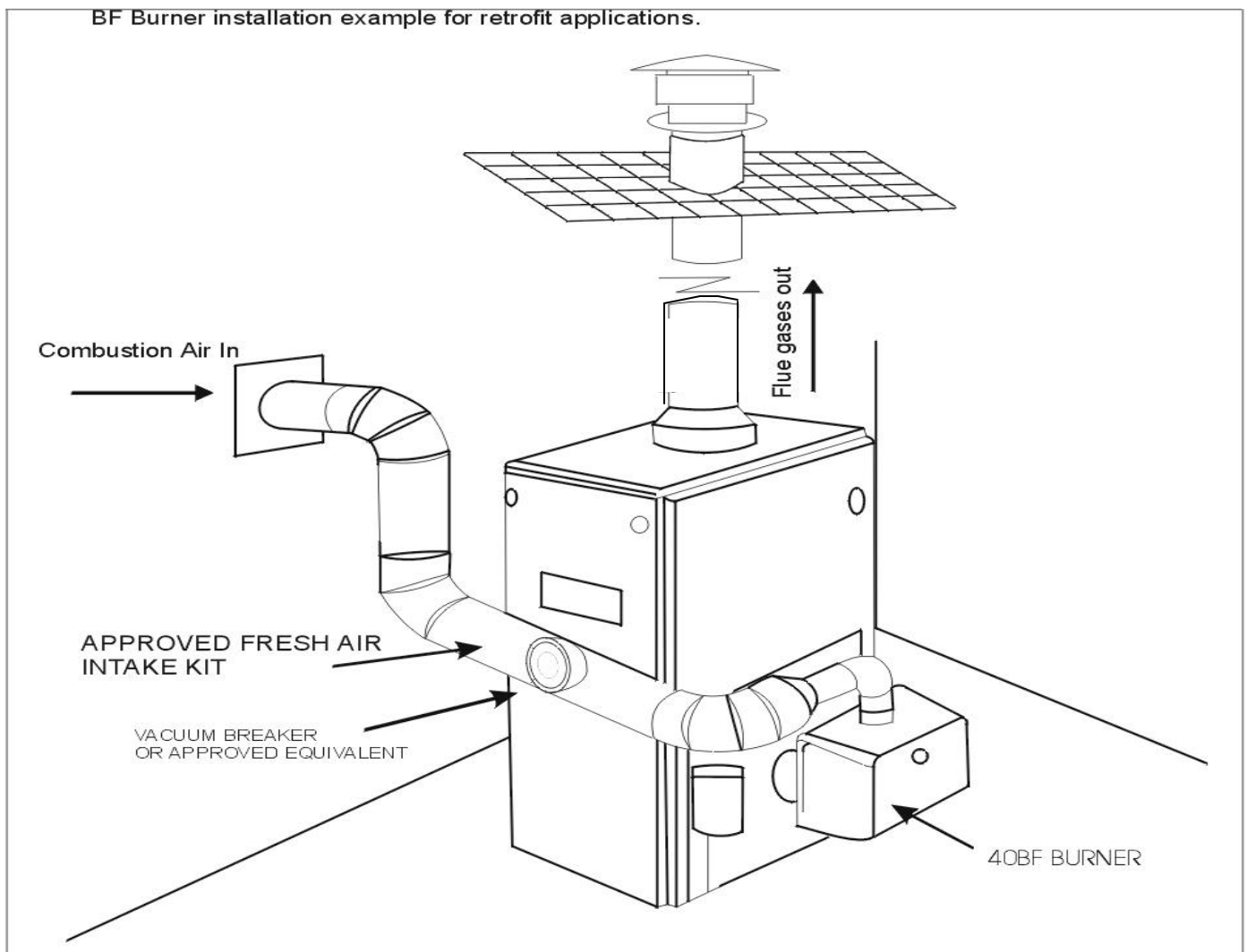

October 31/98



# SPARE PARTS

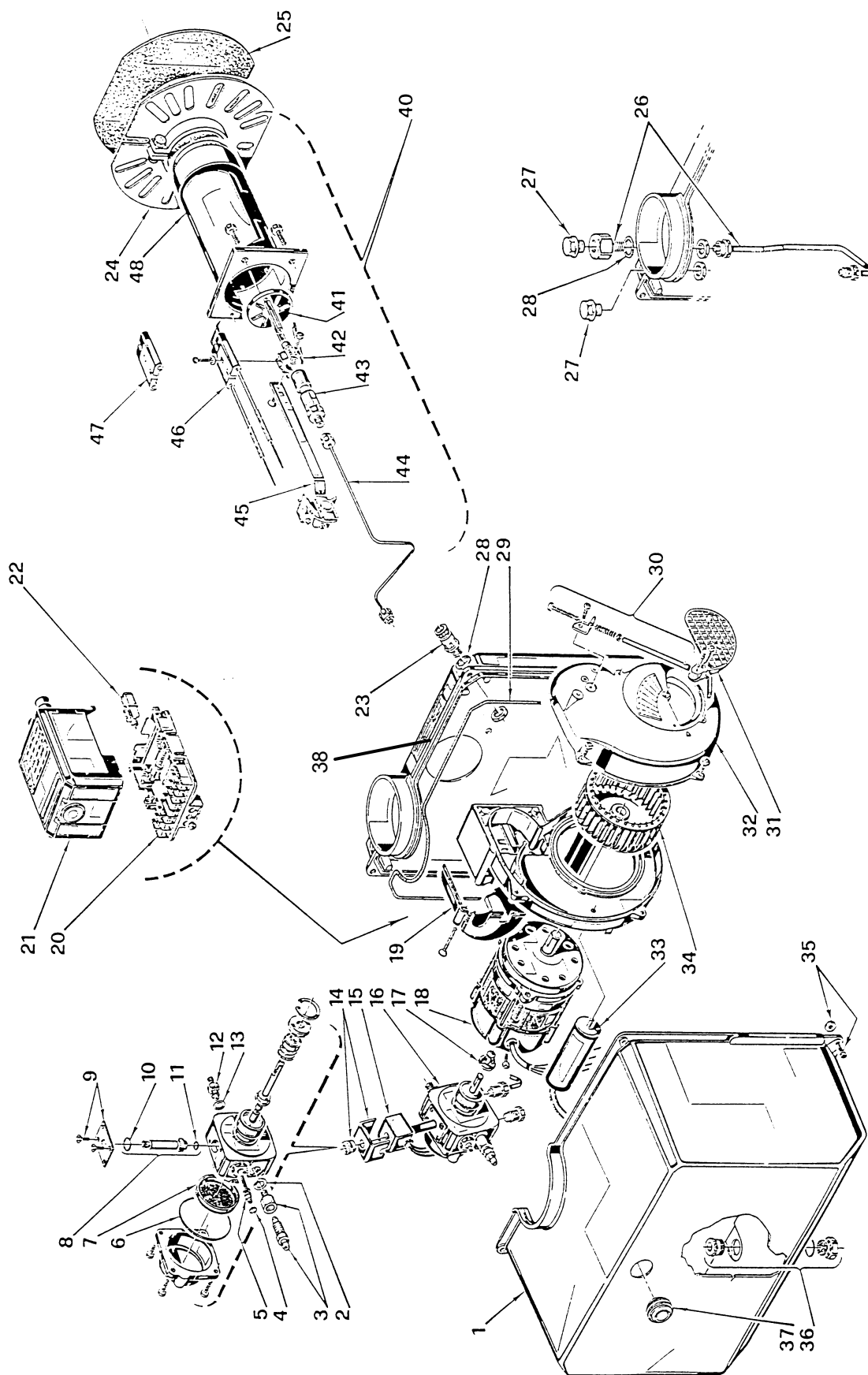

## RIELLO BF3 & BF5 SPARE PARTS LIST

• Indicates applicable model for each part.

No	CODE	BF3	BF5	DESCRIPTION	No	CODE	BF3	BF5	DESCRIPTION
1	3008019	•		Burner Cover	22	3002280	•	•	Photo Cell
	3008023		•	Burner Cover	23	C5283000	•	•	Electrical Fitting
2	3007077	•	•	Crushable Metal Washer 3/8" ID.	24	3000932	•	•	Moveable Flange
3	3007568	•	•	Bleeder	25	3005856	•	•	Mounting Gasket
4	3007028	•	•	O-Ring – Pump Pressure Regulator	26	3008020	•		Oil Supply Tube & Adapter Fitting
5	N/A	•	•	Regulator		3008024		•	Oil Supply Tube & Adapter Fitting
6	C7010002	•	•	O-Ring – Pump Cover	27	3007901	•	•	Plug
7	3005719	•	•	Pump Screen	28	N/A			Adapter Washer
8	3006925	•	•	Valve Stem	29	3007630	•	•	Gasket – Burner Cover
9	3007203	•	•	Plate – Valve Stem Retainer	30	3000681	•	•	Manual Air Damper Regulator
10	3007029	•	•	O-Ring – Valve Stem, upper	31	3008021	•	•	Air Damper
11	3007156	•	•	O-Ring – Valve Stem, lower	32	3007207	•		Air Intake Housing
12	3007268	•	•	Nozzle Outlet Fitting		3007824		•	Air Intake Housing
13	3007087	•	•	Crushable Metal Washer 5/8" ID	33	3005844	•	•	Capacitor 12.5µF
14	3006553	•	•	Coil U-bracket and Retainer Nut	34	3005708	•	•	Fan
15	3002279	•	•	Coil	35	3007707	•	•	Cover Screw and Washer
16	3007802	•	•	Pump	36	3007628	•	•	Filter Assembly
17	3000443	•	•	Pump Drive Key	37	3007627	•	•	Plug–Cover Opening–Burner Reset
18	3005843	•	•	Motor 120V 60Hz	38	3008078	•		Back plate
19	3007315	•	•	Air Tube Cover Plate		3008079		•	Back plate
20	3002278	•	•	Primary Control Sub Base		C7001084			AL1009 Post Purge Control (not shown)
21	3001157	•	•	Primary Control 530 SE/C					
<b>VERY SHORT 3" COMBUSTION HEAD</b>					<b>8 7/8" COMBUSTION HEAD</b>				
40	3948876	•		VSBT Combustion Head	40	3948877	•		Combustion Head
	3948976		•	VSBT Combustion Head		3948975		•	Combustion Head
41	3006968	•		Turbulator Disc	41	3006968	•		Turbulator Disc
	3006977		•	Turbulator Disc		3006977		•	Turbulator Disc
42	3006966	•	•	Electrode Support	42	3006966	•	•	Electrode Support
43	3006965	•	•	Nozzle Adapter	43	3006965	•	•	Nozzle Adapter
44	3008627	•		Nozzle Oil Tube	44	3008790	•		Nozzle Oil Tube
	3008629		•	Nozzle Oil Tube		3008628		•	Nozzle Oil Tube
45	3008633	•		Regulator Assembly	45	3008846	•		Regulator Assembly
	3008634		•	Regulator Assembly		3008635		•	Regulator Assembly
46	3008630	•		Electrode Assembly	46	3008789	•		Electrode Assembly
	3008631		•	Electrode Assembly		3008632		•	Electrode Assembly
47	3005869	•	•	Electrode Porcelain	47	3005869	•	•	Electrode Porcelain
48	3008623	•		Very Short Air Tube	48	3008788	•		Air Tube
	3008626		•	Very Short Air Tube		3008625		•	Air Tube
<b>SHORT 6" COMBUSTION HEAD</b>					<b>10" COMBUSTION HEAD</b>				
40	3948873	•		Combustion Head	40	3948874	•		Combustion Head
	3948973		•	Combustion Head		3948974		•	Combustion Head
41	3006968	•		Turbulator Disc	41	3006968	•		Turbulator Disc
	3006977		•	Turbulator Disc		3006977		•	Turbulator Disc
42	3006966	•	•	Electrode Support	42	3006966	•	•	Electrode Support
43	3006965	•	•	Nozzle Adapter	43	3006965	•	•	Nozzle Adapter
44	3006969	•		Nozzle Oil Tube	44	3006970	•		Nozzle Oil Tube
	3006973		•	Nozzle Oil Tube		3006974		•	Nozzle Oil Tube
45	3006324	•		Regulator Assembly	45	3005867	•		Regulator Assembly
	3006323		•	Regulator Assembly		3005878		•	Regulator Assembly
46	3006330	•		Electrode Assembly	46	3005870	•		Electrode Assembly
	3006329		•	Electrode Assembly		3005880		•	Electrode Assembly
47	3005869	•	•	Electrode Porcelain	47	3005869	•	•	Electrode Porcelain
48	3007592	•		Short Air Tube	48	3007593	•		Long Air Tube
	3007594		•	Short Air Tube		3007595		•	Long Air Tube

---

---

## **PRECAUTIONS**

---

---

### **AIR FOR COMBUSTION**

Do not install burner in room with insufficient air for combustion. Be sure there is an adequate air supply for combustion if the boiler/furnace room is enclosed. It may be necessary to create a window to permit sufficient air to enter the boiler/furnace room. The installer must follow local ordinances in this regard.

CANADA: It is suggested that the installer follow CSA standard B139.

USA: It is suggested that the installer follow NFPA manual #31.

### **CHIMNEY**

Be sure chimney is sufficient to handle the exhaust gases. It is recommended that only the burner be connected to the chimney. Be sure that it is clean and clear of obstructions.

### **OIL FILTER**

An external oil filter is REQUIRED, even though there is an internal strainer in the pump. The filter should be replaced at least once a year, and the filter container should be thoroughly cleaned prior to installing a new filter cartridge.

### **DRAFT**

Follow the instructions furnished with the heating appliance.

The pressure in the combustion area should be kept as close to zero as possible. The burner will operate with a slight draft or pressure in the chamber.

### **ELECTRICAL CONNECTIONS**

#### **CANADA**

All electrical connections should be done in accordance with the C.E.C. Part 1, and all local codes. The system should be grounded.

#### **USA**

All electrical connections should be done in accordance with the National Electrical Code, and all local ordinances. The system should be grounded.

### **CONTROL BURNER OPERATION**

Check out the burner and explain its operation to the homeowner. Be sure to leave the Owner's Instruction sheet with the homeowner.

### **FIRE EXTINGUISHER**

If required by local codes, install an approved fire extinguisher.

### **ELECTRICAL CONNECTIONS**

. In most localities, a number 14 wire should be used inside a metal conduit. The system should be grounded. A service switch should be placed close to the burner on a fireproof wall in an easily accessible location.



---

**RIELLO BURNERS NORTH AMERICA**

35 Pond Park Road  
Hingham, MA 02043

Phone 781-749-8292  
Toll Free 800-992-7637  
Fax 781-740-2069

**1-800-4-RIELLO**

1-800-474-3556  
[www.riello-burners.com](http://www.riello-burners.com)

2165 Meadowpine Blvd  
Mississauga, ON L5N 6H6

Phone 905-542-0303  
Toll Free 800-387-3898  
Fax 905-542-1525