



MODEL 3200

Temp Limit / LWCO Control with Thermal Targeting™ for Water Boilers

120 VAC Input / 24 VAC Burner Circuit

PATENT PENDING

INSTALLATION INSTRUCTIONS and OPERATING MANUAL

- **Saves Fuel** – Features Thermal Targeting™ technology and Thermal Pre-Purge capability
- **Universal Design** – Replaces common cold-start and triple-action Aquastats*
- **Easy to Install** – Industry standard wiring, dial-type settings, no external sensors
- **Operating Indicators** – LEDs, Dynamic Display and Test Button provide continual and on-demand status checks
- **Prioritizes Hot Water** – Gives priority to low limit setting or to calls from indirect water heater
- **Reduces Condensation** – Holds circulator off until boiler reaches 120°F

*Aquastat is a registered trademark of Honeywell International, Inc.

Three Function Design

Temperature Limit Control

Designed for cold start and tankless coil boilers.

Low Water Cut-Off

Provides protection against potentially dangerous low water conditions when installed with the Hydrolevel Electro-Well™ (see page 2 for details).

Boiler Reset Control

Utilizes *Thermal Targeting™* technology to conserve fuel by monitoring heating demand and establishing target boiler temperatures below the high limit setting (see page 4 for details).



WARNING **Electrical shock hazard.** To prevent electrical shock, death or equipment damage, disconnect power supply before installing or servicing control. Only qualified personnel may install or service this control in accordance with local codes and ordinances. Read instructions completely before proceeding.



CAUTION To prevent serious burns, boiler should be thoroughly cooled before installing or servicing control.

**HYDROLEVEL
COMPANY**

83 Water Street • New Haven, CT 06511 • Phone (203) 776-0473 • FAX (203) 773-1019 • www.hydrolevel.com

IMMERSION WELLS

Fuel Smart HydroStat can be installed on an existing immersion well already in the boiler or on a Hydrolevel Electro-Well™ (sold separately). The low water cut-off function is automatically activated when installed on an Electro-Well™.

IMPORTANT: The control will not provide low water cut-off protection when installed on a standard immersion well.

NOTE: Do not use heat-conducting grease.

Fuel Smart HydroStat installed with Hydrolevel Electro-Well™

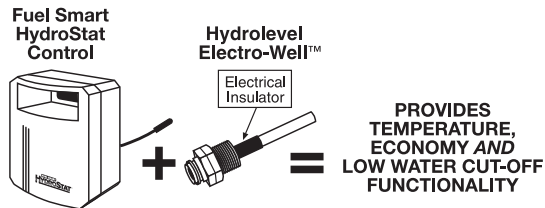

IMPORTANT: For proper operation of the low water cut-off function, there must be a minimum of 1/2" clearance between the copper well tube and any surface within the boiler.

See Electro-Well models on page 8.

Fuel Smart HydroStat installed with standard immersion well

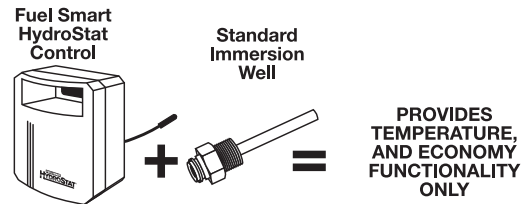

NOTE: When installed on a standard immersion well, the "LWCO Active" LED will not illuminate.

MOUNTING THE CONTROL

IMPORTANT Make sure that the immersion well or Electro-Well™ is installed in the boiler manufacturer's designated temperature limit control tapping.

NOTE: If installing an Electro-Well, pipe sealing compound should be used. Teflon tape is not recommended.

STEP 1 Two mounting positions are available on the back of the control (Fig. 1). Select which of the two positions (2 knockouts) is best for the location of the control. Remove the knockout.

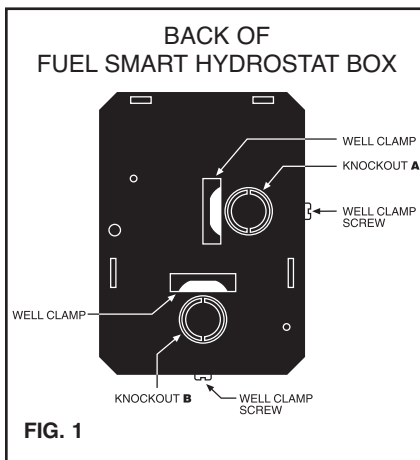

STEP 2 Place control on the well. While holding box against well nut, tighten well clamp screw. (Fig. 2)

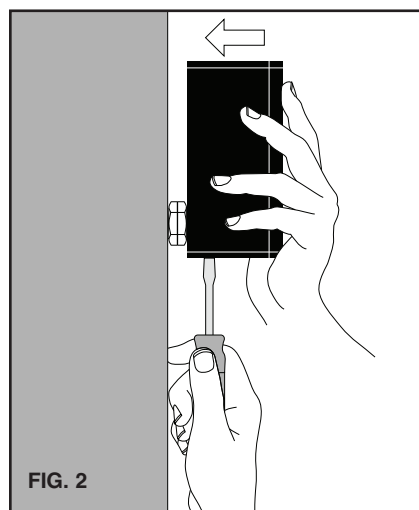

STEP 3 Insert sensor ALL THE WAY into well through the knockout (A or B) you have chosen. (Fig. 3)

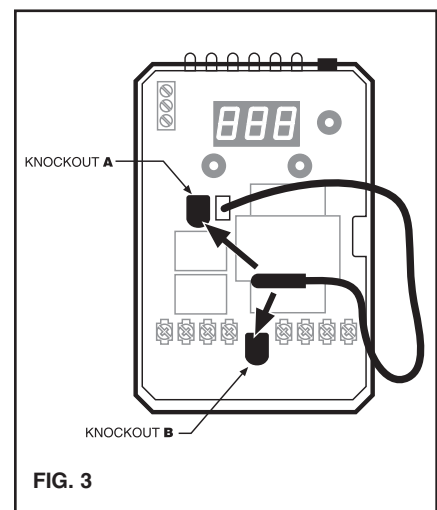

NOTE: In the case of space restrictions, the Fuel Smart HydroStat control may be mounted in a horizontal orientation without any loss of function. Hydrolevel recommends vertical mounting, when possible, for proper orientation of LED display.

REMOTE MOUNTING KITS are available separately for mounting the Fuel Smart HydroStat control box in a remote location. Each kit includes mounting hardware and a remote sensor. See page 8 for kit options.

WIRING

WARNING Electrical shock hazard. To prevent electrical shock, death or equipment damage, disconnect power supply before installing or servicing this control.

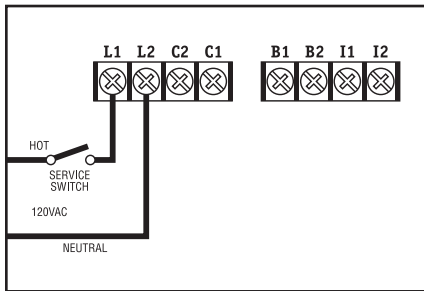

STEP 1 Connect 120 VAC Hot to terminal **L1**. Connect 120 VAC Neutral to terminal **L2**. Disconnect means and overload protection as required (provided by others).

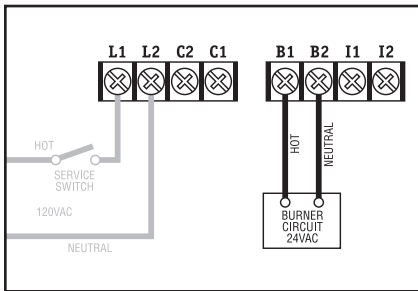

STEP 2 Connect the burner circuit to **B1-B2**. (B2 is neutral.)

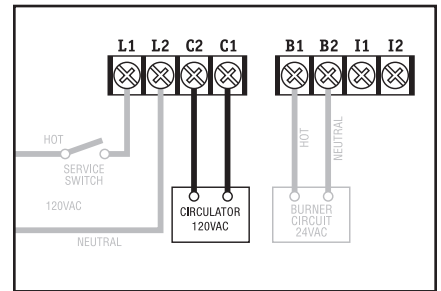

STEP 3 Connect the circulator to **C1-C2**. (C2 is neutral.)

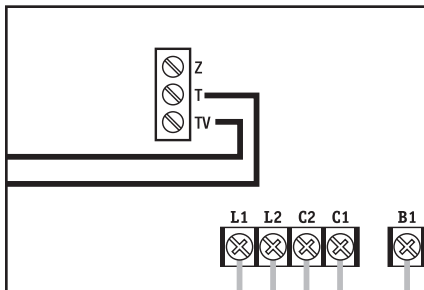

STEP 4 Connect the thermostat to **T-TV**.

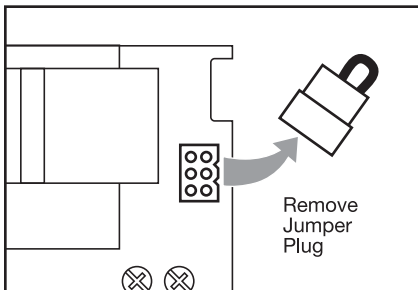

STEP 5 If the boiler is equipped with a plug-in style vent damper, unplug the factory installed jumper from the receptacle on the circuit board and replace it with the vent damper plug.
NOTE: Once a vent damper plug is connected to the HydroStat, the control is permanently altered and will no longer function when the vent damper plug is disconnected.

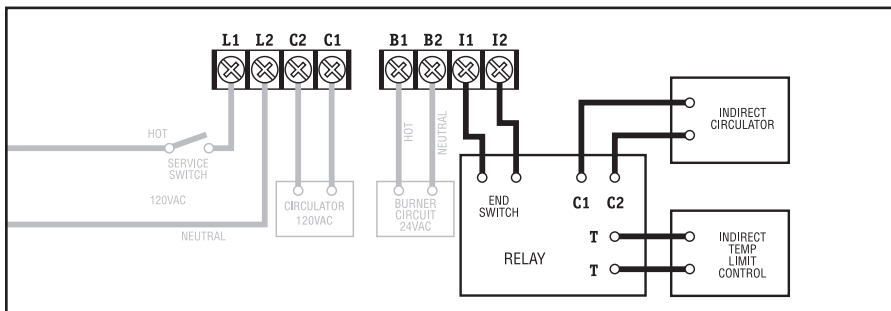

STEP 6 For Systems with Indirect Water Heaters

When installing with an indirect water heater, the signal from the indirect must be separated from the heating zone signals and wired to **I1** and **I2** as shown above. Calls to **I1** and **I2** will bypass the Thermal Targeting feature and allow the boiler to fire to the high limit setting to heat the indirect tank.

NOTE: If you choose not to separate the indirect signal from the heating zones, the Economy Feature should be turned OFF to insure that the boiler supplies adequate temperature to heat the indirect tank (see page 4).

ZONE VALVE WIRING

IMPORTANT: Use a separate transformer to power zone valves. Connecting zone valves to Z-TV may overload the HydroStat and cause a lock-out condition (see *Troubleshooting* on page 6 for more information). The total load, including the burner circuit, vent damper, and Z-TV connections must not exceed 1.2 amps (30 VA). Connect zone valve end-switch to T-TV as shown below.

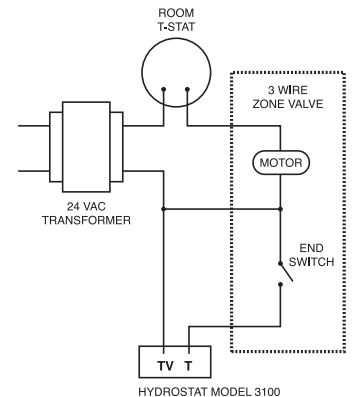

3 WIRE ZONE VALVE

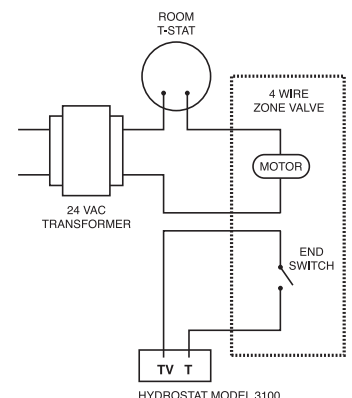

4 WIRE ZONE VALVE

SETTING THE CONTROL

NOTE: Settings can be checked using the TEST/SETTINGS Button. See page 5 for details.

Setting the High Limit

The high limit is factory set at 190°F. To adjust, turn the HI TEMP Dial **A** until the desired setting is displayed. (Setting range: 100°-220°F)

Setting the Low Limit

The low limit is designed to maintain temperature in boilers equipped with tankless coils used for domestic hot water. The low limit is factory set to OFF. Prior to adjusting, remove the jumper (not equipped on all units) **B**. Then turn the LO TEMP Dial **C** clockwise until the desired temperature is displayed. For proper operation, the low temperature limit setting should be at least 10° below the high limit setting. **NOTE:** For cold start operation, the low limit must be turned OFF. **IMPORTANT:** If low limit temperature cannot be set above 140°F, remove jumper **B**. (Setting range: OFF or 110°-200°F).

Setting the Economy Feature

The Economy Feature is factory set for a 1 zone heating system. To adjust, turn the ECONOMY Dial **D** until the number displayed equals the number of heating zones. **Do not include indirect water heaters in the number of heating zones.** The Economy Feature conserves fuel by reducing boiler temperature (see “How Thermal Targeting Works” below). If the heating system is unable to supply needed heat to the house, the ECONOMY Dial should be turned to a lower setting (example: In a three zone house, turn the dial to 2 or 1). Conversely, if the boiler provides adequate heat, added fuel savings can be achieved by selecting a higher setting (example: 4 or 5). If the heating and indirect water heater signals were not separated when wiring the control, the Economy

Feature should be turned OFF to insure the boiler supplies adequate temperature to heat the indirect tank.

SETTING	
OFF	Disables economy function. Will allow boiler to fire until hi-limit temp is reached and re-fire with a 10° subtractive differential.
LO	Provides lowest level of fuel savings. Use this setting only if the house does not stay warm at higher settings.
1	Recommended setting for single zone systems
2	Recommended setting for Two zone systems
3	Recommended setting for Three zone systems
4	Recommended setting for Four zone systems
5	Recommended setting for Five zone systems
HI	Provides highest level of fuel savings

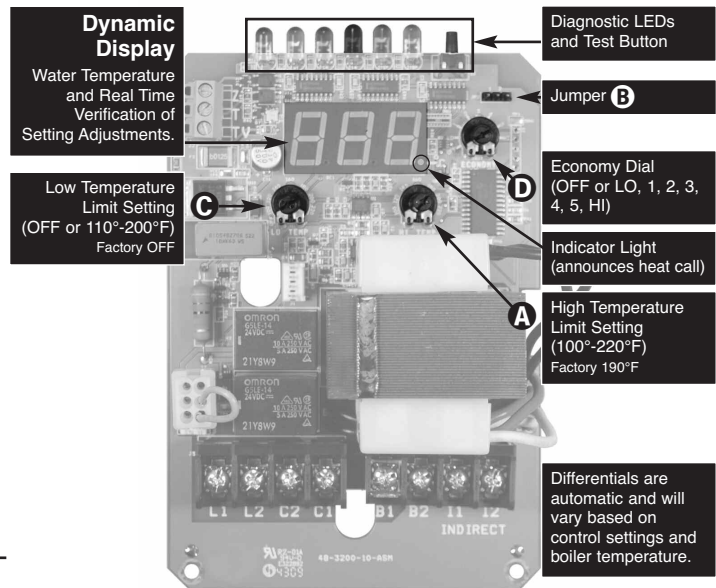

Activating Thermal Pre-Purge (optional)

NOTE: Activation of this feature is not recommended for boilers with tankless coils.

Fuel Smart HydroStat has a Thermal Pre-Purge feature to maximize efficiency. When activated, the control will purge higher boiler temperatures down to 135° at the start of any thermostat call and supply the latent energy in the boiler to the heating zone that is calling. During the purge cycle, the display will indicate **Pur**. If the heat is not sufficient to satisfy the thermostat, the control will energize the burner. This feature works with single- and multi-zone heating systems utilizing circulators or zone valves. No change in wiring is needed.

To Activate Thermal Pre-Purge

Push and hold the TEST/SETTINGS button for 20 seconds. The display will read **Pur On**. To deactivate the feature, push and hold the button a second time for 20 seconds. The display will read **Pur OFF**.

SYSTEM START-UP

At initial start up, with the Economy Feature active, the control establishes a 145°F target temperature. To test the high limit shut-off function, the Economy Dial must be turned to OFF. Once tested, restore the Economy setting. If the heating demand is high, the target will increase over time to satisfy the heat load. **NOTE:** To reduce the potential for condensing, the control will allow the boiler to heat to 120°F prior to energizing the circulator.

HOW THERMAL TARGETING WORKS

Thermal Targeting technology analyzes thermostat activity and continually evaluate how much heat the house requires. When it is very cold outside, the heat demand is high and the Fuel Smart HydroStat will raise the boiler's Target temperature to provide needed heat to the home. When the outside temperature is milder, the heat demand is lower. During these periods, the Fuel Smart HydroStat will lower the boiler's Target temperature – saving fuel – while continuing to provide comfort to the house.

LED LEGEND and TEST/SETTINGS BUTTON

1 TEMP ACTIVE Indicates that the Fuel Smart HydroStat control is powered and that the temperature function is active.

2 TEMP HIGH TEMP Illuminates when the boiler water temperature reaches the high limit setting. It will remain lit until the water temperature falls 10° (see High Limit Differential on page 4). The Fuel Smart HydroStat prevents burner operation while this LED is on.

3 LWCO ACTIVE Indicates that the low water cut-off (LWCO) function of the Fuel Smart HydroStat is active. When the control is installed with a Hydrolevel Electro-Well, this LED will be on at all times when the control is powered. **IMPORTANT:** If the control is installed with a well other than the Electro-Well, this LED will not illuminate indicating that the control is not providing low water cut-off functionality.

4 LWCO LOW WATER Illuminates if the boiler is in a low water condition. The Fuel Smart HydroStat will prevent burner operation during this condition. **IMPORTANT:** The system must be checked by a qualified heating professional prior to resuming operation. **WARNING: DO NOT ADD WATER UNTIL THE BOILER HAS FULLY COOLED.**

5 ECONOMY ACTIVE Indicates that the Thermal Targeting function is active and the Fuel Smart HydroStat will reduce boiler temperature to conserve fuel. The Economy feature is activated using the ECONOMY dial. (See "How Thermal Targeting Works" on page 4 for more information).

6 ECONOMY TARGET When the Economy feature is active, the Fuel Smart HydroStat continually sets target temperatures below the high limit setting to maximize fuel efficiency. When the boiler water reaches the target

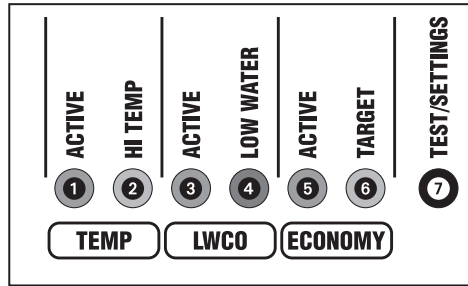

temperature, the LED illuminates and the burner will shut down. The boiler water will continue to circulate and heat the house as long as the thermostat call continues. The LED will stay lit until the boiler temperature drops to the differential set point (see Target Temp Differential on page 4) at which point the boiler

will be allowed to fire again. **NOTE:** This LED illuminates regularly during normal boiler operation.

7 TEST/SETTINGS Button

To Test Low Water Cut-Off: Press and hold the Test/Settings button for 5 seconds. The display will read LCO.

LWCO TEST LCO

The red Low Water light should illuminate and the burner circuit (B1 and B2) should de-energize. **NOTE:** The control must be installed with a Hydrolevel Electro-Well for low water cut-off functionality (see page 2 for more details).

To View Current Settings: Press and release the Test/Settings Button in short intervals to sequentially display the following settings:

HIGH LIMIT SETTING HL
 LOW LIMIT SETTING LL
 ECONOMY SETTING ECO
 CURRENT TARGET TEMPERATURE 000
 PRE-PURGE SETTING Pur

The display will return to boiler temperature (default) if Test/Settings Button is not pressed for 5 seconds.

TROUBLESHOOTING

Burner Will Not Fire	See Flow Chart 1, page 6
Burner Will Not Shut Down	See Flow Chart 2, page 7
Temperature Display Exceeds High Limit Setting	Under normal operation, boiler temperature will continue to rise after the control shuts off the burner. This condition, known as "thermal stacking", results from hot boiler surfaces continuing to release heat into the boiler water.
No or Insufficient Domestic Hot Water	For boilers equipped with a tankless coil, make sure the low limit setting on the HydroStat is set properly. NOTE: If the low limit setting is dialed fully counter clockwise, it will shut off the low temperature maintenance feature and will function as a cold start control. If installed with an indirect water heater, insure that the end switch in the relay box controlling the indirect water heater is connected to the I1-I2 terminals. This will insure that the domestic water calls are prioritized. (see "Heating-With Indirect Water Heater" on page 3).
Boiler Will Not Maintain Low Limit Temperature	Check for overlapping high temperature setting. If the high limit setting is set below the low limit setting, the control will default to the high limit setting and the corresponding high limit differential setting.
House Will Not Get or Stay Warm	1. Check for air-bound radiators. 2. Check thermostat settings including heat anticipator settings (common on non-digital thermostats). 3. Check the Economy setting. The Economy feature, much like outdoor reset controls, lowers average boiler temperature and can slow or, in some cases, prevent the house from coming up to temperature. Move to a lower setting (see "Setting the Economy Feature" on page 4).

Troubleshooting Flow Chart 1 – Burner Will Not Fire

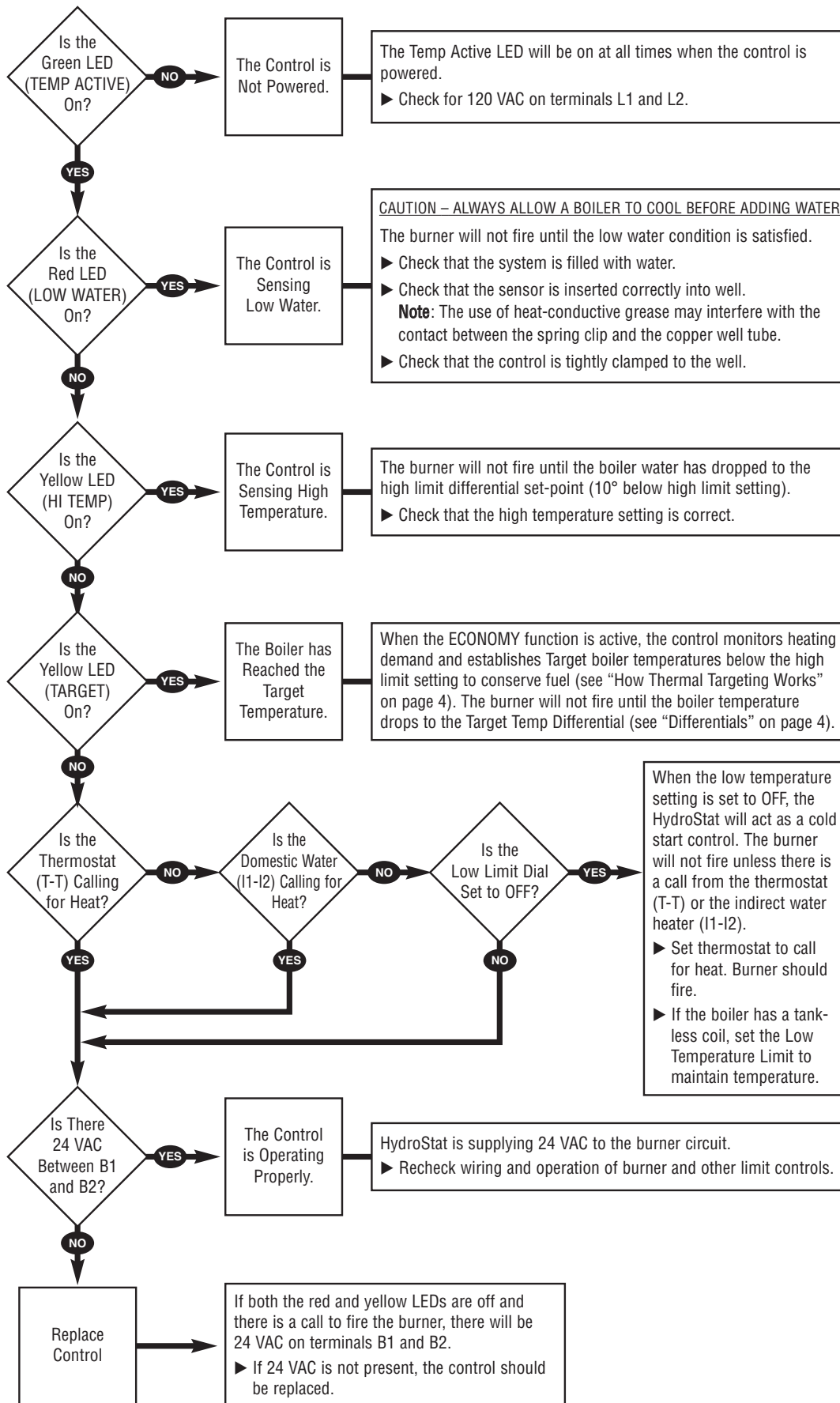

Troubleshooting Flow Chart 2 – Burner Will Not Shut Down

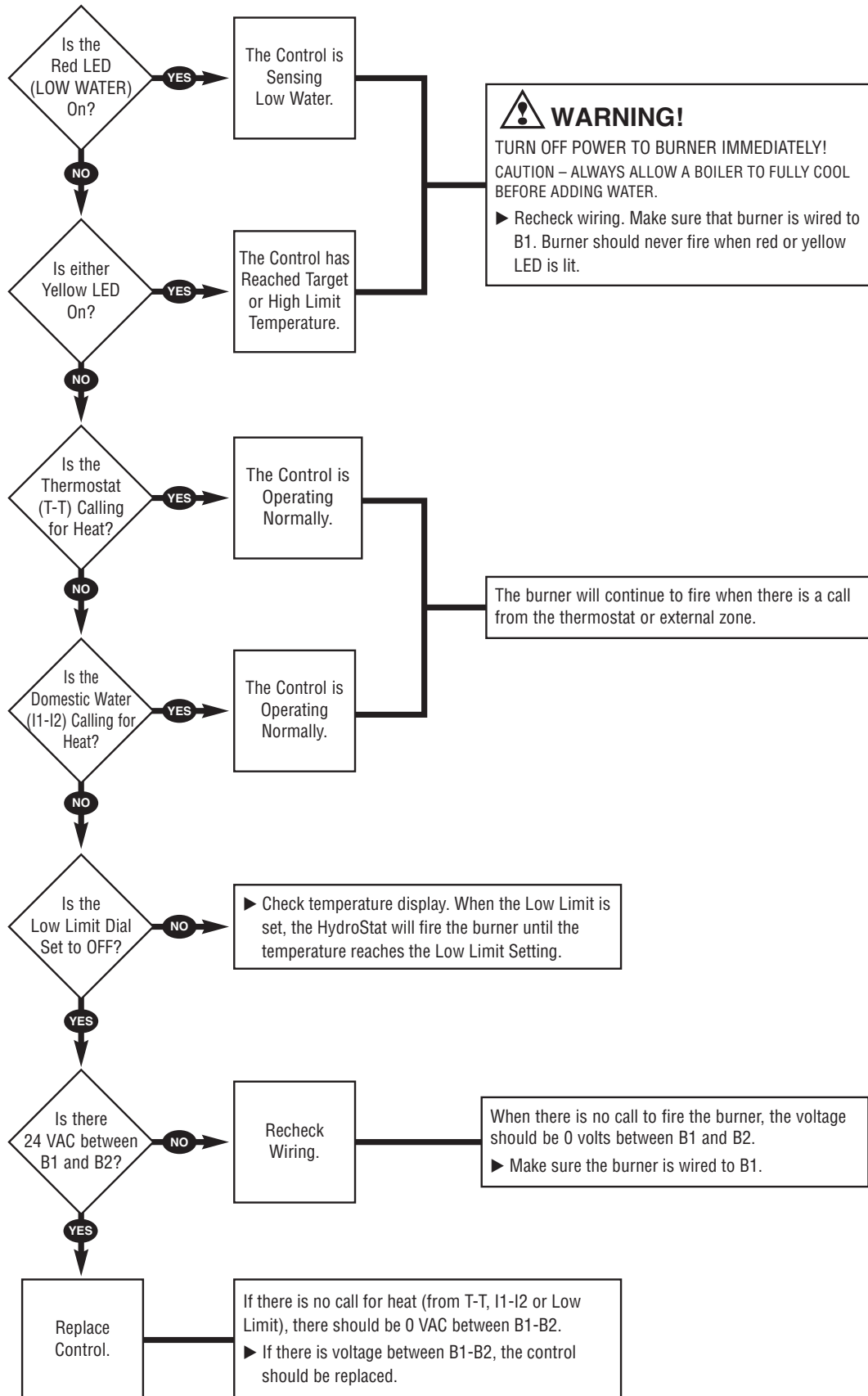

MAINTENANCE

Remove the Electro-Well from the heating system every five years and clean any scale or sediment deposits from all parts that are exposed to the boiler water. After cleaning, reinstall the well using pipe sealing compound. **Teflon tape is not recommended.**

REMOTE MOUNTING KITS

Part No.	Description	Part No.	Description
48-101	HydroStat Remote Mount Kit with 24" sensor	48-103	HydroStat Remote Mount Kit with 10' sensor
48-102	HydroStat Remote Mount Kit with 48" sensor	48-104	HydroStat Remote Mount Kit with 20' sensor

ELECTRO-WELLS

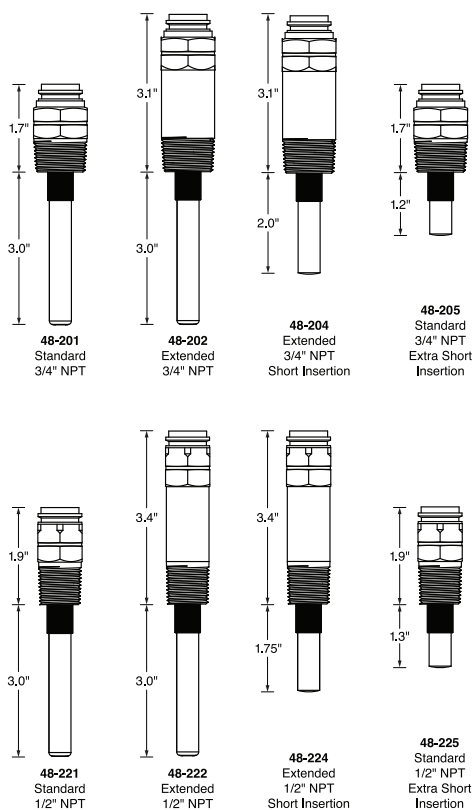

DIMENSIONS

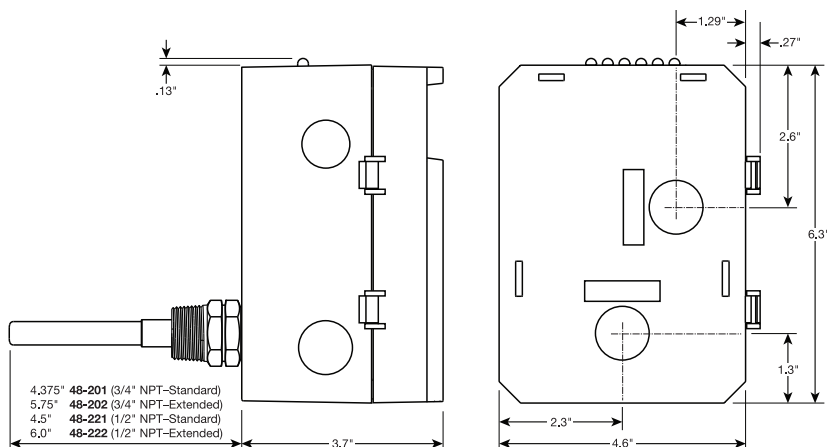

SPECIFICATIONS FUEL SMART HYDROSTAT MODEL 3200

Input voltage	120 VAC, 60 HZ
Burner contacts	30 VA@24 VAC
Circulator contacts	5.8 FLA, 34.8 LRA@120 VAC
Operating range – low limit	Off or 110°F - 200°F
Operating range – high limit	100°F - 220°F



LIMITED MANUFACTURER'S WARRANTY

We warrant products manufactured by Hydrolevel Company to be free from defects in material and workmanship for a period of two years from the date of manufacture or one year from the date of installation, whichever occurs first. In the event of any claim under this warranty or otherwise with respect to our products which is made within such period, we will, at our option, repair or replace such products or refund the purchase price paid to us by you for such products. In no event shall Hydrolevel Company

be liable for any other loss or damage, whether direct, indirect, incidental or consequential. This warranty is your EXCLUSIVE remedy and shall be IN PLACE OF any other warranty or guarantee, express or implied, including, without limitation, any warranty of MERCHANTABILITY or fitness for a particular purpose. This warranty may not be assigned or transferred and any unauthorized transfer or assignment thereof shall be void and of no force or effect.