

### Installation Instructions

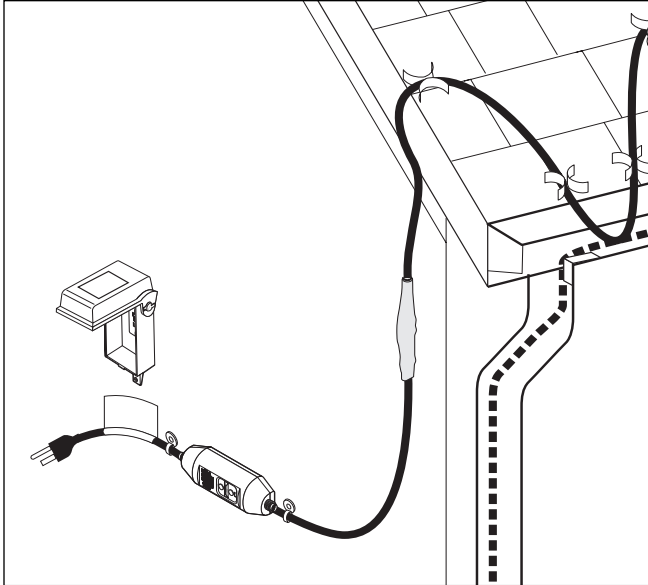

#### Description

The Raychem® H908 is a plug-in, ground-fault-protected power connection kit for use with WinterGard® H311, WinterGard Plus H611, and WinterGard Wet H612 120 V heating cables.

This kit ensures compliance with Tyco Thermal Controls, NEC and CEC requirements for ground-fault protection of equipment. It does not protect people against the hazards of shock. The kit includes materials for one power connection and end seal. All WinterGard, WinterGard Plus, and WinterGard Wet heating cables are designed for water-pipe freeze protection applications. Only the H612 heating cable can be used for both pipe freeze protection and roof and gutter de-icing applications.

For additional technical support call Tyco Thermal Controls at (800) 542-8936.

#### Tools Required

- Needle nose pliers
- Utility knife
- Diagonal cutters
- Propane torch or heat gun
- Panduit crimp tools CT100 and CT570

#### Additional Materials Required

- Grounded, UL Listed 15-amp, 120-volt receptacle (receptacle must be approved for wet locations if exposed to weather)
- Additional cable ties may be required for roof and gutter applications.
- Your application may require additional Raychem accessories; for example, H903 application tape for pipe applications; H913/H914 roof clips and/or H915 downspout hangers for roof and gutter de-icing applications.

#### Approvals



Pipe Heating Cable  
718 K  
Also Listed as De-icing and Snow Melting  
Equipment



Desig.  
2E, 3A, 3B, 3C, 3D

#### Kit Contents

Item	Qty	Description
A	1	Plug-in ground-fault equipment protection device
B	2	Black cloth tapes (6" long x 1" wide)
C	1	Uninsulated braid crimp
D	2	Insulated bus wire crimps
E	2	Heat-shrinkable tubes (1" long x 1/8" dia.)
F	2	Clamp ties
G	1	Heat-shrinkable tube (8" long x 1" dia.)
H	2	Warning labels for pipe-trace applications
I	2	De-icing and snow melting equipment labels
J	2	Mastic strips (2" long x 1" wide)
K	1	Gel-filled end seal
L	1	Heat-shrinkable tube (5" long x 3/4" dia.)

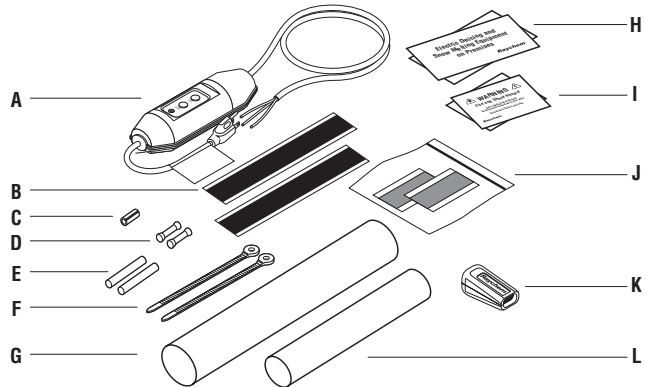

#### ⚠ WARNING:

These components are electrical devices. They must be installed correctly to ensure proper operation and to prevent shock or fire. Carefully follow all of the installation instructions and read these important warnings.

- To minimize the danger of fire from sustained electrical arcing if the heating cable is damaged or improperly installed, and to comply with the requirements of Tyco Thermal Controls and the national electrical codes, ground-fault equipment protection must be used on each heating cable branch circuit. Arcing may not be stopped by conventional circuit protection.
- Component approvals and performance are based on the use of specified parts only. Do not substitute parts or use vinyl electrical tape.
- The black heating-cable core is conductive and can short. It must be properly insulated and kept dry.

- Keep components and heating cable ends dry before and during installation.
- Damaged bus wires can overheat or short. Do not break braid or bus wire strands when scoring the jacket or core.
- Bus wires will short if they contact each other. Keep bus wires separated.
- Heat-damaged components can short. Use a heat gun or a torch with a soft, yellow, low-heat flame, not a blue focused flame. Keep the flame moving to avoid overheating, blistering, or charring the heat-shrinkable tubes. Avoid heating other components. Replace any damaged parts.
- Use only fire-resistant insulation materials such as fiberglass wrap.
- Leave these installation instructions with the user for future reference.

#### ⚠ CAUTION:

Charring or burning the heat-shrinkable tubes in this kit will produce fumes that may cause eye, skin, nose, and throat irritation. Consult Material Safety Data Sheet RAY/3122.

24-hour emergency telephone:  
CHEMTREC (800) 424-9300.

Non-emergency health and safety information:  
(650) 361-4907.

# H908 Design and Installation Information for Heating Cable on Pipes Only

(WinterGard H311, WinterGard Plus H611, and WinterGard Wet H612 Heating Cables)

## Electrical codes

Articles 422 and 427 of the National Electrical Code (NEC) and Part I, Section 62 of the Canadian Electrical Code (CEC), govern the installation of Raychem heating cable for pipe freeze protection.

**Important:** For the Tyco Thermal Controls warranty to be valid, you must comply with all the requirements outlined in these guidelines.

All thermal and design information provided here is based upon a “standard” installation with heating cable fastened to an insulated pipe. For any other application or method of installation, consult Tyco Thermal Controls at (800) 542-8936.

## Heating cable selection and design

Make sure that the heating cable being used is suitable for your application. Refer to the Raychem Commercial and Residential Products Application and Design Guide (H53585) for heating cable application information.

### 1. Determine the heating cable type.

Use Table 1 to select heating cables for insulated *metal* pipes. Use Table 2 to select heating cables for insulated *plastic* pipes. Read across the table to find your pipe size, then drop down to the line corresponding to the lowest air temperature for that application and the correct insulation thickness. The cell at that intersection has a particular shading and may have a number. The shading indicates which heating cable to use (key to the shading appears above the table headings). A number represents the spiraling ratio (feet of heating cable per foot of pipe).

If no number appears in the cell, straight trace the pipe. If a number does appear in the cell, spiral trace the pipe.

If your spiraling ratio is 2.0, multiple trace the pipe using two straight traces at the 4 o'clock and 8 o'clock positions.

If your spiraling ratio is 3.0, multiple trace the pipe using three straight traces at the 11 o'clock or 1 o'clock position, **and** at the 4 o'clock and 8 o'clock positions.

#### Example 1:

Pipe size: 1"  
 Lowest air temp.: 0°F  
 Insul. thickness: 1/2"

Metal pipe:  WinterGard H311

Plastic pipe:  WinterGard Plus H611 or WinterGard Wet H612

#### Example 2:

Pipe size: 2 1/2"  
 Lowest air temp.: -20°F  
 Insul. thickness: 1/2"



Metal pipe:  1.3 WinterGard Plus H611 or WinterGard Wet H612

(Use 1.3 feet of heating cable per foot of pipe.)

Plastic pipe:  2.0 WinterGard Plus H611 or WinterGard Wet H612



(Use two straight traces at the 4 o'clock and 8 o'clock positions.)

**Table 1. For METAL pipes with fiberglass insulation or equivalent (based on 40°F maintain temperature, 10% safety factor)**

**Key to Table 1:**  = H311  = H611, H612, H621, H622  = Use a thicker insulation

Lowest air temp. (°F)	Insulation thickness	Nominal pipe size										
		1/2"	3/4"	1"	1 1/4"	1 1/2"	2"	2 1/2"	3"	4"	6"	8"
0	1/2"									1.3	1.8	3.0
	1"											1.3
	1 1/2"											
-20	1/2"						1.1	1.3	1.5	1.8	3.0	
	1"									1.1	1.5	1.9
	1 1/2"										1.1	1.3
-40	2"											
	1/2"				1.1	1.2	1.4	1.7	2.0	3.0		
	1"								1.1	1.4	1.9	3.0
	1 1/2"										1.4	1.7
	2"									1.1	1.4	

**Table 2. For PLASTIC pipes with fiberglass insulation or equivalent (based on 40°F maintain temperature, 10% safety factor)**

**Key to Table 2:**  = H311  = H611, H612, H621, H622  = Use a thicker insulation

Lowest air temp. (°F)	Insulation thickness	Nominal pipe size										
		1/2"	3/4"	1"	1 1/4"	1 1/2"	2"	2 1/2"	3"	4"	6"	8"
0	1/2"						1.2	1.4	1.7	2.0	3.0	
	1"									1.2	1.6	2.0
	1 1/2"										1.2	1.5
-20	1/2"			1.1	1.3	1.5	1.8	2.0	3.0			
	1"						1.1	1.2	1.4	1.8	3.0	
	1 1/2"								1.1	1.3	1.7	3.0
	2"										1.4	1.7
-40	1/2"	1.1	1.1	1.5	1.8	2.0	3.0	3.0				
	1"				1.1	1.2	1.4	1.6	1.9	3.0		
	1 1/2"						1.1	1.2	1.4	1.7	3.0	3.0
	2"								1.1	1.3	1.8	3.0

## H908 Design and Installation Information for Heating Cable on Pipes Only (continued)

(WinterGard H311, WinterGard Plus H611, and WinterGard Wet H612 Heating Cables)

### 2. Calculate the total heating cable length

Pipe length  $\times$  spiraling ratio  
 + 4 ft  $\times$  # gate/globe valves  $\times$  valve length (ft)  $\times$  spiraling ratio  
 + 2 ft  $\times$  # ball/butterfly valves  $\times$  valve length (ft)  $\times$  spiraling ratio  
 + 2 ft  $\times$  # flanges  $\times$  (pipe diameter / 12)  $\times$  spiraling ratio  
 + 2 ft  $\times$  # pipe supports  $\times$  (pipe diameter / 12)  $\times$  spiraling ratio  
 + 1 ft for each power connection  
 + 2 ft for each splice connection  
 + 3 ft for each tee connection

---

= Total heating cable length (ft)

### 3. Determine the maximum heating cable circuit length allowed

See Table 3 on the next page. Ensure that your circuits do not exceed the maximum circuit length listed in Table 3. If necessary, use additional shorter circuits.

**Example** (taken from Example 2 [on metal pipe], pg. 2):

Pipe length:	50 ft
Spiral ratio:	1.3 (from Table 1, pg. 2)
Globe valves:	3 (each 0.5 ft long)
Pipe supports:	10 supports for 1" pipe
Power connections:	1
Splice connections:	1
End Seals:	1

**WinterGard heating cable required:**

Pipe length $\times$ spiral ratio	= 50 ft $\times$ 1.3	= 65.0 ft
3 globe valves (.5 ft each)	= 4 ft $\times$ 3 $\times$ .5 $\times$ 1.3	= 7.8 ft
10 pipe supports	= 2 ft $\times$ 10 $\times$ (1 / 12) $\times$ 1.3	= 2.2 ft
1 power connection	= 1 ft $\times$ 1	= 1.0 ft
1 splice connection	= 2 ft $\times$ 1	= 2.0 ft
1 end seal	= 0.5 ft $\times$ 1	= 0.5 ft

Total heating cable length required = 78.5 ft

## Heating cable installation

### 1. Prepare for installation

- Store the heating cable in a clean, dry place.
- Complete piping pressure test.
- Review the heating cable design and compare to materials received to verify that the proper Raychem heating cable and accessories are available. The heating cable will have the heating cable type printed on the outer jacket.
- Walk the system and plan the routing of the WinterGard heating cable on the pipe.

### 2. Cut the heating cable to length

- Cut the heating cable to the length required. This can be done before or after the cable is attached to the pipe. Leave a minimum of 1 foot extra heating cable for connection to power. For splice and tee connections, leave a minimum of 1 foot for each section of heating cable. Raychem heating cable can be cut to length without affecting its heat output per foot.
- Protect the heating cable ends from moisture or mechanical damage if they will be left exposed before connection.

### 3. Position and attach heating cable to pipe

- Be sure all piping to be traced is dry.
- Install heating cable, using straight tracing, spiraling, or multiple tracing according to the "Heating cable selection and design" section on page 2.
- For straight tracing, install the heating cable on a lower half of the pipe; for example, in the 4 o'clock or 8 o'clock position.
- Be sure to install the additional heating cable required for valves, flanges, etc. as indicated in Step 2 of the "Heating cable selection and design" section.
- When the design calls for spiraling, begin by suspending a loop every 10 feet as shown in Figure 1. To determine the loop length, obtain the spiral factor from Table 1 or 2 and multiply by 10. For example, if

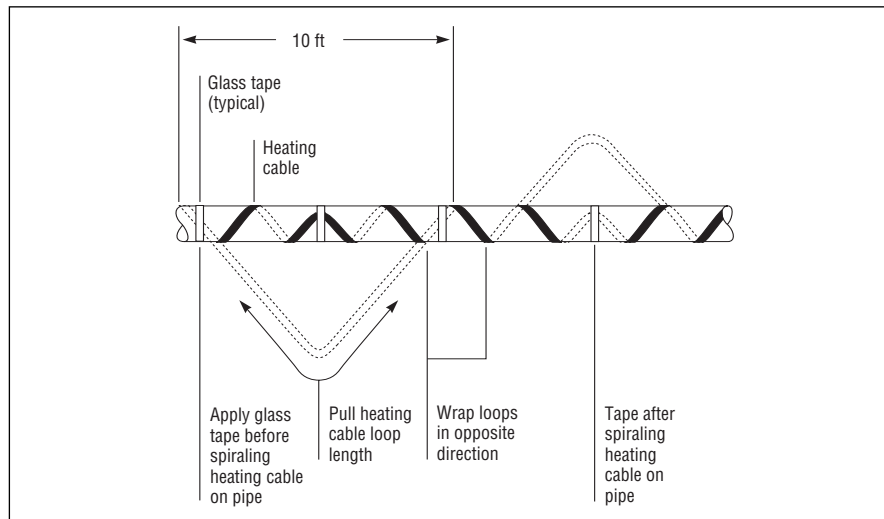

Figure 1. Spiraled heat tracing

a spiral factor of 1.3 is called for, leave a 13-foot loop of heating cable at every 10-foot section of pipe. Grasp the loop in its center and wrap it around the pipe. Even out the distance between spirals by sliding the wraps along the pipe. Use glass tape to secure the center of the loop to the pipe. Secure the heating cable flat to the pipe to obtain good contact.

- Tape the heating cable to the pipe at 2-foot intervals using H903 fiberglass application tape or nylon cable ties. Do not use vinyl electrical tape, duct tape, metal bands, or wire.

### 4. Install heating cable end seals, splices, tees, and power connection.

- Test each circuit before installing the H908 ground-fault device, according to the instructions in the "Heating cable testing and maintenance" section.
- Install all end seals, splices, tees, and power connection prior to plugging in.
- Follow the H908 kit installation instructions beginning on page 8.

- Use only weatherproof receptacles approved for wet locations when installing WinterGard Wet H612 heating cable with the H908 Power Connection Kit for Roof and Gutter De-Icing Applications.

### 5. Check the installation

- Prior to installing thermal insulation, make sure the heating cable is free of mechanical damage (from cuts, clamps, etc.) and thermal damage (from solder, overheating, etc.).
- Visually check all power connections, end seals, splices, and tees.

## H908 Design and Installation Information for Heating Cable on Pipes Only (continued)

(WinterGard H311, WinterGard Plus H611, and WinterGard Wet H612 Heating Cables)

### 6. Install thermal insulation

- A reliable heat-tracing system depends on properly installed and weather-proofed thermal insulation.
- Ensure that type and thickness of the insulation are in accordance with the information in the heating cable selection tables on page 2 and that all pipe work—including valves, joints, wall penetrations, and other elements—has been fully insulated.

- Minimize the potential for mechanical damage to the heating cable after installation by installing the insulation immediately.

### 7. Mark the installation

- Place “Warning” labels for pipe trace applications on the outer surface of the insulation at 10-foot intervals (on alternating sides of the pipe) to indicate the presence of electric heating cable. Additional labels and application tape are contained in the H903 kit.

### 8. Check the installation

- Prior to powering, check to be sure the heating cable is free of mechanical damage (cuts, clamps, etc.).
- Visually check all power connections, end seals, splices, and tees for proper installation.

### 9. Test the ground-fault protection

- Verify the H908 ground-fault device is functioning correctly, according to the instructions in the “Heating cable testing and maintenance” section.

## Electrical protection

For the maximum heating cable circuit length permitted for a given circuit breaker rating, refer to Table 3. Limit your circuit length based on your lowest anticipated start-up temperature.

The H908 kit contains a built-in 27-mA equipment-protection ground-fault device. This kit provides ground-fault protection of equipment only. It does not protect people against the hazards of electrical shock.

Do not use an extension cord. Plug the unit directly into the outlet.

**Note:** Tyco Thermal Controls, Article 427 of the NEC and Part I, Section 62 of the CEC require ground-fault protection for pipe heating cable applications.

**Table 3. Maximum heating cable circuit length\***

Heating cable type	Circuit breaker rating (A)	Maximum circuit length (ft) for minimum start-up temperature	
		40°F	0°F
WinterGard 120 V H311	15	250	150
WinterGard Plus 120 V H611	15	150	125
WinterGard Wet 120 V H612 (on pipe)	15	150	125
WinterGard Wet 120 V H612 (in drains)	15	125	100

**Note:** Circuit breaker sizing is based on Section 427-4 of the National Electrical Code.

\*Maximum circuit lengths are based on start-up load. Steady-state amps per foot is dependent upon heating cable temperature.

## Heating cable testing and maintenance

Using a 2500-Vdc megohmmeter (Megger) test the heating cable circuit prior to installing the H908 ground-fault device but after installing any splices, tees and end seals. Measure the insulation resistance between the heating cable bus wires and the copper braid. If the readings are less than 20 megohms, inspect heating cables for signs of damage and verify the components are correctly installed.

If physical damage is found, the entire damaged section must be removed and a new section of heating cable spliced in using only approved H910 splice kits.

If physical damage cannot be found, the complete circuit should be removed and replaced with new heating cable.

To verify the ground-fault circuit is functioning, test the H908 before each use. Push in the test button. The indicator light must turn off. Then press the reset button. If the light goes back on, the device is ready to use. Do not use the device if the indicator light does not go on when the device is reset or if the indicator light remains on when the test button is pushed.

Test the H908 functionality before each winter season or more often as required by local code.

**⚠ WARNING:** Shock and Fire Hazard Damaged heating cable or components can cause electrical shock, arcing, and fire. Do not attempt to energize damaged cable or components. Replace them immediately using a new length of heating cable and the appropriate accessories.

**Table 4. Product data—WinterGard products on pipe only**

Heating cable type	WinterGard	WinterGard Plus	WinterGard Wet
	H311	H611	H612
Service voltage (V)	120	120	120
Thermal output at 40°F (W/ft)	3	6	6
Weight per 100 ft (lb)	6	6	9
Minimum installation temp. (°F)	0	0	0
Maximum exposure temp. (°F)	150	150	150
Exposure to chemicals	None	None	None
Environment	Use only in ordinary (nonhazardous) areas.	Use only in ordinary (nonhazardous) areas.	Use only in ordinary (nonhazardous) areas.

## H908 Design and Installation Information for Roof and Gutter De-Icing Only

(WinterGard Wet H612 Heating Cable)

### Electrical codes

Article 426 of the National Electrical Code and Part I, Section 62 of the Canadian Electrical Code govern the installation of Raychem heating cable systems for roof and gutter de-icing.

**Important:** For the Tyco Thermal Controls warranty to be valid, you must comply with all the requirements outlined in these guidelines.

All design information provided here is based on a “standard” shake or shingle roof application. For any other roof de-icing installation, refer to the WinterGard Wet Design, Installation and Maintenance manual (H56804) or contact Tyco Thermal Controls at (800) 542-8936.

### Heating cable design

Only WinterGard Wet H612 120 V heating cable is suitable for use with the H908 power connection kit for roof and gutter de-icing applications.

#### 1. Calculate the heating cable length required.

Total heating cable length:

$$\begin{aligned} & \text{Roof edge length (ft)} \times \text{feet of heating cable} \\ & \text{per foot of roof edge} \\ & + 1.5 \times \text{total gutter length (ft)} \\ & + \text{Total downspout length (ft)} \\ & + 1 \text{ ft for each power connection} \\ & + 2 \text{ ft for each splice connection} \\ & + 3 \text{ ft for each tee connection} \\ \hline & = \text{Total heating cable length (ft)} \end{aligned}$$

**Table 5. Typical spacing and layout measurements**

Roof overhang	Tracing width	Tracing height	Length of WinterGard Wet per foot of roof edge
12"	2 ft	18"	2 ft
24"	2 ft	30"	3 ft
36"	2 ft	42"	4 ft

#### Example:

Roof edge:	40 ft
Roof overhang:	1 ft
Roof gutter:	40 ft
Downspout:	15 ft
Power connection:	2 ea
Tee connection:	1 ea

#### WinterGard Wet heating cable required:

Roof edge:	80 ft = 40 × 2 (from table above)
Roof gutter:	60 ft = 40 × 1.5
Downspout:	15 ft
Power connection:	1 ft × 2 ea
Tee connection:	3 ft × 1 ea

Total WinterGard Wet heating cable required: 160 ft\*

\* This total exceeds 125-ft maximum circuit length, therefore two separate circuits are required.

### Heating cable installation

#### 1. Prepare for installation

- Store the heating cable in a clean, dry place.
- Use only the following Raychem accessories to satisfy code and agency requirements:
  - H908 Plug-in Power Connection Kit (with end seal)
  - H910 Splice and Tee Kit (if splicing or teeing)
  - H915 Downspout Hangers
  - H913/H914 Roof Clips
- Carefully plan the routing of the heating cable for roof and gutter de-icing.
- Make certain gutters and downspouts are free of leaves and other debris.

#### 2. Cut the heating cable to length

- Cut the heating cable to the length required before or after it is installed. Leave a minimum of 1 foot extra heating cable for connection to power. For splice and tee connections leave a minimum of 1 foot for each section of heating cable. Raychem heating cable can be cut to length without affecting its heat output per foot.
- Protect the heating cable ends from moisture and mechanical damage if they will be left exposed before connection.

#### 3. Position and attach the heating cable

##### On roofs

- Loop the heating cable on the overhang area of the roof. This is the part that extends past the building wall. Extend the bottom of each heating cable loop over the roof edge and, using a UV-resistant cable tie, connect the bottom of each loop to the cable running in the gutter to ensure a drainage channel off the roof and into the gutter and downspout. The cable running in the gutter should remain against the bottom of the gutter. Extend the top of each heating cable loop beyond where the wall joins the roof. Tyco Thermal Controls recommends 2-foot clip-spacing along the roof edge. See the “Heating cable design” section (Table 5) for spacing and layout information.
- Use H913/H914 roof clips to attach heating cable to the roof surface. One H913 kit contains ten roof clips for approximately 7 linear feet of roof edge. One H914 kit contains 50 roof clips for approximately 35 linear feet of roof edge.
 

For flat roofs, the heating cable can be spaced as needed to create run-off paths for melting ice and snow. Use single-ended clips located at 3-foot intervals to secure the cable to the roof.

Roof clips may be attached to a shake or shingle roof with nails or screws. Roof clips may be attached to a metal roof

using screw, nail or adhesive. (See H56723 installation instruction for more details.)

Reseal the nail or screw holes if necessary before installing heating cable in the clips.

- A barrier (snow fence) can be placed on the roof above the heating cable. This prevents damage to the cable and keeps the installation from coming loose due to ice slides. The heating cable can be attached to the barrier with UV-resistant cable ties, instead of using roof clips, if desired. Do not use wire or other materials because they may damage the heating cable.

##### In gutters and downspouts

- Run heating cable along gutters and into downspouts, ending below the freezing level. Permanent attachment of the cable to the gutter bottom is not necessary. Loop the heating cable in downspouts if convenient, such as when the downspout is not at the end of the run, or use the H910 splice and tee kit to tee down the downspout.
- Use H915 downspout hangers to protect the heating cable from fraying and to provide strain relief. Refer to the H915 kit instructions for installation details.
- Use H913/H914 roof clips to route heating cable into and out of the gutter in such a way as to prevent abrasion to the cable. Protect all cable that protrudes past the lower opening of the downspout.

## H908 Design and Installation Information for Roof and Gutter De-Icing Only (continued)

(WinterGard Wet H612 Heating Cable)

### 4. Install heating cable end seals, splices, tees, and power connection

- Using a megohmmeter, test each circuit before installing the H908 ground-fault device, according to the instructions in the “Heating cable testing and maintenance” section.
- Install all end seals, splices, tees, and power connection prior to plugging in.
- Follow the H908 kit installation instructions beginning on page 8.
- Use only weatherproof receptacles approved for wet locations when installing WinterGard Wet H612 heating cable with the H908 Power Connection Kit for Roof and Gutter De-Icing Applications.

### 5. Mark the installation

- Two labels indicating the presence of electric de-icing and snow-melting equipment on the premises are included with this unit. One label must be posted at the electrical outlet cover. The other label must be posted at the fuse or circuit breaker panel. The labels must be clearly visible.

### 6. Check the installation

- Prior to powering, check to be sure the heating cable is free of mechanical damage (cuts, clamps, etc.).
- Visually check all power connections, end seals, splices, and tees for proper installation.

### 7. Test the ground-fault protection

- Verify the H908 ground-fault device is functioning correctly, according to the instructions in the “Heating cable testing and maintenance” section.

## Electrical protection

### WinterGard Wet H612

Voltage rating:	120 V
Circuit breaker rating:	15 A max.
Max. heating cable length (ft) per circuit for minimum start-up temperature of 0°F:	100
Max. heating cable length (ft) per circuit for minimum start-up temperature of 40°F:	125

The H908 plug contains a built-in 27-mA equipment-protection ground-fault device. This kit provides ground-fault protection of equipment only. It does not protect people against the hazards of electrical shock.

Do not use an extension cord. Plug the unit directly into the outlet.

**Note:** Tyco Thermal Controls and the national electrical codes require ground-fault protection of equipment for de-icing systems.

## Heating cable testing and maintenance

Make sure that gutter and downspouts are free of leaves and other debris prior to the winter season.

Using a 2500-Vdc megohmmeter (Megger) test the WinterGard Wet heating cable circuit prior to installing the H908 ground-fault device but after installing any splices, tees and end seals. Measure the insulation resistance between the heating cable bus wires and the copper braid. If the readings are less than 20 megohms, inspect heating cables for signs of damage and verify the components are correctly installed.

If physical damage is found, the entire damaged section must be removed and a new section of heating cable spliced in using only approved

H910 splice kits.

If physical damage cannot be found, the complete circuit should be removed and replaced with new heating cable.

To verify the ground-fault circuit is functioning, test the H908 before each use. Push in the test button. The indicator light must turn off. Then press the reset button. If the light goes back on, the device is ready to use. Do not use the device if the indicator light does not go on when the device is reset or if the indicator light remains on when the test button is pushed.

Test the H908 functionality before each winter season or more often as required by local code.

**⚠ WARNING:** Shock and Fire Hazard. Damaged heating cable or components can cause electrical shock, arcing, and fire. Do not attempt to energize damaged cable or components. Replace them immediately using a new length of heating cable and the appropriate Raychem accessories.

### Product data—WinterGard Wet H612 heating cable for roof and gutter de-icing only

Service voltage (V)	120
Thermal output at 32°F (W/ft) (in ice and snow)	8
Weight per 100 ft (lb)	9
Minimum installation temp. (°F)	0
Maximum exposure temp. (°F)	150
Exposure to chemicals	None
Environment	Use only in ordinary (nonhazardous) areas.

## H908 Design and Installation Information for Roof and Gutter De-Icing Only (continued)

(WinterGard Wet H612 Heating Cable)

**Note:**

- In all locations, route and secure cable to avoid possible mechanical damage, such as from ladders, etc.
- Neither the ground-fault unit nor the power connection splice can be submerged.

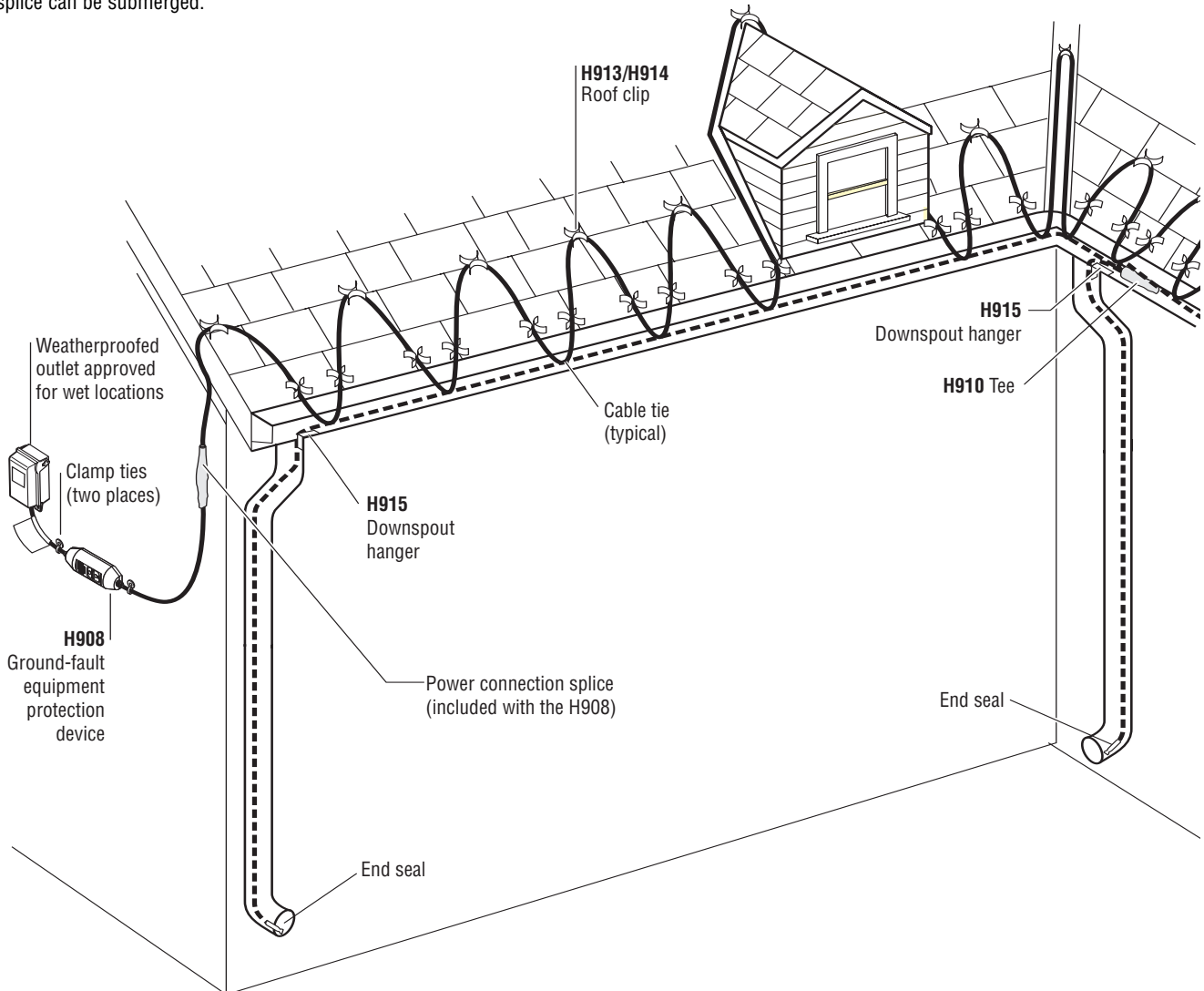

## H908 Installation Instructions – Power Connection Kit

### Identify heating cable

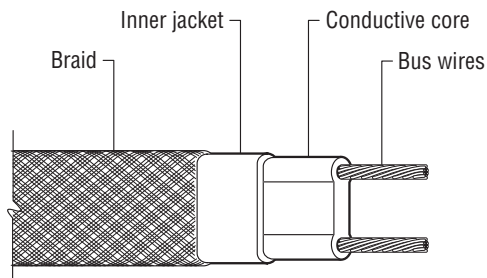

**WinterGard H311 and WinterGard Plus H611**  
Heating cables with braid and no outer jacket

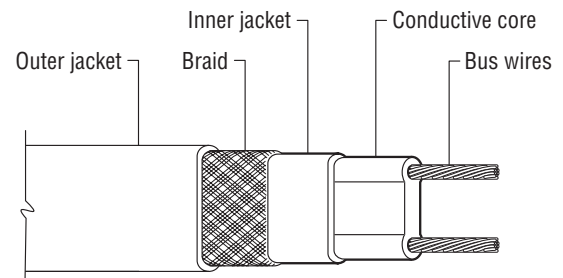

**WinterGard Wet H612**  
Heating cables with braid and outer jacket

**Note:** Instructions generally show heating cable with braid and outer jacket. Cables with no outer jacket look slightly different from those illustrated.

### Stripped end of ground-fault protection device

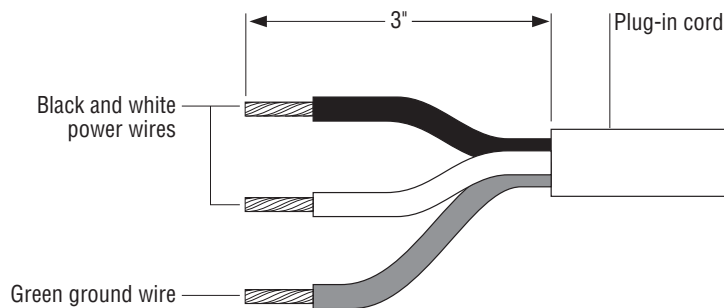

#### 1 For all heating cables

- Slide 8-inch tube and 5-inch tube over end of the plug-in cord.

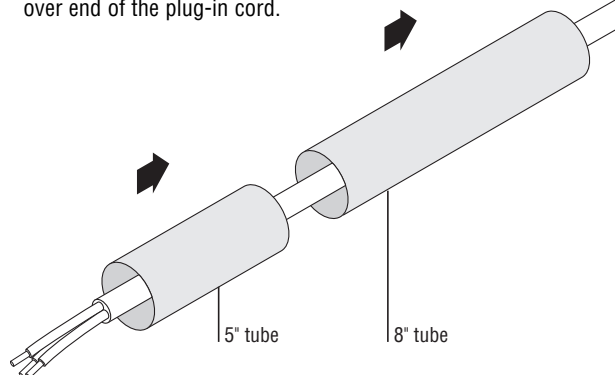

#### 2 For H311 and H611 heating cables only

- Unravel 2 3/4" of braid.

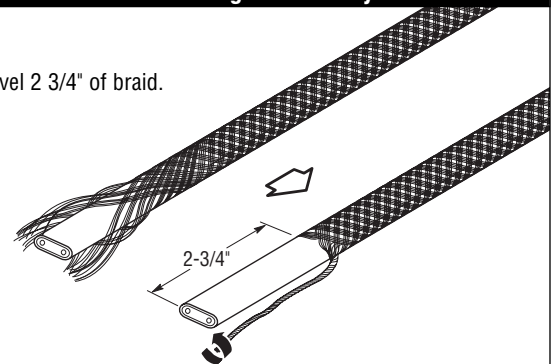

- Straighten the braid and twist into a pigtail.



**H908 Installation Instructions – Power Connection Kit (continued)**

**2b For H612 heating cable only**

- Lightly score completely around and then down outer jacket.
- Do not cut braid or inner jacket.

**2c For H612 heating cable only**

- Unravel the braid back to the outer jacket.
- Straighten the braid and twist into a pigtail.

**3 Remove inner jacket (H612 cable shown)**

- Lightly score completely around and then down inner jacket.
- Do not cut bus wires.
- Bend heating cable to break jacket at score, then peel off inner jacket.

**4 Expose bus wires**

- Notch core at the end.
- Twist back and peel bus wires from core.

**5 Expose bus wires (continued)**

- Score between bus wires at inner jacket.
- Bend core to break free at inner jacket.
- Peel core and any remaining material from bus wires.

**6 Prepare bus wires**

- Slide 1/8" x 1" shrink tubes over bus wires.
- While shrinking, ensure that tubes remain up against black core.
- To shrink tubing move heat source continuously from side to side.
- Trim bus wires.

1  
2  
3  
4  
5  
6  
7  
8  
9

## H908 Installation Instructions – Power Connection Kit (continued)

### 7 Connect bus wires

- Use insulated bus wire crimps and CT-100 crimp tool to connect black and white wires to bus wires of heating cable. Polarity does not matter.

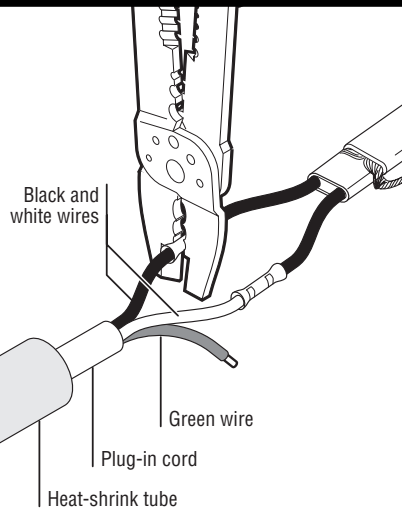

### 8 Apply mastic to bus wires

- Remove release paper from mastic strips.
- Wrap one strip of mastic around the white wire against the end of the splice to provide a water block.
- Repeat for the black wire.

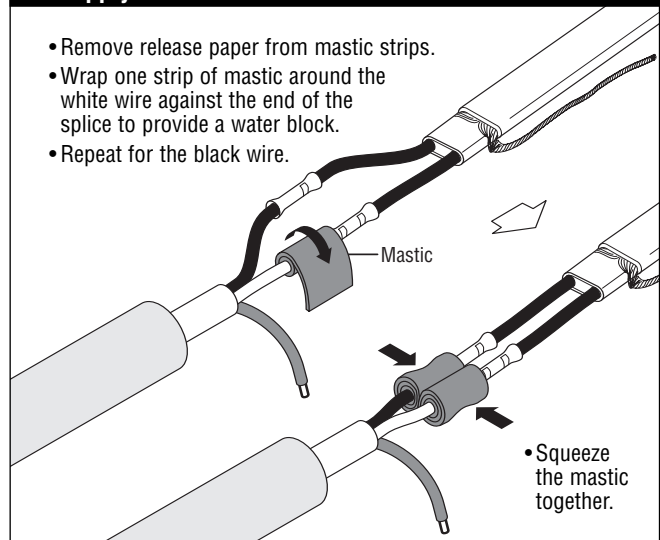

### 9 Apply 5-inch shrink tube

- Center the 5-inch heat-shrinkable tube over the splice. Make sure tube extends over the end of each heating cable and the cord.
- Shrink the tube completely. Start at the middle and work toward each end. Keep heating after tube has shrunk, to melt mastic and adhesive inside tube. Total heating time should be about 2 minutes.

Note: Ring of adhesive will appear at both ends

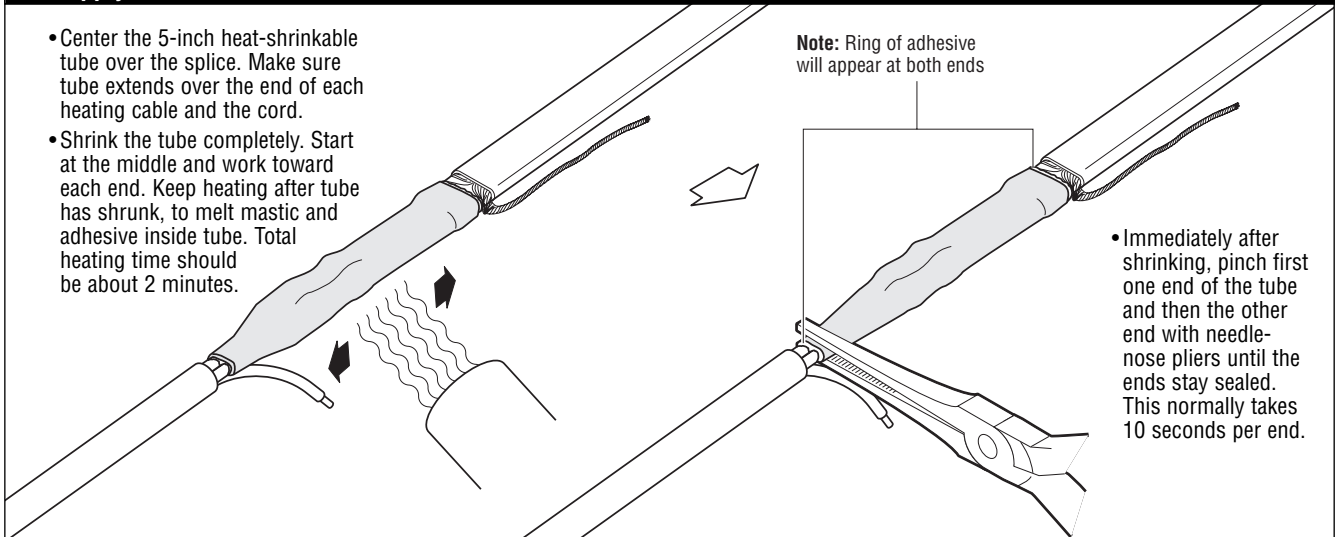

### 10 Connect ground wire

- Use uninsulated braid crimp and CT-570 crimp tool to connect braid to ground wire.
- Wrap black cloth tape evenly around crimp and splice.
- Cover crimp completely.

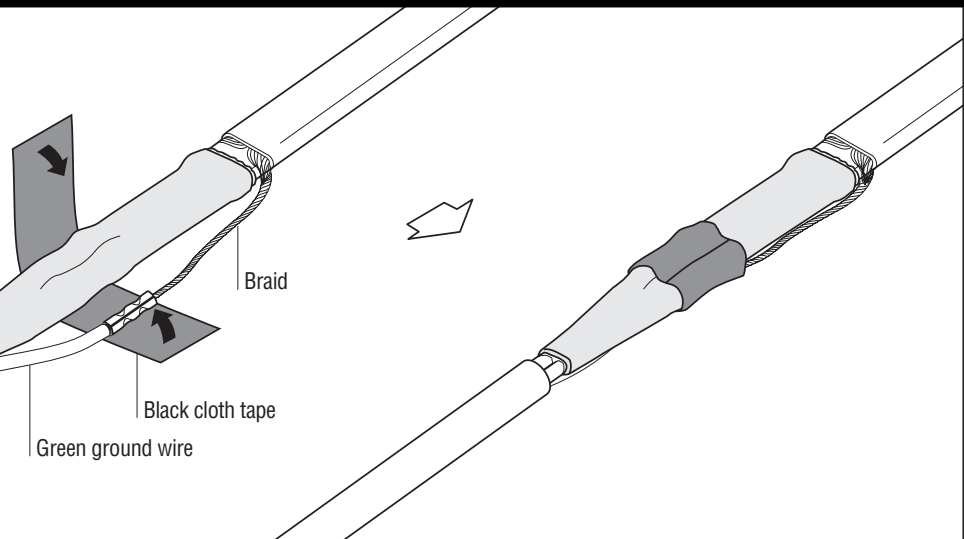

## H908 Installation Instructions – Power Connection Kit (continued)

### 11 Apply 8-inch shrink tube

- Center the 8-inch heat-shrinkable tube over the splice. Make sure that the tube extends over the end of the heating cable and cord.
- Shrink the tube completely. Start at the middle and work toward each end. Keep heating after tube has shrunk, to melt adhesive inside tube. Total heating time should be about 3 minutes.

**Note:** Ring of adhesive will appear at both ends

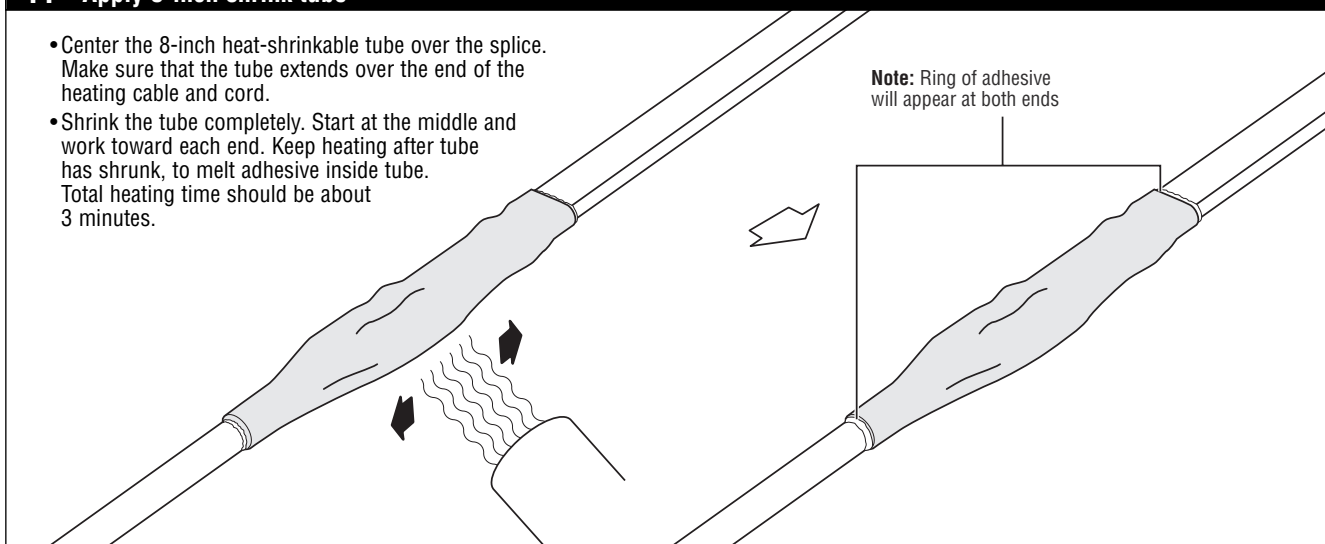

## H908 Installation Instructions – End Seal

**Note:** The end seal is designed to be installed only once; it cannot be removed from the heating cable once installed. Do not use until ready for final installation.

**1 End Seal for H612**

- Cleanly cut off the end of the cable.
- Score down and around outer jacket 1 inch from the end.
- Remove the outer jacket.
- Do not cut or damage inner jacket.

**2**

- Unravel and remove exposed braid.

**3**

- Firmly push end seal onto the cable (at least 1 1/2 inches). Some gel may ooze out.
- Do not twist or try to remove the end seal during or after insertion. Do not reuse an end seal.

**1 End Seal for H311, H611**

- Cleanly cut off the end of the cable.

**2**

- Push the braid back 2 inches from the cable end.

**3**

- Firmly push end seal onto the cable (at least 1 1/2 inches). Some gel may ooze out.
- Do not twist or try to remove the end seal during or after insertion. Do not reuse an end seal.

**4**

- Slide the braid up against the end seal and secure with the 6-inch length of tape provided.

1  
2  
3  
4  
5  
6  
7  
8  
9

## H908 Installation Instructions – Securing the Ground-Fault Device

### 1a For pipe freeze protection

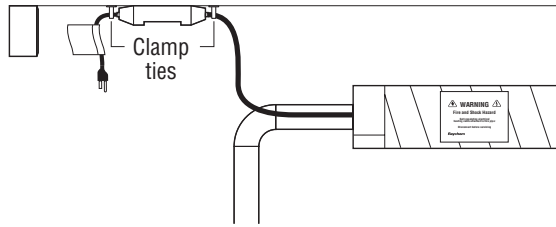

- To prevent damage to the ground-fault equipment protection device and to provide strain relief, use clamp ties to secure the device to the wall near the receptacle. Be careful not to damage either the cord or the ground-fault unit.

**Note:** Pipe must be fully insulated.

### 2a For pipe freeze protection (continued)

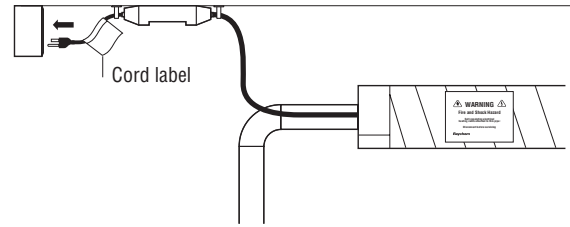

- Plug the heating cable into a 15-A, 120-Vac grounded outlet.
- Make sure that:
  - Cord label is readily visible.
  - Indicator light on the ground-fault equipment protection device is on.
  - Receptacle is properly weatherproofed (if outdoors).
  - Ground-fault equipment protection device and power connection splice will not be submerged.

**Note:** Pipe must be fully insulated

### 1b For roof and gutter de-icing

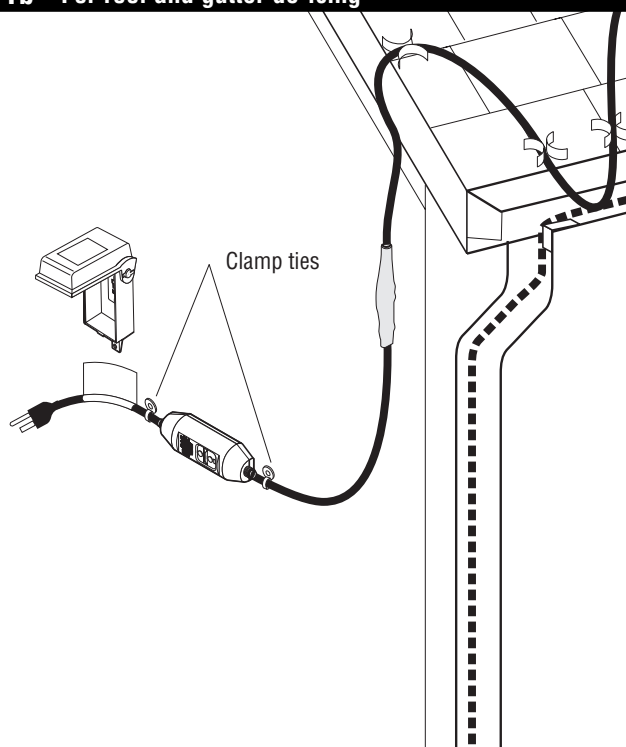

- To prevent damage to the ground-fault equipment protection device and to provide strain relief, use clamp ties to secure the device to the wall near the receptacle. Be careful not to damage either the cord or the ground-fault unit.
- The H908 should be mounted high up, away from passersby to prevent damage to the unit and the risk of shock.

### 2b For roof and gutter de-icing (continued)

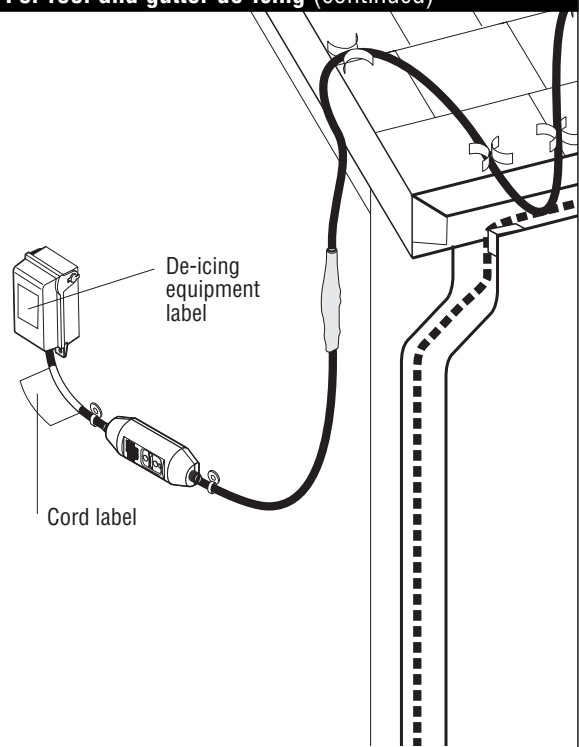

- Plug the heating cable into a 15-A, 120-Vac grounded outlet approved for wet locations.
- Make sure that:
  - Cord label is readily visible.
  - Indicator light on the ground-fault equipment protection device is on.
  - Receptacle is properly weatherproofed.
  - Ground-fault equipment protection device and power connection splice will not be submerged.

## H908 Warranty Information

Tyco Thermal Controls warrants all WinterGard, WinterGard Plus and WinterGard Wet self-regulating heating cables and components against faulty workmanship and use of defective materials for two (2) years from the date of purchase. This warranty can be amended only by a written instrument signed by a duly authorized officer of Tyco Thermal Controls. Buyer's exclusive remedy under this warranty shall be to have Tyco Thermal Controls, within a reasonable time, repair such goods or supply replacement goods or credit Buyer's account for such goods and accept their return whichever Tyco Thermal Controls may elect at its sole discretion. Tyco Thermal Controls shall in no event be liable for the cost of removal or installation, for loss or damage to or loss of use of facilities or other property, loss of revenue, loss of use of revenue, loss of anticipated profits, or other damages or costs of any kind whatsoever, whether direct, indirect, incidental, or consequential.

Notwithstanding the foregoing, Tyco Thermal Controls shall have no liability whatsoever unless: (a) Buyer promptly notifies Tyco Thermal Controls in writing after discovery of an alleged nonconformity and includes a detailed explanation of the alleged nonconformity; (b) Buyer promptly returns the goods to Tyco Thermal Controls postage prepaid, at 300 Constitution Drive, Menlo Park, California 94025-1164, USA; and (c) Tyco Thermal Controls examination of such goods establishes to Tyco Thermal Controls satisfaction that such alleged nonconformities actually exist and occurred in the cause of proper and normal use and were not caused by accident, misuse, neglect, alteration or improper installation, repair or testing or such other cause outside of the responsibility of Tyco Thermal Controls under this Limited Warranty.

**THE FOREGOING WARRANTY IS IN LIEU OF ALL OTHER REPRESENTATIONS, WARRANTIES, OR CONDITIONS, EXPRESS OR IMPLIED,**

**INCLUDING WITHOUT LIMITATION ANY IMPLIED WARRANTY OF MERCHANTABILITY, FITNESS FOR A PARTICULAR PURPOSE OR NONINFRINGEMENT, AND OF ANY OTHER OBLIGATION OR LIABILITY ON THE PART OF TYCO THERMAL CONTROLS, WHETHER BY STATUTE, CONTRACT, STRICT LIABILITY, TORT OR OTHERWISE.**

If the goods are a consumer product in buyer's jurisdiction, the above exclusion or limitation of incidental or consequential damages and the above disclaimer of implied warranties may not apply. The term of any such implied warranty is limited to the term of this two-year Limited Warranty. Some jurisdictions do not allow limitations on how long an implied warranty lasts, so the above limitation may not apply. This warranty gives consumers specific legal rights, and consumers may also have other rights, which vary by jurisdiction.

---

## H908 Design and Installation Information

Notes

---

## H908 Design and Installation Information

*Tyco, Raychem, WinterGard, WinterGard Plus and WinterGard Wet are trademarks of Tyco Thermal Controls, LLC or its affiliates.*

**USA**

**Tyco Thermal Controls**  
300 Constitution Drive  
Menlo Park, CA 94025-1164  
Tel: (800) 545-6258  
Fax: (800) 596-5004  
info@tycothermal.com  
www.tycothermal.com

**Canada**

**Tyco Thermal Controls**  
250 West Street  
Trenton, Ontario Canada K8V 5S2  
Tel: (800) 545-6258  
Fax: (800) 596-5004