

Installation and Service Instructions

For use by heating contractor

VIESSMANN

Vitotron 100 VLN2
Models 04 to 14.4
Wall-mounted Electric Boiler

Heating input: 13.6 to 49.1 MBH
4.0 to 14.4 kW



VITOTRON 100

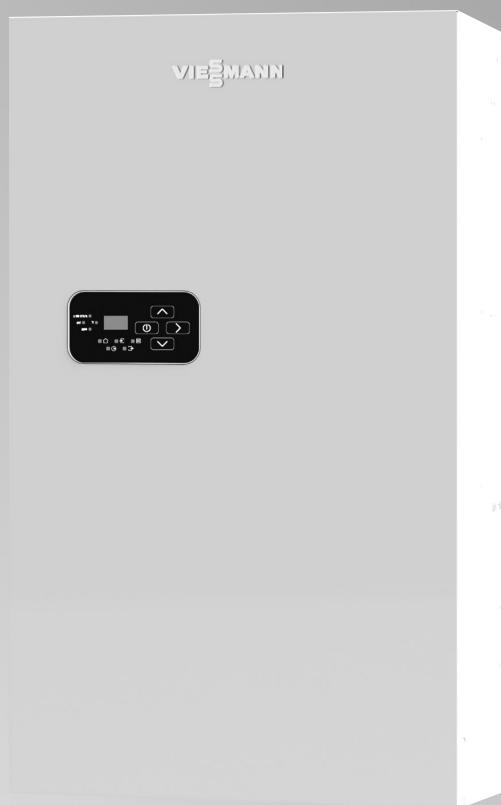

Product may not be exactly as shown

IMPORTANT

Read and save these instructions for future reference.

Instructions for the Installer

Safety Instructions 3
 Electric Boiler Ratings and Specification 4
 Electric Boiler Mounting Clearances 5
 Piping Arrangement..... 6
 Sizing the Electric Boiler 7
 Designed Temperature Differential 7
 Circulating Pump Information 7
 Plumbing Installation Guidelines 8
 Electrical Installation 10

Instructions for the User

Control Panel 12
 Heating Mode / Initial Start-Up 13
 Winter Mode (Heating Mode) 13
 Summer Mode (Stand-by Mode)..... 16
 Advanced Settings 17
 Troubleshooting 18
 Care and Maintenance 18
 General View of the Electric Boiler..... 19
 Parts List..... 20
 Electric Boiler Parts..... 21

IMPORTANT

This appliance is not intended for use by persons (including children) with reduced physical, sensory or mental capabilities or lack of experience and knowledge, unless they have been given supervision or instruction concerning use of the appliance by a person responsible for their safety. Children should be supervised to ensure that they do not play with the electric boiler appliance. Consider all piping and electrical connections before selecting electric boiler location. Failure to follow the instructions in this manual could result in severe personal injury, death or property damage.

Safety Instructions

1. Read and strictly follow the installation and operating instructions to ensure a longevity and reliable electric boiler operation.
2. This manual provides general installation guidelines. Your installation must comply with ALL applicable local codes.
3. ⚠ Always have a qualified electrician perform electrical wiring. Manufacturer will not be held responsible for faulty installations which are performed by unqualified electricians. An efficient electrical installation which has been completed in accordance with the binding norms of electric installation. Electric installation should be equipped with electric circuit breakers and other solutions which will ensure disconnecting the electric boiler from the source of power.
4. All installation work must be performed when the power and water supply is disconnected from the main electrical panel.
5. This electric boiler must be installed vertically and on an even wall surface with access to plumbing connections on bottom.
6. Any associated components (i.e. electric boiler, water tubing, valves, manifolds etc...) must be flushed before electric boiler installation.
7. This electric boiler is equipped with a safety relief valve. Do not install any barrier fitting or valve on the outlet of the safety valve. Connect and extend $\frac{3}{4}$ in. copper piping from relief valve and terminate at least 6 in. from the floor or floor drain.
8. This electric boiler is equipped with a 194°F manual reset safety high limit device. The reset button is clearly located in the center of this device.
9. This electric boiler will not operate below a 7 psi water pressure level.
10. This electric boiler is equipped with a Wilo circulator pump. After thermostat temperature set point has been reached the pump will continue to circulate water for 3 additional minutes as part of a post purge sequence to push heated water away from heat exchanger.
11. This electric boiler is equipped with a differential pressure relief bypass valve. It allows the system to keep minimal flow of heating water through the electric boiler and reduce noise in the installation when equipped with thermostatic zone valves.
12. Do not drain the water from the electric boiler after the heating season.
13. In summer do not shut off the power supply (120VAC and 240VAC) and leave the controller in stand-by (summer mode) between the heating seasons. The electric boiler is equipped with an exercise timer control feature that allows the circulating pump to operate 15 minutes each day and will ensure longer operation the circulating pump and will help to eliminate the buildup of debris. (See section "Summer mode (stand-by mode)" on page 11).
14. The electric boiler is pre-set by the manufacturer to work with hydronic radiant floor, radiant ceiling, hot water baseboard and water to air heat applications. Temperature adjustments can be made on the control panel to meet these applications requiring desired water temperatures between 85° - 140°F.

Electric Boiler Ratings and Specifications

Electric Boiler Model		VLN2 04	VLN2 06	VLN2 08	VLN2 12	VLN2 14.4
Electric Boiler Rated Power	kW	4	6	8	12	14.4
	Btu/h	13,652	20,478	27,304	40,956	49,147
Voltage	V	240				
Rated Current	A	16.66	25.0	33.3	50.0	60.0
Breaker Quantity-Amps	A	1 @ 30 amp	1 @ 40 amp	1 @ 50 amp	1 @ 60/70 amp	1 @ 80 amp
Heating Elements	Quantity	3				
Element Resistance / each	Ω	43.3	28.8	21.6	14.4	12.0

Circulating Pump - Wilo Star S 21 U 15. 3 speed			
Circulating Pump Voltage	V	120V, 60Hz	
Circulating Pump Amps	A	.97	
Speeds		3	
Fuse Rating		2.0 amp	
Operating Temperature Range	°F	85° - 140°	
Inlet / Outlet Pipe Thread		G ¾ in. (Internal Thread)	
Expansion Vessel (14 psi)	Gallon	1.6	
Safety Relief Valve Rating	psi	30	
Maximum Pressure	psi	30	
Minimum Pressure	psi	7	
Weight	Lbs.	68.5	
Dimensions L x W x D	Inches	28 x 17 x 9 ⁷ / ₈	
Minimum Flow Rate	gpm	1.1	1.32

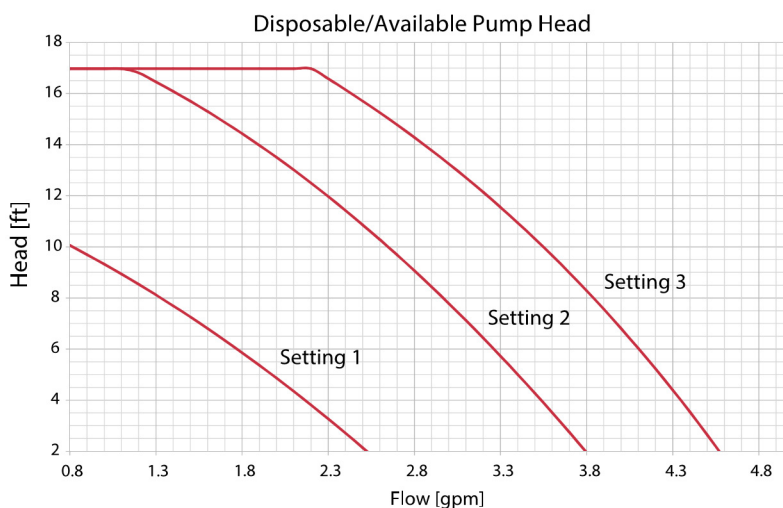

Electric Boiler Mounting Clearances

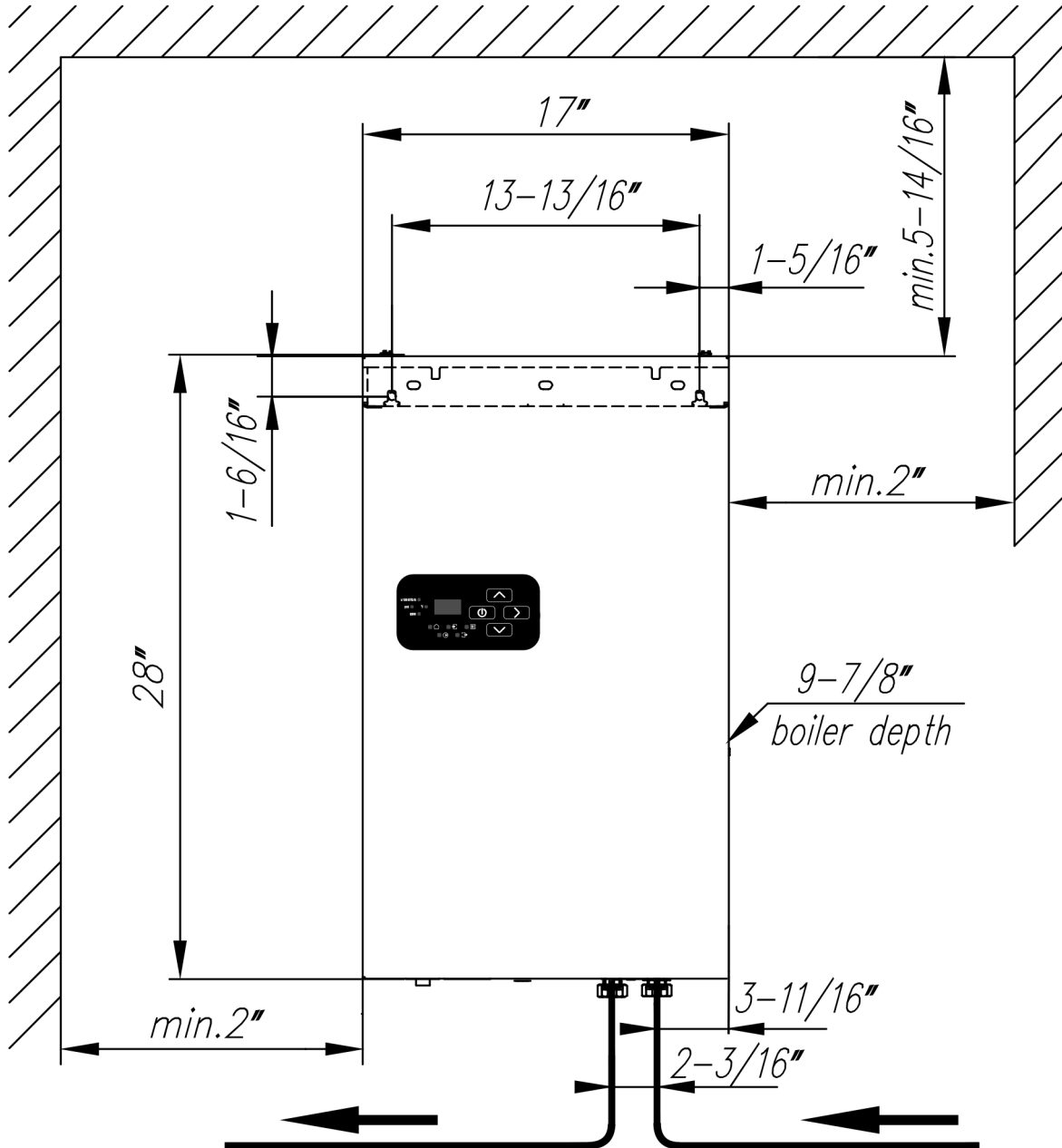

IMPORTANT

After reading instructions, please keep this manual with the electric boiler for future reference. Affix the plastic holder to the outside of the electric boiler and insert manual in this pocket.

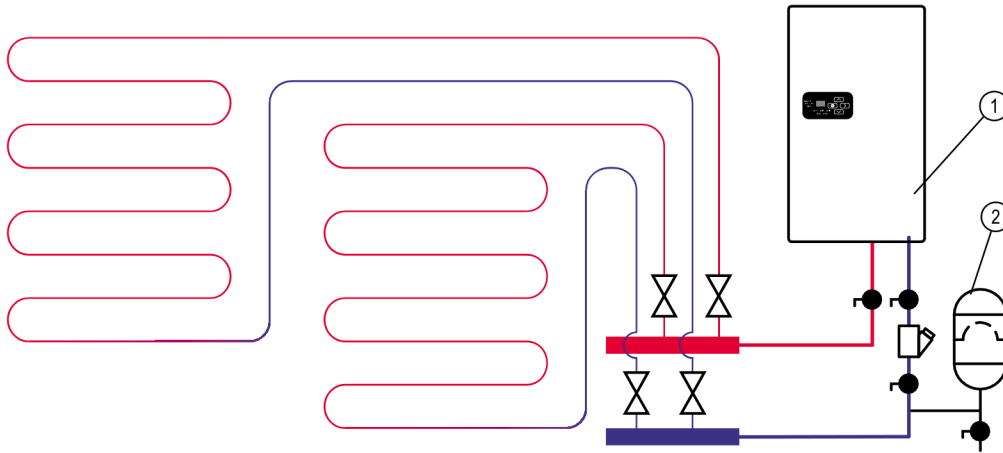

Typical radiant floor heating application

- ① Electric Boiler
- ② Additional expansion tank - if needed

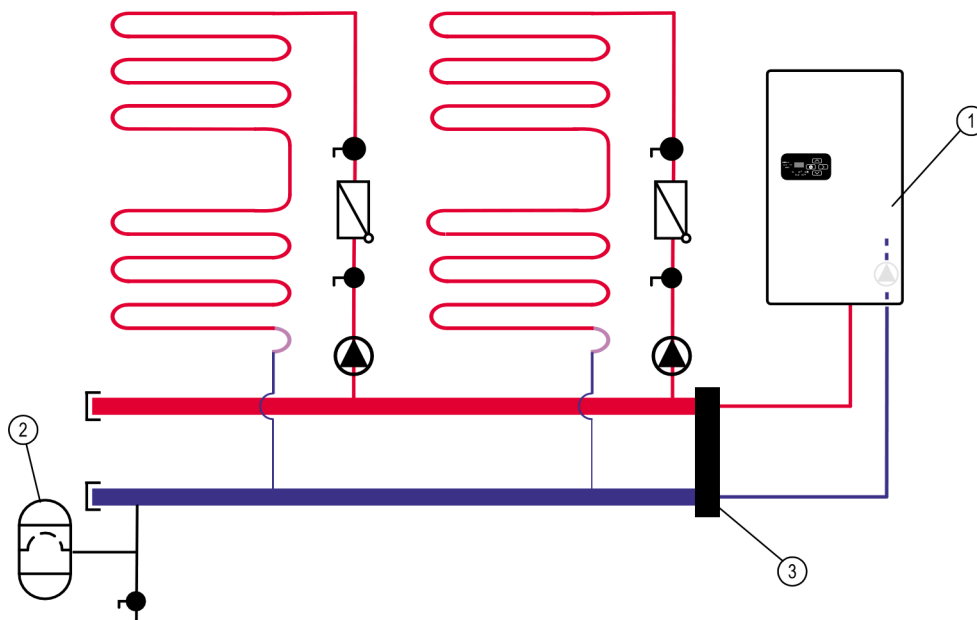

Electric boiler piped in a primary/secondary (P/S) configuration. Consider P/S when higher flow rates are necessary and when the electric boiler meets the intended heatloss of the hydronic system.

- ① Electric Boiler
- ② Additional expansion tank - if needed
- ③ Low loss header

Sizing of the Boiler

It is very important to conduct a heatloss analysis of the intended heated space. Select the electric boiler size in kW based on its Btu/hr. rating that best meets the designed heatloss.

It is important not to overly exceed the kW sizing as this will lead to unnecessary costs of electric boiler, wiring and materials. Consequentially it is extremely imperative NOT to undersize the electric boiler.

How to choose the correct electric boiler size? Convert BTU to kW by dividing the BTU load by 3,413.

(Ex. 33,513 BTU / 3,413 = 9.81kW). Choose a electric boiler that slightly exceeds this kW requirement by no more than 20%.

For larger BTU loads consider cascading the electric boilers together and pipe the system in a parallel configuration as described in the piping arrangement section.

Note: that utilizing propylene glycol freeze protection will reduce the heat transfer and cause the system to be less efficient. Under no circumstance should more than a 50/50 ratio of water to propylene glycol be used. Consult with radiant system designers for required freeze protection guidelines.

Designed Temperature Differential

Radiant floor heating systems are typically designed for a 10°- 20°F temperature differential determined by when the heating fluid leaves the electric boiler and where it enters the radiant heat source. i.e. radiant PEX/tubing.

Circulating Pump Information



This electric boiler is equipped with a Wilo Star S 21 U 15, 3 speed circulating pump. To determine the speed or setting of the pump, confirm with radiant design completed by others and or complete a pressure-loss calculation. Refer to calculations of loop lengths to determine proper speed. The pump will automatically operate based on a thermostat call for heat. After the thermostat temperature set point has been reached, the pump will continue to circulate water for 3 additional minutes as part of a post purge operation to push heated water away from the heat exchanger.

This electric boiler is also equipped with an additional pump relay. This will aid the installer if there is any need to pipe the systems with a secondary circulating pump to overcome pressure drop due to piping or hydronic tubing design. This is commonly referred to as primary/secondary applications described in the piping arrangement section.

Plumbing Installation Guidelines

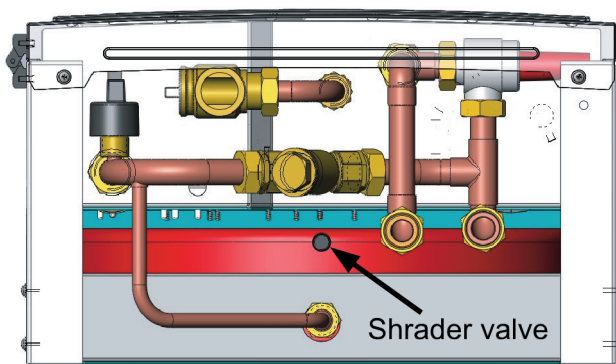

1. Remove outer screws at the bottom and at the top of electric boiler and carefully open the front cover.
2. The electric boiler is wall hung and must be installed in a vertical position where plumbing connections are located at the bottom. Utilize key holes slots to hang the electric boiler. Refer to diagram on clearances (page 5).
3. The electric boiler is provided with a $\frac{3}{8}$ in. air vent located on top of the heat exchanger. It is designed to collect and remove air. Ensure plastic drain tubing remains in place and exits the electric boiler in the lower right corner.
4. The electric boiler is equipped with a pre-charged flat expansion tank located on the back housing of the electric boiler. Expansion tank has a Shrader valve, which location is shown on the figure. This figure presents the bottom view of the electric boiler. Access to the valve is only from the bottom of the electric boiler. From there it can be connected any pressure gauge to check the pressure or pump to refill the air inside the tank.
5. The electric boiler is equipped with an ASME approved 30 psi automatic safety pressure relief valve. Install the necessary length of $\frac{3}{4}$ in. copper piping from the relief valve to within 6 in. of the floor to prevent personal injury or water damage to surrounding area.
6. Observe inlet return piping (blue label) and outlet supply feed piping (red label) connections. Install shutoff valves below inlet and outlet connections before plumbing the electric boiler to the hydronic heating system.
DO NOT reverse these connections to the radiant supply and return manifolds. Optional temperature or pressure gauges can be installed below the electric boiler if desired.
7. Install boiler drain valve(s) as necessary to aid in filling, purging and draining of unit and the related system components.
8. Water supply feed or pressure reducing valve can be installed to comply with local building codes. Local codes may require a back flow preventer called a check valve when installing a fixed domestic water supply line to the electric boiler.

Plumbing Installation Guidelines *(continued)*

9. When possible, fill the electric boiler and hydronic system with treated water. (i.e. soft or distilled water) This will substantially extend the life of the heating elements and reduce sediment buildup.
10. Freeze protection additives can be added. Only use propylene glycol type freeze protection products for hydronic heating systems that are non-toxic and corrosion resistant.
The propylene glycol mix shall not exceed 50%, by volume. ⚠ Under no circumstance should methanol or ethylene glycol (automobile antifreeze) be added to the electric boiler system as this may damage internal components.
11. Insure purging of all air throughout electric boiler system and related components.
12. This electric boiler requires a minimum pressure of 7 psi in order to operate. Pressure levels for hydronic systems typically are above the pre-charged expansion tank pressure level (12 psi). If additional pressure gauges are installed verify reading as described on item 7.
13. The electric boiler is equipped with a pressure differential bypass valve. This allows the minimum flow rate to pass through the electric boiler when all zone valves are closed. The valve will also help reduce noise issues upon closing of zone valves or actuators.

To adjust:

Turn differential bypass valve clockwise until it stops. Turn on all heating zones and let them heat for a couple of minutes.

Caution! piping can get hot quickly upon opening the valve. Slowly open the bypass valve by turning in a counter clock wise direction.

Stop turning once an increase in temperature is felt on the outlet side of the valve. This is referred to the tipping point. After reaching the tipping point continue to turn the valve one complete turn. The valve is now set to bypass excess flow as zone valves close. Set the thermostats to normal set temperatures.

14. Proceed to the Electrical Installation.

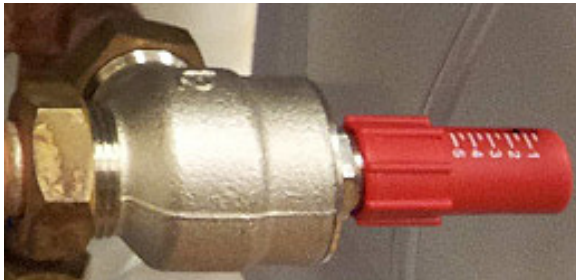

Electrical Installation

Electrical Wiring Diagram

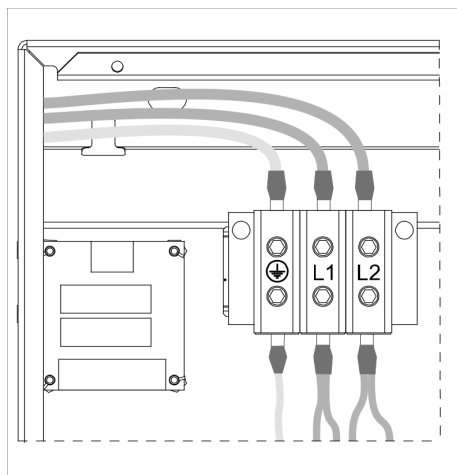
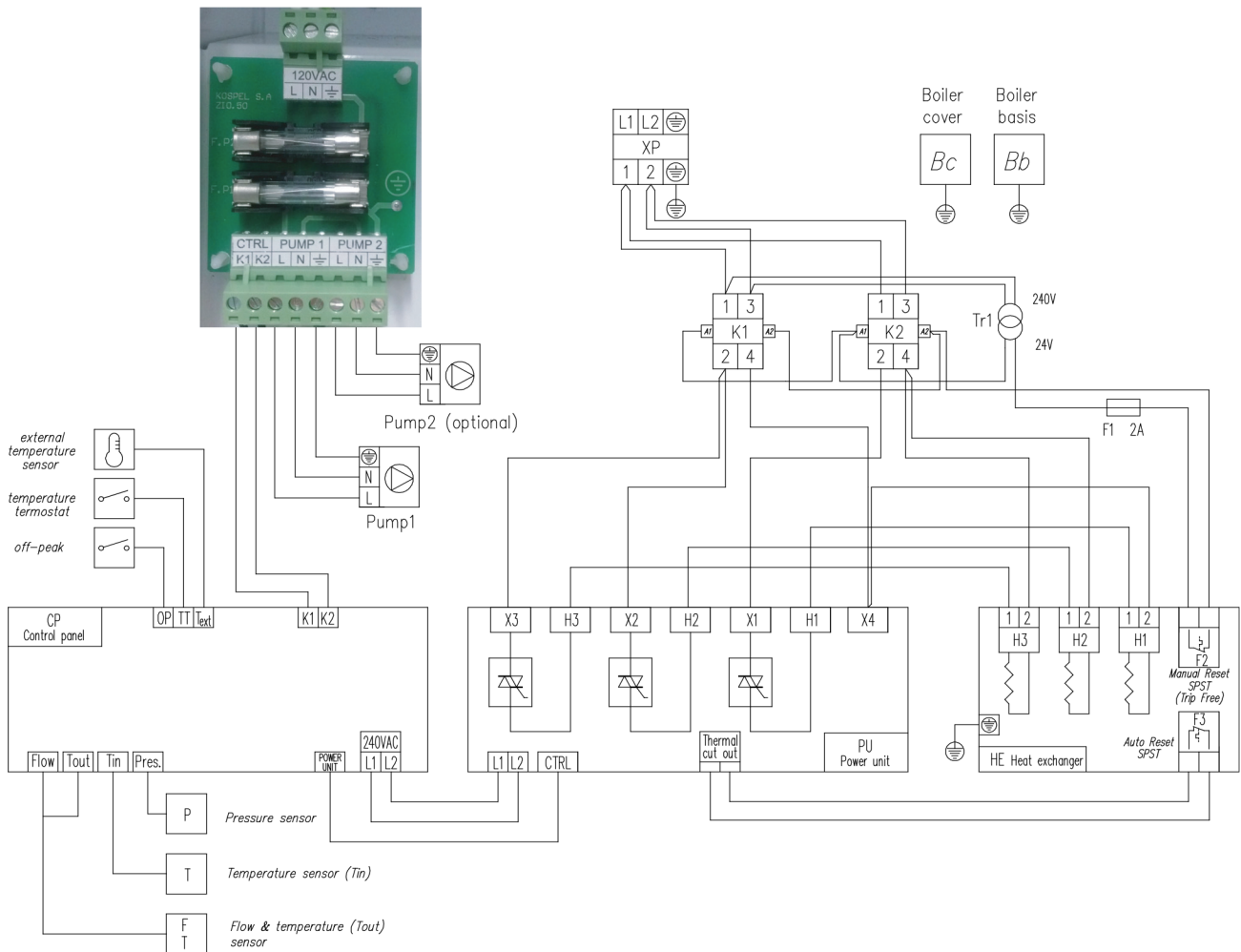

⚠ For supply connections, use 10 awg or larger wires suitable for at least 167°F (75°C)

1. All electrical work should be completed in accordance to local or state electrical and building codes.
2. This electric boiler must be electrically grounded in accordance with National Electrical Code ANSI/NFPA70, or local codes.
3. This electric boiler operates with 240VAC single phase electrical power source.
4. Connect the electric boiler to the electrical service using **⚠ COPPER WIRE ONLY**. Tighten connections by using a 3/16 in. Hex key tool. Conform to local electrical codes for correct sizing of electrical breakers and size of electric conductor wires. Refer to electric boiler nameplate for current and kW ratings. Local electric codes may require an electrical disconnect.

Electrical Installation *(continued)*

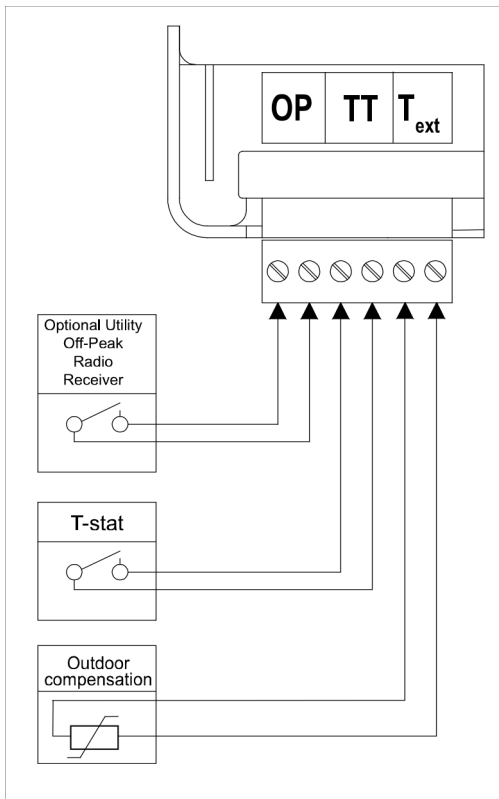

5. The circulating pump requires a separate 120VAC, 15 amp electrical circuit. Utilize ½ in. electrical knockout as marked on the left side of cabinet to access circulating pump wiring connections inside electric boiler. Do not combine the high voltage power for circulating pump with any thermostat or off peak low voltage wires.
An optional secondary pump can be installed in the system for hydronic applications plumbed with multiple circulators and or primary/secondary applications. Utilize the Pump 2 connections to operate the secondary pump. The secondary pump will automatically turn on upon closure of thermostat connections on control panel. Spare fuses are taped into the inside cover.
Fuses specified as:
Time-delay Glass Fuse 6.3 x 32 mm 2A.
6. Thermostat - This electric boiler can be signaled to turn on from a standard two wire thermostat, end switches of an actuating valve or a zone control panel. These connections should all be voltage free (dry contact). Extend wires from thermostat to TT connections on control panel using 2 x 18 gauge wires. Utilize ½" electrical knockout to left side of control panel to gain entrance to this connection. Install thermostat in a location where it will not be influenced by other heat sources.
7. Off peak control (optional) -This electric boiler is equipped with a connection (normally closed) to receive a utility signal for off peak denoted by OP on the control board. Ensure the interconnection from utility radio receiver is voltage free (dry contact). Consult with local utility on questions with off-peak installations. Keep blue/white jumper wire in place if not connected to a utility radio receiver.
8. Outdoor compensation - The electric boiler can utilize an outdoor sensor for outdoor compensation capability. Install the outdoor sensor preferably on the north side of the building. Keep the outdoor sensor away from any sources of heat.
Refer to Advanced Settings on page 14 to set proper heat curve. If no outdoor sensor is wired to the T_{ext} terminals on the control panel, the electric boiler will work in normal operation
9. Final check. Verify all electrical connections are tight. Loose connections can cause premature failures of electrical components. Once you have finished the above procedures and before starting the electric boiler, understand the control buttons and indicators on the control panel in the following page.
10. Re-fasten the screws on bottom (2) and top (1) to hold front door in place.

Control Panel

The control panel consists of two working areas: the signaling area and control buttons. The user can select the following working modes: winter mode (heating mode) or summer mode (stand-by mode). Utilize the push button arrows to scroll through the different working parameters of the electric boiler. The control panel will automatically switch to main view if no buttons are pressed within 1 minute. After learning the indicators proceed to initial startup section.

The control panel allows the user to identify flow rate (GPM), the inlet and outlet operating temperatures and the Btu/h of the electric boiler at any given time. It will also aid in identifying any faults, which may occur, by displaying the fault codes.

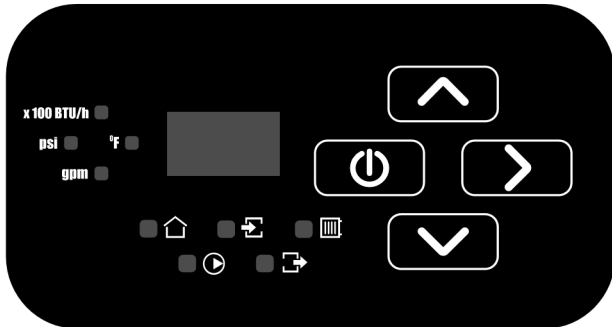

Indicators

X 100 Btu/h = British thermal units per hour

psi = Pounds/Square Inch, pressure level

gpm = Gallons/minute or Flow rate

F° = Temperature (Fahrenheit)

Buttons

⏻ = Power





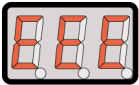
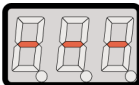

▲ / ▼ = Up and down selection

▶ = Scroll option

Failures indication













Indicator	Status	Details
	EEE Message on electronic display	Data record error
		Parameter out of range or a failed temperature sensor

Heating Mode / Initial Start-Up







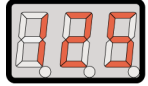





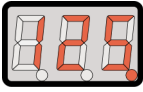
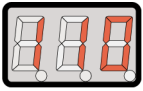

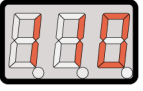
- To set in the heating mode press the power button . The indicators will show the current working mode of the electric boiler.
- Set the supply water temperature (SWT) set point. Utilize the right arrow  push button to scroll through working parameters of the electric boiler. Highlight the SWT symbol  and utilize the up and down arrows  /  to select the temperature that meets hydronic radiant heating application. The supply water temperature can be set between 85° - 140°F. Notice the °F symbol will light up at the same time when changing temperature.
- If 120VAC power is connected to the circulating pump, turn control panel on  and utilize push buttons to scroll to psi indicator. Disconnect thermostat wiring connection below control panel. This will insure electric boiler will not operate. If pressure is below the 7 psi level the circulating pump indicator will blink. Verify pressure (psi) reading on control panel to achieve desired pressure levels. Typical pressure readings should be slightly above the 12 psi expansion tank reading or higher depending on application (15-20 psi recommended).
- For testing, turn the thermostat above the room temperature reading. This will turn the electric boiler on. After testing return the thermostat to a comfort setting.
- To automatically return to main viewing mode momentarily press the power  button. The controller will switch over to the main view if you don't push any of the buttons for 1 minute.

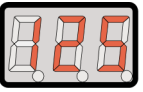
Winter Mode (Heating Mode)

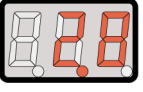
To set in the heating mode press the power  button. The indicators will show the current parameters of the electric boiler (see control panel).

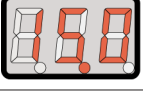
MAIN VIEW		
INDICATOR	STATUS	DETAILS
Heating Status		
	 on	Thermostat is calling for heat
	 off	Room set temperature has been reached/ no call for heating
	 blinks	Off Peak load control or master appliance mode. Outdoor temperature reached a thermal cut - off valve (see parameter 5 in advanced settings).
Circulating Pump Indicator		
	 on	Pump is active, proper flow rate of water has been reached
	 blinks	Lack of water flow or insufficient flow of water heating elements off
Supply Water Temperature		
	 red light	Electric boiler is in heating mode
	 green light	Supply water temperature has been reached in the electric boiler
	 off	Heating is off
Outlet Temperature		
 °F 		Temperature on the outlet of the electric boiler

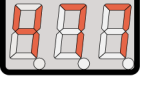
Winter Mode (Heating Mode) *(continued)*

SUPPLY WATER TEMPERATURE VIEW		
INDICATOR		DETAILS
 °F 		The LED in the first location on the display indicates automatic setting, according to the heating curve and offset (see parameters 4 and 5 in advanced settings). This is active only when the outdoor sensor is wired to Text terminals on control panel.
		Manual setting (see parameter 4 in advanced settings), outlet temperature can be set manually in range 85 - 140°F. Use buttons ▲ and ▼ to change the parameter.
INLET TEMPERATURE VIEW		
°F  		Inlet temperature
OUTLET TEMPERATURE VIEW		
°F  		Outlet temperature
FLOW VIEW		
gpm 		Flow rate [gallons/min.]
PRESSURE VIEW		
psi 		Pressure level [pounds/square inch]
ENERGY CONSUMPTION VIEW		
X100 BTU/h 		Current energy consumption [BTU/h]
OUTDOOR TEMPERATURE VIEW		
°F  		Outdoor temperature. In case of lack of outdoor temperature sensor, preview is not available

Winter Mode (Heating Mode) *(continued)*

To use the outdoor compensation option refer to outdoor compensation graphs on page 14. The outlet temperature is adjusted depending on the outdoor temperature.

For example, if it's cold, the outlet temperature should increase, but if outdoor temperature is warmer, the outlet temperature should be adjusted lower. Outdoor compensation option is based on heating curves (see "Advanced Settings").

User can choose from one of the 9 curves available, declaring the desired thermal efficiency of the electric boiler.

One method of selecting the correct curve is as follows. The first step is to determine the temperature on the horizontal axis (outside temperature from 0°F to 70°F), which at the present time most frequently occurs, for example 30°F.

Then run in a straight line up to the height on the value of the temperature on the vertical axis which we want to obtain in the hydronic system. In our example, at 30°F outside the building we want to have 115°F for the heating (see the diagram on page 14), so we get exactly the heating curve defined as 4. If the intersection point of selected temperatures is not placed on the curve, we choose the closest. For example, 30°F outdoor temperature, and the desired 110°F for hydronic system can lead to a selection of curve 3 or 4. It should be checked periodically, whether the choice was correct, if not - another curve should be used.

The heating curve offset

If in wide range of outdoor temperatures the electric boiler is not able to maintain the desired indoor temperature (it's too cold or too warm), the heating curve chosen before should be shifted (offset in range -9°F to +9°F available in options on control panel). If the indoor temperature is too warm - the heating curve should be shifted down and vice versa (refer to the diagram on page 14).

Special start-up procedure (when the system is filled with an antifreeze solution)

A flow rate reading error may occur if you start-up the unit at low ambient temperature. This error may occur because the physical properties of antifreeze solution.

If the  indicator flickers and the cut-off valves are opened you have to close OP and TT contacts which will automatically start the special start-up procedure.



As a result, the medium will be warmed up to temperature that enable you to read the flow rate correctly.

The duration of procedure depends on both the installation capacity and the temperature inside the installation.





When a control panel display shows selected parameters alternately and marks („-", „--", „---") it means that the procedure is started. The procedure will close automatically and the unit will start normal operation once the minimal flow rate is reached.

Summer Mode (Stand-by Mode)

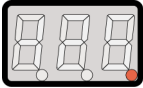

IMPORTANT

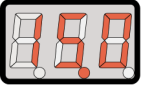



Do not shut off the power supply between heating seasons. To set the electric boiler to summer or stand-by mode press and hold  power button for 3 seconds. When the control panel is switched to summer mode the control panel is off and the stand-by mode indicator  remains blinking. In this mode the electric boiler is off but the pump is activated every day for 15 minutes. This summer mode protects the electric boiler and the hydronic heating installation from being blocked and silted up. The pump will run every day at the same time when the electric boiler is switched to summer mode. For example, if you turn the electric boiler to “stand-by” mode at 6 p.m. the timer will activate the pump every day for 15 minutes starting at 6 p.m. To set the electric boiler back to winter heating mode press and hold power button  for 3 seconds.





Note: In summer mode, based on U.S. national electric rates of \$.10/kWh the cost of operating the circulating pump for 15 minutes/day will equate to approximate usage of \$.08 / month on the highest speed.







MODE VIEW	
INDICATOR	DETAILS
	The control panel is off and the stand-by mode indicator (dot) blinks only.
PRESSURE VIEW	
psi  	Pressure level [pounds/square inch]. To check out the installation pressure press or
STATUS PUMP VIEW	
	Circulation pump is active. In summer mode (heating elements turned off). The circulating pump will operate for 15 minutes, once every 24 hours each day.

Advanced Settings

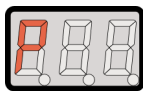
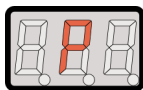
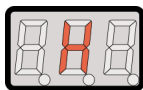
To enter advanced settings the control must first be put into standby mode. Enter standby mode by pressing and holding the power button  (Approx 3 seconds) until the display goes blank, once the display goes blank, release the power button . Confirm the control is in standby mode by observing the flashing red dot in the bottom right corner of the blank LCD display.

To make changes to a parameter use the up and down arrows ,  and select the desired value. To advance to the next parameter press the right arrow button . Once you have finished setting the parameters, press and hold the power button  until the display goes back to stand by mode (blank with intermittent red dot). The settings have now been changed and you can press the power button  to turn the boiler back on.

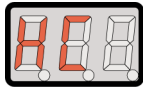
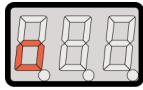
With the display in standby mode, extended parameters can be entered by pressing and holding the right arrow button , while still holding the right arrow button  press and immediately release the power button . The display will illuminate and display the first parameter group, you can now release the right arrow button .

Parameters	Indicator/display	Status/value	Details
1		4-14	Electric boiler - enter the power amount (kW) as indicated on identification label. This value is factory preset.
2		A/n	Working mode of pump – PA = (automatic), Pn (manual – continuous duty of pump).
3		1, 2, 3	Maximum quantity of active heating elements.
4	 psi	off/on	Installation pressure control
5	 °F	30-70	Outside temperature above which electric boiler will not heat, in case of electric boiler's failure or lack of outside temperature sensor, function is not active
		off	Function not active
6		1-9	Selection of heating curves (see diagram "Outdoor compensation")
		0	Manual setting of outlet temperature
7		-9 ÷ 9	Offset of heating curve characteristic [°F] (see diagram "Offset for outdoor compensation")
8			Electric boilers working time counter in hours

Outdoor compensation

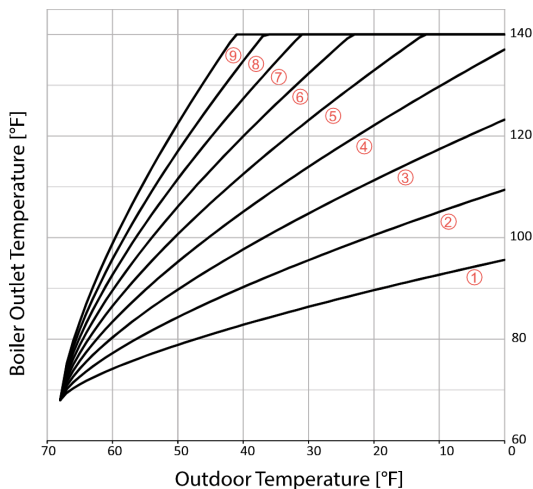

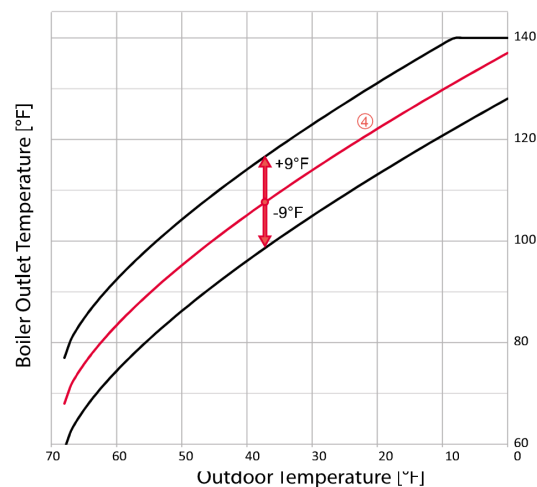

Offset for outdoor compensation



Troubleshooting

⚠ Do not attempt to service this electric boiler unless you have been trained in all aspects of its functionality and methods to repair.

Failure to service properly may lead to further damage to components.

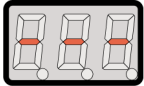
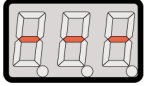
Symptom	Reason	Action
All indicators on control panel are OFF	No power to electric boiler	Check for 240 VAC on electric boiler main connection terminals
		Reset manual safety high limit
		Contact authorized service person
"PSI" indicator blinks	Insufficient pressure below 7 psi	Switch the controller to pressure view and increase system pressure above the minimum required 7 psi level.
	Pressure sensor failure	Switch the controller to pressure view, if display shows - - Contact authorized service person
"GPM" indicator blinks	Pump is blocked	Unblock the pump-unscrew the screw on pump housing and move the pump rotor manually
	Heat does not circulate through the electric boiler – electric boiler is blocked	Air bubble is caught in system, purge the installation, pump and electric boiler Check 1 amp fuse on control panel
	Failure of pump or flow sensor	Check power supply for circulating pump
	a failure of pump or flow sensor	Contact an authorized service or the seller
 Circulator indicator blinks	Lack of water flow - 2.1 GPM min	Adjust flow characteristics as needed
 "Heating status" is off	No thermostat connection	Insure thermostat is calling for heat and is above ambient temperature set point Verify connections on thermostat
	Failure of control board	Check fuse on control panel glass fuse 6.3 x 32 mm 2A
 "Heating status" blinks	Off Peak signal = no heat	Electric utility off peak control
 and "Inlet temp." blinks	A failure of inlet temperature sensor, electric boiler in failure condition	Check connection or replace thermistor sensor
 and "Outlet temp." blinks	A failure of outlet temperature sensor or loose connection	Check connections Replace HC-DN 15 sensor
Electric boiler does not heat	Failure of cylinder temperature sensor	Contact authorized service person for replacement of cylinder temperature sensor or thermostat
	A failure of control panel	Contact authorized service person
EEE message on display	Data record error	Contact authorized service person
Insufficient heat output	Heating elements	Check for resistance on elements
	Control panel set up failure	Insure control panel is set up for correct kW and number of heating elements through advanced settings

Care and Maintenance

- In order to protect flow sensor located within the electric boiler, it is imperative that the pre-installed magnetic filter is removed and cleaned at least annually. Failure to clean out this filter could increase contamination of the electric boiler by system residue.
- Periodically check system pressure. Contact authorized service person to make adjustments only.

General View of the Electric Boiler

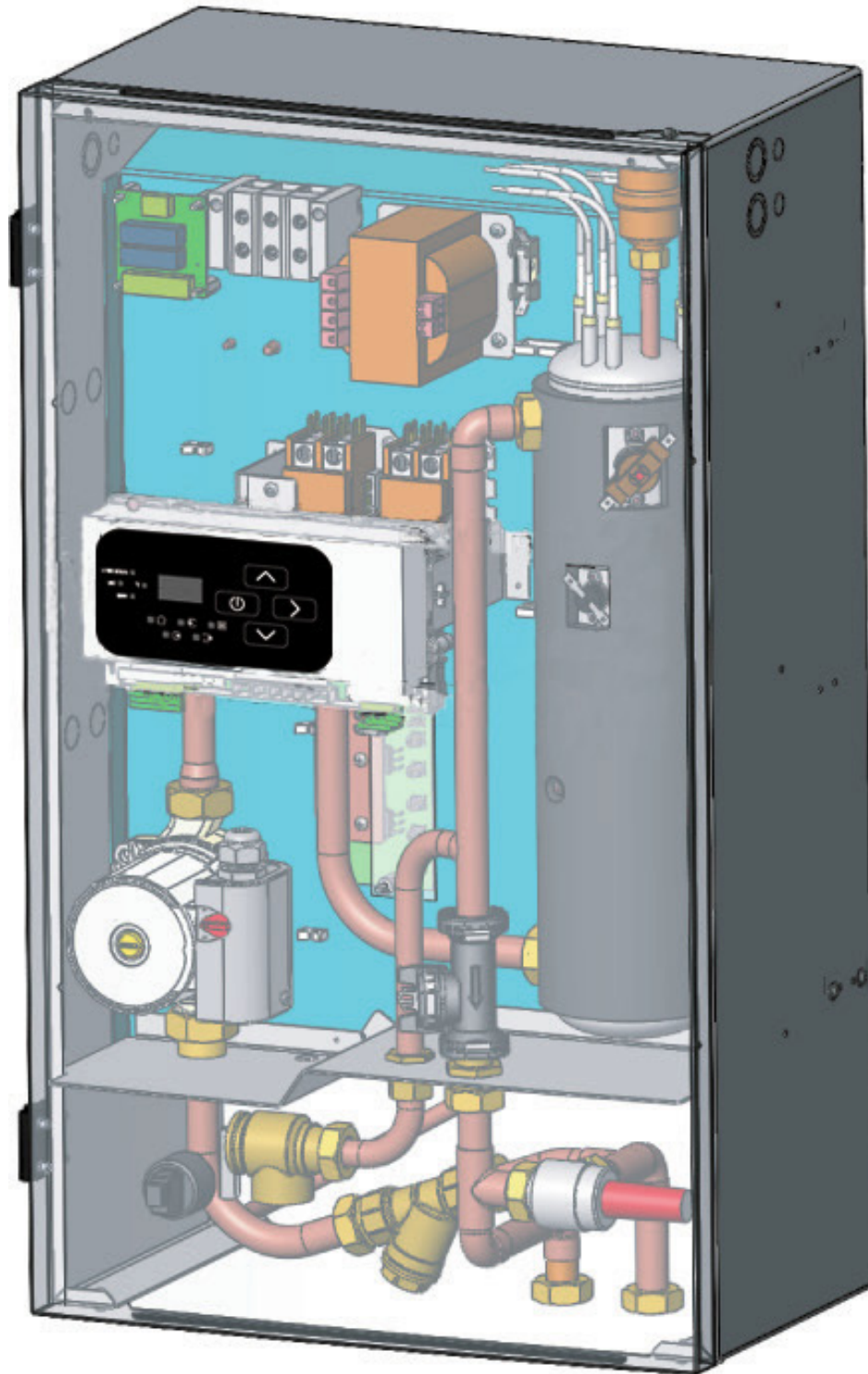

Part List

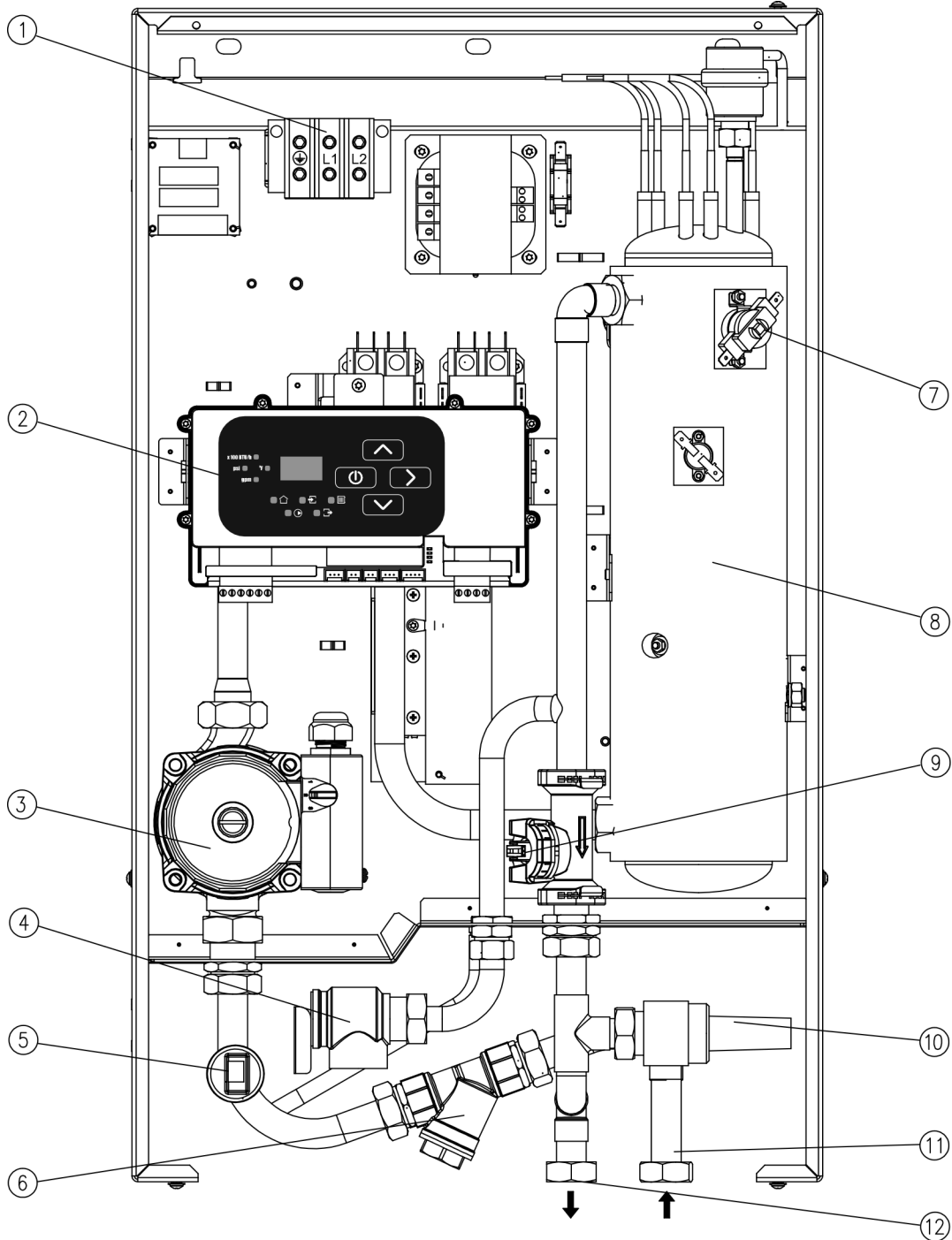

Legend

- | | |
|-------------------------|--------------------------------------|
| ① Wiring Entrance | ⑦ Manual Reset High Limit Device |
| ② Control Panel | ⑧ Heating Element |
| ③ Pump | ⑨ Flow and Outlet Temperature Sensor |
| ④ Pressure Relief Valve | ⑩ By-Pass Valve |
| ⑤ Pressure Sensor | ⑪ Water Inlet |
| ⑥ Magnetic Filter | ⑫ Water Outlet |

Electric Boiler Parts

Part Number	Description
7873767	AUTOMATIC AIR-VENT VALVE VLN2
7636748	GASKET 1.5X8X14.8 VLN2
7857710	GASKET 1.5 X 11.7 X 18.2 VLN2
7636745	GASKET 2 X 20 X 30 VLN2
7873768	EXPANSION VESSEL 6L G1/2" VLN2
7636746	GASKET 1.5 X 16 X 24 VLN2
7636731	PRESSURE TRANSDUCER VLN2
7873769	DIFFERENTIAL PRESS. VALVE 3/4" VLN2
7873770	O-RING SEAL GASKET 70NBR VLN2
7873771	MAGNETIC FILTER 3/4" VLN2
7873772	FLOW TEMPERATURE SENSOR DN15 VLN2
7873773	CASE SET, BACK VLN2
7873774	HEATING BOX 6KW/240V VLN2
7873775	HEATING BOX 8KW/240V VLN2
7873776	HEATING BOX, 12KW/240V VLN2
7873777	HEATING BOX, 14.4KW/240V VLN2
7873778	RETURN, CONNECTION PIPE VLN2
7873779	PUMP CONNECTION PIPE, INTERNAL VLN2
7873780	POWER BOARD, WITHOUT CONNECTION VLN2
7873781	POWER BOARD, W/ CONNECTION VLN2
7873782	FLOW CONNECTION I VLN2
7873783	FLOW CONNECTION II VLN2
7873784	CONTROL PANEL PSK.P7 VLN2
7873785	FRONT COVER VLN2
7873786	NIPPLE, 3/4" VLN2
7873787	NUT, 1/2" VLN2
7873788	NUT, G3/4" VLN2
7873789	CONNECTION PIPE VLN2
7873790	BUSHING VLN2
7873791	BOARD, ZIO 50 VLN2
7873792	CIRC PUMP (WILO) STAR S21U-15 VLN2
7873793	THERMAL SAFETY, 60T-X25 VLN2
7873794	CONTACTOR (HARTLAND) 40A 2P VLN2
7873795	TRANSFORMER, (TEC) 24V VLN2
7873796	FUSE SOCKET VLN2
7873797	FUSE, 6.3X32MM 2A VLN2
7873798	HEATING BOX, 4KW/240V VLN2
7873799	ELECTRICAL CONNECTOR, VC05-0013 VLN2
7873800	HOLDER, KU-2 GRAY VLN2
7873801	THERMAL CUT-OUT, 36T AUTO RESET VLN2
7873802	RETURN TEMP SENSOR NTC VLN2
7636749	O-RING 14 X 2 VLN2
7873805	SAFETY VALVE W/CONNECTION PIPE VLN2

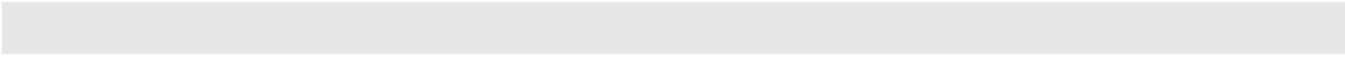

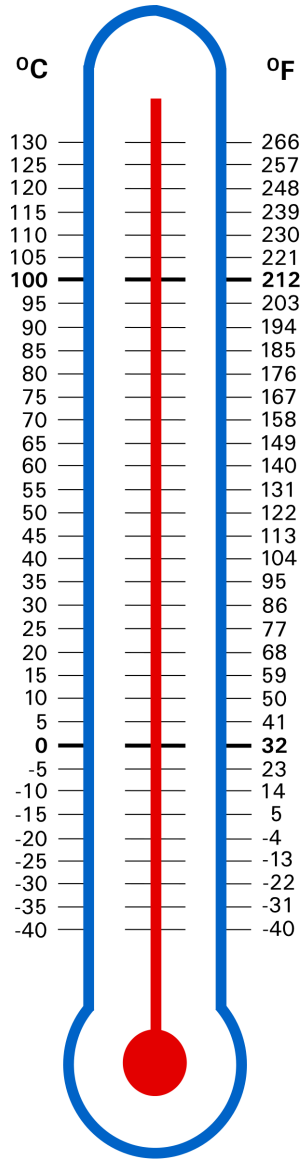

Printed on environmentally friendly (recycled and recyclable) paper.



Technical information subject to change without notice.

Scan for digital copy of this document



Viessmann Manufacturing Company Inc.
 750 McMurray Road
 Waterloo, Ontario • N2V 2G5 • Canada
TechInfo Line 1-888-484-8643
 1-800-387-7373 • Fax (519) 885-0887
www.viessmann.ca • info@viessmann.ca

Viessmann Manufacturing Company (U.S.) Inc.
 45 Access Road
 Warwick, Rhode Island • 02886 • USA
TechInfo Line 1-844-649-5886
 1-800-288-0667 • Fax (401) 732-0590
www.viessmann-us.com • info@viessmann-us.com