

Series 63/64™

Gas Boilers



Installation, Operation & Maintenance Manual



PeerlessBoilers.com

TABLE OF CONTENTS

USING THIS MANUAL	1	5. FUEL PIPING	17
A. MANUAL ORGANIZATION	1	A. INSTALLATION	17
B. SPECIAL ATTENTION BOXES	1	B. OPERATION	17
1. PREINSTALLATION	2	6. CONTROLS & TRIM	19
A. GENERAL	2	A. STEAM BOILER CONTROLS & TRIM	19
B. CODES & REGULATIONS	2	B. WATER BOILER CONTROLS & TRIM	20
C. ACCESSIBILITY CLEARANCES	2	7. ELECTRICAL	22
D. CLEARANCE FROM COMBUSTIBLE CONSTRUCTION	2	A. CONNECT SUPPLY WIRING	22
E. AIR COMBUSTION AND VENTILATION	3	B. MOUNT REMAINING CONTROLS	22
F. INSTALLATION SURVEY	6	C. INSTALL CONTROL WIRING	23
G. PLANNING THE LAYOUT	6	8. BOILER OPERATION	29
2. BOILER PLACEMENT & ASSEMBLY	7	A. SYSTEM INSPECTION	29
A. PACKAGED BOILER	7	B1. FILL THE BOILER (WATER BOILERS)	29
B. KNOCKDOWN BOILERS – SPLIT BLOCK	7	B2. FILL THE BOILER (STEAM BOILERS)	29
C. KNOCKDOWN BOILERS – ASSEMBLED BLOCKS	8	C. OPERATING INSTRUCTIONS	29
D. KNOCKDOWN BOILERS – CONTROL & MANIFOLD ASSEMBLY	8	D. PILOT CHECK	29
E. KNOCKDOWN BOILERS – FLUE COLLECTOR ASSEMBLY	8	E. MAIN BURNER CHECK	30
F. KNOCKDOWN BOILERS – HYDROSTATIC TESTING	9	F. CONTROLS CHECK	30
G. KNOCKDOWN BOILERS – ASSEMBLE JACKET	9	G. PURGING AIR	30
3. VENTING	11	H. CHECK SYSTEM PRESSURE	30
A. CHIMNEY OR VENT	11	I. CLEAN THE BOILER	30
B. AUTOMATIC VENT DAMPER INSTALLATION – GENERAL	11	J. BOILER SHUT-DOWN	31
C. BOILER REMOVAL FROM COMMON VENTING SYSTEM	12	9. MAINTENANCE	35
4. BOILER PIPING	14	A. GENERAL	36
A. WATER BOILER PIPING – SINGLE BOILER	14	B. DAILY MAINTENANCE	36
B. WATER BOILER PIPING – MULTIPLE BOILERS	15	C. WEEKLY MAINTENANCE	36
C. STEAM BOILER PIPING – SINGLE BOILER	15	D. MONTHLY MAINTENANCE	36
D. STEAM BOILER INDIRECT WATER HEATER PIPING	16	E. ANNUAL MAINTENANCE	36
E. STEAM BOILER PIPING – MULTIPLE BOILERS	16	F. AS REQUIRED MAINTENANCE	37
		10. TROUBLESHOOTING	38
		11. BOILER DIMENSIONS & RATINGS	42
		12. REPAIR PARTS	44

USING THIS MANUAL

A. INSTRUCTION MANUALS

The Series 63/64™ Installation, Operation & Maintenance Manual is divided into four basic sections:

1. Preinstallation (Section 1)
2. Installation (Sections 2 through 8)
3. Start-Up (Section 9)
4. Maintenance (Section 10)

B. SPECIAL ATTENTION BOXES

Throughout this manual special attention boxes are provided to supplement the instructions and make special notice of potential hazards. The definition of each of these categories, in the judgement of PB Heat, LLC are as follows.

DANGER

Indicates a condition or hazard which will cause severe personal injury, death or major property damage.

WARNING

Indicates a condition or hazard which may cause severe personal injury, death or major property damage.

CAUTION

Indicates a condition or hazard which will or can cause minor personal injury or property damage.

NOTICE

Indicates special attention is needed, but not directly related to potential personal injury or property damage.

1. PREINSTALLATION

A. GENERAL

Series 63/64™ boilers are supplied knocked down for field assembly or completely assembled as packaged boilers. All items should be inspected for damage upon receipt and any damage reported to the trucker and wholesaler. All components should be stored in a clean dry area.

Carefully read these instructions before beginning work. Understand all aspects of the installation. Contact PB Heat sales representative or customer service for help in answering questions.

This boiler must be installed by a qualified contractor. The boiler warranty may be voided if the boiler is not installed correctly.

A hot water boiler installed above radiation level or as required by the Authority having jurisdiction, must be provided with a low water cut-off device either as part of the boiler or at the time of installation.

B. CODES & REGULATIONS

1. All work should be performed in strict accordance with the requirements of state and local regulating agencies and codes dealing with boiler installations.
2. In the absence of such local requirements the following should govern.
 - a. ASME Boiler & Pressure Vessel Code, Section IV – “Heating Boilers”
 - b. ASME Boiler & Pressure Vessel Code, Section VI – “Recommended Rules for the Care and Operation of Heating Boilers”
 - c. ANSI Z223.1/NFPA 54 – “National Fuel Gas Code”
 - d. ANSI/NFPA 70 – “National Electrical Code”
 - e. ASME CSD-1 – “Controls & Safety Devices for Automatically Fired Boilers”
 - f. ANSI/NFPA 211 – “Chimneys, Fireplaces, vents, and Solid Fuel Burning Appliances”
3. Where required by the authority having jurisdiction, the installation must conform to the Standard for *Controls and Safety Devices for Automatically Fired Boilers*, ANSI/ASME CSD-1.

C. ACCESSIBILITY CLEARANCES

The following recommendations allow for reasonable access to the boiler. Local codes or special conditions may require greater clearances.

1. For servicing the boiler provide not less than 24" from the side of the boiler where limit and level controls are mounted.

2. For servicing the burners provide not less than 24" from the front of the boiler.
3. The remaining clearances should be 6" from all sides.

D. CLEARANCES FROM COMBUSTIBLE CONSTRUCTION

Boiler Models 63-03 through 63-06

1. The design of this boiler is certified for alcove installation with the following clearances to combustible construction.
 - a. Sides: 6"
 - b. Top: 30"
 - c. Front: 18"
 - d. Rear: 6"
 - e. Single Wall Vent Pipe: 6"

Boiler Models 64-07 through 64-12

2. The design of this boiler is certified for installation with the following clearances to combustible construction. Boiler must be installed in an area large in comparison to the boiler.
 - a. Sides: 24"
 - b. Top: 30"
 - c. Front: 18"
 - d. Rear: 24"
 - e. Single Wall Vent Pipe: 6"
3. All Models
 - a. Single wall vent pipe must be at least 6" away from combustible construction.
 - b. For installation on non-combustible flooring only.

WARNING

Do not install this boiler on combustible flooring. Boiler installation on combustible flooring is a fire hazard.

- c. If it is necessary to build a non-combustible floor pad on top of an existing combustible floor, construct pad as described in the Installation of Specific Equipment Chapter of National Fuel Gas Code Handbook.

WARNING

Do not install this boiler on carpeting.

E. AIR FOR COMBUSTION AND VENTILATION

1. Adequate combustion air and ventilation air must be provided for this appliance in accordance with the section of the *National Fuel Gas Code* entitled, "Air for Combustion and Ventilation" or applicable provisions of the local building code. Subsections 2 through 8 as follows are based on the *National Fuel Gas Code* requirements.
2. **Required Combustion Air Volume:** The total required volume of indoor air is to be the sum of the required volumes for all appliances located within the space. Rooms communicating directly with the space in which the appliances are installed and through combustion air openings sized as indicated in Subsection 3 are considered part of the required volume. The required volume of indoor air is to be determined by one of two methods.

a. **Standard Method:** The minimum required volume of indoor air (room volume) shall be 50 cubic feet per 1000 BTU/Hr (4.8 m³/kW). This method is to be used if the air infiltration rate is unknown or if the rate of air infiltration is known to be greater than 0.6 air changes per hour. As an option, this method may be used if the air infiltration rate is known to be between 0.6 and 0.4 air changes per hour. If the air infiltration rate is known to be below 0.4 then the *Known Air Infiltration Rate Method* must be used. If the building in which this appliance is to be installed is unusually tight, PB Heat recommends that the air infiltration rate be determined.

b. **Known Air Infiltration Rate Method:** Where the air infiltration rate of a structure is known, the minimum required volume of indoor air for appliances other than fan assisted and for the Series 63/64™ Boiler shall be determined as follows:

$$\text{Required Volume}_{\text{other}} = \frac{21 \text{ ft}^3}{\text{ACH}} \left(\frac{I_{\text{other}}}{1000 \text{ Btu/hr}} \right)$$

where:

I_{other} = Input of appliances other than fan assisted in Btu/hr

ACH = air change per hour (percent of the volume of the space exchanged per hour, expressed as a decimal)

$$\text{Required Volume}_{\text{fan}} = \frac{15 \text{ ft}^3}{\text{ACH}} \left(\frac{I_{\text{fan}}}{1000 \text{ Btu/hr}} \right)$$

For fan assisted appliances, calculate the required volume of air using the following equation:

I_{fan} = Input of the fan assisted appliances in Btu/hr

Note: These calculations are not to be used for infiltration rates greater than 0.60 ACH.

3. **Indoor Air Opening Size and Location:** Openings connecting indoor spaces shall be sized and located as follows:

- a. **Combining spaces on the same floor:** Provide two permanent openings communicating with additional spaces that have a minimum free area of 1 in² per 1000 Btu/hr (22 cm² per 1000 W) of the total input rating of all gas fired equipment but not less than 100 in² (645 cm²). One opening is to begin within 12 inches (305 mm) from the top of the space and the other is to begin within 12 inches (305 mm) from the floor. The minimum dimension of either of these openings shall be 3 inches (76 mm). See Figure 1.1 for an illustration of this arrangement.

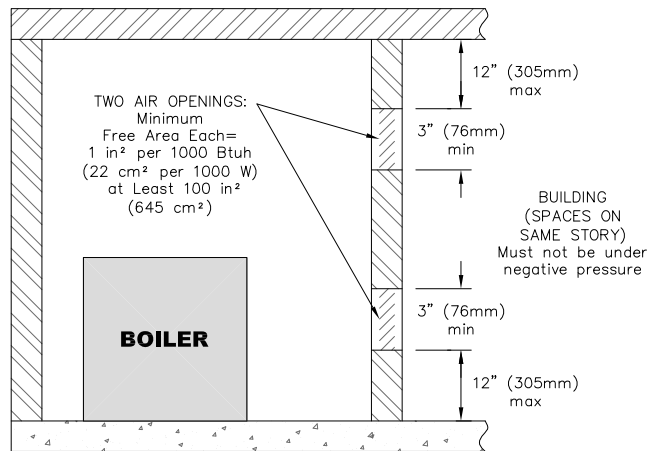

Figure 1.1: Air Openings – All Air from Indoors on the Same Floor

- b. **Combining spaces on different floors:** Provide one or more permanent openings communicating with additional spaces that have a total minimum free area of 2 in² per 1000 Btu/hr (44 cm² per 1000 W) of total input rating of all equipment. See Figure 1.2 for an illustration of this arrangement.

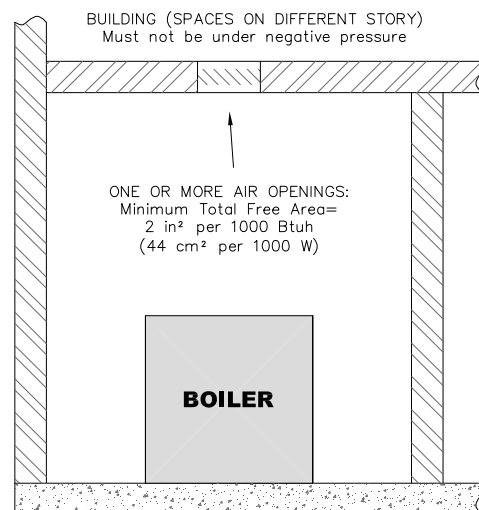

Figure 1.2: Air Openings – All Air from Indoors on Different Floors

4. **Outdoor Combustion Air:** Outdoor combustion air is to be provided through one or two permanent openings. The minimum dimension of these air openings is 3 inches (76 mm).

a. **Two Permanent Opening Method:** Provide two permanent openings. One opening is to begin within 12 inches (305 mm) of the top of the space and the other is to begin within 12 inches (305 mm) of the floor. The openings are to communicate directly or by ducts with the outdoors or with spaces that freely communicate with the outdoors. The size of the openings shall be determined as follows:

i. Where communicating directly or through vertical ducts with the outdoors each opening shall have a minimum free area of 1 in² per 4000 Btu/hr (22 cm² per 4000 W) of total input rating for all equipment in the space. See Figure 1.3 for openings directly communicating with the outdoors or Figure 1.4 for openings connected by ducts to the outdoors.

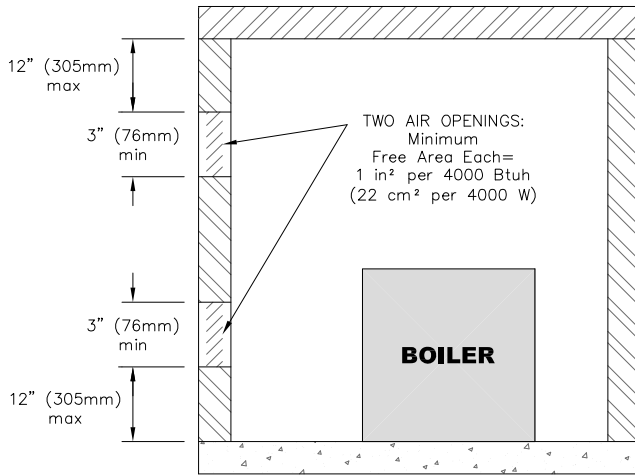

Figure 1.3: Air Openings - All Air Directly from Outdoors

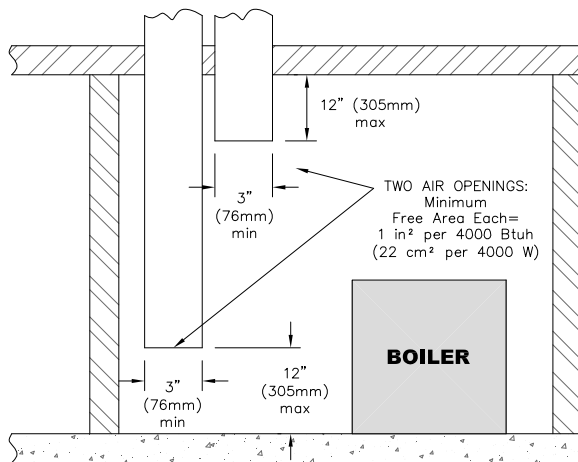

Figure 1.4: Air Openings - All Air from Outdoors through Vertical Ducts

ii. Where communicating with the outdoors through horizontal ducts, each opening shall have a minimum free area of 1 in² per 2000 Btu/hr (22 cm² per 2000 W) of total rated input for all appliances in the space. See Figure 1.5.

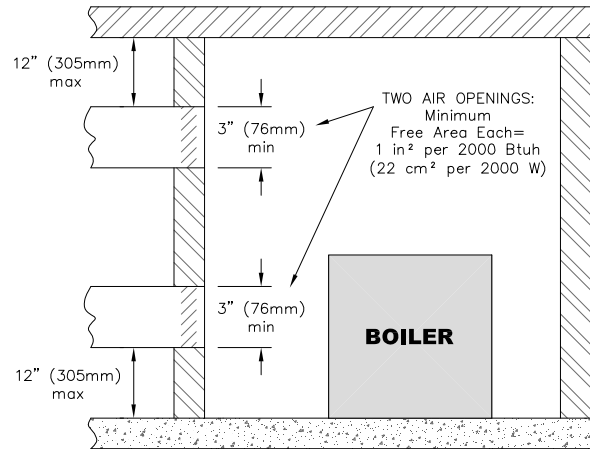

Figure 1.5: Air Openings - All Air from Outdoors through Horizontal Ducts

b. **One Permanent Opening Method:** Provide one permanent opening beginning within 12 inches (305 mm) of the top of the space. The opening shall communicate directly with the outdoors, communicate through a vertical or horizontal duct, or communicate with a space that freely communicates with the outdoors. The opening shall have a minimum free area of 1 in² per 3000 Btu/hr of total rated input for all appliances in the space and not less than the sum of the cross-sectional areas of all vent connectors in the space. The gas-fired equipment shall have clearances of at least 1 inch (25 mm) from the sides and back and 6 inches (150 mm) from the front of the appliance. See Figure 1.6 for this arrangement.

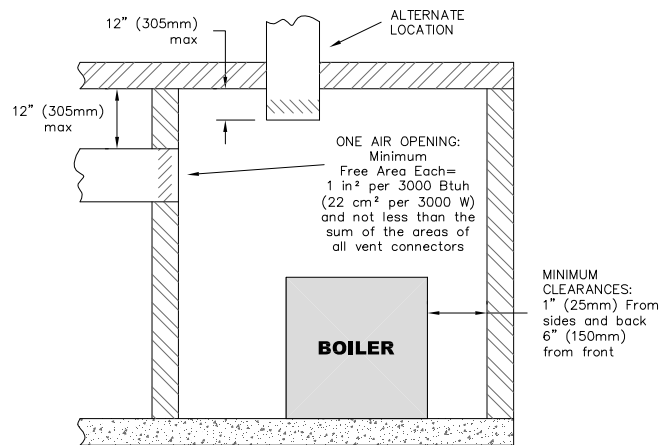

Figure 1.6: Air Openings - All Air from Outdoors through One Opening

5. Combination Indoor and Outdoor Combustion Air: If the required volume of indoor air exceeds the available indoor air volume, outdoor air openings or ducts may be used to supplement the available indoor air provided:

- a. The size and location of the indoor openings comply with Subsection 3.
- b. The outdoor openings are to be located in accordance with Subsection 4.
- c. The size of the outdoor openings are to be sized as follows:

$$A_{req} = A_{full} \times \left(1 - \frac{V_{avail}}{V_{req}} \right)$$

where:

- A_{req} = minimum area of outdoor openings.
- A_{full} = full size of outdoor openings calculated in accordance with Subsection 4.
- V_{avail} = available indoor air volume
- V_{req} = required indoor air volume

6. Engineered Installations: Engineered combustion air installations shall provide an adequate supply of combustion, ventilation, and dilution air and shall be approved by the authority having jurisdiction.

7. Mechanical Combustion Air Supply:

- a. In installations where all combustion air is provided by a mechanical air supply system, the combustion air shall be supplied from the outdoors at the minimum rate of 0.35 ft³/min per 1000 Btu/hr (0.034 m³/min per 1000 W) of the total rated input of all appliances in the space.
- b. In installations where exhaust fans are installed, additional air shall be provided to replace the exhaust air.
- c. Each of the appliances served shall be interlocked to the mechanical air supply to prevent main burner operation when the mechanical air supply system is not in operation.
- d. In buildings where the combustion air is provided by the mechanical ventilation system, the system shall provide the specified combustion air rate in addition to the required ventilation air.

8. Louvers & Grills:

- a. The required size of openings for combustion, ventilation, and dilution air shall be based on the net free area of each opening.
 - i. Where the free area through a louver or grille is known, it shall be used in calculating the opening size required to provide the free area specified.

- ii. Where the free area through a louver or grille is not known, it shall be assumed that wooden louvers will have 25% free area and metal louvers and grilles will have 75% free area.

- iii. Nonmotorized dampers shall be fixed in the open position.

- b. Motorized dampers shall be interlocked with the equipment so that they are proven in the full open position prior to ignition and during operation of the main burner.

- i. The interlock shall prevent the main burner from igniting if the damper fails to open during burner startup.

- ii. The interlock shall shut down the burner if the damper closes during burner operation.

9. Combustion Air Ducts

- a. Ducts shall be constructed of galvanized steel or an equivalent corrosion-resistant material.

- b. Ducts shall terminate in an unobstructed space, allowing free movement of combustion air to the appliances.

- c. Ducts shall serve a single space.

- d. Ducts shall not serve both upper and lower combustion air openings where both such openings are used. The separation between ducts serving upper and lower combustion air openings shall be maintained to the source of combustion air.

- e. Ducts shall not be screened where terminating in an attic space.

- f. Horizontal upper combustion air ducts shall not slope downward toward the source of the combustion air.

- g. The remaining space surrounding a chimney liner, gas vent, special gas vent, or plastic piping installed within a masonry, metal, or factory built chimney shall not be used to supply combustion air.

- h. Combustion air intake openings located on the exterior of buildings shall have the lowest side of the combustion air intake opening at least 12 inches (305 mm) above grade.

WARNING

Liquefied Petroleum (LP) is heavier than air and may collect or “pool” in a low area in the event of a leak from defective equipment. This gas may then ignite, resulting in a fire or explosion.

F. INSTALLATION SURVEY

For new and existing installations, a Water Installation Survey or a Steam Installation Survey is available from PB Heat, LLC. The surveys will provide information on how the boiler works with your specific system and will provide an overview of boiler system operation in general.

You can also use this survey to locate system problems which will have to be corrected. To obtain copies of these Surveys, contact your PB Heat representative or download them from PeerlessBoilers.com.

G. PLANNING THE LAYOUT

Prepare sketches and notes of the layout to minimize the possibility of interferences with new or existing equipment, piping, venting and wiring.

2. BOILER PLACEMENT & ASSEMBLY

A. PACKAGED BOILER

1. Remove the crate top and sides and remove any loose cartons.
2. Lift the boiler from the crate pallet. Move the boiler to the location determined in Chapter 1: Pre-installation.

⚠ NOTICE

Be careful not to damage the burner tray when removing the boiler from the pallet. If necessary, remove the burner tray before moving the boiler.

3. Proceed to Chapter 3: Piping the Boiler.

B. KNOCKDOWN BOILERS - SPLIT BLOCK ASSEMBLY MODELS 64-07 TO 64-12

1. The boiler sections and base on Model 63-03 to 63-06 are factory assembled. If the boiler is 63-03 through 63-06 begin assembly as described in step 2.C, Knockdown Boilers: Assembled Blocks.
2. Move each block of cast iron sections off of the shipping pallets and support them as shown in Figure 2.1.

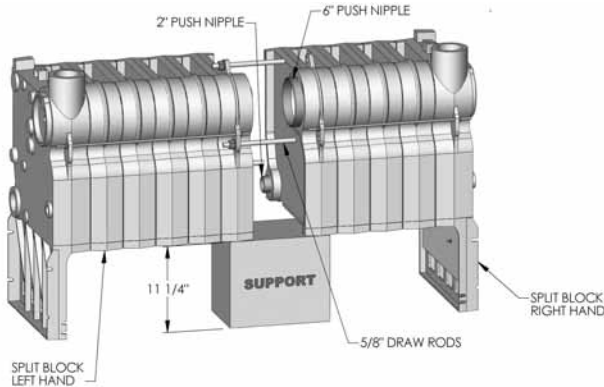

Figure 2.1: Block Assembly

3. Clean nipple ports using a wire brush. Make certain there are no burrs around the outside edge of the ports. If necessary, remove any burrs on the edges using a round file (be careful not to score the nipple port).
4. Spread a thin coat of TFE TITE Nipple Sealant in the nipple ports.

⚠ NOTICE

Never apply nipple sealer on the nipples. Apply only in nipple ports.

5. Insert the push nipples into the nipple ports of one of the split block ends. Make sure the nipples are clean and free of burrs. Use a block of wood to protect the surface of the nipple while setting the nipple into the nipple port with a hammer. Assure that the nipple is firmly seated in the nipple port before proceeding.

⚠ NOTICE

Never hit the nipple directly with a hammer. This will damage the nipple and cause leaks.

⚠ NOTICE

If the nipple is not fully seated in the nipple port, damage to the nipple may occur when the sections are drawn together.

6. Apply silicone sealant to the rope groove to hold the rope in place during assembly. Press 1/2" diameter rope into the rope groove.
7. Assure the nipples are perpendicular to the sections and that the blocks are aligned properly.
8. Insert draw rods through the lugs provided on the mating intermediate sections. Use 5/8" draw rods as shown in Figure 2.1.
9. Before starting to draw the sections together, apply lubricating oil to the threads.
10. Tighten the hex nuts and draw the boiler sections together evenly until the small pads on each of the mating sections are in contact:
 - Periodically measure the gap at all four corners of the section to make sure the sections are drawing together evenly – **gaps measured at all four corners should not vary more than 1/8"**. Turn wrench no more than 3-4 times before moving to the next nut (this equates to about an 1/8" draw-up).
 - Using similar torque on each nut, gradually increase the torque as the sections are drawn closer together. **Maximum allowable torque on the draw rod nuts is 80 foot-pounds.** Typically only 30 to 60 foot-pounds is required to pull together evenly drawn sections.
 - If one corner resists moving, loosen the draw rods on the other corners to help pull the subject corner into proper alignment.

BOILER PLACEMENT & ASSEMBLY

11. If the sections do not draw together using the torque specified above, the block must be separated and the nipples replaced before reassembly is attempted.
12. The sections may alternatively be drawn together using long 5/8" rods along with cast iron washers through the nipple ports. Two large cast iron washers (51163), two small cast iron washers (51165) and two long 5/8" NPT rods are required (not provided). Do not attempt to draw sections together without the cast iron washers.

C. KNOCKDOWN BOILERS: ASSEMBLED BLOCKS

1. If shipping pallet is still attached, move the assembled block off of the pallet.
2. Move the assembled block to the location determined in Chapter 1: Pre-installation. The location should be on a level foundation as near to the chimney as possible and centralized with respect to the heating system.
3. Attach the base front/rear insulated panels to the cast iron block assembly as shown in Figure 2.2 using 3/8" carriage bolts and 3/8" hex nuts.
4. Attach the base lower rear panel to the cast iron block assembly using 3/8" carriage bolts and hex nuts.

D. KNOCKDOWN BOILERS: CONTROL & MANIFOLD ASSEMBLY

1. Remove the burner tray assembly from the burner and controls carton.
2. Check burners to assure that they are seated correctly in the burner tray rear support.
3. For Series 64™ boilers, assemble the 90° elbow and return bend to the manifold assembly.
4. Remove the gas valve manifold components from the burner tray and controls carton and connect them to the burner manifold. Refer to Figure 5.2 through 5.4 in Section 5 for the specific Gas Train Manifold Configuration.

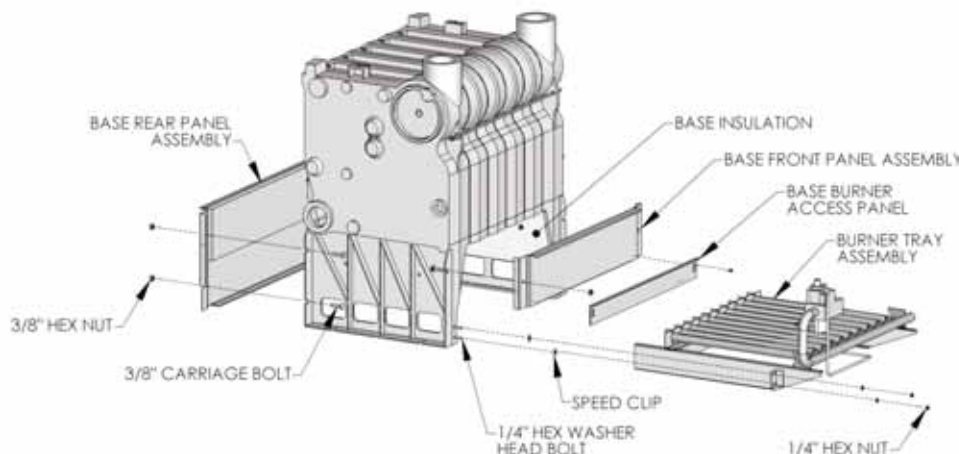

Figure 2.2: Base Panel Attachment

5. Slide the burner tray under the cast iron block assembly and attach to the end sections using the 1/4" carriage bolts and nuts provided. (See Figure 2.2).
6. Attach the base burner access panel to the base front panel assembly with two #10 x 1/2" sheet metal screws (See Figure 2.2).

E. KNOCKDOWN BOILERS: FLUE COLLECTOR ASSEMBLY

1. Remove the flue collector and ceramic blanket strip insulation from burner and controls carton.
2. Lay the ceramic blanket strip on top of the boiler using care not to block any flue passageways.
3. Insert the two 1/4"-20 carriage bolts provided with boiler into the lugs on top of the boiler end sections as shown in Figure 2.3.

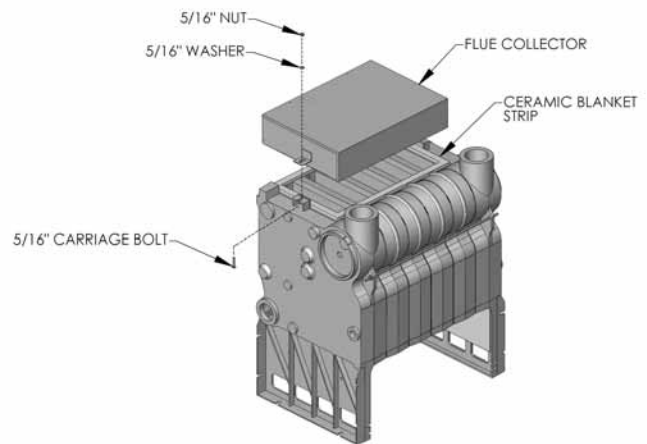

Figure 2.3: Flue Collector Attachment

4. Attach the flue collector to the bolts with the flat washers and hex nuts provided. Tighten the nuts snugly.

F. KNOCKDOWN BOILER: HYDROSTATIC TESTING

1. Install the pressure gauge and drain valve in the right hand end section.
2. Install a water supply line with a shut-off valve in the right hand end section.
3. Install an air vent valve on the boiler relief valve connection.
4. Plug all open tappings in the boiler.
5. Fill the boiler with water, venting air from the top of the unit as the water level rises.
6. Pressurize the boiler from 75 to 85 psig. Do not exceed 85 psig.
7. Maintain pressure while inspecting the boiler thoroughly for leaks.
8. After inspection is complete, drain the boiler and remove plugs from tappings that are to be used.

G. KNOCKDOWN BOILER: ASSEMBLE JACKET

1. The Series 63™ boilers employ a wrap-around style jacket while the Series 64™ boilers use an individual back panel.
2. Align the clearance holes on the side panels with the mounting holes in the base front & back plates and attach with #10 x 1/2" sheet metal screws.
3. **Wrap-Around Jacket:** Bend the side jacket panels at the perforations to form the back of the jacket. The left side should overlap the right for proper attachment. Connect the two panels with three #10 x 1/2" sheet metal screws. See Figure 2.4.

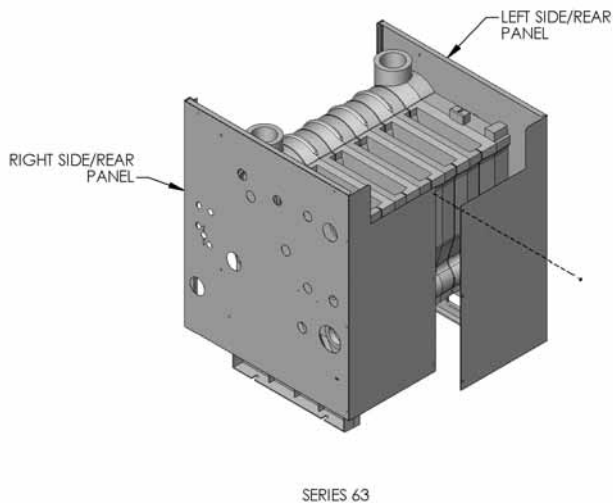

Figure 2.4: Jacket Assembly, Series 63™ Boilers

4. **Back Panel Jacket:** Position the back jacket panel inside the flange of the side jacket panels and attach it with six #10 x 1/2" sheet metal screws. See Figure 2.5.

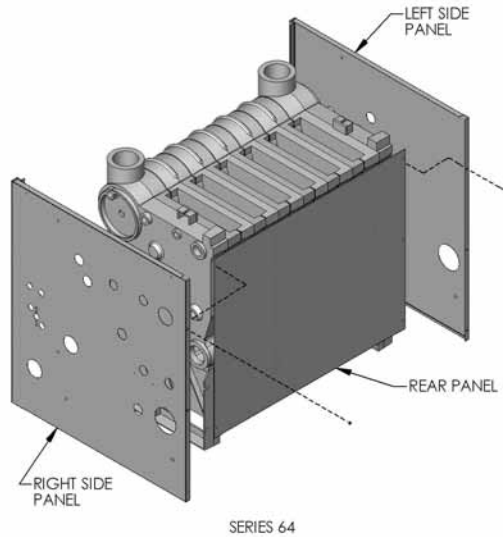

Figure 2.5: Jacket Assembly, Series 64™ Boilers

5. Position the Inner Front Panel between the side panels and align the mounting holes on the side flanges with the clearance holes on the side panels. Attach with four #10 x 1/2" sheet metal screws provided. See Figure 2.6.

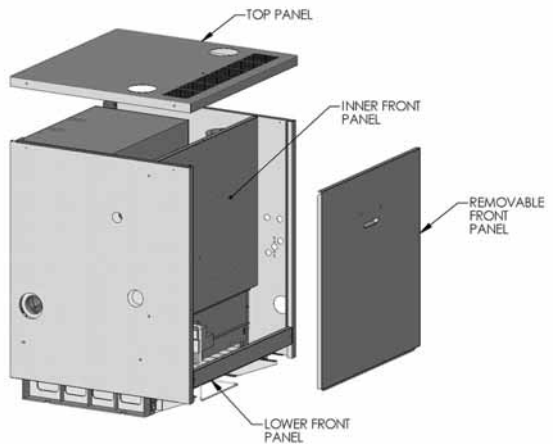

Figure 2.6: Jacket Panel Attachment

6. Attach the Lower Front Panel to the bottom front of the side Jacket Panels with two #10 x 1/2" sheet metal screws. See Figure 2.6.

7. Attach the Draft Hood to the Flue Collector using #10 x 1/2" sheet metal screws provided. Refer to Figure 2.7.

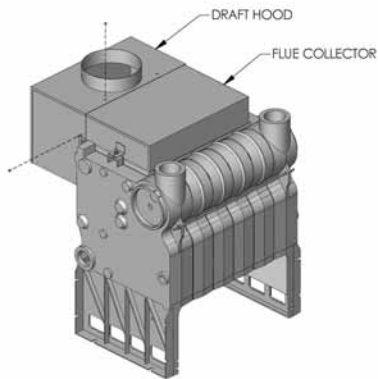

Figure 2.7: Draft Hood Attachment

8. Position the Top Jacket Panel so that the flanges overlap the Side Jacket Panels and the air louvers are at the front of the boiler. Attach with six #10 x 1/2" sheet metal screws. See Figure 2.6.
9. Remove the following data plates or labels from the manila envelope that contains the Instruction Manual:
 - Boiler Rating Label
 - Lighting/Operating Instruction Label
 - Wiring Diagram Label

Attach labels as shown in Figure 2.8.

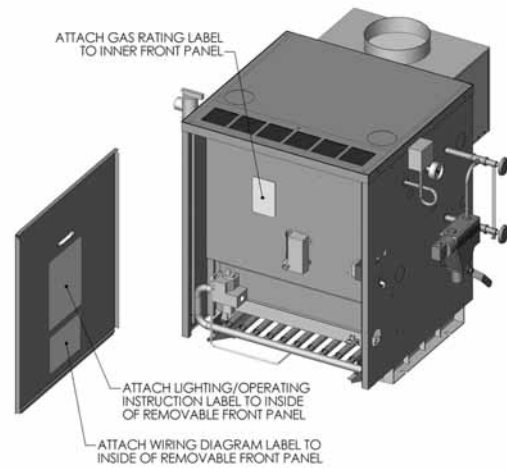

Figure 2.8: Label & Rating Plate Locations

10. Insert the top edge of the Front Jacket Panel beneath front flange of the Top Jacket Panel and against the top of the Lower Front Panel.

3. VENTING

A. CHIMNEY OR VENT

1. Inspect the existing chimney or vent system. Make sure it is in good condition. Inspect chimney liner and repair or replace if necessary.
2. The vent system and installation must be in accordance with Venting of Equipment chapter of the current edition of the *National Fuel Gas Code*, ANSI Z223.1/NFPA 54, or applicable provisions of the local building codes.
3. Chimney/Vent Operation: The vent system must be sized and installed to provide the draft needed to remove all combustion products. If the vent system does not provide enough draft, combustion products will spill into the building from the draft hood relief opening. If spillage of combustion products occurs, check the vent system, the combustion and ventilation openings and make sure the boiler room is never under negative pressure.

WARNING

Failure to provide adequate venting can result in severe personal injury or death.

4. Vent Connection to Boiler:
 - a. Support the weight of the vent system independently of the boiler draft hood. The draft hood is not designed to carry structural loading.
 - b. Provide support of the vent connector (breaching) at maximum 12 foot intervals to prevent sagging and to provide a minimum upward slope of 1/4" per foot.

- c. Do not connect the vent for this boiler into any vent system which operates with positive pressure.
- d. The vent connector must be single wall steel or Type B double wall vent pipe. The vent connector must be Type B double wall if it is located in or passes through cold areas. The vent connector must extend into, but not beyond, the inside wall of the chimney.

B. AUTOMATIC VENT DAMPER INSTALLATION – GENERAL

1. Do not use one vent damper to control two or more heating appliances. See Figure 3.1.
2. Follow these and the installation instructions included with the vent damper. Observe the cautions and warnings that accompany all instructions.
3. Provide minimum 6 inch (152 mm) clearance between automatic vent damper and combustible construction. Increase clearance if required by vent damper manufacturer's instructions. Provide adequate space for vent damper access and service.
4. The automatic vent damper can be mounted directly onto the draft hood outlet or in vent piping close to the boiler.

See Figure 3.2 for installation with vent damper mounted in vertical position. See Figure 3.3 for installation with vent damper mounted in horizontal position. Mount the unit to avoid excessive heat on the operator or condensation drips into the operator.

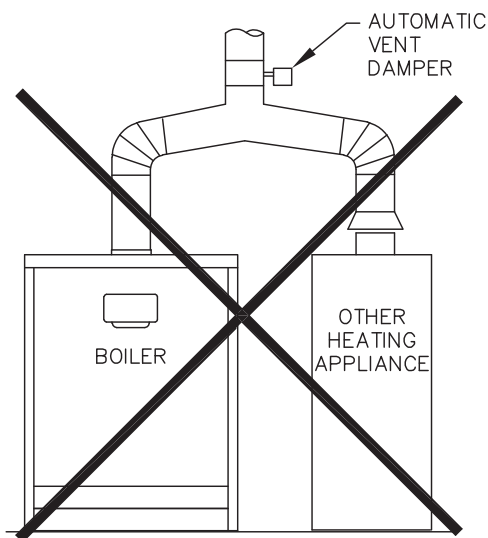

INCORRECT

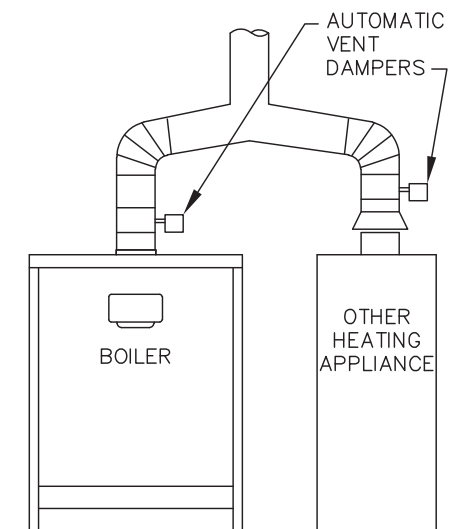

CORRECT

Figure 3.1: Venting Multiple Appliances

- a. Orient the vent damper operator to facilitate connection of the vent damper harness to knockout on right side of boiler.
- b. Orient vent damper direction arrow in direction of vent gas flow. Direction arrow must be visible from front of boiler.

CAUTION

Damper must be in open position when main burners are operating.

Le registre doit être en position ouverte lorsque le brûleur principal de l'appareil fonctionne.

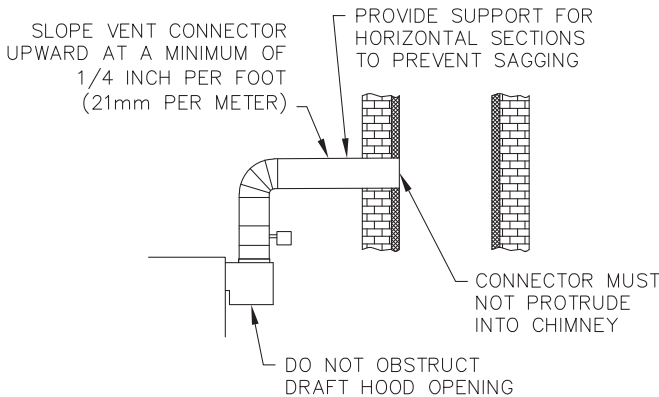

Figure 3.2: Venting with Vent Damper in Vertical Position

C. BOILER REMOVAL FROM COMMON VENTING SYSTEM

When an existing boiler is removed from a common venting system, the common venting system is likely to be too large for proper venting of the remaining appliances connected to it.

At the time of removal of an existing boiler, follow these steps with each appliance remaining connected to the common venting system placed in operation, while the other appliances remaining connected to the common venting system are not in operation:

Au moment de retirer une chaudière existante, il est important de suivre les étapes suivantes pour chaque appareil raccordé au système d'évacuation commun qui sont en service, alors que les autres appareils demeurant raccordés au système d'évacuation commun ne sont pas en service :

- a. Seal any unused openings in the common venting system.
Sceller toute ouverture du système d'évacuation commun non utilisée.
- b. Visually inspect the venting system for proper size and horizontal pitch and determine there is no blockage or restriction, leakage, corrosion and other deficiencies which could cause an unsafe condition.

Effectuer un contrôle visuel du système d'évacuation pour vérifier la taille et la pente horizontale et s'assurer qu'il n'existe aucun blocage ou obstruction, fuite, corrosion ni tout autre problème pouvant menacer la sécurité.

- c. Insofar as is practical, close all building doors and windows and all doors between the space in which the appliances remaining connected to the common venting system are located and other spaces of the building. Turn on any clothes dryers and any appliance not connected to common venting system. Turn on any exhaust fans, such as range hoods and bathroom exhausts, so they will operate at maximum speed. Do not operate a summer exhaust fan. Close fireplace dampers.

Dans la mesure du possible, fermer toutes les portes et fenêtres de l'immeuble ainsi que toutes les portes entre l'espace dans lequel les appareils qui demeurent raccordés au système d'évacuation commun se trouvent et le reste de l'immeuble. Mettre en marche les sècheuses et tout autre appareil non raccordé au système d'évacuation commun. Mettre en marche tous les ventilateurs aspirant, tels que les hottes de cuisinière et les ventilateurs de salle de bain, en les faisant fonctionner à vitesse maximum. Ne pas faire fonctionner les ventilateurs aspirant d'été. Fermer les registres de foyers.

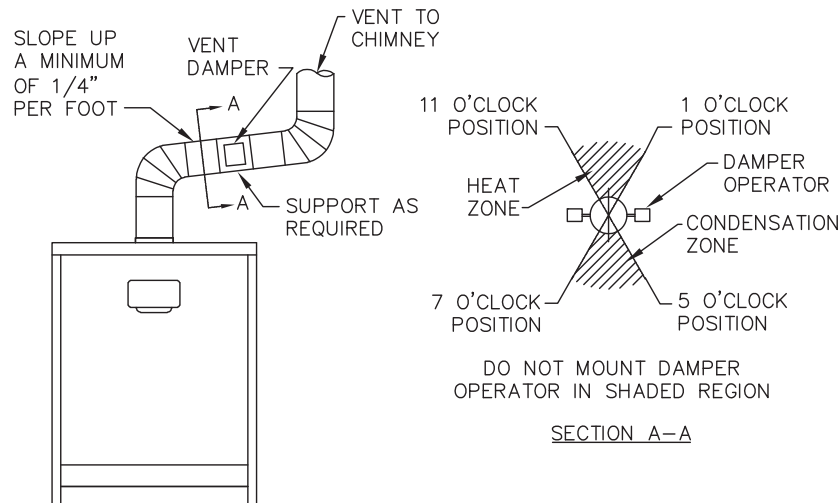

Figure 3.3: Venting with Vent Damper in Horizontal Position

- d. Place in operation the appliance being inspected. Follow the lighting instructions. Adjust thermostat so appliance will operate continuously.
Mettre en service l'appareil à inspecter. Suivre les instructions concernant l'allumage. Régler le thermostat afin que l'appareil fonctionne sans arrêt.
- e. Test for spillage at the draft hood relief opening after 5 minutes of main burner operation. Use the flame of a match or candle, or smoke from a cigarette, cigar, or pipe.
Vérifier toute fuite à l'orifice de décharge du coupe-tirage après que le brûleur ait fonctionné pendant 5 minutes. Utiliser la flamme d'une allumette ou d'une chandelle ou encore la fumée d'une cigarette, d'un cigare ou d'une pipe.
- f. After it has been determined that each appliance remaining connected to the common venting system properly vents when tested as outlined above, return doors, windows, exhaust fans, fireplace dampers and any other gas-burning appliance to their previous conditions of use.
Après avoir établi que les résidus de combustion de chaque appareil qui demeure raccordé au système commun sont adéquatement évacués lorsque soumis au test décrit ci-dessus, remettre en place les portes, fenêtres, portes intérieures, ventilateurs aspirants, registres de foyer et appareils fonctionnant au gaz.
- g. Any improper operation of the common venting system should be corrected so that the installation conforms with the current edition of the *National Fuel Gas Code*, ANSI Z223.1/NFPA 54 and/or CAN/CSA B149.1, *Natural Gas and Propane Installation Code*. When resizing any portion of the common venting system, the common venting system should be resized to approach the minimum size as determined using the appropriate tables in the *National Fuel Gas Code*, ANSI Z223.1/NFPA 54 and/or CAN/CSA B149.1, *Natural Gas and Propane Installation Code*.
Tout fonctionnement inadéquat du système d'évacuation commun doit être corrigé de manière à respecter les normes du **National Fuel Gas Code**, ANSI Z223.1/NFPA 54 et/ou des Codes d'installation CAN/ACG B149. Lorsqu'il est nécessaire de modifier les dimensions de toute portion du système d'évacuation commun, ces dernières doivent être modifiées de manière à respecter les dimensions minimums indiquées dans les tableaux du chapitre « Sizing of Category I Venting Systems » du **National Fuel Gas Code**, ANSI Z223.1/NFPA 54 ou des Codes d'installation CAN/ACG B149.

4. BOILER PIPING

A. WATER BOILER PIPING – SINGLE BOILER

1. Refer to the *PB Heat Water Installation Survey and Hydronics Institute Residential Hydronic Heating Installation Design Guide*.
2. Figure 4.1 shows typical supply and return piping for a boiler system. If the system expansion tank is located on the boiler loop, it should be located on the supply side of the boiler with the system circulator pumping away from the expansion tank connection.

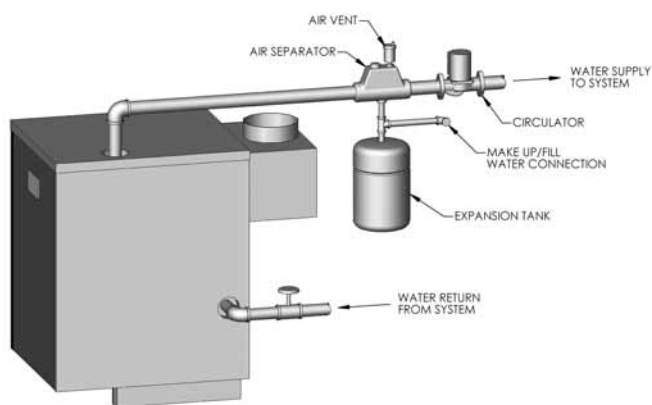

Figure 4.1

3. If the boiler is piped in a secondary loop separate from the system expansion tank, the boiler circulator should be located on the return side of the boiler pumping away from the common piping.
4. Return water should not reach the boiler return connection at less than 130°F under normal operating conditions. If the system return temperature is expected to be below 130°F the boiler should be piped in a secondary loop with a bypass arrangement to assure water returning to the boiler is above 130°F. For more information on bypass piping consult the *PB Heat Water Installation Survey*.
5. If the boiler and distribution system is used in conjunction with a refrigeration system, pipe the chilled medium in parallel with the boiler and provide isolation valves to prevent chilled water from entering the boiler. See Figure 4.2.
6. If the boiler is connected to a heating coil in a forced air combination heating and cooling system, install flow control valves to prevent gravity circulation of the boiler water during cooling cycles.
7. A hot water boiler installed above radiation level or as required by the Authority having jurisdiction, must be provided with a low water cut-off device either as part of the boiler or at the time of installation.

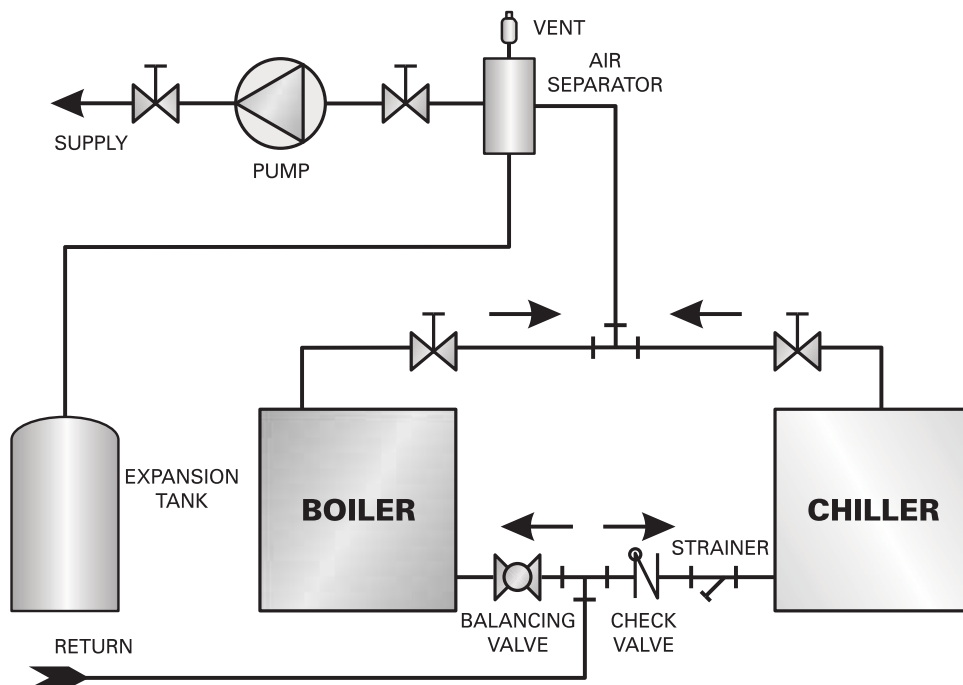

Figure 4.2: Piping to Isolate Boiler from Chilled Medium on Chiller Systems

B. WATER BOILER PIPING – MULTIPLE BOILERS

Refer to the *PB Heat Water Installation Survey and Hydronics Institute Residential Hydronic Heating Installation Design Guide* for guidance on multiple boiler installations.

C. STEAM BOILER PIPING – SINGLE BOILERS

1. Refer to the *PB Heat Steam Installation Survey and Hydronics Institute Residential Hydronic Heating Installation Design Guide* for guidance.
2. Install steam supply pipes as shown in Figure 4.3 for Model 63-03 to 64-07 and Figure 4.4 for Model 64-08 to 64-12. The minimum quantity and size of supply pipes are indicated in Table 4.1.

Use Threaded Fittings for Manifold Piping

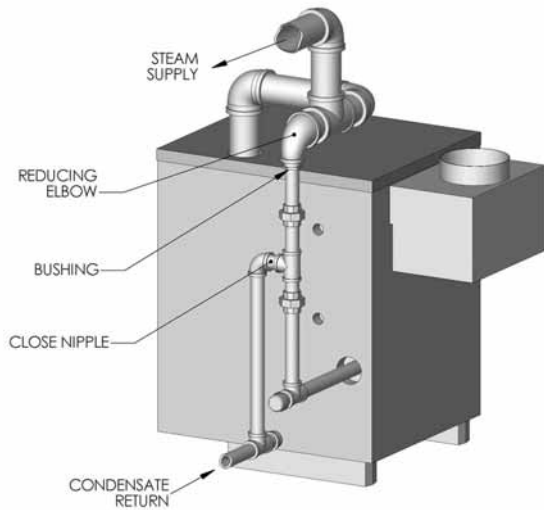

Figure 4.3: Steam Piping – Single Supply Connection

⚠ NOTICE

Use swing joints to attach to the header to avoid damage to the boiler due to thermal expansion and contraction of steam header pipe.

3. Pipe the steam header a minimum of 24" above the normal water line using swing joints to attach the risers into the steam header.

Use Threaded Fittings for Manifold Piping

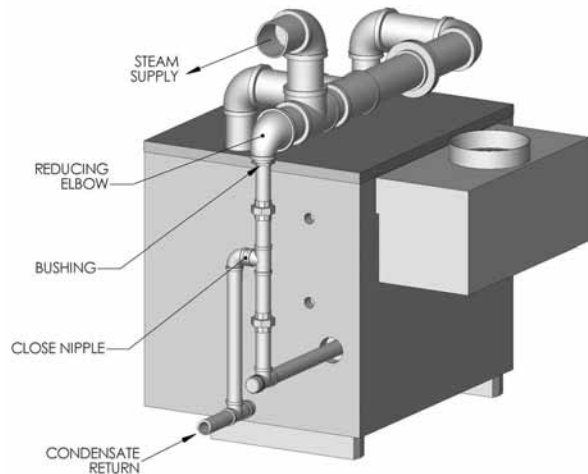

Figure 4.4: Steam Piping – Dual Supply Connections

⚠ NOTICE

- Do not use bushings or concentric reducers in the horizontal header piping. This will prevent water from dropping into the equalizer and cause water carryover into the steam piping.
- Do not reduce the size or number of steam supply risers below the minimum shown in Table 4.1. Insufficient or undersized risers can cause damage to the boiler.
- Do not use a bullhead tee to provide steam supply to the system. This will cause water carryover into the steam piping.

4. Use threaded fittings for manifold piping to provide flexibility for thermal expansion.
5. Connect the equalizing line as shown in Figure 4.3 or 4.4 assuring that the reducing elbow is facing down and that any bushings are vertical to prevent water build-up in the steam header.

- The use of a Hartford Loop in all installations is recommended to ensure reliability of the system. A check is required on the pump discharge of all pumped return systems.
- On pumped return systems, install a globe valve after the pump to allow throttling of the pump discharge. The pressure downstream of the boiler cock should be no more than 5 psig above the boiler operating pressure.

NOTICE

Always locate the steam supply take-off of the main header between the equalizer and the last boiler supply riser. Locating the steam supply between the risers will cause a bullhead tee and cause water carryover into the system.

- Pipe the Hartford Loop such that the top of the close nipple is 2 to 4 inches below the boiler normal water line.
- If the boiler feed pump discharge piping is elevated at any point above the boiler water line, install spring-loaded check valves at both the pump discharge and at the connection to the boiler.

Table 4.1: Steam Supply and Header Pipe Sizing

Boiler Model	Number of Supply Connections	Supply Size (NPS)	Header Size (NPS)	Equalizer Size (NPS)	Evaporation Rate (GPM)
63-03L	1	2	2	1-1/4	0.11
63-03	1	2	2	1-1/4	0.15
63-04L	1	2-1/2	2-1/2	1-1/4	0.19
	2*	2*			
63-04	1	2-1/2	2-1/2	1-1/4	0.23
	2*	2*			
63-05L	1	3	3	1-1/4	0.27
	2*	2*			
63-05	1	3	3	1-1/4	0.31
	2*	2*			
63-06	1	3	3	1-1/4	0.37
	2*	2-1/2*			
64-07	1	3	3	1-1/2	0.45
	2*	2-1/2*			
64-08	2	2-1/2	4	1-1/2	0.52
64-09	2	3	4	1-1/2	0.60
64-10	2	3	4	1-1/2	0.67
64-11	2	3	4	1-1/2	0.75
64-12	2	3	4	1-1/2	0.82

*Dual supplies may be used in lieu of larger single supply on 63-04L through 64-07 as indicated.

D. STEAM BOILER INDIRECT WATER HEATER PIPING

- See Figure 4.5 for typical installation.
- Install Boiler Water Temperature Limit Control in 1" Tee on supply connection (same side of boiler as low water cut-off). Set Limit at 160°F to avoid steam generation during periods when only the domestic water is calling for heat.
- Install circulator and strainer in supply piping. Install check valve to prevent gravity circulation.

NOTICE

Maintain water level near normal water line to avoid steam generation during periods when only the domestic water is calling for heat.

Tank performance reduced when supplied by steam boiler.

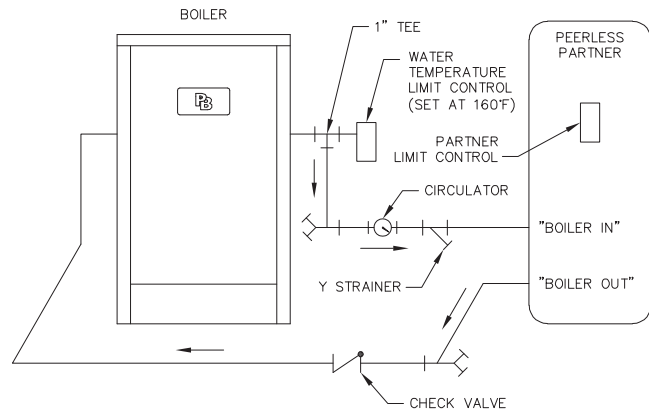

Figure 4.5: Typical Steam Boiler Indirect Water Heater Piping

E. STEAM BOILER PIPING - MULTIPLE BOILERS

Refer to the *PB Heat Steam Installation Survey and Hydronics Institute Residential Hydronic Heating Installation Design Guide* for guidance on multiple boiler installations.

5. FUEL PIPING

A. INSTALLATION

1. Pipe gas to the boiler in accordance with local codes. In the absence of local regulations refer to the *National Fuel Gas Code*, ANSI Z223.1/NFPA 54.
2. Size and install the gas supply piping to provide a supply of gas sufficient to meet the maximum demand of all appliances without excessive pressure drop.

3. The rate of gas to be provided to the boiler can be determined by:

$$CFH = \frac{\text{Boiler Input (BTU/HR)}}{\text{Gas Heating Value (BTU/FT}^3\text{)}}$$

Obtain the gas heating value of the gas from the gas supplier. As an alternative use Table 5.1.

4. Table 5.2 shows the maximum flow capacity of several pipe sizes based on 0.3 inches of water pressure drop. These values are based on a specific gravity of 0.60. Apply the factors indicated in Table 5.3 for gas with specific gravity other than 0.60 to obtain corrected capacities.

Table 5.2: Maximum Capacity of Pipe in CFH for a Pressure Drop of 0.3" of Water

Based on Specific Gravity of 0.60					
Pipe Length (Feet)	1/2" Pipe	3/4" Pipe	1" Pipe	1-1/4" Pipe	1-1/2" Pipe
10	132	278	520	1,050	1,600
20	92	190	350	730	1,100
30	73	152	285	590	890
40	63	130	245	500	760
50	56	115	215	440	670
60	50	105	195	400	610

Table 5.3: Maximum Capacity Correction Factors Specific Gravity other than 0.60

Specific Gravity	0.50	0.55	0.60	0.65	0.70	0.75
Correction Factor	1.10	1.04	1.00	0.96	0.93	0.90
Specific Gravity	0.80	0.85	0.90	1.00	1.10	1.20
Correction Factor	0.87	0.84	0.82	0.78	0.74	0.71
Specific Gravity	1.30	1.40	1.50	1.60	1.70	1.80
Correction Factor	0.68	0.66	0.63	0.61	0.59	0.58

B. OPERATION

1. Assure that the gas supply pressure to the boiler is regulated to 1/2 psi or less (approx. 13.5 inches of water).
2. Install a service valve, sediment trap, and ground joint union at the gas supply connection as shown in Figure 5.1.

CAUTION

Use a pipe joint sealing compound that is resistant to the action of liquefied petroleum gas. A non-resistant compound may lose sealing ability in the presence of this gas, resulting in a gas leak and fire or explosion potential.

Table 5.1: Gas Input & Valve Inlet

Model	Gas Input ¹ (CFH)		Gas Valve Inlet ² (NPT)	
	Nat. Gas	LP Gas	Nat. Gas	LP Gas
63-03L	88.5	35.4	1/2"	1/2"
63-03	118.0	47.2		
63-04L	147.5	59.0		
63-04	177.0	70.8	3/4"	3/4"
63-05L	206.5	82.6		
63-05	236.0	94.4		
63-06	287.5	115.0		
64-07	345.0	138.0		
64-08	399.0	159.6		
64-09	460.0	184.0	1"	3/4"
64-10	517.5	207.0		
64-11	575.0	230.0		
64-12	632.5	253.0		

1. Natural Gas Based on 1000 Btu./Cubic Foot, LP Gas Based on 2500 Btu./Cubic Foot.
2. See instructions for sizing gas supply piping.

3. Check piping for leaks. Use an approved gas detector or a non-corrosive leak detection fluid. If leaks are found, turn off all gas supply to the appliance and repair as necessary.

4. The boiler and its individual shut off valve must be disconnected from the gas supply piping system during any pressure testing of that system at test pressures in excess of 1/2 psi (3.5kPa).

The boiler must be isolated from the gas supply piping system by closing its individual manual shut off valve during any pressure testing of the gas supply piping system at test pressures equal to or less than 1/2 psi (3.5 kPa).

CAUTION

Do not subject the boiler gas valve to pressure in excess of 1/2 psi (3.5 kPa). Doing so may damage the valve.

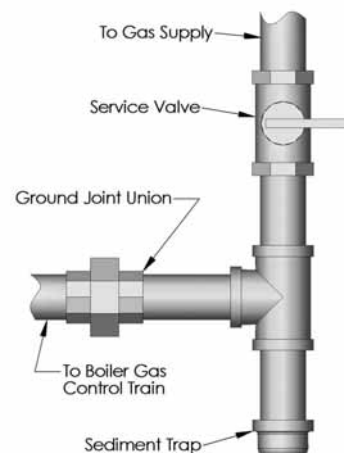

Figure 5.1

- Refer to table 5.4 for minimum supply pressure for the purpose of input adjustment.

Table 5.4: Minimum Supply Pressure Natural Gas

Model	Supply Pressure (in. Water)
63-03L	5.00
63-03	5.00
63-04L	5.00
63-04	5.00
63-05L	5.00
63-05	5.00
63-06	5.00
64-07	5.00
64-08	5.50
64-09	5.00
64-10	5.00
64-11	5.00
64-12	5.00

- Install the boiler such that the gas ignition system components are protected from water (dripping, spraying, rain, etc.) during appliance operation and service (circulator replacement, condensate trap clean out, control replacement, etc.)
- The boiler and its gas connection must be leak tested before placing the boiler in operation.

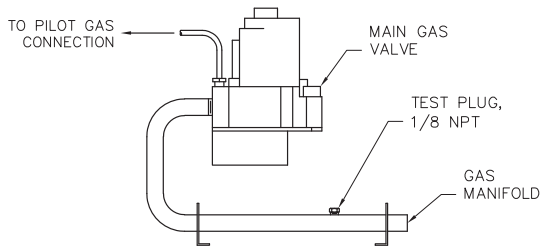

Figure 5.2: Gas Train Manifold 63-03L Through 63-06

- Typical gas train manifolds are illustrated in Figure 5.2 through 5.4.

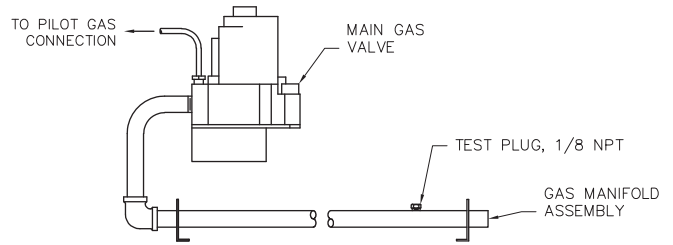

Figure 5.3: Gas Train Manifold - 64-07/08

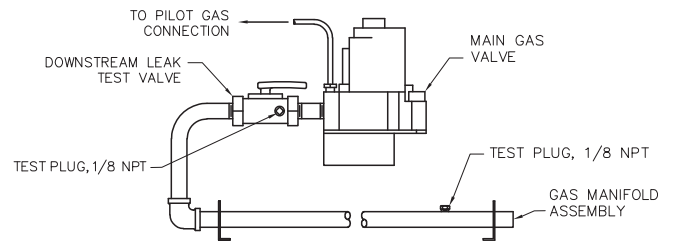

Figure 5.4: Gas Train Manifold - 64-09 Through 64-12

6. CONTROLS & TRIM

A. STEAM BOILER CONTROLS & TRIM

1. Safety Valve:
 - a. Pipe the boiler safety valve provided into the 3/4" tapping on the left side of the boiler as shown in Figure 6.1. Be sure that the relief valve is sized in accordance with local code requirements. In addition, be sure that the safety valve is designed constructed and stamped in accordance with the ASME Boiler and Pressure Vessel Code, Section IV.

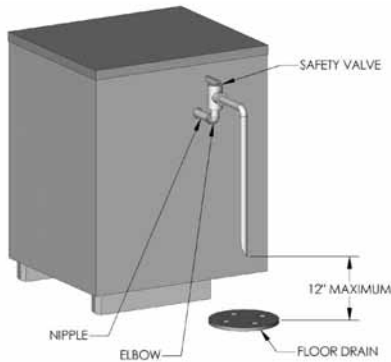

Figure 6.1

- b. If it is necessary to use a boiler relief valve larger than 3/4" due to local codes, the relief valve should be piped in the boiler skim tapping. **Do not increase the pipe size between the boiler and the valve.**
 - c. Pipe the discharge of the safety valve to a maximum of 12" from the floor. Pipe the outlet close to a floor drain.
2. Drain Valve:

Install the 3/4" drain valve provided into the drain tapping on the right hand side of the boiler. Refer to Figure 6.2 for tapping location.

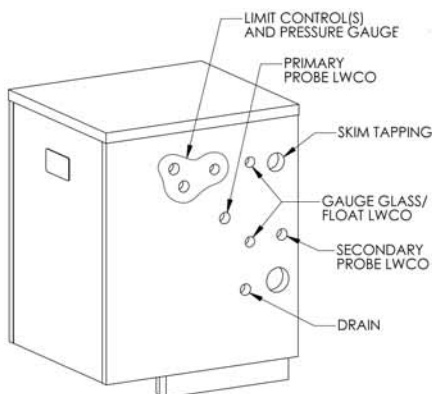

Figure 6.2: Steam Boiler Tapping Location

3. Low Water Cut-off (Level Control):
 - a. **Float Type:** Install the float type low water cut-off (if provided) in conjunction with the gauge glass as shown in Figure 6.3.
 - b. **Probe Type:** Install the optional probe type low water cut-off into the 3/4" tapping on the right side of the boiler. Refer to Figure 6.2 for tapping location. The supplied control incorporates a 60 second off cycle after a 15 minute on cycle. This feature allows the water level in the boiler to settle so that the probe can sense a true water level.

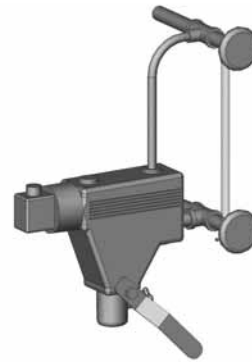

Figure 6.3: Gauge Glass & Low Water Cut-Off Installation

4. Gauge Glass:
 - a. Install the gauge glass provided into two 1/2" tappings on the right side of the boiler. If a float type low water cut-off is used, it will be piped into these same fittings. See Figure 6.3 and 6.4 for examples of this installation.



Figure 6.4: Gauge Glass Installation

5. Pressure Gauge:
 - a. Install the operating limit control and pressure gauge in the 3/4" tappings located on the right side of the boiler. Refer to Figure 6.2 for tapping location.

CONTROLS & TRIM

6. Limit Control(s): (Figure 6.5)
 - a. Install the operating limit control and pressure gauge in the 3/4" tapping located on the right side of the boiler.
 - b. (64-09 through 64-12) Install a high limit control in the 3/4" tapping on the right side of the boiler.

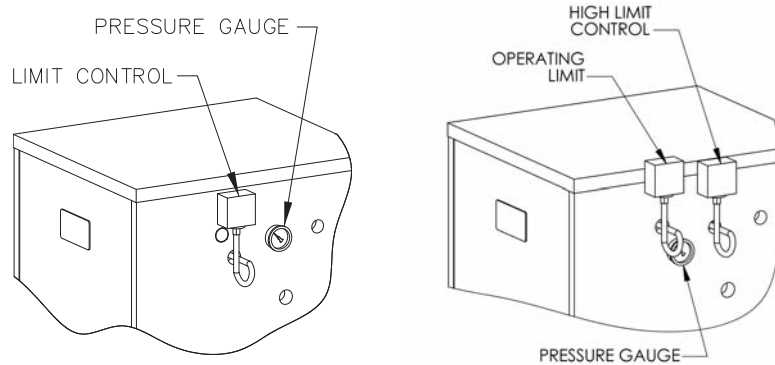

Figure 6.5: Limit Control Installation

⚠ IMPORTANT

In accordance with Section 325 (f) (3) of the Energy Policy and Conservation Act, water boilers are equipped with a feature that saves energy by reducing the boiler water temperature as the heating load decreases. This feature is equipped with an override which is provided primarily to permit the use of an external energy management system that serves the same function.

THIS OVERRIDE MUST NOT BE USED UNLESS AT LEAST ONE OF THE FOLLOWING CONDITIONS IS TRUE:

- An external energy management system is installed that reduces the boiler water temperature as the heating load decreases.
- This boiler is not used for any space heating
- This boiler is part of a modular or multiple boiler system having a total input of 300,000 BTU/hr or greater.
- This boiler is equipped with a tankless coil.

B. WATER BOILER CONTROLS & TRIM

1. Safety Relief Valve:
 - a. Pipe the boiler relief valve into the 3/4" tapping on the left side of the boiler as shown in Figure 6.6. Be sure that the relief valve is sized in accordance with local code requirements. In addition, be sure that the relief valve is designed constructed and stamped in accordance with ASME Boiler and Pressure Vessel Code, Section IV.

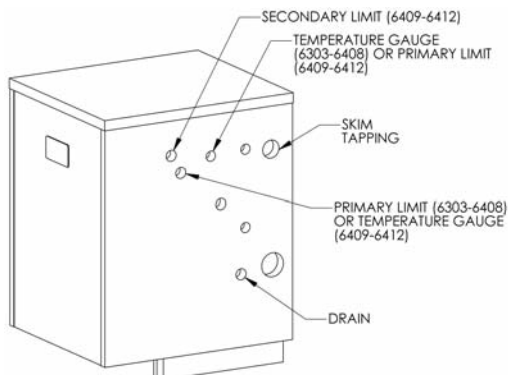

Figure 6.6: Relief Valve Piping Water Boiler

- b. If it is necessary to use a boiler relief valve larger than 3/4" due to local codes, the relief valve should be piped in the boiler skim tapping. **Do not increase the pipe size between the boiler and the valve.**

⚠ CAUTION

Do not install any valves or restrictions between the relief valve and the boiler. Be sure that the inlet to the relief valve is the same or smaller pipe size than the boiler connection.

- c. Pipe the discharge of the safety relief valve to a maximum of 12" from the floor. Pipe the relief outlet close to a floor drain.

⚠ CAUTION

Pipe the discharge of the relief valve away from any traffic area. Failure to do this may cause injury if the valve discharges.

⚠ CAUTION

Pipe the discharge of the relief valve using the full size of the discharge connection.

2. Drain Valve:
Install the 3/4" drain valve provided into the drain tapping on the right hand side of the boiler. Refer to Figure 6.7 for tapping location.
3. Pressure/Temperature Gauge:
Install the pressure/temperature gauge (theraltimeater) supplied with the boiler into the 1/2" tapping located on the right side of the boiler. Refer to Figure 6.7 for tapping location.
4. Limit Control(s):
 - a. Install the operating limit control provided in the 3/4" tapping located on the right side of the boiler. Refer to Figure 6.7 for tapping location.
 - b. (64-09 through 64-12) Install a high limit control in the 3/4" tapping located above the operating limit control. Refer to Figure 6.7 for location.

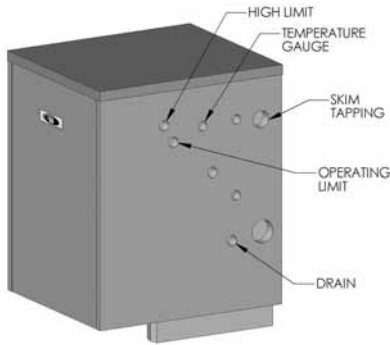

Figure 6.7: Water Boiler Tapping Locations

5. Low Water Cut-off (Level Control)
 - a. A hot water boiler installed above radiator level or as required by the authority having jurisdiction must be provided with a low water cut-off device either as part of the boiler or at the time of installation.
 - b. If a probe-type low water cut-off is used it should be piped into the boiler supply piping as shown in Figure 6.8.

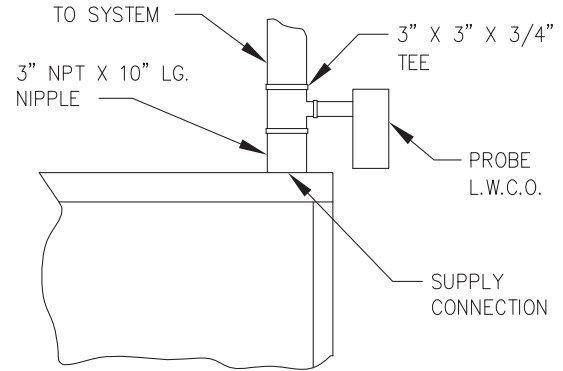

Figure 6.8: Probe Low Water Cut-off Piping

7. ELECTRICAL

A. CONNECT SUPPLY WIRING

1. All electrical wiring must be done in accordance with local codes. In the absence of local codes use ANSI/NFPA 70 "The National Electrical Code."

⚠ CAUTION

Label all wires prior to disconnection when servicing controls. Wiring errors can cause improper and dangerous operation. Verify proper operation after servicing.

⚠ AVERTISSEMENT

Identifier tous les câbles avant de les débrancher au moment d'effectuer l'entretien des commandes. Des erreurs dans le raccordement des câbles d'alimentation peuvent causer un fonctionnement inadéquat et dangereux. Vérifier le bon fonctionnement après les travaux d'entretien.

2. The boiler must be electrically bonded to ground in accordance with the requirements of the authority having jurisdiction or, in the absence of such requirements, with the *National Electrical Code*, ANSI/NFPA 70 and/or the *Canadian Electrical Code* Part 1, CSA C22.1, Electrical Code.
3. The boiler is to be connected to a separate, permanently live electrical supply line with a fused disconnect switch.

B. MOUNT REMAINING CONTROLS

1. Steam Boilers – Mount the control transformer on the junction box as shown in Figure 7.1.

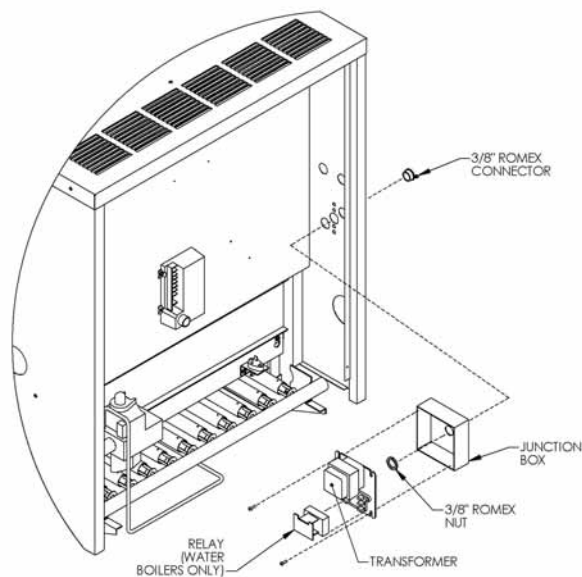

Figure 7.1: Steam Boilers

2. Mount the blocked vent switch in the rear of the boiler on the draft hood as shown in Figure 7.2.

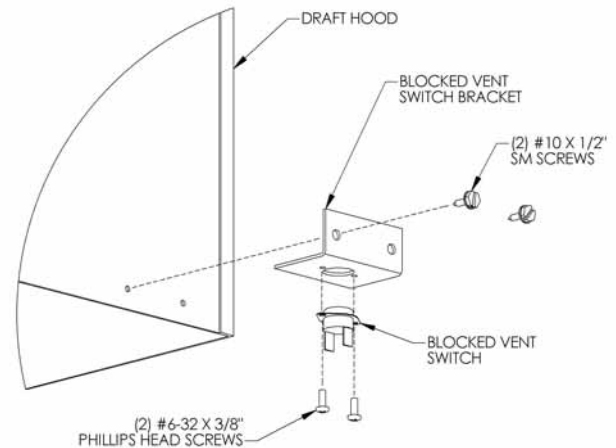

Figure 7.2

3. Mount the flame rollout switch as shown in Figure 7.3.

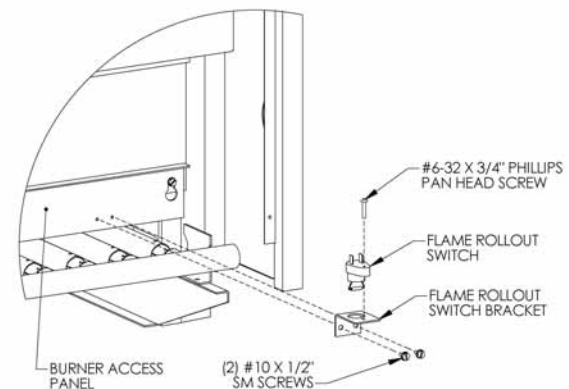

Figure 7.3

4. Mount the ignition module as shown in Figure 7.4.

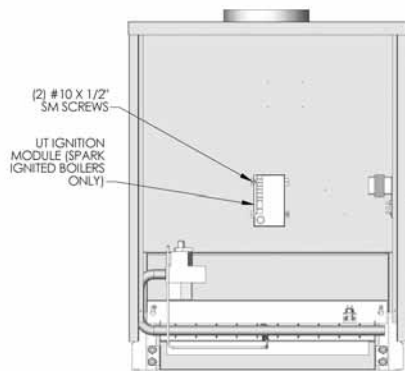
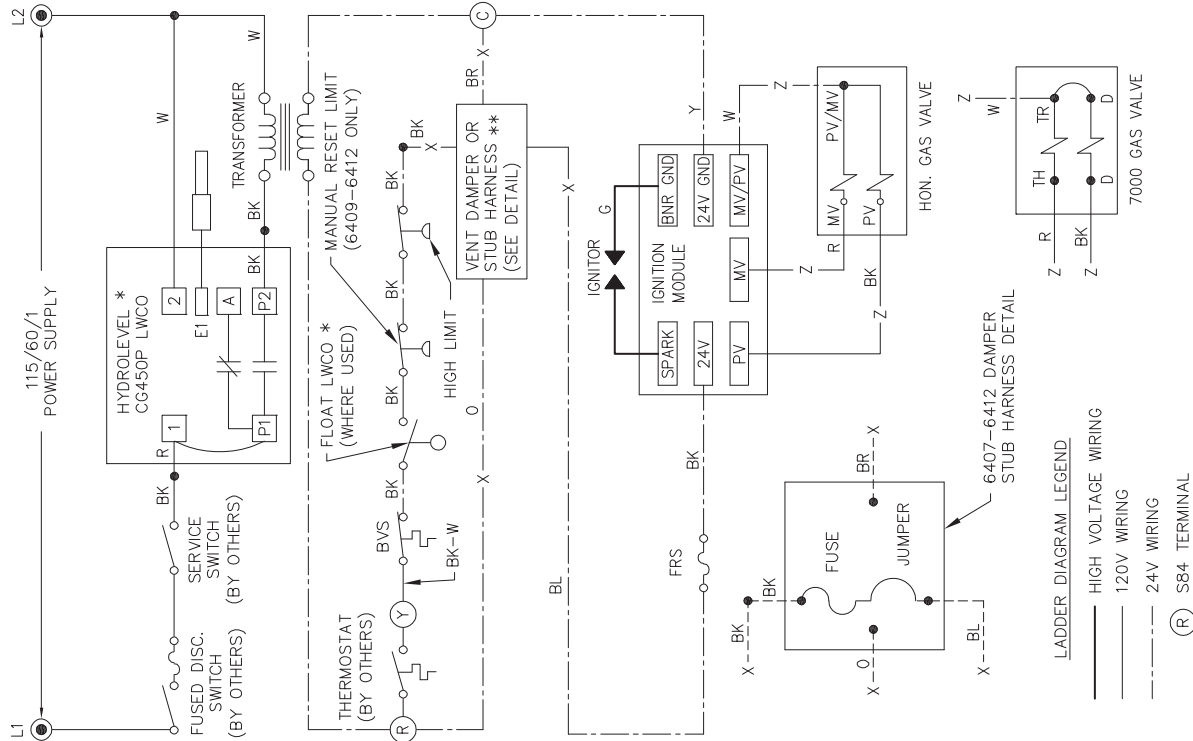

Figure 7.4

C. INSTALL CONTROL WIRING

1. Wire the boiler according to the wiring diagram supplied with the boiler (in the Control Envelope). Figures 7.5 to 7.9 are provided for reference only.
2. Install all line voltage wiring in approved electrical conduit.
3. Do not install single pole switches, including safety controls, in the neutral leg.

LADDER DIAGRAM



CONNECTION DIAGRAM

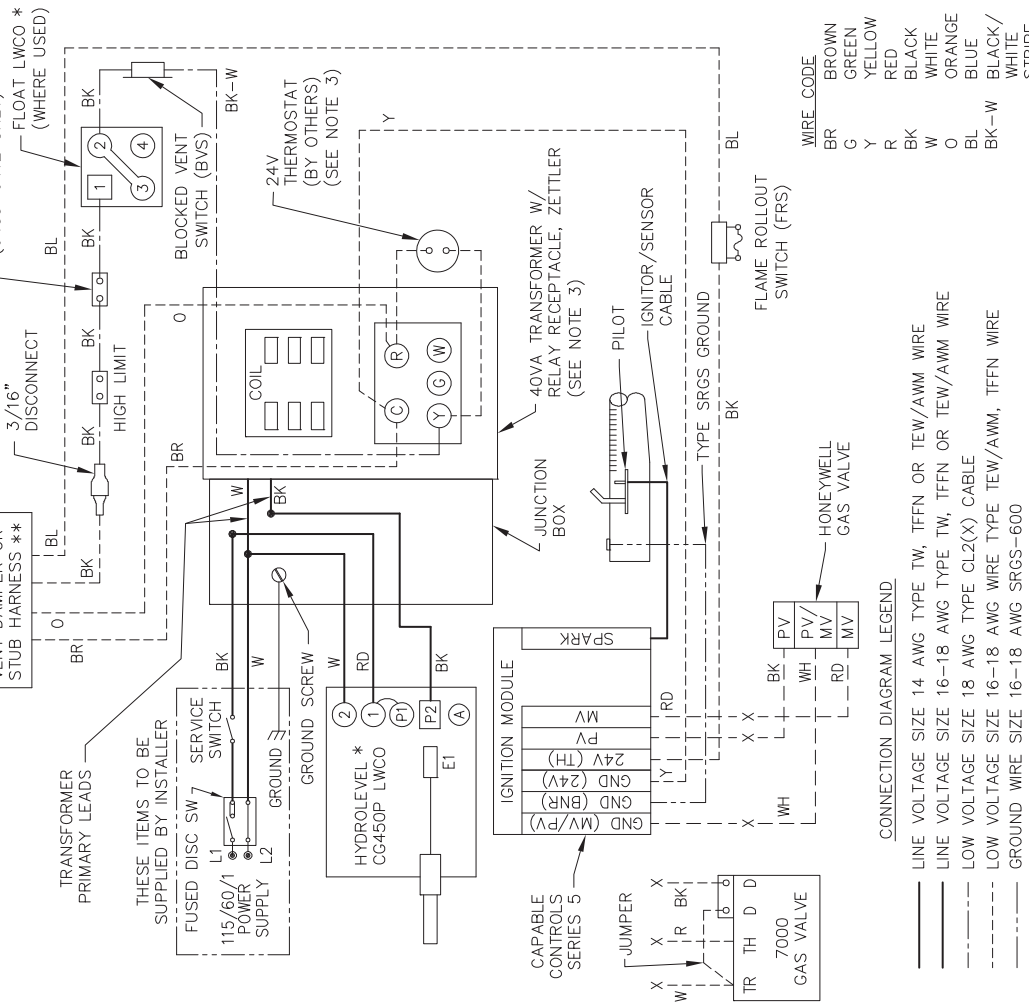

- NOTES:
- 1) ALL WIRING MUST COMPLY WITH APPLIANCE CODES, ORDINANCES AND REGULATIONS.
 - 2) IF ANY OF THE ORIGINAL WIRE AS SUPPLIED WITH THE APPLIANCE MUST BE REPLACED, IT MUST BE REPLACED WITH WIRE AS SHOWN.
 - 3) ZETTLER RECEPTACLE ACCEPTS OPTIONAL W-R 90-340 OR HON. R8222D, N, V (TRADELINE) ISOLATION RELAY. IF ADDING RELAY, DISCONNECT THERMOSTAT LEAD FROM TERMINAL Y AND CONNECT INSTEAD TO TERMINAL G.
- * PROBE IS SECONDARY WHEN USED WITH FLOAT LWCO.
 ** SECONDARY PROBE IS CG550 WHEN MANUAL RESET IS REQUIRED.
 *** 6407-6412 HAVE STUB HARNESS TO CONNECT OPTIONAL VENT DAMPER.

Figure 7.6: Steam Boiler - Wiring Diagram for Models with Probe Low Water Cut-off

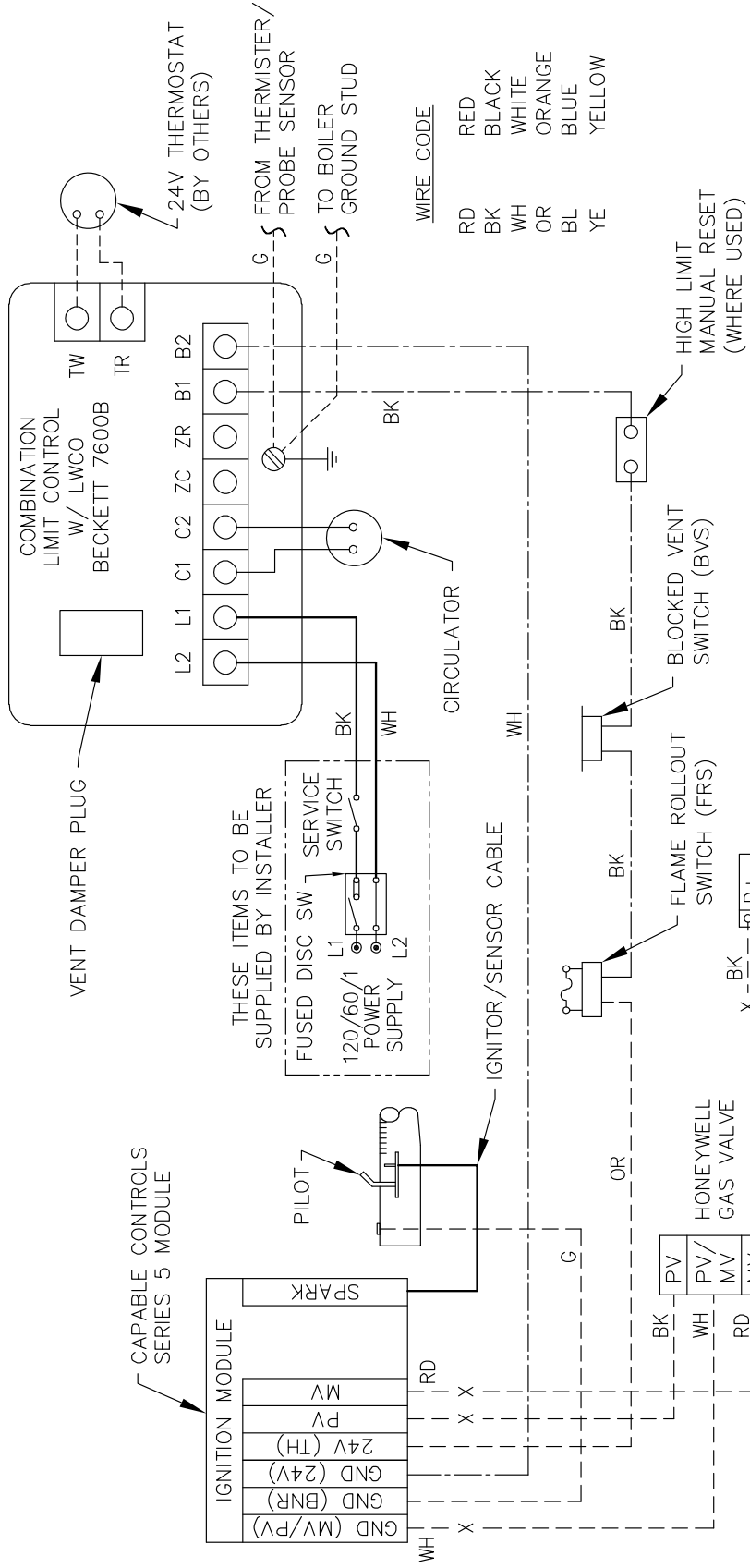

WIRE CODE

NOTES:

- 1) ALL WIRING MUST COMPLY WITH APPLIANCE CODES, ORDINANCES AND REGULATIONS.
- 2) IF ANY OF THE ORIGINAL WIRE AS SUPPLIED WITH THE APPLIANCE MUST BE REPLACED, IT MUST BE REPLACED WITH WIRE AS SHOWN.
- 3) DANS LE CAS OÙ LES CÂBLES ORIGINAUX DE CET APPAREIL DEVRAIENT ÊTRE REMPLACÉS, LES CÂBLES DE REMPLACEMENT DOIVENT ÊTRE TELS QUE CEUX ILLUSTRÉS.

LEGEND

- LINE VOLTAGE SIZE 14 AWG TYPE TW, TFFN OR TEW/AWM WIRE
- - - LOW VOLTAGE SIZE 18 AWG TYPE CL2X WIRE
- - - LOW VOLTAGE SIZE 16-18 AWG WIRE TYPE TEW/AWM, TFFN WIRE

X7106 R1

Figure 7.7: Water Boiler with Beckett AquaSmart™ 7600B Limit Control

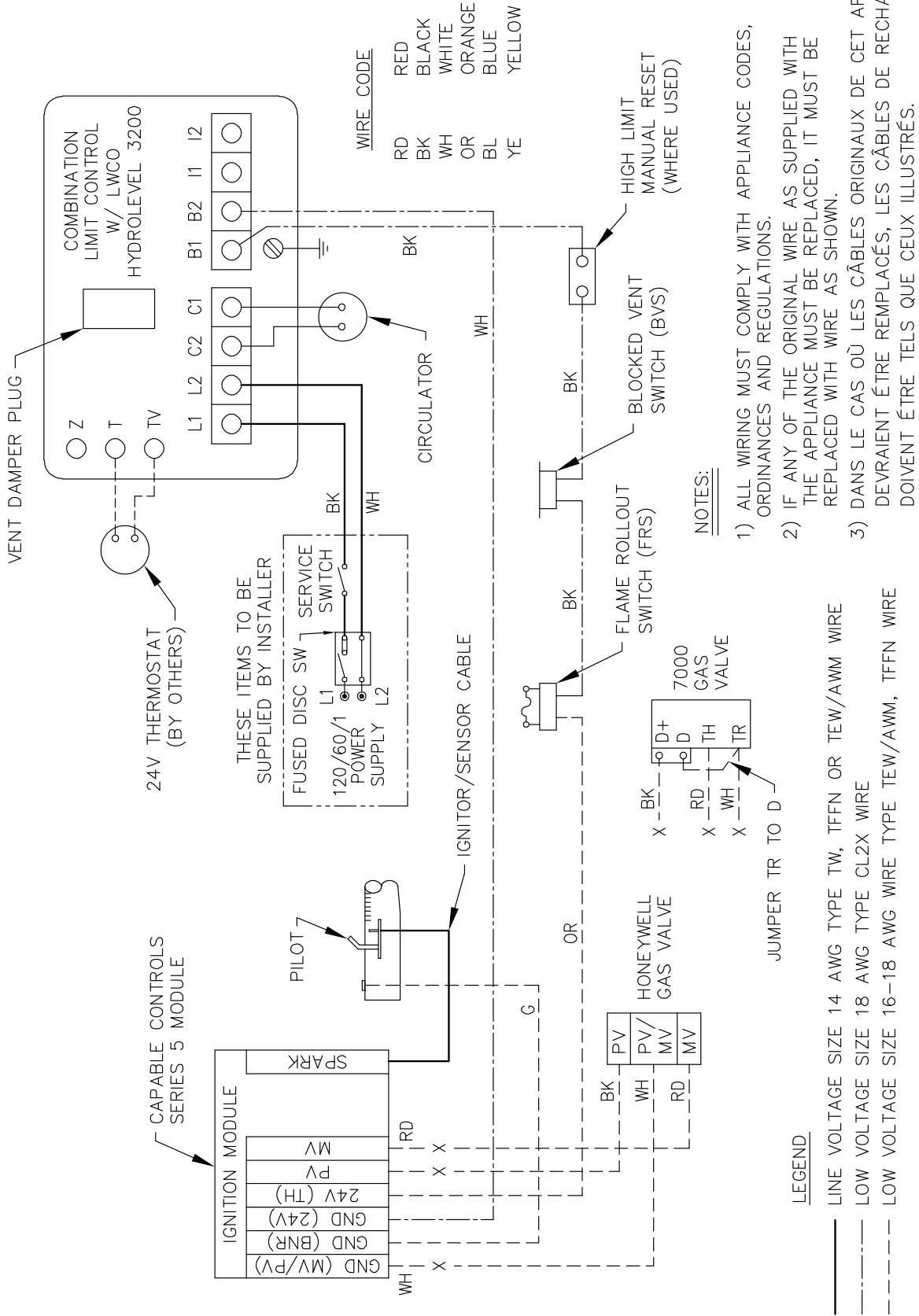

X7108 R1

Figure 7.8: Water Boiler with Hydrolevel Hydrostat® 3200 Limit Control

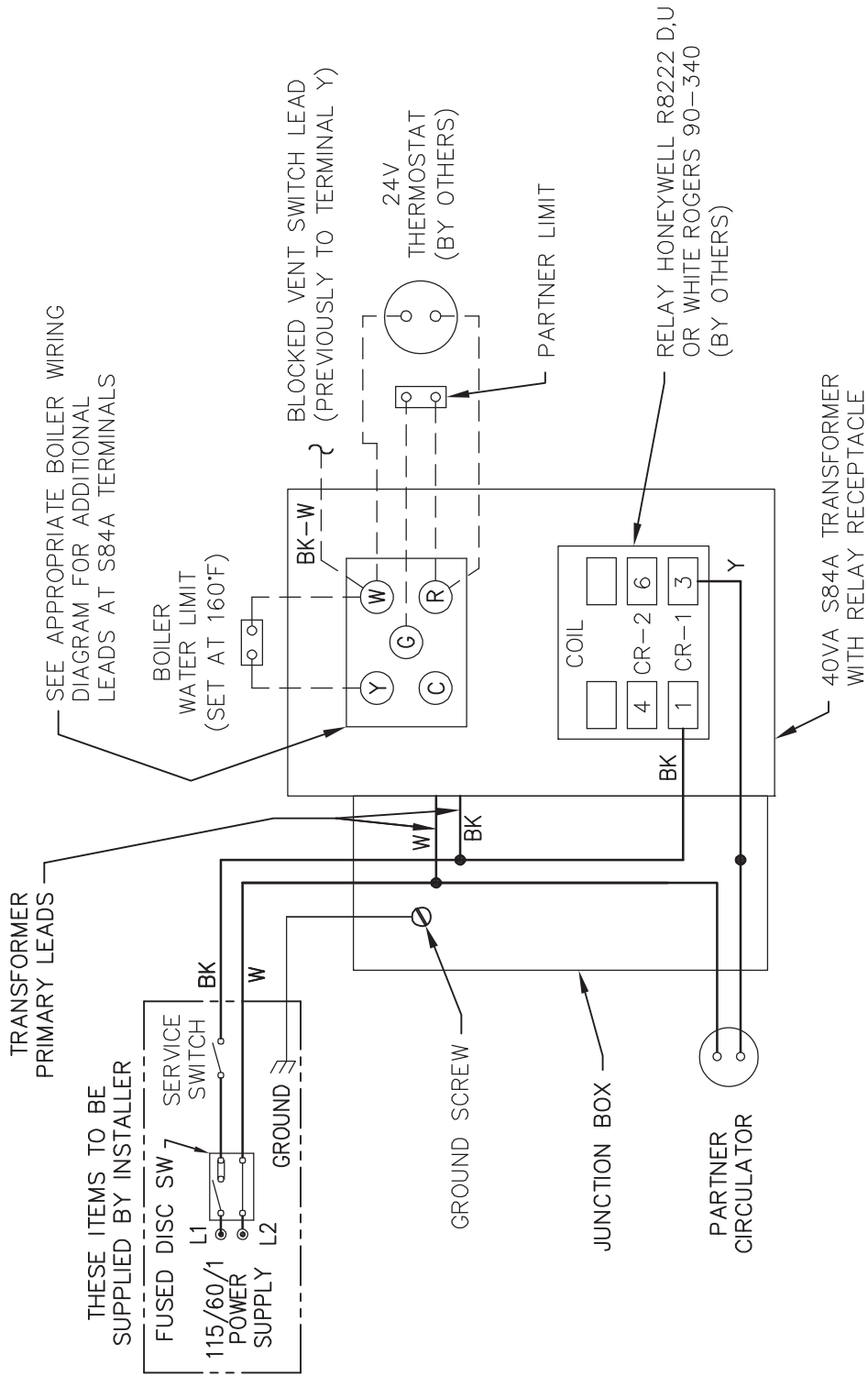

Figure 7.9: Typical Steam Boiler Indirect Water Heater Wiring

8. BOILER OPERATION

A. SYSTEM INSPECTION

1. Confirm that all water, gas, and electricity are turned off.
2. Inspect the boiler combustion chamber for obstructions. Clear any debris from the combustion chamber.
3. Check the condition of the burners and pilot assembly. Make certain that there are no unusual bends. Replace components if necessary.
4. Verify that water piping, gas piping and electrical wiring are installed properly. Be sure that all components are installed correctly. Refer to these instructions as well as to component manufacturer's instructions.

B1. FILL THE BOILER (WATER BOILERS)

1. Fill the boiler and system with water making certain to vent air from all high points in the system. Water should bleed from each air vent when it is opened.
2. The pressure reducing valve on the fill line will typically allow the system to be filled and pressurized to 12 psi. Consult the valve and expansion tank manufacturer for more detailed information.
3. Check all joints and fittings throughout the system for leaks. If leaks are found, drain the system and repair as required.
4. If the water hardness is high, use water treatment to reduce the deposition of minerals in the boiler.
5. If the system requires antifreeze protection, use only propylene glycol specially formulated for hydronic systems. These contain inhibitors that prevent corrosion of the boiler and system components. Do not use ethylene glycol or automotive antifreezes.
 - a. Make sure that the antifreeze supplier can provide periodic testing of antifreeze concentration and inhibitor level.
 - b. If an automatic fill valve is used, the solution strength in the system must be checked to assure that the antifreeze concentration has not been overly diluted.
 - c. Local codes may require the addition of a backflow preventer or manual fill only with separation from the city water supply.
 - d. Consider the minimum temperature of potential exposure in the system when deciding on the antifreeze concentration. A concentration of 50% generally provides protection from freezing to -30°F.

B2. FILL THE BOILER (STEAM BOILERS)

1. Gravity Systems and Pumped Return with Condensate Units – Fill the boiler to the normal water line as indicated on the boiler jacket. The normal water level is about 25-7/8" above the boiler foundation (about 2/3 of the gauge glass).
2. Pumped Return Systems with Boiler Feed Unit - Fill the boiler using the boiler feed unit. The fill level will depend on the control being used but should be roughly 25-7/8" above the boiler foundation (about 2/3 of the gauge glass) when the feed pump stops.
3. Check all joints and fittings in system piping below the water line for leaks and repair as necessary.

C. STUDY OPERATING INSTRUCTIONS

Before starting the boiler, study the Operating Instructions supplied with the boiler. Figure 8.2 to 8.4 show typical Lighting Instructions for typical boilers.

D. RUN PILOT CHECK-OUT

1. Shut off all electrical power to the boiler.
2. Close Main and Pilot gas shut-off valves. Wait for five (5) minutes.
3. Set the Operating and Limit Temperature Controls to minimum setting so they will not call for heat.
4. Perform Pilot Check:
 - a. Turn main electric disconnect switch to the "ON" position.
 - b. Turn up the settings on the Operating and Limit Temperature Controls so they will call for heat.
 - c. Check for a continuous spark at the electronic spark-ignited pilot.
 - d. The control will spark for 90 seconds (trial for ignition), then shut down for a 5 to 6 minute wait period before attempting another ignition.
 - e. Turn down the Operating Temperature Control to stop the call for heat.
 - f. Wait 60 seconds to allow the control to reset before proceeding with the next step.
5. Spark-Ignited Pilot Ignition Check
 - a. Turn up the Operating Temperature Control for a call for heat.
 - b. The spark-ignited pilot should ignite.
 - c. Turn down the Operating Temperature Control to stop the call for heat.
 - d. The spark-ignited pilot should shut off.

BOILER OPERATION

6. Check Main Burner Ignition
 - a. With the Operating Temperature Control turned down, open the main gas shut-off valve(s).
 - b. Turn up the Operating Temperature Control for a call for heat.
 - c. The electronic spark-ignited pilot(s) should ignite.
 - d. The main gas valves will then open and the main burners should ignite.
 - e. Turn down the Operating Temperature Control to stop the call for heat.
 - f. The electronic spark-ignited pilot(s) and main burners should shut off.

E. CHECK MAIN BURNER SYSTEM

1. Remove the pressure test plug at the Main gas shut-off valve. Attach a U-tube manometer.
2. Restart the boiler by turning up the Operating Temperature Control for a call for heat.
3. Leak test all gas train joints with a soap suds solution.
4. Check the gas pressure at the entrance to the Gas Control train.
 - a. The pressure reading under flow should be between 5.5 and 13.5 inches water column
 - b. If the pressure to the Gas Control Train exceeds 13.5 inches under any conditions, the system must be provided with a lockup type gas pressure regulator to provide 13.5 inches maximum.
5. Check the Manifold gas pressure.
 - a. Remove the 1/8" pipe plug from the manifold gas pressure tapping.
 - b. Attach a U-tube manometer.
 - c. Adjust the Main Gas Pressure Regulator to obtain 3.5 inches water column on Natural Gas or 10 inches water column on Propane (LP) Gas.
 - d. NOTE: If the pressure is adjusted to set the nameplate input to the boiler, do not set it more than 0.3 inches plus or minus from the specified settings. If more adjustment to the rate is needed, it must be done by changing the burner gas orifices.
6. Check the burner input by reading the gas meter.
 - a. The required input rate is listed for each model in Section II, Dimensions & Ratings.
 - b. Determine the input by multiplying "F" – Meter Reading (Cubic Feet of Gas) times "H" – Heating Value of Gas (Btu per Cubic Foot) times 3600. Divide by "T" – the time in seconds at the meter reading.
$$\text{Rate, Btu/Hr} = \frac{F \times H \times 3600}{T}$$
 - c. Note: If the meter is not automatically corrected for temperature and pressure, the meter reading must be corrected to actual conditions during the rate test.

7. Check the burner and pilot flames (see Figure 8.1). The flame inner cone should be about 1-1/2" high and should have a very sharp blue color. Poor flame conditions can be caused by dirty burners, obstructed orifices or incorrect gas pressure.

F. CHECK BOILER CONTROLS

1. Limit and Operating Controls:
 - Lower the set point of each control until the burners shut down. Note that the system pressure (or temperature) corresponds to the limit setting.
 - Return the controls to the desired set point.
2. Low Water Cut-off (if used):
 - Consult the manufacturer's instructions for the low water cut-off operational check procedure.
3. Main Gas Safety Shut-off Valve:
 - Close main supply manual shut-off valve. The main gas safety shut-off valve should de-energize.
 - Open the manual supply valve. Re-light the boiler in accordance with the lighting instructions.

G. PURGE AIR FROM THE SYSTEM (WATER BOILERS ONLY)

1. Purge the system using purge valves, isolating zones in the process or use system vents. Do not operate the pump(s) while purging. Pumps will hold air in the eye of the impeller.
2. Allow the system to reach 180°F and use manual vents, if installed, to remove any remaining air.

H. CHECK THE SYSTEM PRESSURE (WATER BOILERS ONLY)

Watch the pressure gauge as the system approaches 180°F. If the pressure exceeds the design operating pressure, check:

- a. Fill valve pressure.
- b. Expansion or compression tank operation and sizing.

I. CLEAN THE BOILER (STEAM BOILERS ONLY)

1. Clean the boiler as described below no later than one week after the initial start-up. Cleaning will be more effective if the boiler operates 24 to 48 hours in order to loosen sediment and impurities in the system.
2. The boiler must be cleaned to remove any accumulation of oil, grease, sludge, or other impurities that may be in the system. These substances can cause foaming and surging of the boiler water, producing an unstable water line and water carryover to the system.

⚠ WARNING

Cleaning the boiler requires the use of very hot water and corrosive chemicals. Use care when handling to prevent injury.

3. Thread a 1-1/4" NPT Pipe Nipple into the "Skim Tapping" (Connection "J" in Figure 11.1). Tighten firmly.
4. Thread a 1-1/4" NPT ball valve onto the nipple and connect a 1-1/4" drain line.
5. Close all valves to the system. Provide a means of supplying fresh water to the boiler.

⚠ CAUTION

Do not leave the boiler unattended while performing boil out. Do not allow the water to drop below the bottom of the gauge glass or allow make up water to enter too quickly. This will avoid the possibility of causing failure of the boiler sections.

6. Use common washing soda (such as Arm & Hammer Super Washing Soda). For each 800 square feet EDR net boiler rating, mix one pound of washing soda with water. Pour mixture into safety relief valve tapping.
7. Open the skim valve. Fill the boiler until water begins to flow out of the valve.
8. Turn burners on and allow the boiler water to heat up to between 180°F and 200°F. Cycle the burners to maintain temperature during skimming. Do not allow the boiler to steam. Steaming mixes up the contaminants in the water instead of floating them at the surface.
9. Open the make-up water valve to continuously feed water to the boiler. Allow water to flow out of the skim tapping.
10. Continue skimming the boiler until the water flowing from the skim tapping flows clear. This will likely take several hours for a dirty system.
11. After skimming is complete, close the skim valve and turn off the boiler.

12. Close the make up water valve and open the boiler drain valve.
13. Drain the boiler completely. Then refill and drain again one or two times to make sure all of the soda has been washed out.
14. Open the valves to the system and replace the skim valve with a pipe cap.

⚠ NOTICE

If the gauge glass becomes dirty again, this indicates that more contaminants have worked loose in the system. Repeat the cleaning and skimming process as needed to clean the system.

J. TO SHUT DOWN THE BOILER

1. Open main line power disconnect switch to boiler.
2. Close Main and Pilot gas shut-off valves.
3. To take boiler out of service if the boiler and system are not to be used when temperatures are below freezing:
 - a. Drain the boiler and system completely and shut off make-up water supply.
 - b. Open main line power disconnect switch to boiler. Remove the fuses or secure the switch so that the power cannot be turned on accidentally.
 - c. Be certain that the boiler and system are refilled before returning to service. Follow the Instructions in this manual and the Lighting Instructions to operate.

⚠ CAUTION

Before servicing the boiler:

- **Turn off all electrical power to the boiler.**
- **Close the Gas Service Valve.**
- **Allow the boiler to cool if it has been operating.**
- **Label all wires prior to disconnection when servicing controls. Wiring errors can cause improper and dangerous operation. Verify proper operation after servicing.**

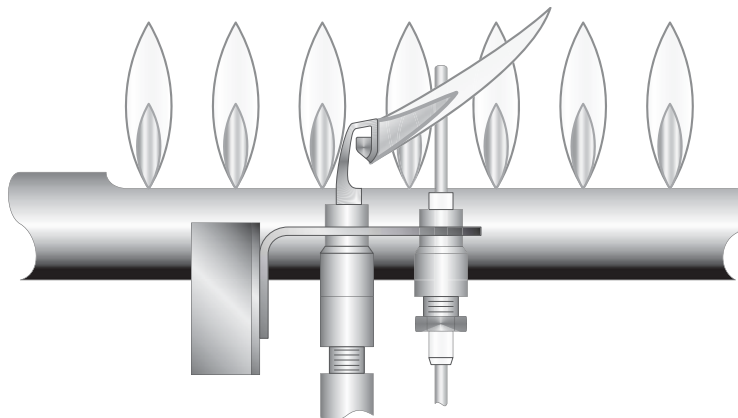

Figure 8.1: Pilot and Burner Flames

FOR YOUR SAFETY READ BEFORE LIGHTING

WARNING: If you do not follow these instructions exactly, a fire or explosion may result causing property damage, personal injury, or loss of life.

- A. This appliance is equipped with an ignition device which automatically lights the pilot. Do not try to light the pilot by hand.
 - B. BEFORE OPERATING smell all around the appliance area for gas. Be sure to smell next to the floor because some gas is heavier than air and will settle on the floor.
 - C. Use only your hand to push in or turn the gas control knob. Never use tools. If the knob will not push in or turn by hand, don't try to repair it, call a qualified service technician. Force or attempted repair may result in a fire or explosion.
 - D. Do not use this appliance if any part has been under water. Immediately call a qualified service technician to inspect the appliance and to replace any part of the control system and any gas control which has been under water.
- WHAT TO DO IF YOU SMELL GAS**
- Do not try to light any appliance
 - Do not touch any electric switch; do not use any phone in your building.
 - Immediately call your gas supplier from a neighbor's phone. Follow the gas supplier's instructions.
 - If you cannot reach your gas supplier, call the fire department.

OPERATING INSTRUCTIONS

1. STOP! Read the safety information above on this label.
2. Set the thermostat or operating control to lowest setting.
3. Turn off all electric power to the appliance.
4. This appliance is equipped with an ignition device which automatically lights the pilot. Do not try to light the pilot by hand.
5. If the gas valve is not visible, remove control access panel.
6. If the gas control knob is not in the "OFF" position, turn the knob clockwise ↻ to "OFF".
7. Wait five (5) minutes to clear out any gas. Then smell for gas, including near the floor. If you smell gas, STOP! Follow "B" in the safety information above on this label. If you don't smell gas, go to the next step.
8. Turn the gas control knob counterclockwise ↺ to "ON".
9. Replace control access panel, if applicable.
10. Turn on all electrical power to the appliance.
11. Set thermostat or operating control to desired setting.
12. If the appliance will not operate, follow the instructions "To Turn Off Gas To Appliance" and call your service technician or gas supplier.

Gas Control Knob (shown in "OFF" position)

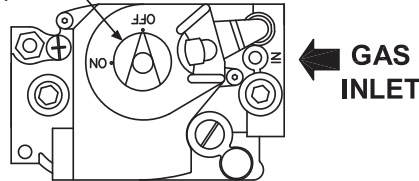

TO TURN OFF GAS TO APPLIANCE

1. Set the thermostat or operating control to lowest setting.
2. Turn off all electric power to the appliance if service is to be performed.
3. If the gas valve is not visible, remove the control access panel.
4. Turn the gas control knob clockwise ↻ to "OFF".
5. Replace control access panel, if applicable.

HSP VR8204/VR8304 9181R REV.2

Figure 8.2: 63-03 thru 64-08 Nat/LP, 64-09 thru 64-12 LP Gas

POUR VOTRE SÉCURITÉ, LISEZ AVANT L'ALLUMAGE

MISE EN GARDE: Négliger de suivre ces instructions à la lettre pourrait provoquer un incendie ou une explosion causant des dégâts matériels, des blessures ou la mort.

- A. Cet appareil est muni d'un dispositif d'allumage automatique de la veilleuse. Ne tentez pas d'allumer la veilleuse à la main.
- B. **AVANT DE METTRE EN MARCHÉ**, sentez autour de l'appareil pour détecter toute odeur de gaz. Etant donné que certains gaz sont plus lourds que l'air et se déposent sur le sol, s'assurer de bien sentir près du plancher.
- QUE FAIRE SI VOUS DÉTECTEZ UNE ODEUR DE GAZ**
- Ne pas tenter d'allumer l'appareil
 - Ne toucher à aucun interrupteur électrique; n'utiliser aucun appareil téléphonique dans l'immeuble.
 - Contactez immédiatement votre fournisseur de gaz à partir du téléphone d'un voisin. Suivre les instructions données par votre fournisseur de gaz.
- S'il est impossible de rejoindre le fournisseur de gaz, appeler le service des incendies.
- C. N'utilisez que votre main pour appuyer ou tourner le bouton de commande du gaz. Ne jamais utiliser d'outils. S'il est impossible d'enfoncer ou de tourner le bouton à la main, ne tentez pas de le réparer. Appelez un technicien d'entretien qualifié. Une force excessive ou une tentative de réparation peut provoquer un incendie ou une explosion.
- D. N'utilisez pas cet appareil ni aucune de ses pièces si elles ont été immergées. Contactez immédiatement un technicien d'entretien qualifié pour inspecter l'appareil et remplacer toute pièce du système de régulation du débit gazeux et toute commande de gaz ayant été immergée.

DIRECTIVES DE FONCTIONNEMENT

1. **ARRÊTEZ!** Lisez les consignes de sécurité plus haut sur cette étiquette.
2. Réglez le thermostat ou l'appareil de réglage au niveau le plus bas.
3. Coupez toute l'alimentation électrique de l'appareil.
4. Cet appareil est muni d'un dispositif d'allumage automatique de veilleuse. Ne tentez pas d'allumer la veilleuse à la main.
5. Si la soupape d'alimentation en gaz n'est pas visible, retirez le panneau d'accès.
6. Si le bouton de commande du gaz n'est pas en position « OFF », tournez le bouton dans le sens des aiguilles d'une montre pour les mettre à « OFF ».
7. Attendre cinq (5) minutes pour que tout le gaz présent puisse s'échapper. Sentir autour de l'appareil pour détecter toute odeur de gaz, incluant près du sol. Si vous sentez une odeur de gaz, **ARRÊTEZ!** Suivez les consignes de sécurité apparaissant en « B » plus haut sur cette étiquette. Si vous ne détectez aucune odeur de gaz, passez à l'étape suivante.
8. Tournez le bouton de commande dans le sens contraire des aiguilles d'une montre pour le mettre en position de marche « ON ».
9. Remplacez le panneau d'accès du régulateur de débit, le cas échéant.
10. Remettez en marche toute l'alimentation électrique de l'appareil.
11. Réglez le thermostat ou l'appareil de réglage au niveau désiré.
12. Si l'appareil ne se met pas en marche, suivez les instructions ci-dessous : « Couper l'alimentation en gaz de l'appareil » et appelez votre technicien d'entretien ou fournisseur de gaz.

Bouton de contrôle du débit (illustré en position d'arrêt « OFF »)

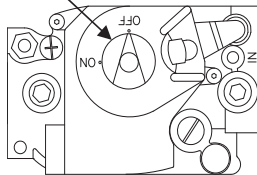

← ARRIVÉE DE GAZ

COUPER L'ALIMENTATION EN GAZ DE L'APPAREIL

1. Réglez le thermostat ou l'appareil de réglage au niveau le plus bas.
2. Si des travaux d'entretien doivent être effectués, couper toute l'alimentation électrique de l'appareil.
3. Si la soupape d'alimentation en gaz n'est pas visible, retirez le panneau d'accès.
4. Tournez le bouton de commande dans le sens des aiguilles d'une montre pour les mettre en position d'arrêt « OFF ».
5. Remplacez le panneau d'accès du régulateur de débit, le cas échéant.

HSP VR8204/VR8304 9414 REV 0 (MM/AA)

Figure 8.3: 63-03 thru 64-08 Nat/LP, 64-09 thru 64-12 LP Gas

FOR YOUR SAFETY READ BEFORE LIGHTING

WARNING: If you do not follow these instructions exactly, a fire or explosion may result causing property damage, personal injury, or loss of life.

- A. This appliance is equipped with an ignition device which automatically lights the pilot. Do not try to light the pilot by hand.
 - B. BEFORE OPERATING smell all around the appliance area for gas. Be sure to smell next to the floor because some gas is heavier than air and will settle on the floor.
 - C. Use only your hand to push in or turn the gas control knob. Never use tools. If the knob will not push in or turn by hand, don't try to repair it, call a qualified service technician. Force or attempted repair may result in a fire or explosion.
 - D. Do not use this appliance if any part has been under water. Immediately call a qualified service technician to inspect the appliance and to replace any part of the control system and any gas control which has been under water.
- WHAT TO DO IF YOU SMELL GAS**
- Do not try to light any appliance
 - Do not touch any electric switch; do not use any phone in your building.
 - Immediately call your gas supplier from a neighbor's phone. Follow the gas supplier's instructions.
 - If you cannot reach your gas supplier, call the fire department.

OPERATING INSTRUCTIONS

1. STOP! Read the safety information above on this label.
2. Set the thermostat or operating control to lowest setting.
3. Turn off all electric power to the appliance.
4. This appliance is equipped with an ignition device which automatically lights the pilot. Do not try to light the pilot by hand.
5. If the gas valve is not visible, remove control access panel.
6. If the gas control knob is not in the "OFF" position, turn the knob clockwise ↻ to "OFF".
7. Wait five (5) minutes to clear out any gas. Then smell for gas, including near the floor. If you smell gas, STOP! Follow "B" in the safety information above on this label. If you don't smell gas, go to the next step.
8. Turn the gas control knob counterclockwise ↺ to "ON".
9. Replace control access panel, if applicable.
10. Turn on all electrical power to the appliance.
11. Set thermostat or operating control to desired setting.
12. If the appliance will not operate, follow the instructions "To Turn Off Gas To Appliance" and call your service technician or gas supplier.

Gas Control Knob
(shown in "OFF"
position)

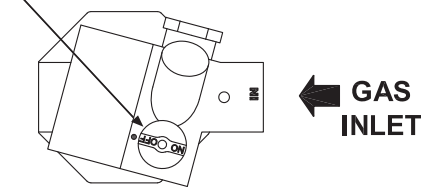

TO TURN OFF GAS TO APPLIANCE

1. Set the thermostat or operating control to lowest setting.
2. Turn off all electric power to the appliance if service is to be performed.
3. If the gas valve is not visible, remove the control access panel.
4. Turn the gas control knob clockwise ↻ to "OFF".
5. Replace control access panel, if applicable.

SPRK 7000DERHC 9363R REV.0

Figure 8.4: 64-09 thru 64-12 Nat Gas

9. MAINTENANCE

WARNING

Product Safety Information Refractory Ceramic Fiber Product

This appliance contains materials made from refractory ceramic fibers (RCF). Airborne RCF fibers, when inhaled, have been classified by the International Agency for Research on Cancer (IARC), as a possible carcinogen to humans. After the RCF materials have been exposed to temperatures above 1800°F, they can change into crystalline silica, which has been classified by the IARC as carcinogenic to humans. If particles become airborne during service or repair, inhalation of these particles may be hazardous to your health.

Avoid Breathing Fiber Particulates and Dust

Suppliers of RCF recommend the following precautions be taken when handling these materials:

Precautionary Measures:

Provide adequate ventilation.

Wear a NIOSH/MSHA approved respirator.

Wear long sleeved, loose fitting clothing and gloves to prevent skin contact.

Wear eye goggles.

Minimize airborne dust prior to handling and removal by water misting the material and avoiding unnecessary disturbance of materials.

Wash work clothes separately from others. Rinse washer thoroughly after use.

Discard RCF materials by sealing in an airtight plastic bag.

First Aid Procedures:

Inhalation: If breathing difficulty or irritation occurs, move to a location with fresh clean air. Seek immediate medical attention if symptoms persist.

Skin Contact: Wash affected area gently with a mild soap and warm water. Seek immediate medical attention if irritation persists.

Eye Contact: Flush eyes with water for 15 minutes while holding eyelids apart. Do not rub eyes. Seek immediate medical attention if irritation persists.

Ingestion: Drink 1 to 2 glasses of water. Do not induce vomiting. Seek immediate medical attention.

A. GENERAL

1. Disconnect this boiler from the gas supply piping during any pressure testing of the gas system.
2. Check pipes adjacent to cold walls or in unheated spaces. Insulate and tape them if necessary to be sure they can't freeze up. Keeping the water moving at all times will reduce the likelihood of freezing.
3. If there is considerable foreign matter in the boiler water, the boiler should be shut down and allowed to cool, then drained and thoroughly flushed out. Use the drain valve at the bottom of the right side to drain the boiler. Pipe the drain cock to a suitable drain or containment device (if antifreeze is used). Flush the system to remove remaining matter. If there is evidence that hard scale has formed on the internal surfaces, the boiler should be cleaned by chemical means as prescribed by a qualified water treatment specialist.
4. There must be no signs of continuous wetness at the chimney. If signs of continuous wetness are observed, a qualified service agency must be consulted to modify the vent configuration to prevent the formation of condensate, which may damage the vent pipe.

B. DAILY MAINTENANCE (WITH BOILER OPERATING)

Daily boiler observation can be performed by the owner. If any potential problems are found, a qualified installer or service technician/agency must be notified.

1. Remove any combustible materials, gasoline and other flammable liquids and substances that generate flammable vapors from the area where the boiler is contained. Make certain that the boiler area has ample air for combustion and ventilation and that there are no obstructions to the free flow of air to and from the boiler.
2. Observe general boiler conditions (unusual noises, vibrations, etc.)
3. Observe operating temperature and/or pressure on the gauge located on the right side of the boiler. Boiler pressure should never be higher than 5 psi below the rating shown on the safety relief valve. The valve rating can be found on the top of the safety relief valve (see Figure 6.1 or 6.6 for location of the safety relief valve). Boiler temperature should never be higher than 250°F.
4. Check for water leaks in boiler and system piping.
5. Smell around the appliance area for gas. If you smell gas, follow the "To Turn Off Gas to Appliance" procedure listed in the Lighting/Operating Instructions in Section 8.

C. WEEKLY MAINTENANCE (WITH BOILER OPERATING)

1. Flush float-type low-water cut-off (if used) to remove sediment from the float bowl as stated in the manufacturer's instructions.

D. MONTHLY MAINTENANCE (WITH BOILER OPERATING)

1. Check boiler room floor drains for proper functioning.
2. Check function of the safety relief valve (monthly unless specified otherwise by manufacturer) by performing the following test:
 - a. Check valve piping to determine that it is properly installed and supported.
 - b. Check boiler operating temperature and pressure.
 - c. Lift the try lever on the safety relief valve to the full open position and hold it for at least five seconds or until clean water is discharged.
 - d. Release the try lever and allow the valve to close. If the valve leaks, operate the lever two or three times to clear the valve seat of foreign matter. It may take some time to determine if the valve has shut completely.
 - e. If the valve continues to leak, it must be replaced before the boiler is returned to operation.
 - f. Check that operating pressure and temperature have returned to normal.
 - g. Check again to confirm that valve has closed completely and is not leaking.
3. Test low-water cut-off (if used) as described by the manufacturer.
4. Test limit by lowering the limit set point until the main burners shut down. When proper operation is confirmed, return the set point to the desired setting.
5. Test function of gas safety shut-off features as described by gas valve and ignition control manufacturer.
6. Cycle the boiler at least once and check operation of the vent damper.

E. ANNUAL MAINTENANCE (BEFORE START OF HEATING SEASON)

DANGER

When servicing or replacing components, be absolutely certain that the following conditions are met:

- Water, gas and electricity are off.
- The boiler is at room temperature.
- There is no pressure in the boiler.

1. Check flueways and burners for cleanliness and clean if necessary. Use the following procedure if cleaning is required:
 - a. Refer to the Operating Instructions in Section 8 "To Turn Off Gas to Appliance."
 - b. Turn off all electrical power to the boiler.
 - c. Remove burners and brush gas outlet ports lightly using a soft bristle brush.

- d. Remove the vent pipe, vent damper, top jacket panels and flue collector.
- e. Brush flueways with wire brush.
- f. To the extent possible, inspect inside of vent pipe and vent damper for obstructions in flow or vent damper movement. Remove or replace as necessary.
- g. When replacing the flue collector, be certain that the blanket seal between the flue collector and top section makes a tight seal to prevent leakage of the products of combustion.
- h. Re-install the top of the jacket, vent damper and vent pipe.
- i. Connect blocked vent switch wiring harness to blocked vent switch.
- k. Re-install burners.

- 2. Inspect entire venting system for corrosion, support and joint integrity. Repair as necessary.
- 3. Check the pilot and main burner flame. See Figure 8.1. The pilot should provide a steady flame enveloping 3/8" to 1/2" of the flame sensor. If required, adjust the pilot as stated in the gas valve manufacturer's instructions. The main burner flame inner cone should be approximately 1-1/2" high and should have a very sharp, blue color characteristic.

F. AS REQUIRED MAINTENANCE

Test and inspect low water cut-off(s) per manufacturer's instructions.

If the steam boiler water level is erratic and dirt & deposits appear in the water gauge glass, skim the boiler as described in Section 8.

10. TROUBLESHOOTING – SERVICE TIPS

Table 10.1: Boiler Troubleshooting

Problem	Possible Cause	Suggested Remedy
Pilot Outage	Heavy Draft Blowing across Pilot	Redirect Air Movement or Eliminate
	Plugged Pilot Orifice	Replace Orifice
	No Gas	Check Manual Pilot Valve Check Main Gas Shut-Off Valve Check Manual Meter Valve Consult Gas Company
	Ignition Control Problem	See Table 10.2 and Figure 10.1
Main Gas Valve Will Not Open	No Power	Check Power Source with Meter Check Fuses
	Defective Gas Valve	Replace
	Low Water Level in Boiler or System Causing Low Water Cut-off to Function	Check for Leaks Check Feeder (if Supplied)
	Ignition Control Problem	See Table 10.2 and Figure 10.1
	High Gas Pressure Switch Open (if Provided)	Check Switch Setting Check Manifold Gas Pressure
Burner(s) Burning with Yellow Flame	Low Gas Pressure Switch Open (if Provided)	Check Switch Setting Check Manifold Gas Pressure
	Air Adjustment Screws Turned in Too Far	Adjust Screws Out
	Low Gas Pressure in Manifold (Insufficient Air Injection)	Adjust Main Gas Pressure Regulator or Check Line Pressure
	Burner Ports Partially Closed (Rust, Dirt, Lint, etc)	Replace Burners or Clean Ports
	Insufficient Air for Combustion	Check Size of Combustion Air Openings to Room If Undersized, Correct as Required Check for Negative Pressure in Boiler Room
	Oversized Burner Orifice	Install Correct Orifice
Gas Spillage from Draft Hood Relief Opening	High Gas Pressure in Manifold	Adjust Main Gas Pressure Regulator
	Insufficient Draft - Chimney Too Low	Increase Height or Add Induced Draft Fan
	Insufficient Draft - Chimney Too Small	Replace Chimney or Add Induced Draft Fan
	Insufficient Draft - Blockage in Chimney or Vent	Repair Chimney or Vent
	Insufficient Draft - Downdraft Caused by Chimney Location with Respect to Other Buildings, Roofs, etc.	Install Chimney Cap
	Negative Pressure in Boiler Room (Due to Exhaust Fan or Duct System)	Remove Exhaust Fan or Isolate Fan From Boiler Room
	Insufficient Combustion Air Openings	Provide Correctly Sized Combustion and Ventilation Air Openings
Main Gas Valve Opens But No Gas Flows	Manual Valve Closed at Gas Train	Open Valve
	Manual Valve Closed at Meter	Open Valve
	Test Firing Valve Closed (if Provided)	Open Valve

Table 10.1 (cont'd): Boiler Troubleshooting

Problem	Possible Cause	Suggested Remedy
System or Boiler Overfilling or Excessive Make-up Water (Water Boilers)	Leaks in System	Repair Leaks or Replace Piping as Required
	Expansion tank (diaphragm or bladder type) charge pressure not right	Check Charge Pressure, Correct if Required
	Air compression tank waterlogged or diaphragm or bladder defective on expansion tank	Replace tank
	Fill valve not working or set for too high a cold fill pressure, causing relief valve to weep	Check Fill Valve, Replace if Necessary
Rapid Cycling (Water Boilers)	Temperature control differential too narrow	Adjust Control Differential
Water Hammer On Start-Up (Steam Boilers)	Sags in Steam Piping or not enough Pitch	Correct Piping Condition
	Concentric reducers causing condensate pooling	Correct Piping
	Drip trap failed closed	Replace Trap or Trap Element
	Dry returns wetted due to new boiler water line higher than old boiler	Correct Piping or Install Feed System and Traps
	No drip line on the back side of a back-pitched motorized valve	Install Drip Line and Trap
Water Hammer During Mid-Cycle (Steam Boilers)	Clogged returns on gravity system	Clean or Re-Pipe Return Line(s)
	Incorrect near-boiler piping causing wet steam to system	Correct Piping per Manual
	Trap failed open, allowing steam to enter returns	Replace Trap or Trap Element
	{Radiator Hammer} Large radiator may be vented too quickly	Use smaller Air Vent or Use Two Small Vents in Place of One Large Vent, One Mounted Higher than the Other
	Long nipple at Hartford Loop	Replace with Close Nipple
	Water leg or back slope in return line to receiver tank, causing water pocketing	Correct Piping
	Trap installed at receiver tank, causing water trapping in return	Remove Trap at Tank, Install Drip Traps and Radiator Traps where Required
	Boiler feed pump or condensate pump feed rate too fast, causing spraying into equalizer	Throttle Flow Rate
	No drip on the inlet side of a forward pitched motorized valve	Add Drip Line and Trap
	Uninsulated steam piping, causing excessive condensate loads	Insulate Steam Pipes
Water Hammer on Shut-Down (Steam Boilers)	Close nipple on Hartford Loop too high	Repipe 2" to 4" (5cm to 10cm) Below Water Line
	Uninsulated steam piping in boiler room, but system piping insulated, causing vacuum condition on shut-down	Insulate Steam Pipes
Hammering in the Boiler (Steam Boilers)	Poor circulation in the boiler due to sludge accumulation	Clean and Blowdown the Boiler
No Heat or Poor Heat Distribution in the Building (Steam Boilers)	Main vents not working	Replace Main Vents, Repiping away from End of Lines if Needed
	Drip Traps failed closed	Replace Traps or Trap Elements
	Radiator traps failed open, allowing pressurization of the returns	Replace Traps or Trap Elements
	Water legs or back slope in return lines to receiver tank, preventing air from venting out receiver vent	Correct Piping
	Boiler pressure too high, causing air vents to lock up or blowing water loop seals	Reduce Operating Pressure

Table 10.1 (cont'd): Boiler Troubleshooting

Problem	Possible Cause	Suggested Remedy
System or Boiler Overfilling or Flooding (Steam Boilers)	New boiler water content smaller than old boiler	Install Boiler Feed System with Receiver Tank Large enough for Condensate
	Boiler water feed rate or pump rate too fast causing water level to collapse (due to collapse of steam bubbles in boiler water)	Reduce Feed Rate
	Foaming, priming or surging due to poor water quality	Clean the Boiler
Excessive Water Level Bounce (Steam Boilers)	Poor water quality, causing foaming and surging	Clean the Boiler
	Incorrect near-boiler piping, such as undersized or incorrectly placed risers	Pipe per Manual
	Boiler water feed rate or pump rate too fast	Reduce Feed Rate
Rapid Cycling (Steam Boilers)	Air vents or traps not venting air, preventing steam from getting to radiation and pressurizing the air pocket	Replace Vents or Traps
	Pressure differential on pressure control too close	Adjust Control Differential
	Nuisance outages of water level control due to boiler water level bounce	See Excessive Water Level Bounce Above

Table 10.2: Capable Controls Series 5 Ignition Module – Sequence of Operation and Error Codes

<u>Trial for Ignition</u> – 90 seconds, 5 minute wait between trials for ignition.		
<u>LED Indications, Normal Operation</u>		
Green, blinking rapidly	Trial for ignition	
Green, on solid	Flame detected, pilot/main burners on	
Green, 1/2 sec on, 1/2 sec off	Wait time between trials for ignition	
<u>LED Indications, Error Operation</u>		
Upon detection of a fault by the ignition module's internal diagnostics, sparking is turned off and pilot and/or main gas valve(s) are closed. See LED error codes below. To reset module and clear error, interrupt call for heat (power).		
<u>Red Flashes</u>	<u>Error Definition</u>	<u>Suggested Remedy</u>
1 flash	N/A (non-retry models only)	Not applicable
2 flashes	Flame sense stuck on	If pilot lit with all power off, replace gas valve. Otherwise, replace module.
3 flashes	Pilot/Main relay failure	Replace module
4 flashes	Repetitive flame loss error	Check gas pressure, flame size, electrode position.
5 flashes	N/A (models with flame rollout)	Not applicable
6 flashes	N/A (models with APS sensor)	Not applicable
7 flashes	Internal control error	Replace module
Solid Red	Line Voltage/Freq Error	Verify voltage and frequency of incoming power.
See also Figure 10.1, Troubleshooting Flow Chart.		

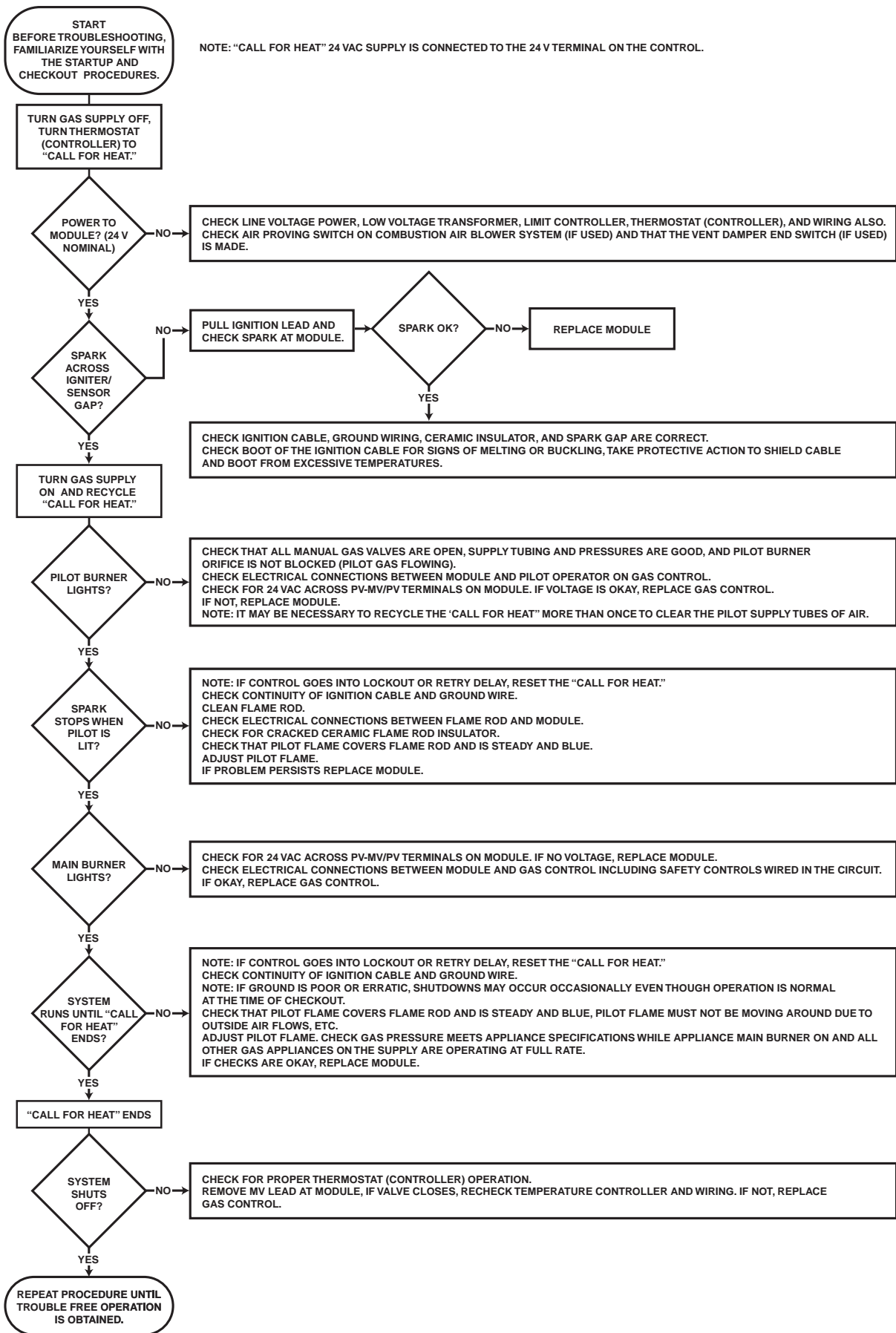

Figure 10.1: Ignition System Troubleshooting Guide

11. BOILER DIMENSIONS & RATINGS

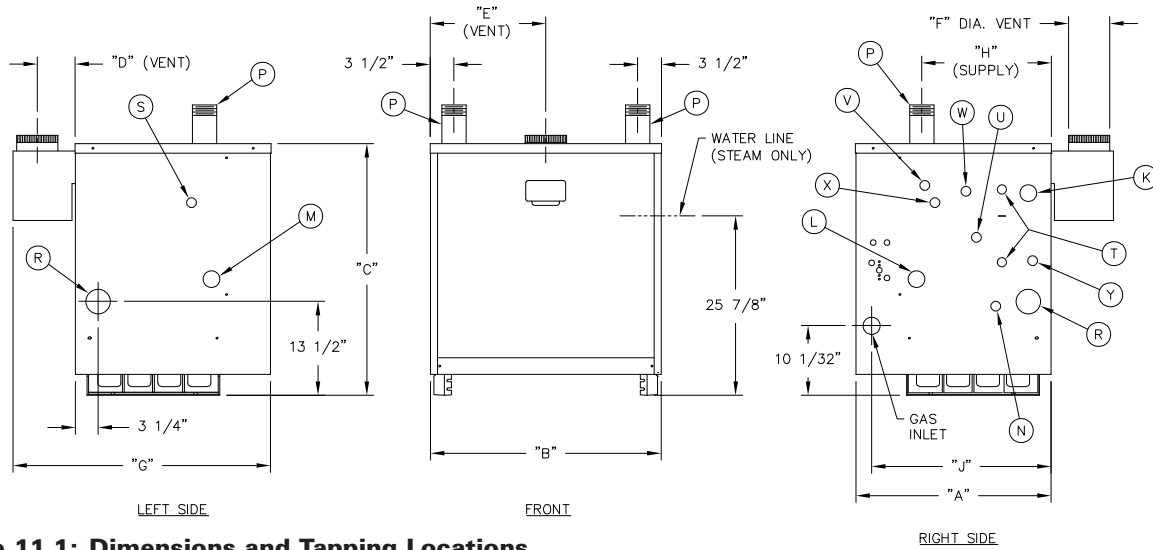

Figure 11.1: Dimensions and Tapping Locations

Table 11.1: Tapping Sizes & Functions

SERIES 63/64™ TAPPING SIZES & FUNCTIONS			
Tap ID	Size NPT	Steam	Water
K	1-1/4"	Skim Tapping*	Skim Tapping*
L	1"	Tank Supply/Limit	N/A
M	1"	Tank Return	N/A
N	3/4"	Boiler Drain	Boiler Drain
P	3"	Supply	Supply
R	2-1/2"	Return	Return
S	3/4"	Safety Valve*	Relief Valve*
T	1/2"	Gauge Glass	N/A
U	3/4"	Primary Probe Low Water Cut-Off	N/A
V	3/4"	N/A or Primary Limit (9-12)	N/A or Secondary Limit (9-12)
W	3/4"	Press Gauge or Secondary Limit (9-12)	Press/Temp Gauge or Primary Limit (9-12)
X	3/4"	Primary Limit or Press Gauge (9-12)	Primary Limit or Temp/Press Gauge (9-12)
Y	3/4"	Secondary Probe Low Water Cut-Off	N/A

*For relief valve larger than 3/4", use "K" boiler skim tapping. Do not increase the pipe size between the boiler and the valve.

Table 11.2: Dimensions

SERIES 63/64™ BOILER DIMENSIONS									
Boiler Model Number	Jacket Depth "A"	Jacket Width "B"	Jacket Height "C"	Rear of Jkt. to c/l of Vent "D"	Left of Jkt. to c/l of Vent "E"	Vent Size Dia. "F"	Overall Depth "G"	Rear of Jkt. to c/l of Supply "H"	Rear of Jkt. to c/l of Gas Inlet "J"
63-03L	28-1/8"	16-1/8"	36-3/8"	5-5/8"	8-1/16"	6"	37-1/4"	18-11/16"	25-7/8"
63-03	28-1/8"	16-1/8"	36-3/8"	5-5/8"	8-1/16"	6"	37-1/4"	18-11/16"	25-7/8"
63-04L	28-1/8"	20-3/8"	36-3/8"	5-1/8"	10-3/16"	7" or 6"*	37-1/4"	18-11/16"	25-7/8"
63-04	28-1/8"	20-3/8"	36-3/8"	5-1/8"	10-3/16"	7" or 6"*	37-1/4"	18-11/16"	25-7/8"
63-05L	28-1/8"	24-5/8"	36-3/8"	6-5/8"	12-5/16"	8"	39-1/4"	18-11/16"	25-7/8"
63-05	28-1/8"	24-5/8"	36-3/8"	6-5/8"	12-5/16"	8"	39-1/4"	18-11/16"	25-7/8"
63-06	28-1/8"	28-7/8"	36-3/8"	6-1/8"	14-7/16"	9"	39-1/4"	18-11/16"	25-7/8"
64-07	28-1/8"	33-1/8"	36-3/8"	6-1/8"	16-9/16"	9"	39-1/4"	18-11/16"	25-7/8"
64-08	30-1/8"	37-3/8"	36-3/8"	7-1/2"	18-11/16"	10"	43-1/8"	18-15/16"	26-1/8"
64-09	30-1/8"	41-5/8"	36-3/8"	7-1/2"	20-13/16"	10"	43-1/8"	18-15/16"	26-1/8"
64-10	30-1/8"	45-7/8"	36-3/8"	8-1/2"	22-15/16"	12"	45-1/8"	18-15/16"	26-1/8"
64-11	30-1/8"	50-1/8"	36-3/8"	8-1/2"	25-1/16"	12"	45-1/8"	18-15/16"	26-1/8"
64-12	30-1/8"	54-3/8"	36-3/8"	8-1/2"	27-3/16"	12"	45-1/8"	18-15/16"	26-1/8"

*Draft hood outlet and vent damper are 7" diameter on 63-04L and 63.04. These models are also certified in USA with 6" vent using vent reducer provided in draft hood carton. Install reducer on outlet of vent damper.

Table 11.3: Series 63™ Boiler Ratings

Series 63™									Water Content		Approx. Shipping Weight, lb
Boiler Model	Input, MBH	Heating Capacity ³		Net Ratings ¹			AFUE ²		Water, gal	Steam, gal	
		Water, MBH	Steam, MBH	Steam, sqft	Steam, MBH	Water, MBH	Water, %	Steam, %			
63-03L	88.5	73	74	233	56	63	82.4	83.0	13.2	9.3	465
63-03	118.0	99	98	308	74	86	83.5	82.6	13.2	9.3	465
63-04L	147.5	123	123	383	92	107	82.7	82.6	15.6	10.8	576
63-04	177.0	148	147	458	110	129	83.4	82.4	15.6	10.8	576
63-05L	206.5	172	171	533	128	150	82.9	82.3	18.0	12.4	700
63-05	236.0	198	196	613	147	172	83.3	82.2	18.0	12.4	700
63-06	287.5	241	238	746	179	210	83.2	82.0	20.4	13.9	812

1. Net Ratings are based on DOE Heating Capacity less an allowance for normal piping and pickup as determined by the Testing and Rating Standard for Low Pressure Cast Iron Heating Boilers of the Hydronics Institute. Water ratings are based on a piping and pickup factor of 1.15. Steam ratings are based on a piping and pickup factor of 1.33. Consult PB Heat before selecting a boiler for gravity hot water installations or for installations having unusual piping and pickup requirements such as exposed piping, night set back, etc. Ratings shown are for elevations up to 2,000 feet. For elevations above 2,000 feet, ratings should be reduced at the rate of 4% for each 1,000 feet above sea level.
2. Heating Capacity and Annual Fuel Utilization Efficiency (AFUE) ratings are based on U.S. Government tests. Before purchasing this appliance, read important information about its estimated annual energy consumption or energy efficiency rating that is available from your retailer.

Table 11.4: Series 64™ Boiler Ratings

Series 64™										Water Content		Approx. Shipping Weight, lb	
Boiler Model	Input, MBH	Gross Output ²		Net Ratings ¹			Thermal Efficiency		Combustion Efficiency ²		Water, gal		Steam, gal
		Water, MBH	Steam, MBH	Steam, sqft	Steam, MBH	Water, MBH	Water, %	Steam, %	Water, %	Steam, %			
64-07	345	286	274	858	206	249	81.0	79.4	83.0	82.5	22.8	15.5	945
64-08	399	331	318	996	239	288	81.0	79.6	83.0	82.5	25.2	17.0	1081
64-09	460	382	367	1146	275	332	81.0	79.7	83.0	82.5	27.6	18.6	1218
64-10	518	430	413	1292	310	374	81.0	79.8	83.0	82.5	30.0	20.1	1354
64-11	575	477	459	1433	344	415	81.1	79.8	83.0	82.5	32.4	21.7	1490
64-12	633	525	506	1583	380	457	81.0	79.9	83.0	82.4	34.8	23.2	1527

1. Net Ratings are based on Gross Output less an allowance for normal piping and pickup as determined by the Testing and Rating Standard for Low Pressure Cast Iron Heating Boilers of the Hydronics Institute. Water ratings are based on a piping and pickup factor of 1.15. Steam ratings are based on a piping and pickup factor of 1.33. Consult PB Heat before selecting a boiler for gravity hot water installations or for installations having unusual piping and pickup requirements such as exposed piping, night set-back, etc. Ratings shown are for elevations up to 2,000 feet. For elevations above 2,000 feet, ratings should be reduced at the rate of 4% for each 1,000 feet above sea level.
2. Combustion efficiency and gross output are determined in accordance with ANSI Z21.13 / CSA 4.9, *Gas-Fired Low-Pressure Steam and Hot Water Boilers*.

Table 12.1

	Description	Quantity Required	Stock Code
1	Intermediate Section – w/out Draw Lugs	–	90028
2	Intermediate Section – w/ Draw Lugs (64)	–	90029
3	Right Hand Section	–	90030
4	Left Hand Section	–	90031
5	Draw Rod 5/8"-11 x 8" (64)	–	7797
6	Draw Rod Nut 5/8"-11 (64)	–	51567
7	Draw Rod Washer (64)	–	7289
8	2" Push Nipple	–	51543
9	6" Push Nipple	–	51546
10	High Temperature Sealing Rope 1/2"	–	51211
–	63-03L Block Assembly	–	90684
–	63-03 Block Assembly	–	90684
–	63-04L Block Assembly	–	90685
–	63-04 Block Assembly	–	90685
–	63-05L Block Assembly	–	90686
–	63-05 Block Assembly	–	90686
–	63-06 Block Assembly	–	90687
–	Left Hand 64-07 Split Block	–	90904
–	Right Hand 64-07 Split Block	–	90906
–	Left Hand 64-08 Split Block	–	90904
–	Right Hand 64-08 Split Block	–	90907
–	Left Hand 64-09 Split Block	–	90904
–	Right Hand 64-09 Split Block	–	90908
–	Left Hand 64-10 Split Block	–	90905
–	Right Hand 64-10 Split Block	–	90907
–	Left Hand 64-11 Split Block	–	90905
–	Right Hand 64-11 Split Block	–	90908
–	Left Hand 64-12 Split Block	–	90905
–	Right Hand 64-12 Split Block	–	90909
11	Base Front Panel – 63-03	–	50324
	Base Front Panel – 63-04	–	50325
	Base Front Panel – 63-05	–	50326
	Base Front Panel – 63-06	–	50327
	Base Front Panel – 64-07	–	50328
	Base Front Panel – 64-08	–	50329
	Base Front Panel – 64-09	–	50330
	Base Front Panel – 64-10	–	50331
	Base Front Panel – 64-11	–	50332
	Base Front Panel – 64-12	–	50333
12	Base Rear Panel – 63-03	–	61180
	Base Rear Panel – 63-04	–	61181
	Base Rear Panel – 63-05	–	61182
	Base Rear Panel – 63-06	–	61183
	Base Rear Panel – 64-07	–	61184
	Base Rear Panel – 64-08	–	61185
	Base Rear Panel – 64-09	–	61186
	Base Rear Panel – 64-10	–	61187
	Base Rear Panel – 64-11	–	61188
	Base Rear Panel – 64-12	–	61189

	Description	Quantity Required	Stock Code	
13	Burner Access Panel – 63-03	–	50271	
	Burner Access Panel – 63-04	–	50272	
	Burner Access Panel – 63-05	–	50273	
	Burner Access Panel – 63-06	–	50274	
	Burner Access Panel – 64-07	–	50275	
	Burner Access Panel – 64-08	–	50276	
	Burner Access Panel – 64-09	–	50277	
	Burner Access Panel – 64-10	–	50278	
	Burner Access Panel – 64-11	–	50279	
	Burner Access Panel – 64-12	–	50280	
	14	Burner Tray Rear Support – 63-03	–	50300
		Burner Tray Rear Support – 63-03L	–	50301
Burner Tray Rear Support – 63-04		–	50302	
Burner Tray Rear Support – 63-04L		–	50303	
Burner Tray Rear Support – 63-05		–	50304	
Burner Tray Rear Support – 63-05L		–	50305	
Burner Tray Rear Support – 63-06		–	50306	
Burner Tray Rear Support – 63-07		–	50307	
Burner Tray Rear Support – 63-08		–	50308	
Burner Tray Rear Support – 63-09		–	50309	
Burner Tray Rear Support – 63-10		–	50310	
Burner Tray Rear Support – 63-11		–	50311	
Burner Tray Rear Support – 63-12	–	50312		
15	Burner Tray Left Side Rail	–	50296	
	Burner Tray Right Side Rail	–	50295	
16	Burner – 63-03L	2	50192	
	Burner – 63-03	3	50192	
	Burner – 63-04L	4	50192	
	Burner – 63-04	5	50192	
	Burner – 63-05L	6	50192	
	Burner – 63-05	7	50192	
	Burner – 63-06	9	50192	
	Burner – 64-07	11	50192	
	Burner – 64-08	13	50192	
	Burner – 64-09	15	50192	
	Burner – 64-10	17	50192	
	Burner – 64-11	19	50192	
Burner – 64-12	21	50192		
17	Burner with Pilot Bracket (Spark)	–	50163	

Part numbers may be subject to change without notice.

Table 12.2

	Description	Quantity Required	Stock Code	
18	Gas Valve – NAT 63-05/06 Honeywell VR8304M-4002	-	50589	
	Gas Valve – NAT 64-07, 64-08 Honeywell VR8304M-4002	-	50589	
	Gas Valve – NAT 63-03, 63-04 Honeywell VR8204A-2001	-	50583	
	Gas Valve – NAT 64-09/64-12 7000DERHC Robert Shaw	-	50247	
	Gas Valve – LP 63-05, 63-06 Honeywell VR8304M-4010	-	50590	
	Gas Valve – LP 64-07, 64-08 Honeywell VR8304P-4314	-	50724	
	Gas Valve – LP 64-09 thru 64-12 Honeywell VR8304P-4314	-	50724	
	Gas Valve – LP 63-03, 63-04 Honeywell VR8204A-2183	-	50584	
	19	Pilot Assembly NAT 63/64 Honeywell Q348A-1002	-	50558
		Pilot Assembly LP 63/64 Honeywell Q348A-1358	-	51814
- Ignition Cable Honeywell 394800-30		-	50640	
- Vent Safety Switch (3L, 3, 4L) 1 NT08L-5621-210°F		-	50040	
- Vent Safety Switch (4-12; not 4L) 1 NT08L-5621-230°F		-	50041	
- Flame Rollout Switch 176°C		-	51587	
- Ignition Control (non-CSD)		-	50767	
- Ignition Control (CSD)		-	50732	
20		Gas Manifold – 63-03L	-	50265
		Gas Manifold – 63-04	-	50266
	Gas Manifold – 63-04L	-	50267	
	Gas Manifold – 63-05	-	50268	
	Gas Manifold – 63-05L	-	50269	
	Gas Manifold – 63-06	-	50270	
	Gas Manifold – 64-07 Assembly Kit	-	90411	
	Gas Manifold – 64-08 Assembly Kit	-	90412	
	Gas Manifold – 64-09 Assembly Kit	-	90413	
	Gas Manifold – 64-10 Assembly Kit	-	90414	
21	Flue Collector – 63-03	-	50281	
	Flue Collector – 63-03L	-	50282	
	Flue Collector – 63-04	-	50283	
	Flue Collector – 63-04L	-	50284	
	Flue Collector – 63-05	-	50285	
	Flue Collector – 63-05L	-	50286	
	Flue Collector – 63-06	-	50287	
	Flue Collector – 64-07	-	50288	
	Flue Collector – 64-08	-	50289	
	Flue Collector – 64-09	-	50290	
Flue Collector – 64-10	-	50291		
Flue Collector – 64-11	-	50292		
Flue Collector – 64-12	-	50293		

	Description	Quantity Required	Stock Code
22	Draft Hood – 63-03	-	50252
	Draft Hood – 63-04	-	50347
	Draft Hood – 63-05	-	50256
	Draft Hood – 63-06	-	50257
	Draft Hood – 64-07	-	50258
	Draft Hood – 64-08	-	50259
	Draft Hood – 64-09	-	50260
	Draft Hood – 64-10	-	50261
	Draft Hood – 64-11	-	50262
	Draft Hood – 64-12	-	50263
23	Insulation Board	-	7956
Conversion Kits Natural to LP Gas			
-	SPRK 63	-	90070
-	SPRK 64	-	90071
Conversion Kit LP to Natural Gas			
-	SPRK 63	-	90069
-	SPRK 64-07, 64-08	-	90051
-	SPRK 64-09, 64-12	-	90052
Vent Dampers			
-	63-03 – Effikal-RVGP-6BK – 6"	-	90613
-	63-04 – Effikal-RVGP-7BK – 7"	-	90614
-	63-05 – Effikal-RVGP-8BK – 8"	-	90615
-	63-06 – Effikal-RVGP-9BK – 9"	-	90417
-	64-07 – Effikal-RVGP-9BK – 9"	-	50167
-	64-08 Thru 64-09 – Effikal-RVGP-1 0BK – 10"	-	50168
-	64-10 Thru 64-12 – Effikal-RVGP-1 0BK – 12"	-	90616
Jackets			
-	63-03L	-	90645
-	63-03	-	90645
-	63-04L	-	90646
-	63-04	-	90646
-	63-05L	-	90647
-	63-05	-	90647
-	63-06	-	90648
-	64-07	-	90649
-	64-08	-	90650
-	64-09	-	90651
-	64-10	-	90652
-	64-11	-	90653
-	64-12	-	90654
-	Limit Control, Steam – PA404A	-	50549
-	Limit Control, Steam Manual Reset – L4079B	-	50681
-	Brass Siphon – 63-03 Thru 64-08	-	6667
-	Brass Siphon, Long – 64-09 Thru 64-12	-	6665
-	Limit Control, Water – Beckett 7600B	-	50335
-	Immersion Well, Beckett 7600T	-	50341
-	Immersion Sensor, Beckett 7600P	-	50339
-	Limit Control w/ Sensor, Water – Hydrolevel 3200	-	50334
-	Immersion Well, Hydrolevel	-	50723
-	Limit Control, Water Manual Reset – L4006E	-	50570
-	Pressure Gauge – Steam	-	51325
-	Temperature/Pressure Gauge – Water	-	51324
-	Transformer, Steam – 40VA	-	50787

Series 63/64™

Gas Boilers

Installation, Operation & Maintenance Manual

TO THE INSTALLER:

This manual is the property of the owner and must be affixed near the boiler for future reference.

TO THE OWNER:

This boiler should be inspected annually by a Qualified Service Agency.



PeerlessBoilers.com

PB HEAT, LLC

131 S. CHURCH STREET • BALLY, PA 19503