

# HYDROSTAT®

## MODEL 3150

**Combination Low Water  
Cut-Off & Universal  
Temperature Limit Control  
for Oil-Fired Boilers**

PATENT NO. 7,891,572

## INSTALLATION INSTRUCTIONS and OPERATING MANUAL

- **Replaces Common Aquastat® Models** – Can be installed on existing immersion wells to replace both cold-start and triple-action Aquastats®. Industry standard wiring designations make change-outs quick and easy.
- **Digital Display** – Easy to read LED continually displays boiler temperature. Also displays temperature limit and differential settings during adjustment.
- **Easy to Set** – Dials for setting temperature limits and differentials eliminate complicated programming.
- **Thermal Pre-Purge Feature** – Conserves fuel and meets 2012 DOE regulations by circulating latent heat in the boiler to the heating zone before firing the burner.

\*Aquastat is a registered trademark of Honeywell International, Inc.

## Dual Function Design

### Temperature Limit Control

Designed for cold start and tankless coil boilers.

### Low Water Cut-Off

Provides protection against potentially dangerous low water conditions when installed with the Hydrolevel Electro-Well™ (see page 2 for details).



**WARNING** **Electrical shock hazard.** To prevent electrical shock, death or equipment damage, disconnect power supply before installing or servicing control. Only qualified personnel may install or service this control in accordance with local codes and ordinances. Read instructions completely before proceeding.



**CAUTION** To prevent serious burns, boiler should be thoroughly cooled before installing or servicing control.



**WARNING** **Frozen pipes/water damage.** Central heating systems are prone to shut down as a result of power or fuel outages, safety related fault conditions or equipment failure. Installation of freeze protection monitoring or other precautions is recommended for unattended dwellings in climates subject to sustain below-freezing temperatures.

**HYDROLEVEL  
COMPANY**

83 Water Street • New Haven, CT 06511 • Phone (203) 776-0473 • FAX (203) 773-1019 • [www.hydrolevel.com](http://www.hydrolevel.com)

## IMMERSION WELLS

HydroStat can be installed on an existing immersion well already in the boiler or on a Hydrolevel Electro-Well™ (sold separately). The low water cut-off function is automatically activated when installed on an Electro-Well™.

**IMPORTANT:** The control will not provide low water cut-off protection when installed on a standard immersion well.

**NOTE:** Do not use heat-conducting grease.

### HydroStat installed with Hydrolevel Electro-Well™

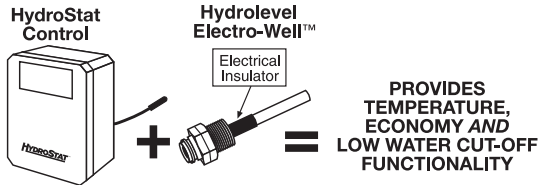

**IMPORTANT:** For proper operation of the low water cut-off function, there must be a minimum of 1/2" clearance between the copper well tube and any surface within the boiler.

See Electro-Well models on page 11.

### HydroStat installed with standard immersion well

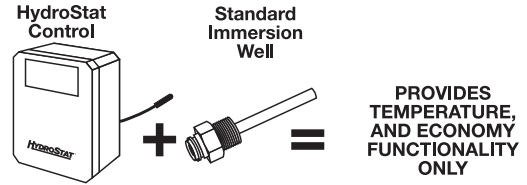

**NOTE:** When installed on a standard immersion well, the "LWCO Active" LED will not illuminate.

## MOUNTING THE CONTROL

**IMPORTANT** Make sure that the immersion well or Electro-Well™ is installed in the boiler manufacturer's designated temperature limit control tapping.

**NOTE:** If installing an Electro-Well, pipe sealing compound should be used. Teflon tape is not recommended.

**STEP 1** Two mounting positions are available on the back of the control (Fig. 1). Select which of the two positions (2 knockouts) is best for the location of the control. Remove the knockout.

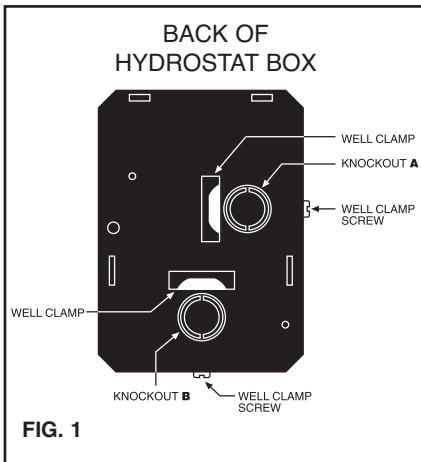

**STEP 2** Place control on the well. While holding box against well nut, tighten well clamp screw. (Fig. 2)

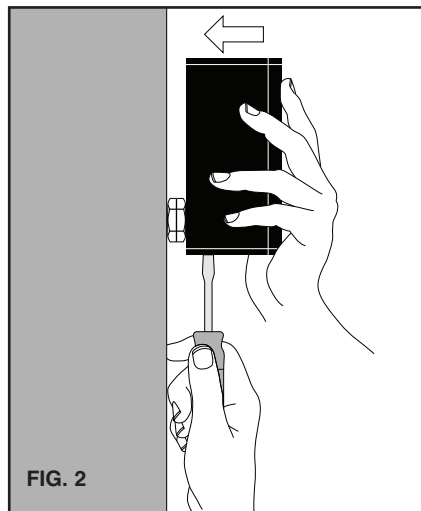

**STEP 3** Insert sensor ALL THE WAY into well through the knockout (A or B) you have chosen. (Fig. 3)

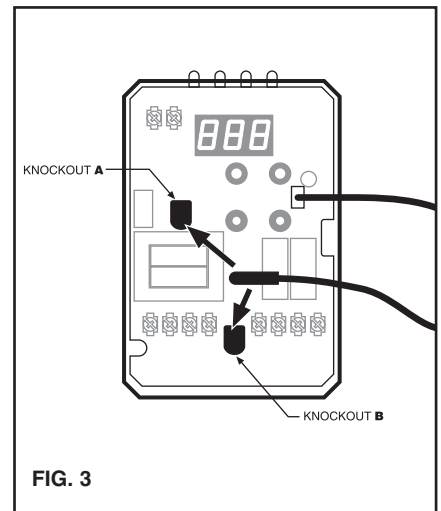

**NOTE:** In the case of space restrictions, the Fuel Smart HydroStat control may be mounted in a horizontal orientation without any loss of function. Hydrolevel recommends vertical mounting, when possible, for proper orientation of LED display.

**REMOTE MOUNTING KITS** are available separately for mounting the Fuel Smart HydroStat control box in a remote location. Each kit includes mounting hardware and a remote sensor. See page 12 for kit options.

# WIRING

**WARNING** Electrical shock hazard. To prevent electrical shock, death or equipment damage, disconnect power supply before installing or servicing this control.

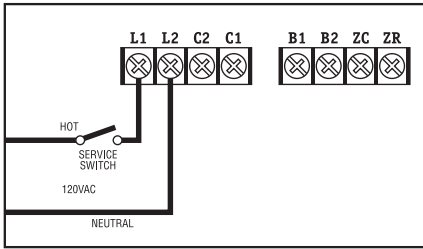

**STEP 1** Connect 120 VAC Hot to terminal L1. Connect 120 VAC Neutral to terminal L2. Disconnect means and overload protection as required (provided by others).

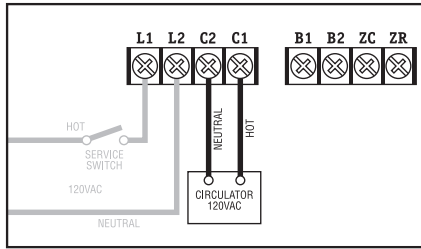

**STEP 2** Connect the circulator to C1 and C2. (C2 is neutral.)

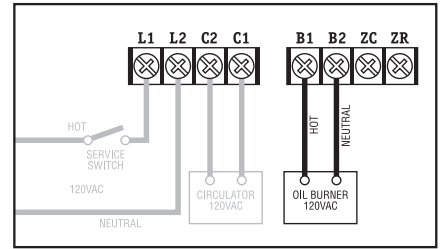

**STEP 3** Connect the burner circuit to B1 and B2. (B2 is neutral.)

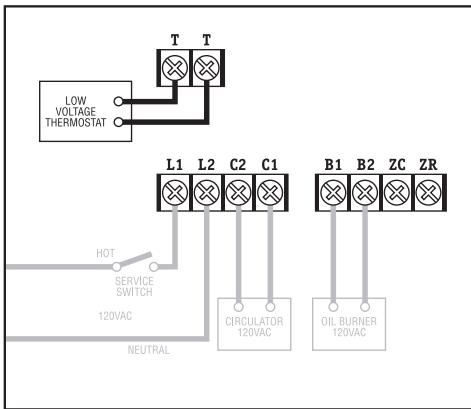

**STEP 4** Connect the thermostat to T and T.

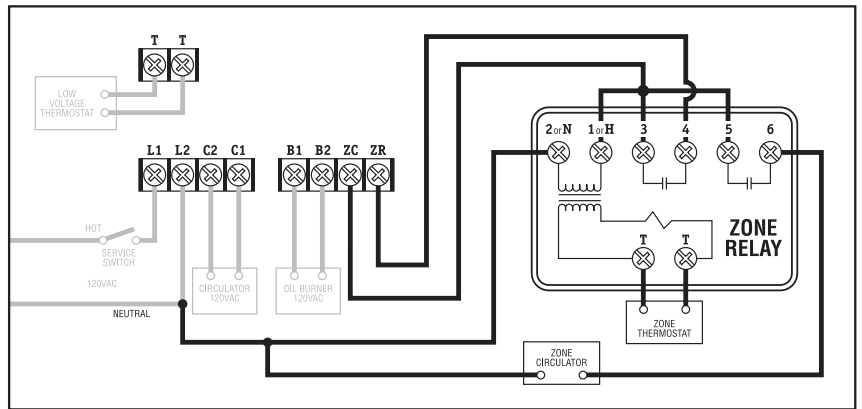

**Multi-Zones** Adding additional zones.

# SCHEMATIC/LADDER DIAGRAM

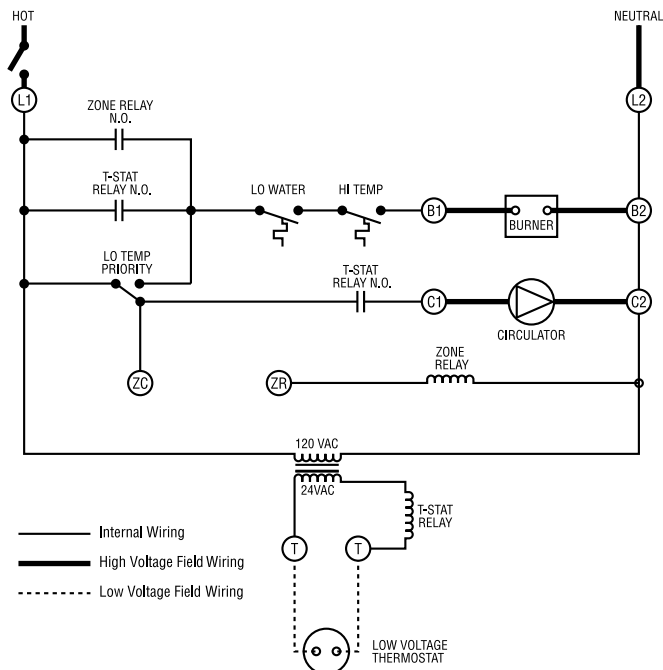

# SETTING THE CONTROL

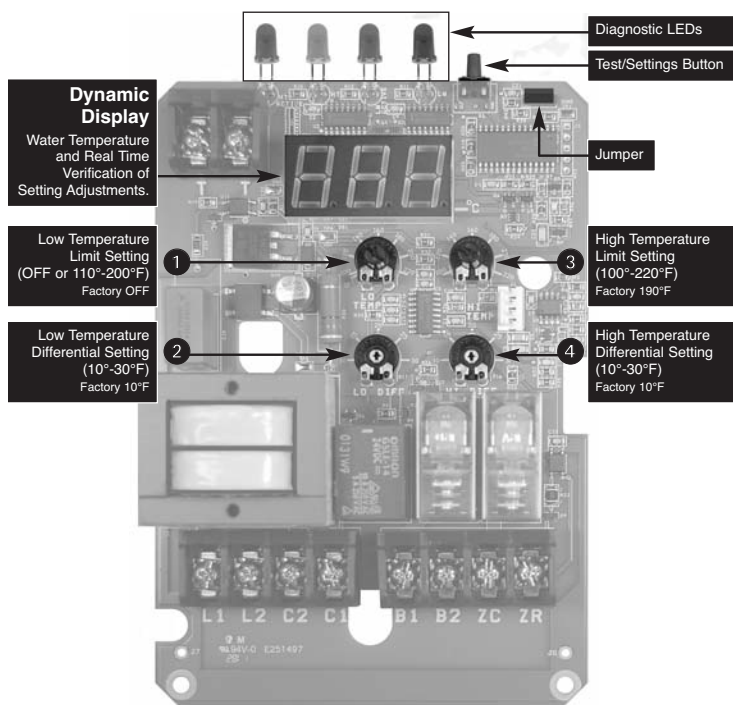

**NOTE:** Be careful not to select overlapping temperature settings. For example: If the HIGH TEMPERATURE LIMIT is set at 190°F with a HIGH TEMPERATURE DIFFERENTIAL set at 20°F, then the LOW TEMPERATURE LIMIT needs to be set at 170°F (190°F - 20°F = 170°F) or below.

**IMPORTANT:** To prevent flue gas condensation and reduce fatigue caused by thermal cycling on conventional (non-condensing) boilers, both HIGH and LOW LIMIT set points should be 150°F or above (Limit Setting - Differential Setting  $\geq$  150°F). Boiler manufacturer's temperature requirements supercede these recommendations.

## To set COLD START operation

*Operates on call for heat only.*

- 1 **Low Temperature Limit**  
Make sure Low Temperature Limit is turned fully counter-clockwise (OFF position).
- 2 **Low Temperature Differential**  
No change is required.
- 3 **High Temperature Limit**  
(factory setting = 190°F)  
Adjust setting until desired temperature is displayed.
- 4 **High Temperature Differential**  
(factory setting = 10°F)  
Using a small screwdriver, adjust setting until desired differential is displayed.

## To set WARM START operation

*Maintains temperature for domestic hot water.*

- 1 **Low Temperature Limit**  
Adjust setting until desired temperature is displayed. Prior to adjusting, remove the jumper located at the top right corner of the circuit board (not equipped on all units).  
**IMPORTANT: If low limit temperature cannot be set above 140°F, remove jumper.**
- 2 **Low Temperature Differential**  
Using a small screwdriver, adjust setting until desired differential is displayed.
- 3 **High Temperature Limit**  
(factory setting = 190°F)  
Adjust setting until desired temperature is displayed.
- 4 **High Temperature Differential**  
(factory setting = 10°F)  
Using a small screwdriver, adjust setting until desired differential is displayed.

# OPERATION

## COLD START

Low Limit Switch = OFF

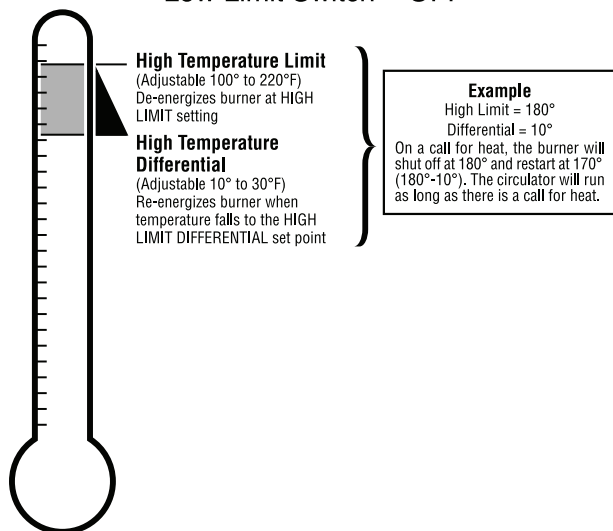

## WARM START

(maintains temperature for domestic hot water)

Low Limit Switch = ON

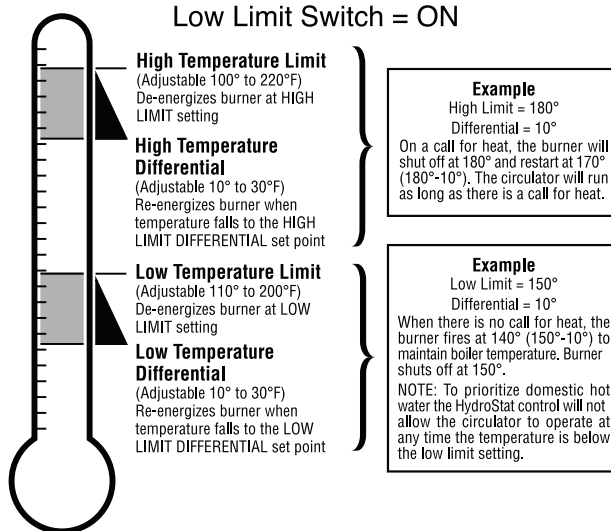

## OPTIONAL FEATURES

NOTE: The Program Mode –  $P_{r-d}$  – is accessed by turning the LO TEMP dial to a position just above OFF.

### Thermal Pre-Purge

---

Thermal Pre-Purge is designed to maximize boiler efficiency. When activated, the control will supply latent heat that may remain in the boiler from a previous run cycle to the heating zone that is now calling. The control monitors how quickly the boiler temperature is declining and activates the burner only when it determines that the latent heat is insufficient to satisfy the call. During the purge cycle the display will indicate  $P_{Lr}$ . This feature works with single-zone and multi-zone heating systems utilizing circulators or zone valves. No change in wiring is needed.

#### **To activate Thermal Pre-Purge**

1. Turn the LO TEMP dial to access the Program Mode – indicated in the display as  $P_{r-d}$
2. Turn the HI TEMP dial to select feature  $l$
3. Push the Test/Settings Button to turn Thermal Pre-Purge  $on$  or  $OFF$
4. Reset LO TEMP and HI TEMP settings to desired temperatures (see page 4)

### Degrees Fahrenheit or Celsius

---

The control has the ability to operate in degrees Fahrenheit or Celsius. When operating in Celsius, a  $C$  will appear in the display next to the temperature whenever the temperature is below 100 degrees.

#### **To change between degrees Fahrenheit and degrees Celsius**

1. Turn the LO TEMP dial to access the Program Mode – indicated in the display as  $P_{r-d}$
2. Turn the HI TEMP dial to select feature  $C$
3. Push the Test/Settings Button to  $C$  for Celsius or  $F$  for Fahrenheit
4. Reset LO TEMP and HI TEMP settings to desired temperatures (see page 4)

### Manual Reset Low Water Cut-Off

---

The low water cut-off operation on the HydroStat can be set to operate in automatic (default) or manual reset mode. When in manual reset mode, the control will shut-down the burner immediately when a low water condition is detected. If the low water condition is sustained for 30 seconds, the low water light will blink, indicating that the control has locked out the burner. The control can only be reset by pushing the Test/Settings button on the top of the control. The manual reset feature meets CSD-1 code requirements.

**IMPORTANT:** The system must be checked by a qualified heating professional prior to resuming operation.

 **WARNING: DO NOT ADD WATER UNTIL THE BOILER HAS FULLY COOLED.**

#### **To activate Manual Reset LWCO mode**

1. Turn the LO TEMP dial to access the Program Mode – indicated in the display as  $P_{r-d}$
2. Turn the HI TEMP dial to select feature  $3$
3. Push the Test/Settings Button to  $A$  for Automatic Reset Mode or  $B$  for Manual Reset Mode
4. Reset LO TEMP and HI TEMP settings to desired temperatures (see page 4)

**To Test the Manual Reset Feature:** Press and hold the Test/Settings button located on the top of the control for 30 seconds to simulate a low water condition. After 30 seconds, the Low Water light will blink indicating that the control is locked out. To reset the lock-out condition, press the Test/Settings button momentarily.

MORE OPTIONAL FEATURES ON NEXT PAGE

## Circulator Activation Options

When in the default mode, the HydroStat activates the circulator (C1/C2 contacts) on calls to **TT**. The control can be programmed to activate the circulator on calls to **ZC/ZR** in place of, or in addition to, calls to **TT**.

### To change how the Circulator is activated

1. Turn the LO TEMP dial to access the Program Mode – indicated in the display as **Pr**
2. Turn the HI TEMP dial to select feature **4**
3. Push the Test/Settings Button to select between the following options:
  - A** - Circulator on **TT** call only
  - B** - Circulator on **ZC/ZR** call only
  - C** - Circulator on both **TT** & **ZC/ZR** calls
4. Reset LO TEMP and HI TEMP settings to desired temperatures (see page 4)

## Restore Factory Default Settings

### To restore all features to the factory default settings (see following chart for default settings)

1. Turn the LO TEMP dial to access the Program Mode – indicated in the display as **Pr**
2. Turn the HI TEMP dial to select feature **dEF**
3. Push the Test/Settings Button to **4** to reset all features to the default settings.
4. Reset LO TEMP and HI TEMP settings to desired temperatures (see page 4)

Dial Setting	Feature	Options	Description	Default Setting
1	Thermal Pre-Purge	OFF ON	Purge Inactive Purge Active	OFF (see note below)
2	Fahrenheit or Celsius	F C	Degrees Fahrenheit Degrees Celsius	F
3	LWCO Manual or Automatic Reset	A B	Automatic Reset Manual Reset	A
4	Circulator Options	A B C	Circulator operation on TT call only Circulator operation on ZC/ZR call only Circulator operation on call from either	A
5	<i>Not available on this control</i>			
6	<i>Not available on this control</i>			
dEF	Restore Factory Defaults	4 n	Restore Defaults Do Not Restore Defaults	n

NOTE: On OEM equipment, Thermal Pre-Purge will be factory set to **ON** to meet D.O.E. regulations.

## LED LEGEND

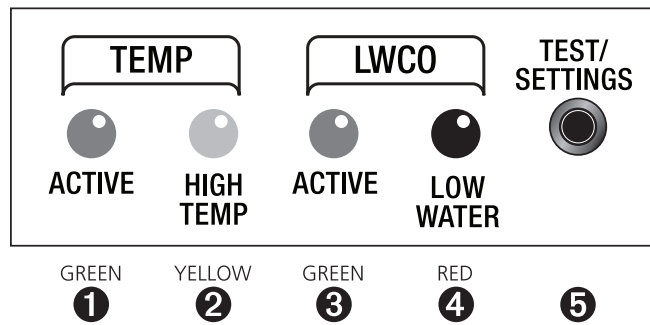

**1 TEMP ACTIVE** Indicates that the HydroStat control is powered and that the temperature function is active.

**2 TEMP HIGH TEMP** Illuminates when the boiler water temperature reaches the high limit setting. It will remain lit until the water temperature falls below the high limit setting less the differential setting. The HydroStat control will prevent burner operation while this LED is on. **NOTE:** This LED illuminates regularly during normal boiler operation.

**3 LWCO ACTIVE** Indicates that the low water cut-off (LWCO) function of the HydroStat control is active. When the control is installed with a Hydrolevel Electro-Well, this LED will be on at all times when the control is powered.

**NOTE:** If the control was installed with a well other than the Electro-Well, this LED will not illuminate. This indicates that the control is providing temperature function only.

**4 LWCO LOW WATER** Indicates that the boiler is in a low water condition. The HydroStat control will prevent burner operation during this condition. If the LOW WATER light is blinking, the control has been programmed to provide lock-out protection in the event a low water condition is detected (see Manual Reset Low Water Cut-Off on page 5). Pressing the TEST/SETTINGS button will reset the control.

**IMPORTANT:** The system must be checked by a qualified heating professional prior to resuming operation.



**WARNING: ALLOW THE BOILER TO FULLY COOL BEFORE ADDING WATER.**

**5 TEST/SETTINGS Button**

**To Test Low Water Cut-Off:** Press and hold the Test/Settings button for 5 seconds. The display will read LCO.

**LWCO TEST LCO**

The red Low Water light should illuminate and the burner circuit (B1 and B2) should de-energize. **NOTE:** The control must be installed with a Hydrolevel Electro-Well for low water cut-off functionality (see page 1 for more details).

**To View Current Settings:** Press and release the Test/Settings Button in short intervals to sequentially display the following settings:

HIGH LIMIT SETTING *HL*  
 ▼  
 HIGH DIFFERENTIAL SETTING *HdF*  
 ▼  
 LOW LIMIT SETTING *LL*  
 ▼  
 LOW DIFFERENTIAL SETTING *LdF*

The display will return to boiler temperature (default) if Test/Settings Button is not pressed for 5 seconds.

## TROUBLESHOOTING

<b>Burner Will Not Fire</b>	See Flow Chart 1, page 9
<b>Burner Will Not Shut Down</b>	See Flow Chart 2, page 10
<b>Temperature Display Exceeds High Limit Setting</b>	Under normal operation, boiler temperature will continue to rise after the control shuts off the burner. This condition, known as “thermal stacking”, results from hot boiler surfaces continuing to release heat into the boiler water.
<b>No or Insufficient Domestic Hot Water</b>	If the boiler has a tankless coil make sure the low limit setting on the HydroStat is set properly. <b>NOTE:</b> If the low limit setting is dialed fully counter clockwise, it will shut off the low temperature maintenance feature and will function as a cold start control. Faster hot water response may also be achieved by turning off the Thermal Pre-Purge Feature (see page 4). If boiler is operating in conjunction with an indirect water heater, check to be sure the temperature control on the indirect tank is set properly. Make sure any valves in between domestic hot water heating device, boiler, and hot water taps are open.
<b>Boiler Will Not Maintain Low Limit Temperature</b>	Check for overlapping high temperature setting. If the high limit setting is set below the low limit setting, the control will default to the high limit setting and the corresponding high limit differential setting.
<b>Temperature Display Differs from Boiler T&amp;P Gauge Temperature Reading</b>	Temperature variances can result from differing water temperatures within the boiler or different reaction times of the two devices. If the HydroStat temperature is significantly below the T&P gauge temperature, make sure the thermistor is inserted all the way to the end of the well.
<b>LWCO “Active” Light (Green LED) Is Not On</b>	The HydroStat will only provide low water cut-off functionality when used in conjunction with an insulated Electro-Well™. When attached to a standard immersion well, the LWCO “Active” light will remain off and the HydroStat will provide temperature functionality only.
<b>Low Water Light (Red LED) Is On or Blinking</b>	 <b>WARNING:</b> A low water condition is a serious and potentially dangerous condition. Do not attempt to add water to a hot boiler. Allow the boiler to fully cool before adding water. <p>The LOW WATER light indicates that the control is not detecting water in the boiler. If the light is blinking, the control has been programmed to provide lock-out protection in the event of a low water condition (see Manual Reset Low Water Cut-Off on page 5). Pressing the TEST/SETTINGS button will reset the control.</p> <ol style="list-style-type: none"> <li>1. If the light is on and the heating system is filled with water, pull the sensor out of the well and inspect it. Make sure that the metal clip on the sensor is intact. This metal clip must be in contact with the inside of the copper well in order for the control to sense the presence of water. Check that the well does not have excessive build-up of heat transfer grease that may interfere with clip contacting the well.</li> <li>2. Remove well and examine for excessive residue build-up. Clean and re-install.</li> </ol>



# Troubleshooting Flow Chart 1 – Burner Will Not Fire

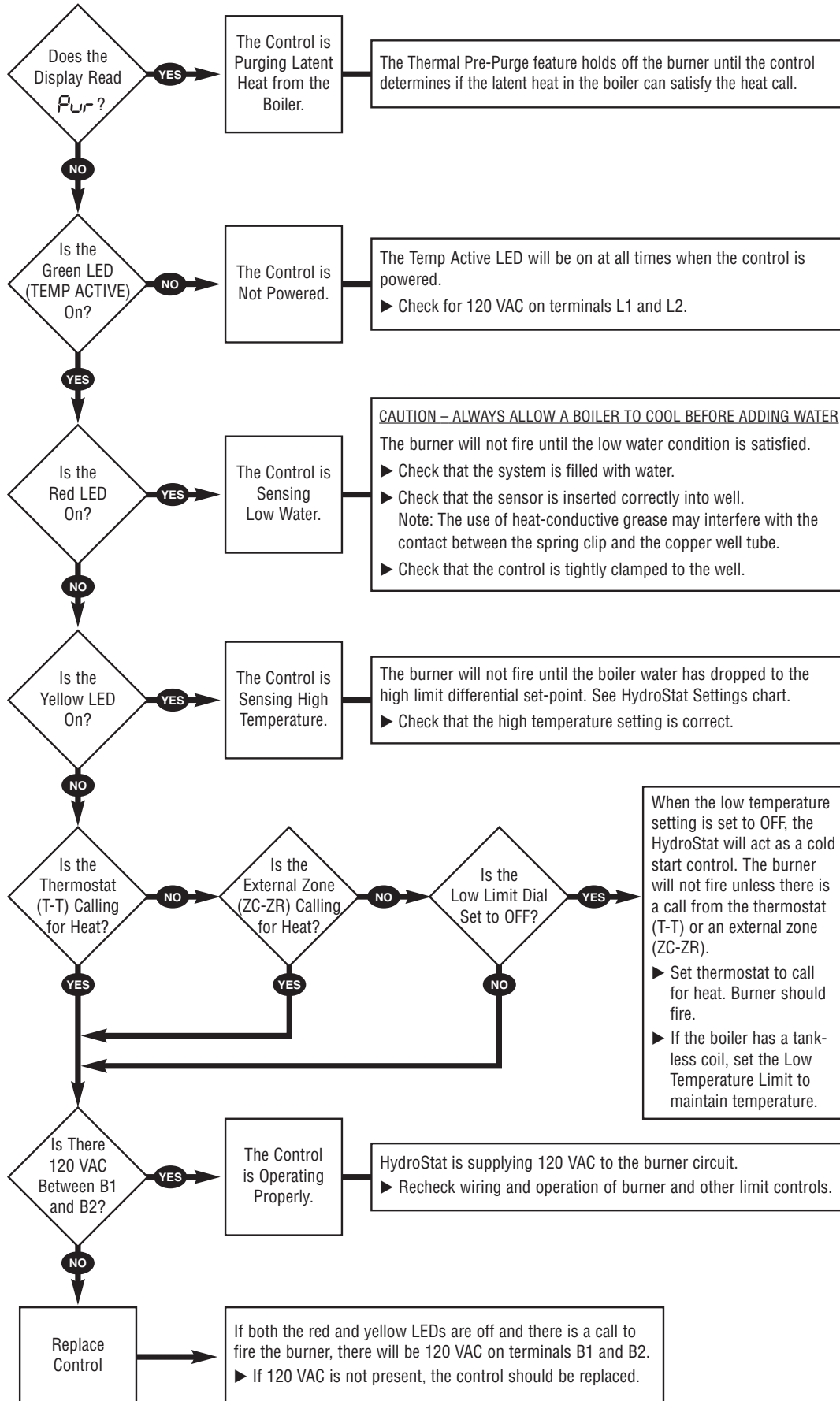

## Troubleshooting Flow Chart 2 – Burner Will Not Shut Down

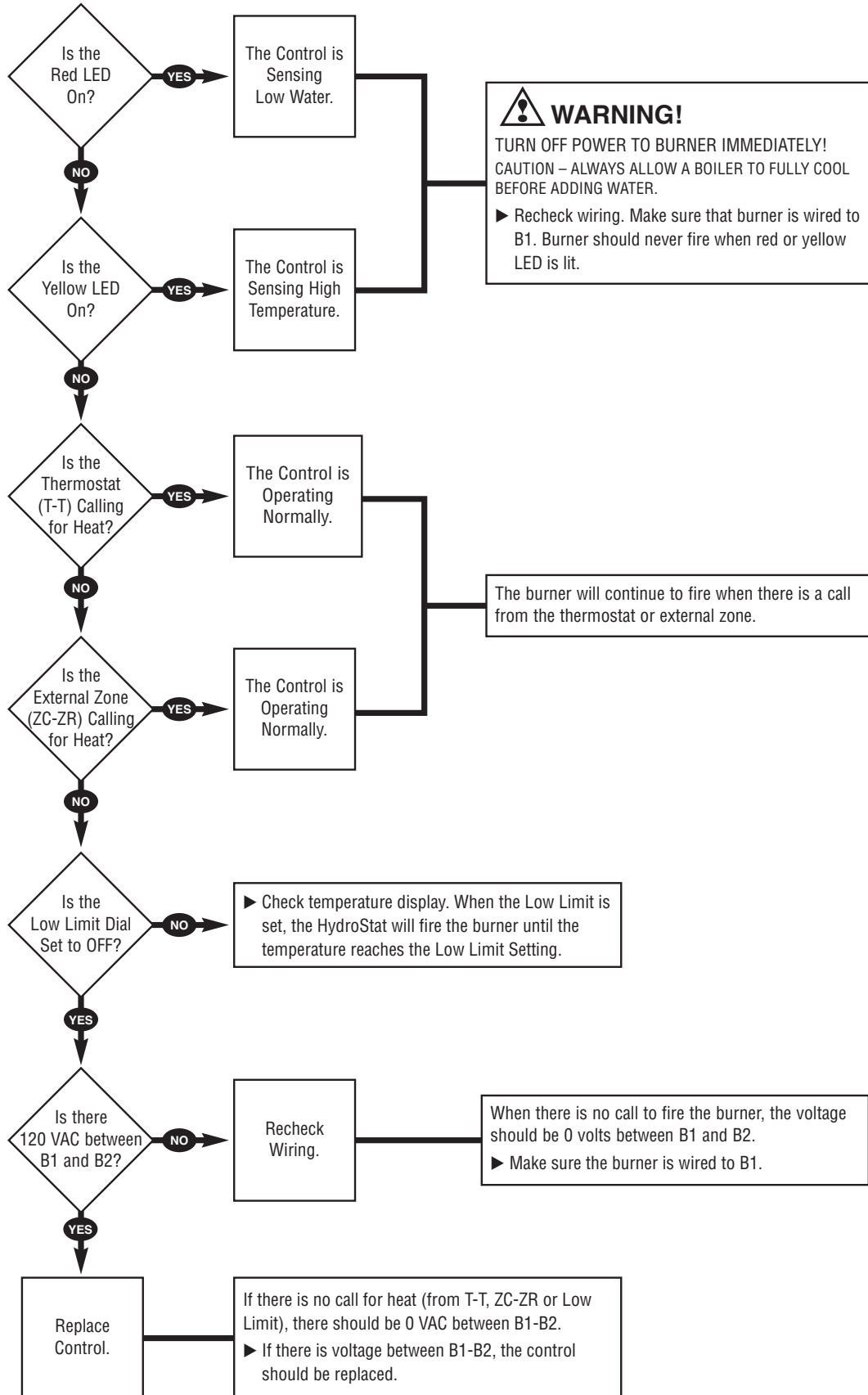

# ELECTRO-WELLS

## HydroStat installed with Electro-Well™

When installed with the Hydrolevel Electro-Well, HydroStat will provide *both* temperature and low water cut-off functionality. If the control was supplied by the boiler manufacturer, it was installed with an Electro-Well. The Electro-Well is available separately for field installations.

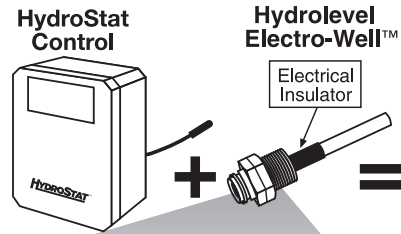

**PROVIDES TEMPERATURE, ECONOMY AND LOW WATER CUT-OFF FUNCTIONALITY**

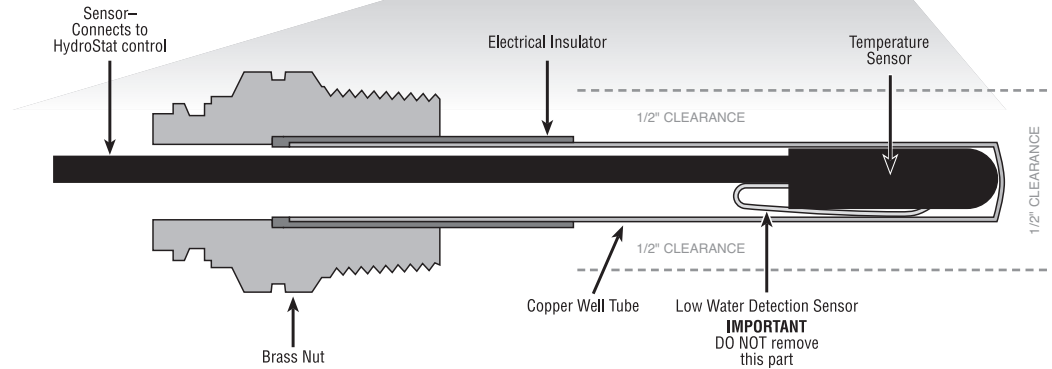

**IMPORTANT:** For proper operation of the low water cut-off function, there must be a minimum of 1/2" clearance between the copper well tube and any surface within the boiler.

**IMPORTANT**  
DO NOT remove this part

## Electro-Well™ Models

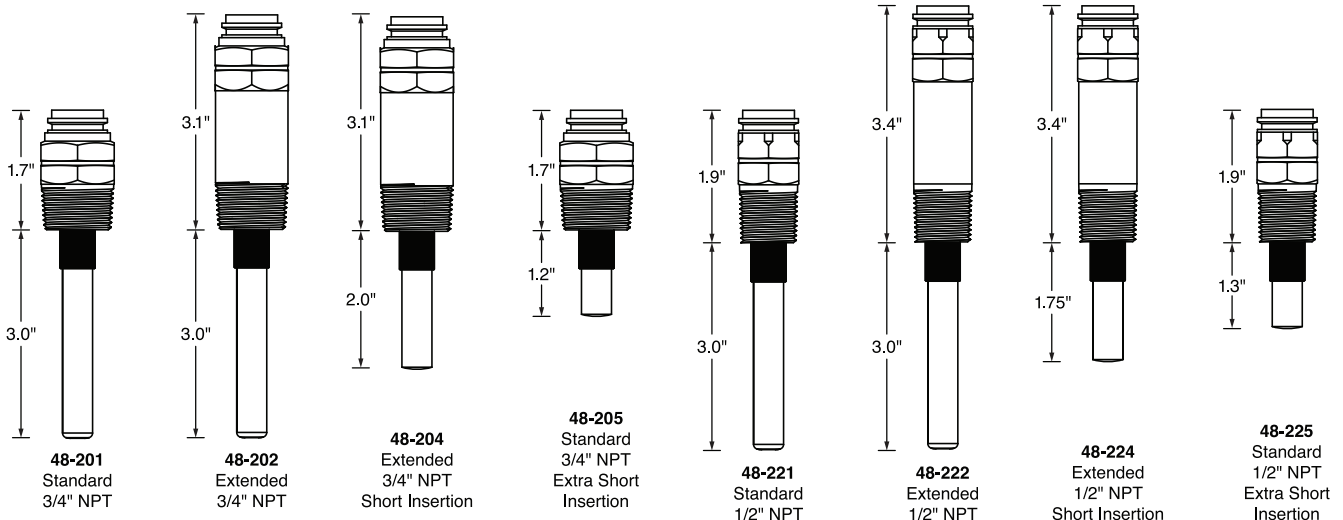

## MAINTENANCE

Remove the Electro-Well from the heating system every five years and clean any scale or sediment deposits from all parts that are exposed to the boiler water. After cleaning, reinstall the well using pipe sealing compound. **Teflon tape is not recommended.**

## REMOTE MOUNTING KITS

Part No.	Description	Part No.	Description
<b>48-101</b>	HydroStat Remote Mount Kit with 24" sensor	<b>48-103</b>	HydroStat Remote Mount Kit with 10' sensor
<b>48-102</b>	HydroStat Remote Mount Kit with 48" sensor	<b>48-104</b>	HydroStat Remote Mount Kit with 20' sensor
		<b>48-121</b>	HydroStat Pipe Mounting Kit with 48" sensor

## DIMENSIONS

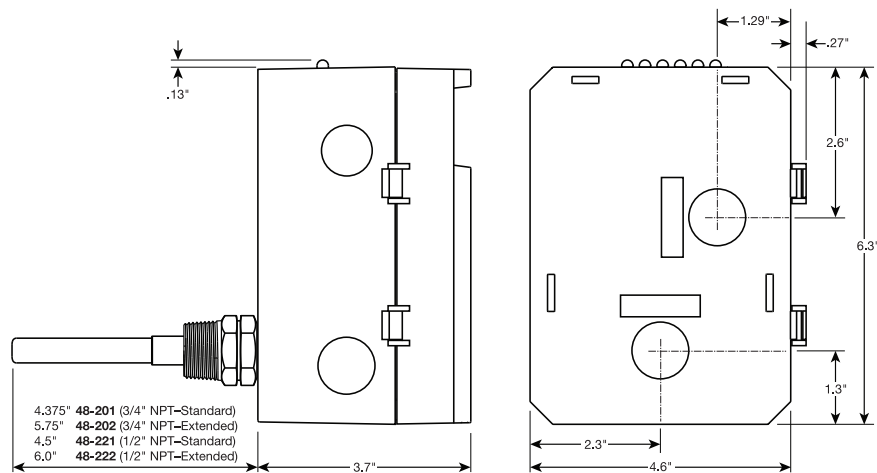

## SPECIFICATIONS HYDROSTAT MODEL 3150

Input voltage	120 VAC, 60 HZ
Burner contacts	7.4 FLA, 44.4 LRA@120 VAC
Circulator contacts	5.8 FLA, 34.8 LRA@120 VAC
Operating range – low limit	Off or 110°F (43°C) - 200°F (93°C)
Operating range – high limit	100°F (38°C) - 220°F (104°C)
Operating range – differential	10°F (6°C) - 30°F (17°C)
Thermostat heat anticipator setting	0.2A



### LIMITED MANUFACTURER'S WARRANTY

We warrant products manufactured by Hydrolevel Company to be free from defects in material and workmanship for a period of two years from the date of manufacture or one year from the date of installation, whichever occurs first. In the event of any claim under this warranty or otherwise with respect to our products which is made within such period, we will, at our option, repair or replace such products or refund the purchase price paid to us by you for such products. In no event shall Hydrolevel Company

be liable for any other loss or damage, whether direct, indirect, incidental or consequential. This warranty is your EXCLUSIVE remedy and shall be IN PLACE OF any other warranty or guarantee, express or implied, including, without limitation, any warranty of MERCHANTABILITY or fitness for a particular purpose. This warranty may not be assigned or transferred and any unauthorized transfer or assignment thereof shall be void and of no force or effect.