



CAUTION!

Before putting the boiler into operation read this manual carefully.

DANGER!

Improper installation, adjustment, alteration, service or maintenance can cause injury, loss of life or property damage. Refer to this manual. For assistance or additional information consult a qualified installer, service agency or the gas supplier.

CAUTION!

The operating manual is part of the documentation that is delivered to the installation's operator. Go through the information in this manual with the owner/operator and make sure that he or she is familiar with all the necessary operating instructions.

NOTICE!

In the Commonwealth of Massachusetts this boiler must be installed by a licensed Plumber or Gas Fitter.

Danger: If the information in these instructions is not followed exactly, a fire or explosion may result causing property damage, personal injury or loss of life.

- Do not store or use gasoline or other flammable vapors and liquids in the vicinity of this or any other appliance.
- What to do if you smell gas
 - Do not try to light any boiler.
 - Do not touch any electrical switch; do not use any phone in your building.
 - Immediately call your gas supplier from a neighbor's phone. Follow the gas supplier's instructions.
 - If you cannot reach your gas supplier, call the fire department.
- Installation and service must be performed by a qualified installer, service agency or the gas supplier.

Notice!

- This manual is available in the English and French language.
- This manual must be retained for future reference.



Installation instructions

Logamax plus

GB162-80 kW
GB162-100 kW

7746800103 (2014/10) US

Read carefully before carrying out installation and maintenance.

Buderus

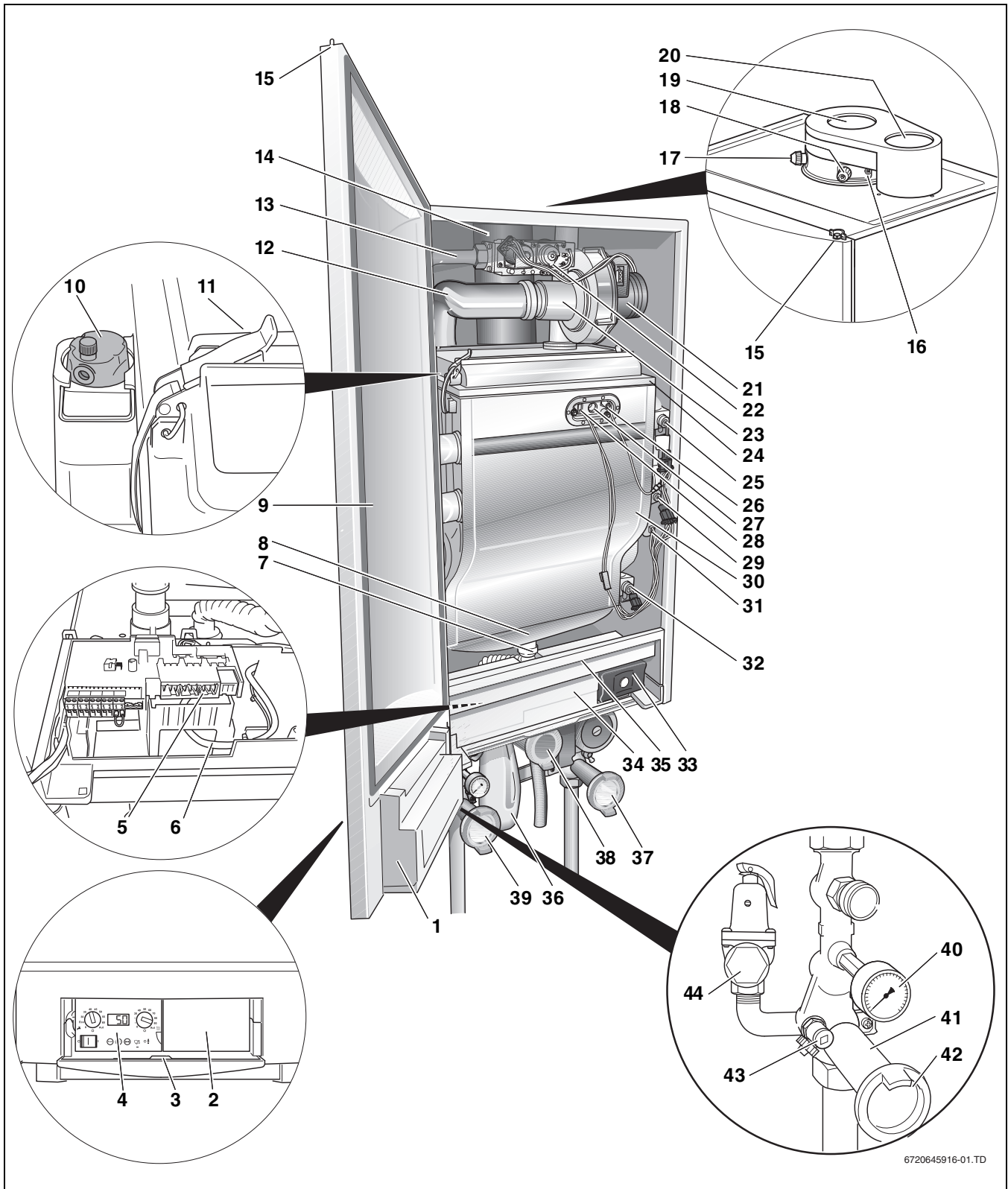

6720645916-01.TD

Fig. 1 Logamax plus GB162 with pump group

- [1] BC10 basic controller receptacle
- [2] Installation option for room controller, e.g. RC35
- [3] Cover with user manual compartment
- [4] BC10 basic controller, can be expanded e.g. by the RC35 room controller
- [5] Connection box (low-voltage and 120 VAC connections)
- [6] Fan harness and mains lead of the pump
- [7] Condensate drain outlet
- [8] Condensate collector
- [9] Boiler front door
- [10] Automatic air vent
- [11] Retaining clips
- [12] Air intake for the fan
- [13] Gas pipe
- [14] Flue gas pipe
- [15] Door lock
- [16] Flue gas sensor
- [17] Flue measuring point
- [18] Measuring point for air intake
- [19] Flue gas connection
- [20] Air intake connection
- [21] Fan
- [22] Gas valve
- [23] Venturi
- [24] Burner cover
- [25] Flow temperature sensor
- [26] Ionization electrode
- [27] Sighting glass
- [28] Glow igniter
- [29] Safety temperature sensor
- [30] Heat exchanger
- [31] Pressure sensor
- [32] Return temperature sensor
- [33] Universal Burner Automatic Version 3 (UBA 3)
- [34] Draw with function module integration options
- [35] Cover shield
- [36] Condensate trap

Pump group (scope of delivery)

- [37] Isolating valve, blue (CH boiler return) with pump, drain cock, check valve and thermometer
- [38] Manual gas shut off valve, yellow (GAS)
- [39] Isolating valve, red (CH boiler flow) with drain cock, pressure gauge and thermometer
- [40] Pressure gauge
- [41] Isolating valve
- [42] Thermometer (optional accessory)
- [43] Drain valve
- [44] Safety valve 30 psi (2 bar) (or 50 psi [3.45 bar] = optional)

The pump group also includes an insulation cover (see also pump group installation instructions).

Low loss header (single appliance only):

- [45] Low loss header (not illustrated)

Contents

1 Explanation of symbols and safety information 5

1.1 Guideline to symbols 5

1.2 Safety instructions 5

2 Regulations and guidelines 6

2.1 Massachusetts Installations Only 6

3 General information 7

3.1 Designated use 7

3.2 Heating system water quality 7

3.3 Pump test 8

3.4 Freeze protection 8

3.5 Tools, materials and further equipment 8

3.6 Disposal 8

4 Dimensions and connections 9

4.1 Without pump group 9

4.2 With pump group 10

5 Packaging and transportation 11

5.1 Scope of delivery 11

5.2 Transporting the boiler 11

6 Installation 12

6.1 Requirements for the installation room 12

6.2 Requirements for the heating system 12

6.3 Installing the boiler 12

6.4 Water and Gas connection 13

6.4.1 General 13

6.4.2 Connecting the pressure relief valve (PRV) 14

6.4.3 Making the gas connection 14

6.4.4 Installing the heating supply and return pipe 14

6.4.5 Installing the pump 15

6.4.6 Installing the condensate trap 15

6.5 Connecting the condensate drain pipe 16

6.5.1 Connecting the expansion vessel in a single-boiler system 16

6.6 Combustion Air and Ventilation Openings 16

6.7 Flue gas adapter 17

6.8 Installation of the Exhaust and Air Intake system 18

6.9 Multiple boiler vent terminal clearance 23

7 Electrical connections 24

7.1 External connection board connections 24

7.1.1 Routing the cable through the boiler 24

7.1.2 Low voltage connections 25

7.1.3 120 VAC connections 25

7.1.4 Controller 26

7.2 Installing function modules (accessories) 26

7.2.1 Installing function modules in the boiler 26

7.2.2 Installing function modules outside the boiler 28

7.3 Electrical wiring diagram 29

8 Operation 30

8.1 BC10 basic controller 30

8.2 BC10 operating instructions 31

9 Start-up procedure 33

9.1 Check for gas leaks 34

9.2 Fill the heating system 34

9.3 Fill the condensate trap with water 35

9.4 Bleed the gas supply valve 35

9.5 Check the air/flue gas connection 36

9.6 Checking the appliance configuration 36

9.7 Measure the gas inlet pressure (working pressure) ... 36

9.8 Check and adjust the gas/air ratio 38

9.9 Carry out a leakage test in operating conditions 39

9.10 Check and adjust the flue gases CO emissions 39

9.11 Function test 39

9.12 Measure the ionization current 40

9.13 Test the Ignition Safety shut off device 40

9.14 Boiler settings 41

9.14.1 Set the heating capacity 41

9.14.2 Set the space heating water temperature 41

9.14.3 Set the pump run-over time 41

9.14.4 Switch DHW mode ON/OFF 41

9.14.5 Set the DHW temperature 41

9.15 Final activities 42

9.15.1 Close the boiler door and the control panel 42

9.15.2 Hand over 42

10 Shutting down the system 42

10.1 Shut down the appliance using the basic controller .. 42

10.2 Shutting down the heating system if there is a risk of freezing (interruption of use) 42

10.3 Shutting down the heating system in the event of an emergency 42

11 Inspection 43

11.1 Prepare the appliance for inspection 43

11.2 Carry out a visual check for general signs of corrosion 43

11.3 Gas valve leakage test 43

11.4 Measure the ionization current 44

11.5 Measure the gas inlet pressure (working pressure) ... 44

11.6 Check and adjust the gas/air ratio 44

11.7 Carry out a leakage test in operating conditions 44

11.8 Measure the flue gases CO emissions 44

11.9 Fill the heating system 44

11.10 Check the air/flue gas connection 44

12	Maintenance	44
12.1	Prepare the heating system for maintenance	44
12.2	Remove the boiler door	44
12.3	Clean the heat exchanger, burner and condensate trap	45
12.3.1	Remove the gas valve	45
12.3.2	Remove the burner cover with the fan and the gas valve	45
12.3.3	Remove the burner and the burner seal	46
12.3.4	Checking ignition unit	46
12.3.5	Disconnect the condensate trap	46
12.3.6	Remove the condensate collector	47
12.3.7	Clean the heat exchanger	48
12.4	Check and adjust the gas/air ratio (flue gases CO ₂ emissions)	48
12.5	Function check	48
13	Display information	49
13.1	Removing the control panel	49
13.2	Replacing the control panel	49
13.3	BC10 Display readings	49
13.4	BC10 Display settings	49
13.5	BC10 Display codes	50
14	Technical specifications	55
14.1	Technical specifications of GB162-boilers at sea level (0-4,000 ft.)	55
15	Reports	57
15.1	Start-up report	57
15.2	Inspection report	58
15.3	Service report	58
16	Spare parts	59
	Index	63

1 Explanation of symbols and safety information

1.1 Guideline to symbols

Warnings



Warnings are indicated in the text by a warning triangle and a gray background.



In case of danger from electric shock, the exclamation point on the warning triangle is replaced with a flash.

Signal words at the beginning of a warning are used to indicate the type and seriousness of the ensuing risk if measures for minimizing damage are not taken.

- **NOTE** indicates that damage to property may occur.
- **CAUTION** indicates possible minor to medium personal injury.
- **WARNING** indicates possible severe personal injury.
- **DANGER** indicates a potential for loss of life.

Important Information



Important information neither indicating personal injury nor damage to property are marked with this symbol. They are separated by lines above and below the text.

Additional symbols

Symbol	Explanation
▶	Sequence of steps
→	Cross-reference to other points in this document or to other documents
•	Listing/list entry
–	Listing/list entry (2nd level)

Table 1

1.2 Safety instructions

Installation and service must be performed by a qualified installer, service agency or the gas supplier.



WARNING:

A fire or explosion may result causing property damage, personal injury or death.

- ▶ If the information in these instructions is not followed exactly,



DANGER:

if flammable gas explodes.

- ▶ Beware if you smell gas: there may be an explosion hazard!

- ▶ Do not store or use gasoline or other flammable vapors and liquids in the vicinity of this or any other boiler.

**WARNING:**

Dangerous flue gas can escape if the air supply is insufficient.

- ▶ Make sure that air vents are not reduced in size or obstructed.
- ▶ The boiler may only be operated after the defect has been remedied.
- ▶ Warn the user of the system of the defect verbally and in writing.

**WARNING:**

Danger of fatal accident from explosive fumes.

- ▶ Only carry out work on gas pipes and fittings if you are properly registered.

General warnings**The following instructions must be observed**

- The boiler must only be used for its designated purpose, observing the Installation Instructions.
- Only use the boiler in the combinations and with the accessories and spares listed.
- Maintenance and repairs must only be carried out by trained professionals.
- You are only permitted to operate the condensing gas boiler with the combustion air/flue gas system that has been specifically designed and approved for this type of boiler.
- Please note that local approval of the flue system and the condensate connection to the public sewer system may be required.
- If boiler installation is provided as replacement heater, **do not** connect new boiler venting to an existing vent system, if it is shared with other appliances.
- The local building regulations stipulating the installation rules at the time of installation.
- The local building regulations concerning the air intake and outlet systems and the chimney connection.
- The regulations for the power supply connection.
- The technical rules laid down by the gas utility company concerning the connection of the gas burner fitting to the local gas main.
- The instructions and standards concerning the safety equipment for the water/space heating system.
- The Installation Instructions for building heating systems.
- The boiler must be located in an area where leakage of the tank or connections will not result in damage to the area adjacent to the boiler or to lower floors of the structure. When such locations cannot be avoided, it is recommended that a suitable drain pan, adequately drained, be installed under the boiler. The pan must not restrict combustion air flow.
- The boiler must be installed such that the gas ignition system components are protected from water (dripping, spraying, rain etc.) during boiler operation and service.
- Do not restrict or seal any air intake or outlet openings.
- If you find any defects, you must inform the owner of the system of the defect and the associated hazard in writing.
- The boiler must not be installed on carpeting.

What to do if you smell gas:

- Do not try to light any boiler.
- Do not touch any electrical switch; do not use any phone in your building.
- Immediately call your gas supplier from a neighbor's phone. Follow the gas supplier's instructions.
- If you cannot reach your gas supplier, call the fire department.

2 Regulations and guidelines

- The installation must conform to the requirements of the authority having jurisdiction or, in the absence of such requirements, to the National Fuel Gas Code, ANSI Z223.1/NFPA 54 and/or CAN/CSA B149.1, Natural Gas and Propane Installation Code.
- Where required by the authority having jurisdiction, the installation must conform to the Standard for Controls and Safety Devices for Automatically Fired Boilers, ANSI/ASME CSD-1.
 - ▶ Install CO detectors per local regulations. Boiler requires yearly maintenance → chap. 12 "Maintenance", page 44.

Operating Limits of the boiler:

Max. boiler temperature:	230 °F (110 °C)
Max. operating pressure:	30 psi (2.6 bar)
- with optional pressure relief valve	50 psi (3.45 bar).

The hot water distribution system must comply with applicable codes and regulations. When replacing an existing boiler, it is important to check the condition of the entire hot water distribution system to ensure safe operation.

2.1 Massachusetts Installations Only

(a) For all side wall side horizontally vented gas fuelled equipment installed in every dwelling, building or structure used in whole or in part for residential purposes, including those owned or operated by the Commonwealth and where the side wall exhaust vent termination is less than 7 feet above finished grade in the area of the venting, including but not limited to decks and porches, the following requirements shall be satisfied:

1. INSTALLATION OF CARBON MONOXIDE DETECTORS. At the time of installation of the side wall horizontal vented gas fueled equipment, the installing plumber or gas fitter shall observe that a hard wired carbon monoxide detector with an alarm and battery back-up is installed on the floor level where the gas equipment is to be installed. In addition, the installing plumber or gas fitter shall observe that a battery operated or hard wired carbon monoxide detector with an alarm is installed on each additional level of the dwelling, building or structure served by the side wall horizontal vented gas fueled equipment. It shall be the responsibility of the property owner to secure the services of qualified licensed professionals for the installation of hard wired carbon monoxide detectors
 - In the event that the side wall horizontally vented gas fueled equipment is installed in a crawl space or an attic, the hard wired carbon monoxide detector with alarm and battery back-up may be installed on the next adjacent floor level.
 - In the event that the requirements of this subdivision can not be met at the time of completion of installation, the owner shall have a period of thirty (30) days to comply with the above requirements; provided, however, that during said 30 day period, a battery operated carbon monoxide detector with an alarm shall be installed. alarm and battery back-up may be installed on the next adjacent floor level.

2. APPROVED CARBON MONOXIDE DETECTORS. Each carbon monoxide detector as required in accordance with the above provisions shall comply with NPA 720 and be ANSI/UL 2034 listed and IAS certified.
3. SIGNAGE. A metal or plastic identification plate shall be permanently mounted to the exterior of the building at a minimum height of 8 ft. above grade directly in line with the exhaust vent terminal for the horizontally vented gas fueled heating appliance or equipment. The sign shall read, in print size no less than 1-½" in size, GAS VENT DIRECTLY BELOW. "KEEP CLEAR OF ALL OBSTRUCTIONS".
4. INSPECTION. The state or local gas inspector of the side wall horizontally vented gas fueled equipment shall not approve the installation unless, upon inspections, the inspector observes carbon monoxide detectors and signage installed in accordance with the provisions of 248 CRM 5.08(2)(a) 1 through 4.

(b) EXEMPTIONS: The following equipment is exempt from 248 CRM 5.08(2)(a) 1 through 4:

The following equipment is exempt from 248 CRM 5.08(2)(a) 1 through 4:

1. The equipment listed in Chapter 10 entitled "Equipment Not Required To Be Vented" in the most correct edition of NFPA 54 as adopted by the board: and
2. Product Approved side wall horizontally vented gas fueled equipment installed in a room or structure separate from the dwelling, building or structure used in whole or in part for residential purposes.

(c) MANUFACTURERS REQUIREMENTS - GAS EQUIPMENT VENTING SYSTEM REQUIRED.

When the manufacturer of Product Approved side wall horizontally mounted gas equipment provides a venting system design or venting system components with the equipment, the instructions provided by the manufacturer for the installation of the equipment and venting shall include:

1. Detailed instructions for the installation of the venting system or the venting system components: and
2. A complete parts list for the venting system design or venting system.

(d) MANUFACTURERS REQUIREMENTS - GAS EQUIPMENT VENTING SYSTEM NOT PROVIDED.

When the manufacturer of Product Approved side wall horizontally vented gas fueled equipment does not provide the parts for the venting of flue gases, but identifies "special venting systems", the following requirements shall be satisfied by the manufacturer:

1. The referenced "special venting systems" shall be included with the appliance or equipment installation instructions: and
2. The "special venting systems" shall be Product Approved by the Board, and the instructions for that system shall include a parts list and detailed installation instructions.

(e) A copy of all instructions.

For all Product Approved side wall horizontally vented gas fueled equipment, all venting instructions, all parts lists for venting instructions, and/or venting design instructions shall remain with the appliance or equipment at the completion of the installation.

3 General information

About these instructions

These Installation Instructions contain important information for the safe and professional installation, start-up and maintenance of the boiler with boiler input rating of 80 kW and 100 kW.

These Installation Instructions are intended for professional installers, who have the necessary training and experience for working on heating and gas systems.

Cascade installation

Special cascade units (accessories) have been developed to enable this boiler to be installed in a cascade system. Every cascade unit includes an installation frame, horizontal headers, connection pipes for the boiler, main gas pipe and a vertical low loss header. Cascade units are available for installing the boilers inline or back-to-back. These cascade units make installing a cascade system easier and less labor intensive.

Please contact Buderus for further information about cascade systems.

Updating of documentation

The following technical documentation is available for the Logamax plus GB162-80 kW/100 kW:

- Installation instructions,
- User's manual,
- Service manual.

Subject to technical modifications

Slight changes may be made without prior notice to the illustrations, process steps and technical data as a result of our policy of continuous improvement

GB162	Natural Gas	Propane Gas
80 kW	290,000 btu/hr	270,000 btu/hr
100 kW	333,000 btu/hr	315,000 btu/hr

Table 2 max. input rate

3.1 Designated use

The boiler was designed to heat water in a central heating system and generating domestic hot water. It is suitable for connection to fully pumped, sealed water systems only, with a maximum supply temperature set point off 180 °F (82 °C).

The boiler can be installed either as a single system or as part of a multiple system (cascade system).

This boiler may not be installed in places, 4,000 ft. above sea level.

3.2 Heating system water quality

The quality of the system water is very important. Poor water quality can damage heating systems due to scale formation and corrosion. For further details, please see the accompanying "Water quality requirements for Logamax plus GB162-80kW/100 kW" manual.

**CAUTION:**

Risk of system damage due to unsuitable heating system water.

- ▶ If oxygen-permeable pipes are used, e.g. for under floor heating systems, the systems must be separated from one another by plate heat exchangers. Unsuitable heating system water promotes sludge and corrosion formation. This can result in heat exchanger malfunction and damage.

3.3 Pump test

If the boiler has not been operational for approx. 2 days, the pump will automatically run for 10 seconds every 24 hours. This pump test is first carried out 24 hours after the main power has been connected to the boiler.

3.4 Freeze protection

The boiler has integrated freeze protection that switches the boiler ON at a space heating (CH) water temperature of 45 °F (7 °C) and switches it OFF at a CH flow temperature of 59 °F (15 °C).

This feature does not protect the central heating system from freezing. If there is a risk of radiators or pipe sections freezing up, we recommend setting the pump run-over time to 24 hours (→ § 13.4. page 49)

3.5 Tools, materials and further equipment

For the installation and maintenance of the boiler you will need the standard tools for space heating, gas and water fitting. In addition, a hand truck with a fastening belt is useful.

3.6 Disposal

- ▶ Dispose of the boiler packaging in an environmentally sound manner.
- ▶ Dispose of components of the heating system (e. g. boiler or control device), that must be replaced in an environmentally responsible manner.

4 Dimensions and connections

4.1 Without pump group

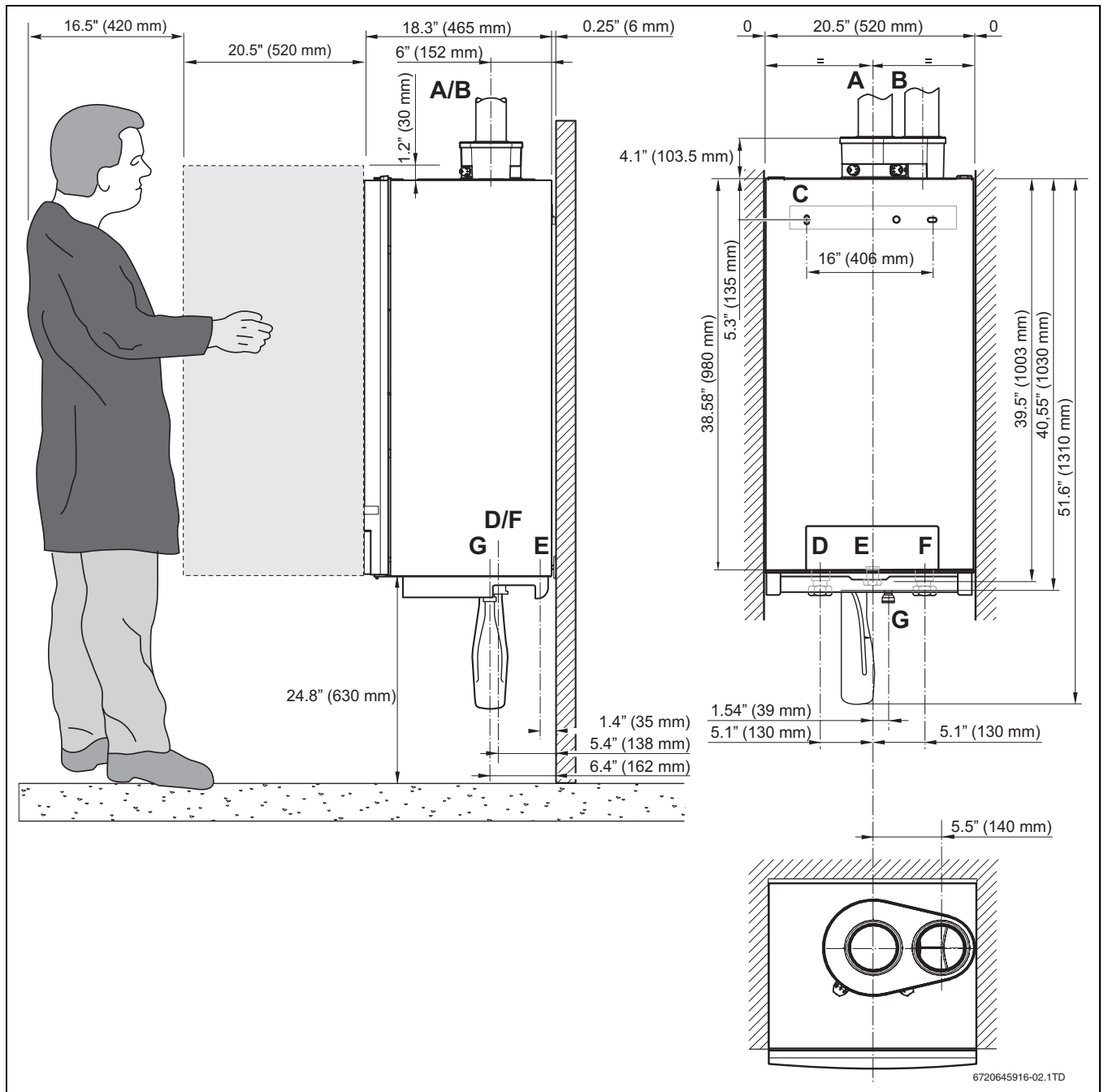

Fig. 2 Dimensions and connections without pump group

- [A] (LA) = Flue gas connection; inside diameter 4" (100 mm)
- [B] (AA) = Air intake connection; inside diameter 4" (100 mm)
- [C] (WB) = Wall Bracket (not shown)
- [D] (VK) = Supply; G1½" union nut with female thread
- [E] (GAS) = Gas connection to boiler; Rp1" female thread
- [F] (RK) = Return; G1½" union nut with female thread
- [G] (AKO) = Condensate outlet; Ø 32 mm (1¼") O/D

The required permanent clearances (closet) are:

- in front: 1" (25 mm)
- right side: 0
- left side: 0
- above: 6" (152 mm).

The position selected for installation MUST allow adequate space for servicing in front of the boiler of at least 16.5" + 20.5" = 37" (940 mm). Maintain an installation clearance from combustible construction from hot water piping of at least 1" (25 mm).

4.2 With pump group

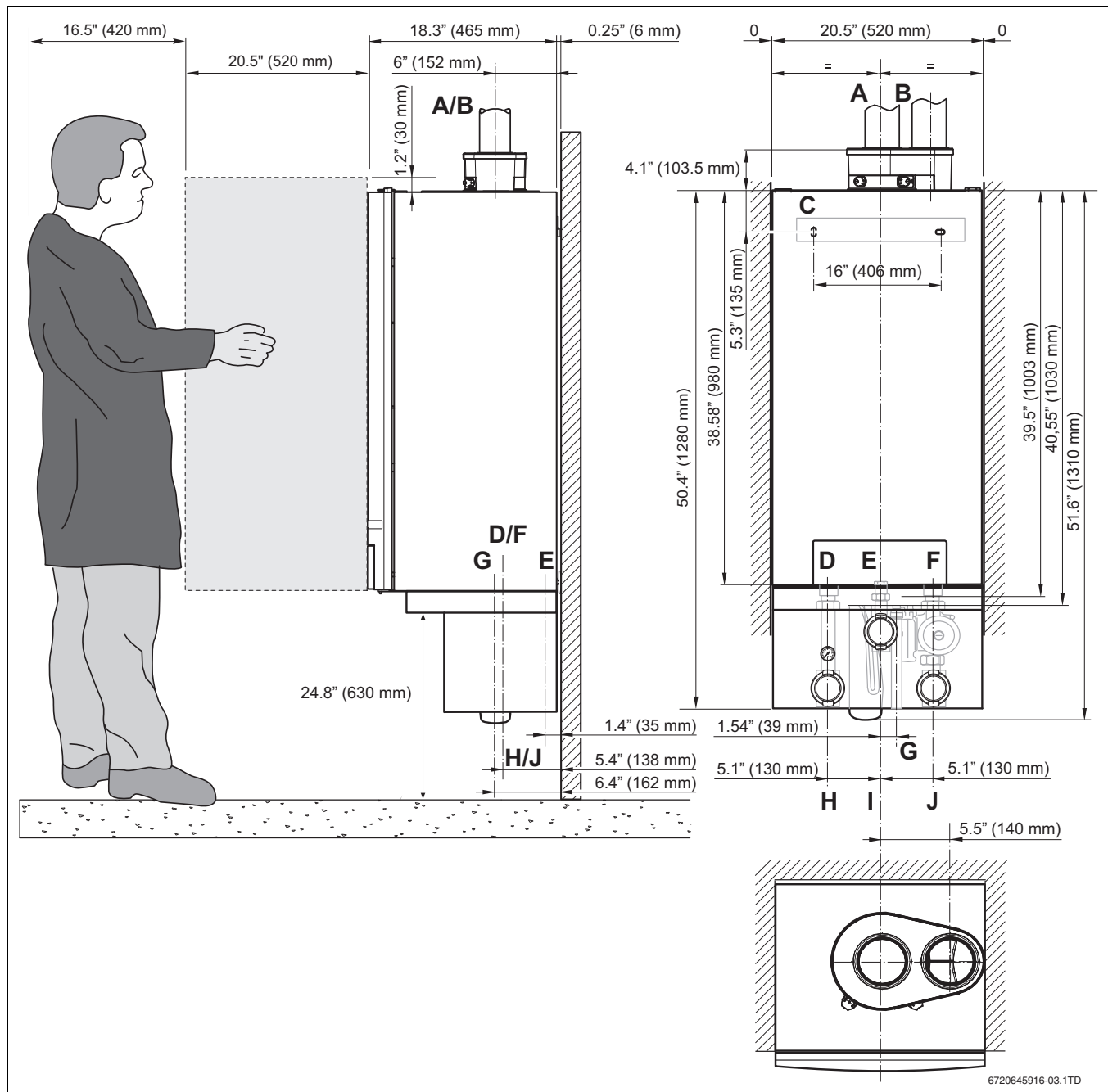

Fig. 3 Dimensions and connections with pump group

- [A] (LA) = Flue gas connection; inside diameter 4" (100 mm)
- [B] (AA) = Air intake with pompador; inside diameter 4" (100 mm)
- [C] (WB) = Wall Bracket (not shown)
- [D] (VK) = Supply; G1½" union nut with female thread
- [E] (GAS) = Gas connection to boiler; Rp1" female thread
- [F] (RK) = Return; G1½" union nut with female thread
- [G] (AKO) = Condensate outlet; Ø 32 mm (1¼") O/D
- [H] (PF) = Pump group supply; G1½" male thread, flat seal
- [I] = Gas connection to pump group; 1" NPT female thread
- [J] (PR) = Pump group return; G1½" male thread, flat seal

The required permanent clearances (closet) are:

- in front: 1" (25 mm)
- right side: 0
- left side: 0
- above: 6" (152 mm).

The position selected for installation MUST allow adequate space for servicing in front of the boiler of at least 16.5" + 20.5" = 37" (940 mm). Maintain an installation clearance from combustible construction from hot water piping of at least 1" (25 mm).

5 Packaging and transportation

5.1 Scope of delivery

The boiler is delivered factory-assembled.

- ▶ When receiving the delivery, check if the packaging is intact.
- ▶ Check that all items are included in the delivery.

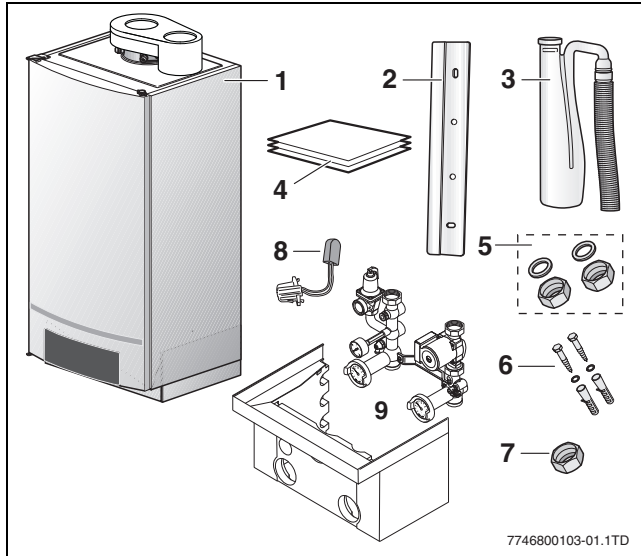

Fig. 4 Items supplied with unit

Nr.	Parts	Qty.	Packaging
1	Boiler with casing	1	1 box
2	Wall bracket	1	
3	Condensate trap with hose	1	
4	Technical documents set	1	
5	Supply and return union nuts with sealing rings	1	
6	Screws and plugs for wall bracket	2	
7	Union nut for gas connection	1	
8	DHW sensor	1	
9	Pump group	1	1 box

Table 3 Items supplied with GB162-80 kW/100 kW

Additional required accessories (not in delivery content)

A single boiler must be installed with the Buderus low loss header (LLH) to regulate the flow. The low loss header must be ordered separately. The low loss header delivery comes also with the AM10 modulating outdoor reset control.

Multiple boiler cascade installations can use the Buderus cascade frame accessories. Please contact Buderus for further informations.

- ▶ When receiving the delivery, check if the packaging is intact.
- ▶ Check that all items are included in the delivery (→ fig. 5).

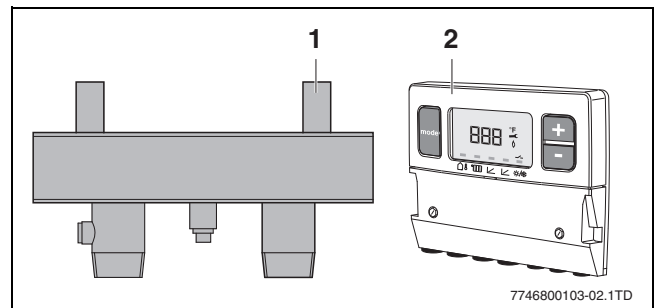

Fig. 5 Additional accessories

- [1] Low loss header (single installation only)
- [2] AM10 modulating outdoor reset control

5.2 Transporting the boiler



CAUTION: The boiler may be damaged when it is improperly secured.

- ▶ Only transport the boiler using the right transportation equipment, such as a hand truck with a fastening belt or special equipment for maneuvering steps.
- ▶ During transportation the boiler must be secured on the transportation equipment to prevent it from falling off.
- ▶ Protect all parts against impacts if they are to be transported.
- ▶ Observe the transportation markings on the packaging.



CAUTION: The unpacked boiler may be damaged when not protected against contamination

- ▶ Leave the protective covers on the connections.
- ▶ Cover the flue gas connections at the top of the boiler with plastic film.

- ▶ Always lift and carry the boiler with 2 people as shown in fig. 6, or use a hand truck or special equipment.

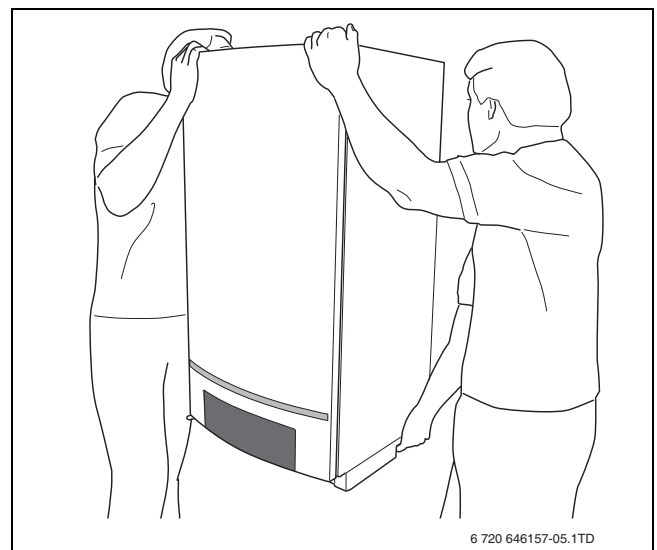

Fig. 6 Lift and carry the boiler correctly



CAUTION: Damage to the unit by lifting or carrying incorrectly.

- ▶ Do not hold the boiler by the door covering the control panel (→ fig. 7).

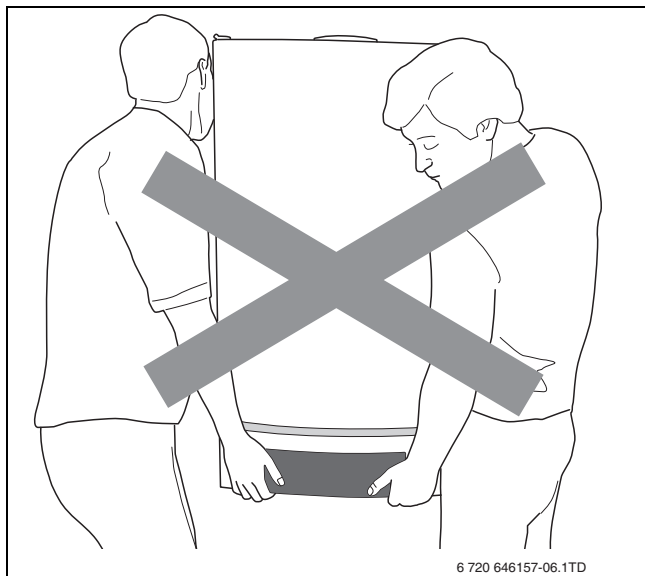

Fig. 7 Incorrect way of lifting and carrying the boiler

6 Installation

6.1 Requirements for the installation room



DANGER:

- ▶ Install the heating system in a frost-free room.
- ▶ If the boiler is operated dependent on room air, the installation room must have the required air vents. Do not obstruct these vents. The air vents must always be free.
- ▶ When installed in a room with thin walls or a thin floor, resonating noise may occur. Install noise reducing parts if required.
- ▶ Do not store any flammable materials or liquids in the immediate vicinity of the boiler.
- ▶ Never use any chlorinated detergents or halogenated hydrocarbons (e. g. in spray cans, solvents and detergents, paints, adhesives).
- ▶ Do not allow too much dust to collect on the boiler.

6.2 Requirements for the heating system

- ▶ Installing a dirt trap like a y-strainer and a desludging device is required. This must be installed in the heating system in the immediate vicinity of the boiler, in an easily accessible position between the boiler and the lowest point in the return of the system.
- ▶ Clean the dirt trap at every annual service.
- ▶ Never use salt bedding type exchangers (ion exchangers) to soften the water.
- ▶ The low loss header and boiler connection set must be installed (supplied with the boiler).

- ▶ When using oxygen-permeable pipes (plastic), e.g. for floor heating systems, you must separate the system using secondary heat exchangers.

6.3 Installing the boiler

Observe the installation distances of the combustion air/flue gas system.

- ▶ Before starting installation check that the carrying capacity of the wall is sufficient for the boiler weight.



NOTICE

- ▶ To protect the connection orifice you must not remove the styrofoam bottom panel.
- ▶ Do not lift the boiler by the door covering the control panel (→ chap. 5.2 "Transporting the boiler", page 11).
- ▶ Protect the boiler and the combustion air/flue gas orifice against pollution during installation.

- ▶ Remove the packaging and dispose of it in an environmentally manner.
- ▶ Measure the installation height (→ chap. 4 "Dimensions and connections", page 9).
- ▶ Mark both holes with the wall bracket (→ fig. 8) using a spirit level.
- ▶ Install the wall bracket with 2 screws (→ fig. 8).

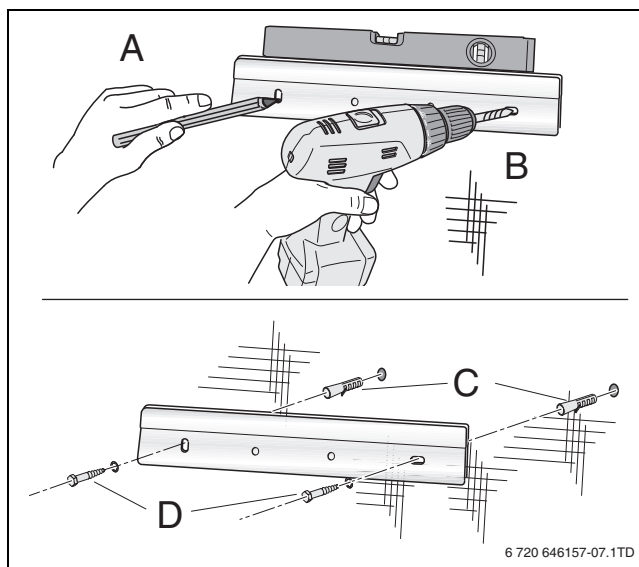

Fig. 8 Installing the wall bracket

- ▶ With 2 people, lift the boiler by holding it by its back and by the transport rail at its bottom and install it on the wall bracket (→ fig. 6, page 11).
- ▶ The boiler can be moved sideways to get the correct position.

- ▶ Level the boiler with the set screw and a spirit level (→ fig. 9).

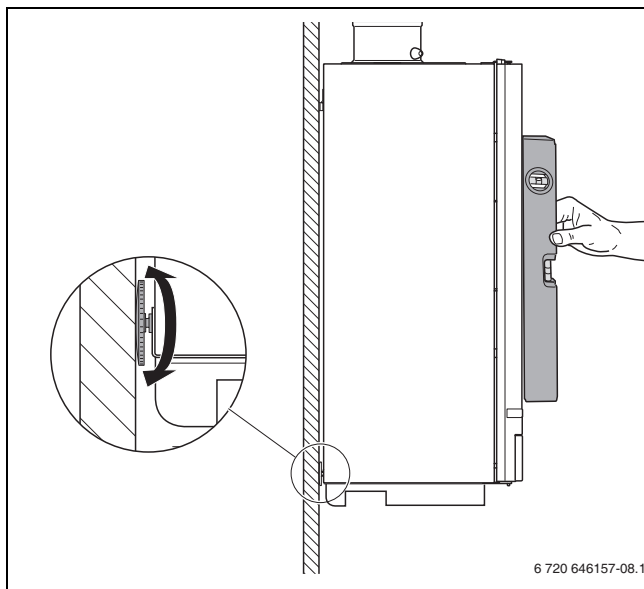

Fig. 9 Aligning the boiler with the set screw

- ▶ Remove the protective covers from the bottom of the boiler (→ fig. 10).

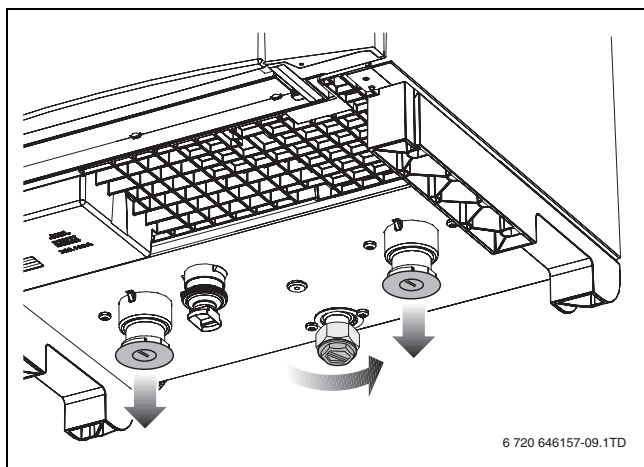

Fig. 10 Removing the covers - boiler bottom



NOTICE

- ▶ Some residual water from final testing may leak away.

6.4 Water and Gas connection

6.4.1 General

The water and gas connections to the boiler are made using the pump group (→ fig. 4, page 11). This pump group includes the circulation pump and a pressure relief valve.

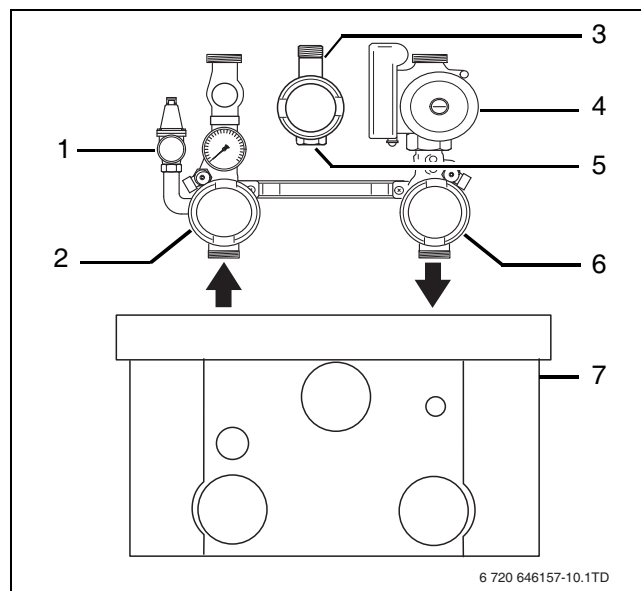

Fig. 11 Pump group

- [1] pressure relief valve
- [2] supply water valve
- [3] manual gas shutoff valve
- [4] circulation pump
- [5] gas inlet
- [6] return water valve
- [7] pump group cover



NOTICE

- ▶ If you do not use the included pump group, you have to install a separate circulation pump under the boiler. This pump must be selected so that the volume flow through the boiler is sufficient to handle the maximum boiler input rating (→ § 6.4.5, page 15).

- ▶ Install the pump group on the boiler in accordance with the pump group installation instructions.

A single boiler must be installed with the low loss header to regulate the flow.

- ▶ Install the low loss header [1].

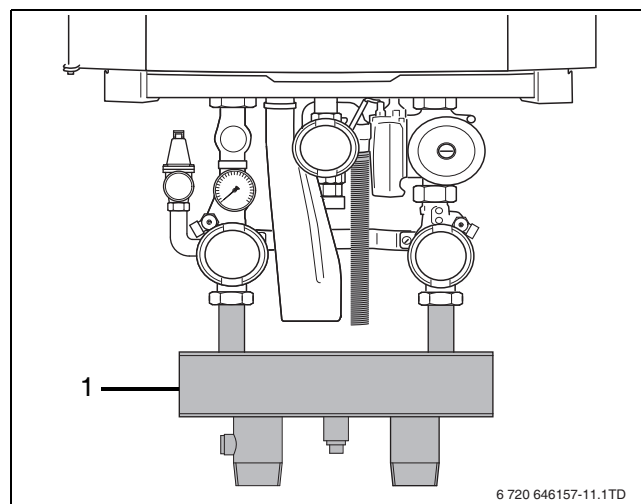

Fig. 12 Low loss header



NOTICE

- ▶ Avoid installing the boiler above radiation levels. If the boiler is installed above radiation sections, a low water cutoff shall be installed and wired to the boiler. Follow local code or in case of use of a low water cutoff, be aware to use an air vent, in order to prevent the boiler from shutting down unnecessarily

6.4.2 Connecting the pressure relief valve (PRV)

The pressure relief valve is a part of the supplied pump group (→ fig. 11, [1]). A listed ASME pressure relief valve supplied with the boiler must be installed at the time of installation. No valve is to be placed between the PRV and the boiler.

No reducing coupling or other restriction may be installed in the discharge line. The discharge line must be within 12" (305 mm) with a minimum of 4" (100 mm) above a drain and installed such that it allows complete drainage of both the PRV and the line. The location of the PRV must be readily accessible for servicing or replacement and be mounted as close to the boiler as possible. To install the PRV, a suitable fitting connected to an extension on a "T" fitting can be sweated to the hot water line. Support all piping.

Maintain an installation clearance from combustible construction of at least 1" (25 mm) from the hot water piping.

6.4.3 Making the gas connection



DANGER:

- ▶ Only carry out work on gas lines if you are a qualified gas fitter

- ▶ The manual gas shutoff valve is part of the pump group, and is installed in accordance with the pump group installation instructions.
- ▶ Determine proper size gas pipe for the installation using table 4 and table 5. Do not forget the pipe fitting losses and observe proper size of the fittings.
- ▶ Connect the gas supply pipe to the manual shutoff valve, so that it is free from any strain.

Length of pipe in feet (m)	Gas volume Capacity in ft. ³ /hr ¹			
	¾"	1"	1¼"	1½"
10 (3.05)	278	520	1,060	1,600
20 (6.1)	190	350	730	1,100
30 (9.15)	152	285	590	890
40 (12.2)	130	245	500	760
50 (15.25)	115	215	440	670
75 (22.88)	93	175	360	545
100 (30.5)	79	160	305	480
150 (47.25)	64	120	250	380

Table 4 Gas pipe capacity for different pipe sizes

1) Maximum pipe capacity in ft.³/hr, based on a specific gravity of 60 (42 mbar) and a inlet gas pressure of 14" W.C. (35 mbar) or less and a pressure drop of 3" W.C. (20 mbar)

Steel pipe diameter in inches (mm)	Equivalent length for Pipe Fittings in feet (m)			
	Type of pipe fitting			
	90°-Elbow	Tee flow thru branch	Gate valve	Gas cocks
¾ (19)	2.1 (0.64)	4.1 (1.25)	0.5 (0.15)	1.25 (0.38)
1 (25)	2.6 (0.79)	5.2 (1.59)	0.6 (0.18)	1.60 (0.49)
1¼ (32)	3.5 (1.07)	6.9 (2.11)	0.8 (0.24)	2.15 (0.66)
1½ (38)	4.0 (1.22)	8.0 (2.44)	0.9 (0.27)	2.50 (0.76)

Table 5 Equivalent length for pipe fittings in feet

6.4.4 Installing the heating supply and return pipe

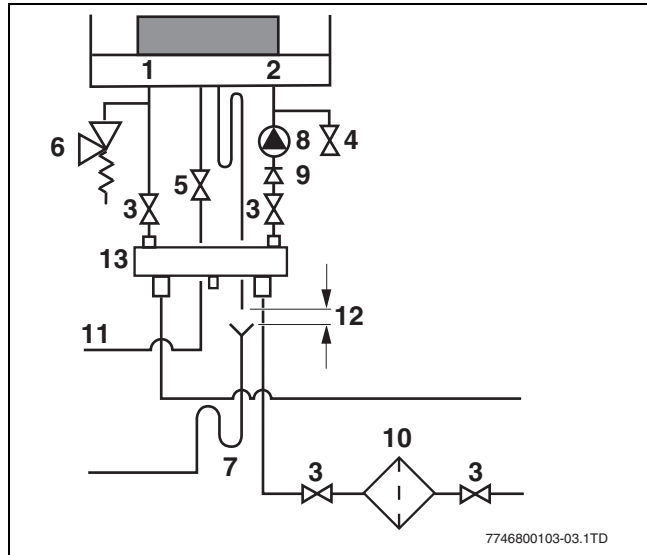

Fig. 13 Connecting the boiler supply and return

- [1] Supply
- [2] Return
- [3] Isolating valves
- [4] Drain cock
- [5] Gas valve
- [6] Pressure relief valve
- [7] Condensate trap
- [8] Pump
- [9] Non-return valve
- [10] Dirt filter (for example scale cartridge or y-strainer)
- [11] Gas supply
- [12] Air gap > 1" (25.4 mm)
- [13] Low loss header (single boiler installation)



NOTICE

- ▶ When using plastic pipes, observe the supplier's instructions - especially those referring to recommended jointing techniques and the notes relating to the heating system water on page 8.

**NOTICE**

- ▶ To prevent contamination in the heating system we recommend you integrate a dirt filter (→ fig. 13, [10]) in the return pipe, near the boiler. In an old system it is a requirement to install a dirt filter. Also install shutoff valves to enable filter cleaning immediately upstream and downstream of the dirt filter (scale cartridge or y-strainer)

- ▶ Connect the supply pipe with a flat rubber seal installed to the Supply connection (→ fig. 13, [1]) making sure it is not under stress. Use a supply pipe with a minimum diameter of 1½" (38 mm).
- ▶ Connect the return pipe with a flat rubber seal installed to the Return connection (→ fig. 13, [2]) making sure it is not under stress. Use a return pipe with a minimum diameter of 1½" (38 mm).

6.4.5 Installing the pump

Always use the supplied Buderus pump group and the low loss header when installing a single boiler so correct flows are guaranteed. It is not necessary to install a low loss header for cascade systems.

- ▶ Install the pump (→ fig. 13, [8]) in the return circuit (→ fig. 13, [2]).

6.4.6 Installing the condensate trap**WARNING:**

Danger of fatal accident due to poisoning

- ▶ If the condensate trap is not filled with water, flue gas can escape and put people's lives at risk.

- ▶ Fill the condensate trap (supplied with the boiler) with water (→ fig. 14).

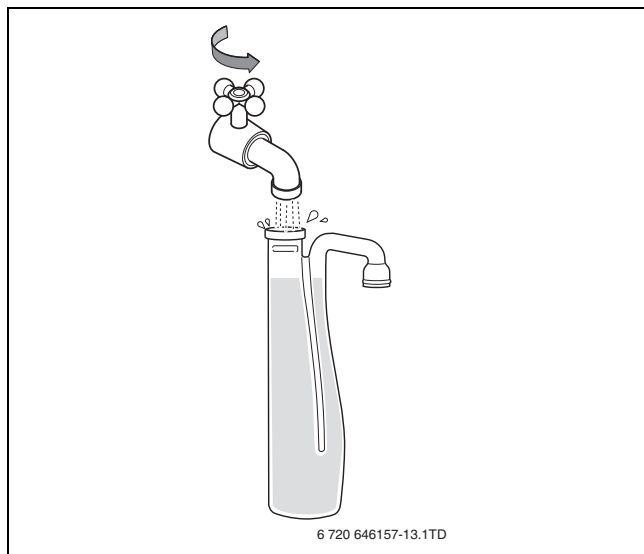

Fig. 14 Filling the condensate trap with water

- ▶ Connect the condensate trap [1] to the condensate outlet. The condensate trap has a bayonet connector, insert and turn ¼ rotation clockwise to click into position.

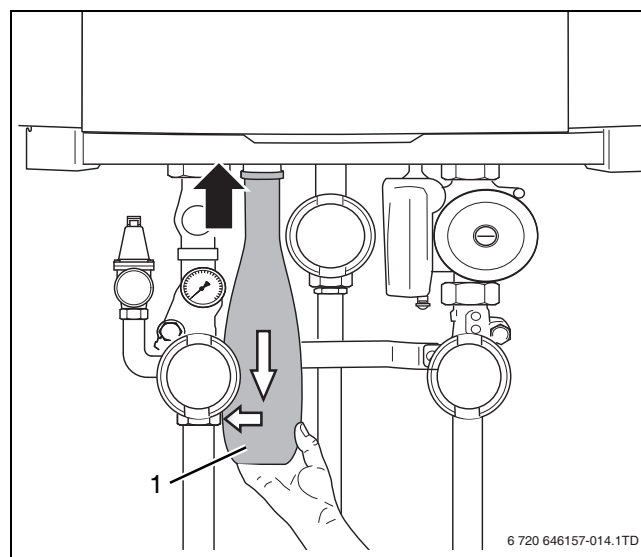

Fig. 15 Installing the condensate trap

- ▶ Connect the condensate trap hose [3] and the rubber sleeve [2] to the condensate trap [1].

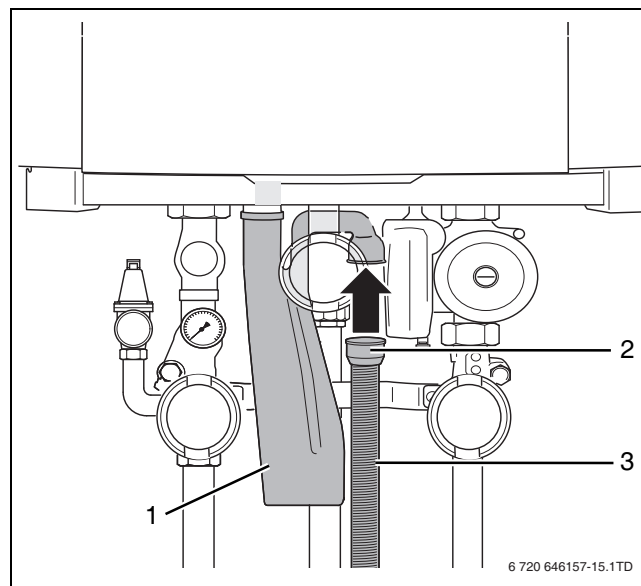

Fig. 16 Installing the condensate trap hose

6.5 Connecting the condensate drain pipe



NOTICE

► The condensate must be drained from the boiler in accordance with local, state or federal rules and regulations.



NOTICE

► Use materials approved by the authority having jurisdiction. In the absence of such authority, PVC and CPVC pipe must comply with ASTM D1785, F441 or D2665. Cement and primer must comply with ASTM D2564 or F493. For Canada, use ULC certified PVC or CPVC pipe, fittings and cement.

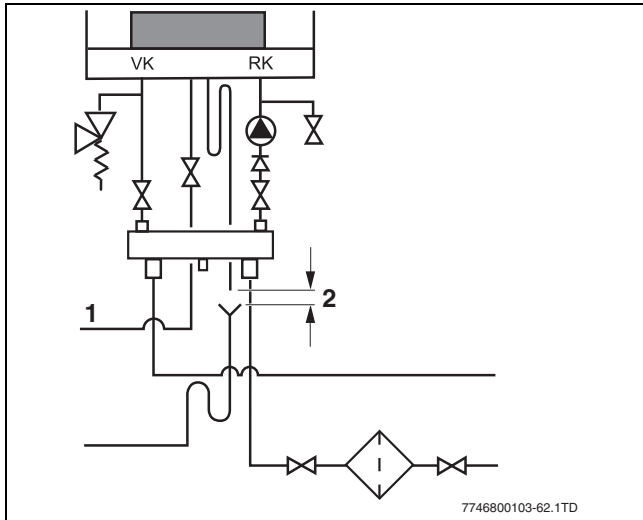

Fig. 17 Connecting the condensate trap

- [1] Condensate trap
- [2] Air gap > 1" (25.4 mm)

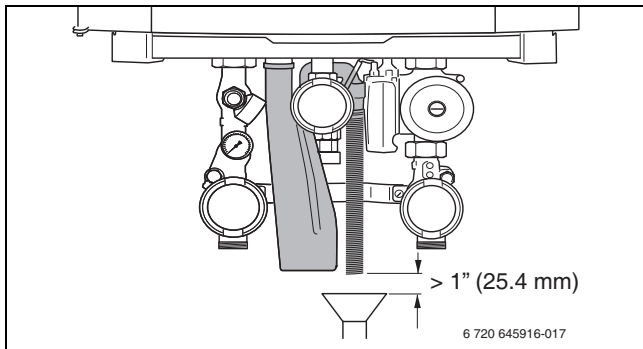

Fig. 18 Condensate drainage pipe

- Install the condensate drain pipe taking the following into account:
 - An air gap of at least 1" (25.4 mm) must be maintained between the boiler condensate trap hose and the condensate pipe work (→ fig. 17 and fig. 18).
 - If the condensate outlet of the boiler is lower than the drain, a condensate pump must be used.
 - The condensate produced by the boiler has a pH value between 3 and 4.
- Install a neutralization unit if required by the local code.

6.5.1 Connecting the expansion vessel in a single-boiler system



CAUTION:

Damage to the installation due to faulty pressure relief valve.

- The expansion vessel must be of sufficient capacity.

- Connect the expansion tank to the boiler return. If a check valve is available: connect the expansion vessel to the CH-side of the check valve in the return circuit [1].

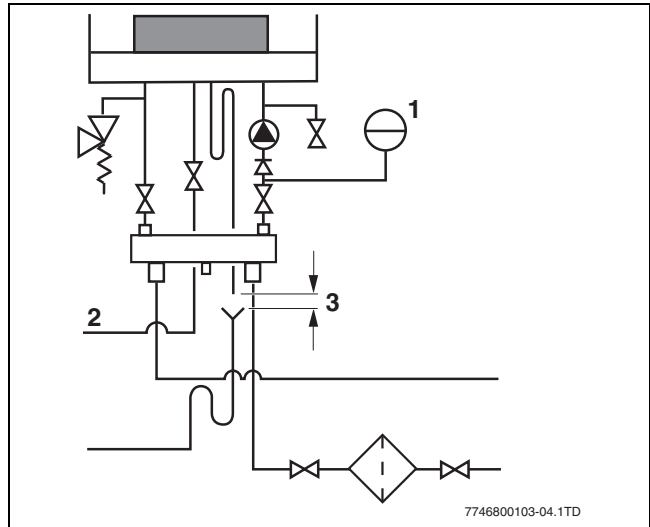

Fig. 19 Connecting the expansion vessel in a single-boiler system

- [1] Expansion vessel
- [2] Gas supply
- [3] Air gap < 1" (25.4 mm)

6.6 Combustion Air and Ventilation Openings

Provisions for combustion and ventilation air must be made in accordance with section 5.3, Air for Combustion and Ventilation, of the National Flue Gas Code, ANSI Z223.1/NFPA 54, or Sections 7.2, 7.3 or 7.4 of CAN/CGA B149, Installation Codes, or applicable provisions of the local building codes.



DANGER:

Fire danger due to flammable materials or liquids.

- Do not store flammable materials and liquids in the immediate vicinity of the boiler.



WARNING:

Boiler Damage.

- Boiler must be clear and free from combustible materials, gasoline and other flammable vapors and liquids, and corrosive liquids and vapors. Never use chlorine and hydrocarbon containing chemicals (such as spray chemicals, solution and cleaning agents, paints, glues etc.) in the vicinity of the boiler
- Do not store and use these chemicals in the boiler room.
- Avoid excessive dust formation and build-up.

**CAUTION:**

Boiler damage and operational failures!
Due to insufficient or improper openings for combustion air and/or ventilation of the boiler room. Provisions for combustion air and ventilation are always required, regardless whether the combustion air is taken from the outside (sealed combustion) or inside (room air for combustion). Insufficient ventilation of the boiler room can lead to high air temperatures. This can result in boiler damage.

- ▶ Make sure that intake and exhaust openings are sufficiently sized and no reduction or closure of openings takes place.
- ▶ When the problem is not resolved, do not operate the boiler.
- ▶ Please note these restrictions and its dangers to the operator of the boiler.

**NOTICE**

- ▶ When one expects contaminated combustion air (near swimming pools, chemical cleaning operations and hair salons), sealed combustion operation is recommended.

All Air form inside the Building (non sealed combustion)

The closet shall be provided with 2 permanent openings communicating directly with an additional room(s). The total input of all gas utilization equipment installed in the combined space shall be considered in making this determination. Each opening shall have a minimum free area of 12" per 1,000 btu/h of total input rating of all gas utilization equipment in the confined space, but no less than 1.002". One opening shall commence within 12" (305 mm) of the top, and one opening shall commence within 12" (305 mm) of the bottom of the enclosure. The minimum dimension of air openings shall be not less than 4" (101.6 mm).

1. Where directly communicating with the outdoors, each opening shall have a minimum free area of 12" per 4,000 Btu/hr of total input rating of all equipment in the enclosure.
2. Where communicating with the outdoors through vertical ducts, each opening shall have a minimum free area of 12" per 4,000 Btu/hr of total input rating of all equipment in the enclosure.
3. Where communicating with the outdoors through horizontal ducts, each opening shall have a minimum free area of 12" per 2,000 Btu/hr of total input rating of all equipment in the enclosure.
4. Where ducts are used, they shall be of the same cross-sectional area as the free area of the opening to which they connect.

All Air from Outdoor (sealed combustion)

The closet shall be provided with two permanent openings, one commencing within 12" (305 mm) from the top, and one commencing within 12" (305 mm) from the bottom of the enclosure. The openings shall communicate directly, or by ducts, with the outdoors or spaces (crawl or attic) that freely communicate with the outdoors. The minimum dimension of air openings shall be no less than 4" (101.6 mm).

**CAUTION:**

Risk of boiler damage due to excessive dust and airborne debris levels.

- ▶ Do not operate the boiler when there is a lot of dust in the boiler room, e.g. due to building work.
- ▶ An air filter must be fitted if the supply of combustion air contains large quantities of dust (e.g. from unpaved roads and tracks or dusty workplaces such as quarries, mines, etc.) or airborne seeds from plants.

6.7 Flue gas adapter**CAUTION:**

- ▶ Do not use lubricants to avoid degradation of the lip rings.

- ▶ When installing PVC vent pipes remove the upper lip ring and insert [1].
- ▶ In case of open venting, use basket [2] on the air intake.
- ▶ When installing parallel PP venting material remove upper lip ring and insert [1] and use PVC/PP PolyPro adapter offered by your local vent supplier.

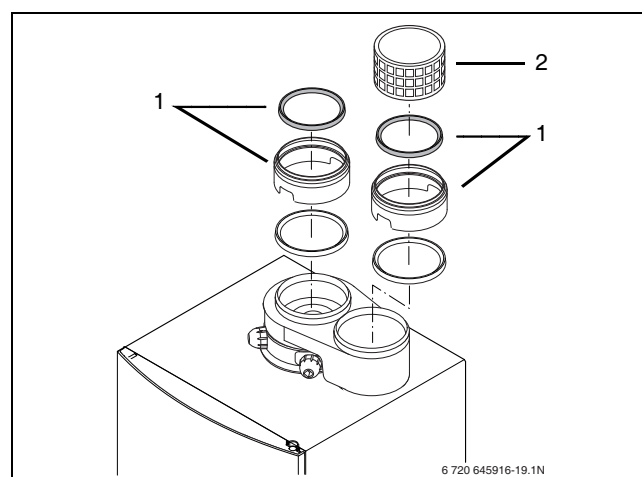

Fig. 20 Connecting the flue gas adapter (parallel)

- ▶ When installing concentric PP venting material remove upper lip ring and insert (→ fig. 20, [1]) and place air intake cap [1].

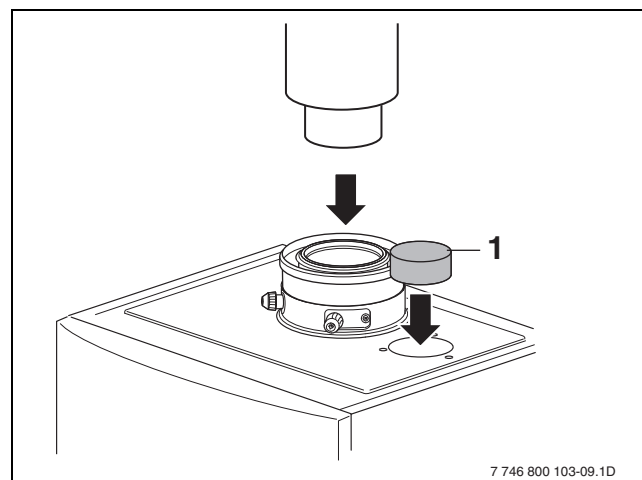

Fig. 21 Placing air intake cap

6.8 Installation of the Exhaust and Air Intake system



NOTICE

- ▶ Consult local and state codes pertaining to special building code and fire department requirements. Adhere to national code requirements.
- ▶ Observe the listed maximum lengths of vent system, which are boiler model dependent. The maximum permissible lengths are listed in table 8, page 22.

Optional vent kits are:

1. Parallel or concentric, horizontal (with approved wall terminal) or vertical

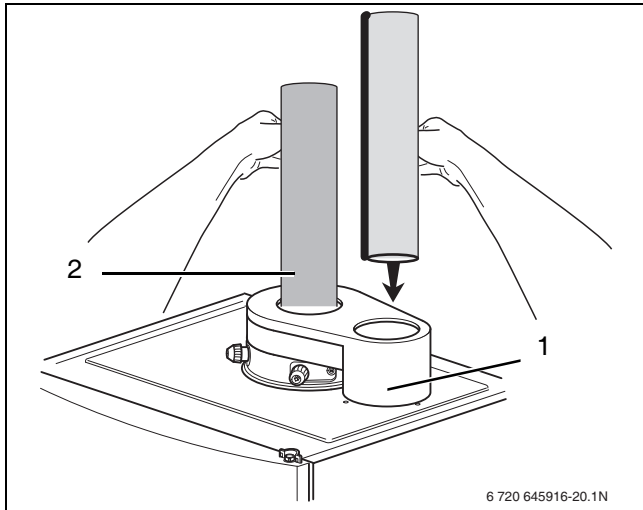

Fig. 22 Vent pipes

The termination shall be at least 4 ft. (1,220 mm) for the U.S. and 6 ft. (1,830 mm) for Canada away from a gas utility meter, service regulator or the like (for room air applications only).

The termination shall terminate at least 4 ft. (1,220 mm) below, 4 ft. (1,220 mm) horizontally from, or 1 ft. (305 mm) above any door, window, or gravity air inlet into any building.

Vent must be at least 12" (305 mm) above grade, anticipated snow line or roof surface (Canada 18" (457 mm) minimum) (→ fig. 23).

Vent termination must be at least 7 ft. (2,135 mm) above a public walkway (→ fig. 24).

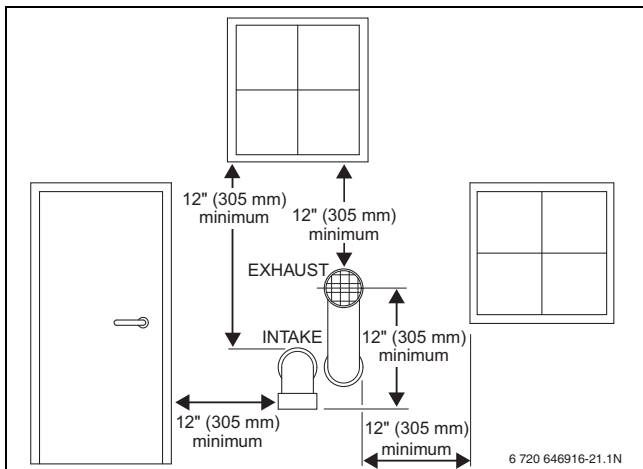

Fig. 23 Vent and air pipe position (1) of a sealed combustion system

Vent must be 3 ft. (915 mm) above any forced air intake within 10 ft. (3,050 mm) (→ fig. 24). Do not extend exposed vent pipe outside the building beyond recommended distance. Condensate could freeze and block vent pipe. Vent should terminate at least 3 ft. (915 mm) away from adjacent walls, inside corners and 5 ft. (1,525 mm) below roof overhang (→ fig. 24). It is not recommended to terminate vent above any door or window, condensate can freeze causing ice formations. Do not use chimney as a raceway if another boiler or fireplace is vented into or through chimney.

All PVC and CPVC vent pipes must be glued, except for the flue gas adapter. Installed you can slide the pipe onto the adapter, properly supported and the exhaust pipe must be pitched a minimum of a ¼" (6.35 mm) per foot back to the boiler. This allows the condensate to drain away.

All non-steel combustion air and vent pipe materials and fittings must comply with the following and must be UL approved venting material:

Item	Material	United States	Canada
4" (100 mm) Intake/combustion air pipe and fitting	PVC schedule 40, 80	ANSI/ASTM D1785	BH gas venting systems, ULC S636 ¹⁾ , Class IIA - PVC, Class IIB - CPVC, Class IIC - Polypropylene
	PVC-DWV	ANSI/ASTM D2665	
	CPVC schedule 40, 80	ANSI/ASTM F441	
	PP M&G Duravent PolyPro and Centrotherm InnoFlue SW	ANSI Cat IV, approved Polypropylene	
4"/6" (100/150 mm) concentric Intake/combustion air pipe and fitting	PP Bosch Concentric	ANSI Cat IV, approved Polypropylene	
	PP-Flex M&G Duravent PolyPro Flex and Centrotherm InnoFlue SW Flex	ANSI Cat IV, approved Polypropylene	
Pipe cement / primer	PVC	ANSI/ASTM D2564	
	CPVC	ANSI/ASTM F493	

Table 6 Approved venting air pipe material

- 1) For installations in Canada, field supplied plastic vent piping must comply with CAN/CGA B149.1 (latest edition) and be certified to the Standard for Type BH Gas Venting systems. ULC S636 Components of this listed system shall not be interchanged with other vent systems or unlisted pipe/fittings. All plastic components and specified primers and glues of certified vent systems must be from a single manufacturer and not mixed with other system manufacturer's vent system parts. The supplied vent connector and separate available wall termination kits are certified as part of the GB162 Boiler.

Approved vent terminations and flue material:

Roof terminals	Flue System (trade name)	Vent / air intake terminal(s)
4"/6" (100/150 mm)	Concentric PVC	IPEX System 636 no. CVK
4"/6" (100/150 mm) (PP)	M&G Duravent PolyPro concentric and Centrotherm Innoflue SW concentric	M&G Duravent Order No. 4PPS-VK (-TC) or Centrotherm ICRT4679
4" (100 mm) (PP)	M&G Duravent - PolyPro Flex Chimney Cap Centrotherm - Innoflue SW Flex Chimney Cap	M&G Duravent order No. 4PPS FCT or Centrotherm ISCP04
Wall terminals	Flue System (trade name)	Vent / air intake terminal(s)
4" (100 mm)	PVC/parallel stainless steel	ANSI/ASTM D1785 or Field Controls
4" (100 mm)	PolyPro Twin pipe termination (PP)	M&G Duravent Order No. 4PPS-HTP
4" (100 mm)	Parallel PVC to ANSI/ASTM D1785	IPEX no. CVK

Table 7 Approved vent terminations and flue material

Roof terminals	Flue System (trade name)	Vent / air intake terminal(s)
4"/6" (100/150 mm)	Concentric PP M&G Duravent PolyPro concentric	Bosch Order No. 7738004825
90°-elbow with inlet screen	PVC/stainless steel	ANSI/ASTM D1785 or Z-Flex/Heat Fab
90°-elbow with inlet screen	PP	M&G Duravent PolyPro or Centrotherm Innoflue SW

Table 7 Approved vent terminations and flue material



NOTICE

- ▶ Use of cellular core PVC (ASTM F891), cellular core CPVC, or Radel® (polyphenolsulfone) in venting systems shall be prohibited.
- ▶ Covering non-metallic vent pipe and fittings with thermal insulation shall be prohibited.
- ▶ A minimum clearance of 4 ft. (1,220 mm) horizontally from and in no case above and below, unless a 4 ft. (1,220 mm) horizontal distance is maintained, from electric meters, gas meters, regulators and relief equipment

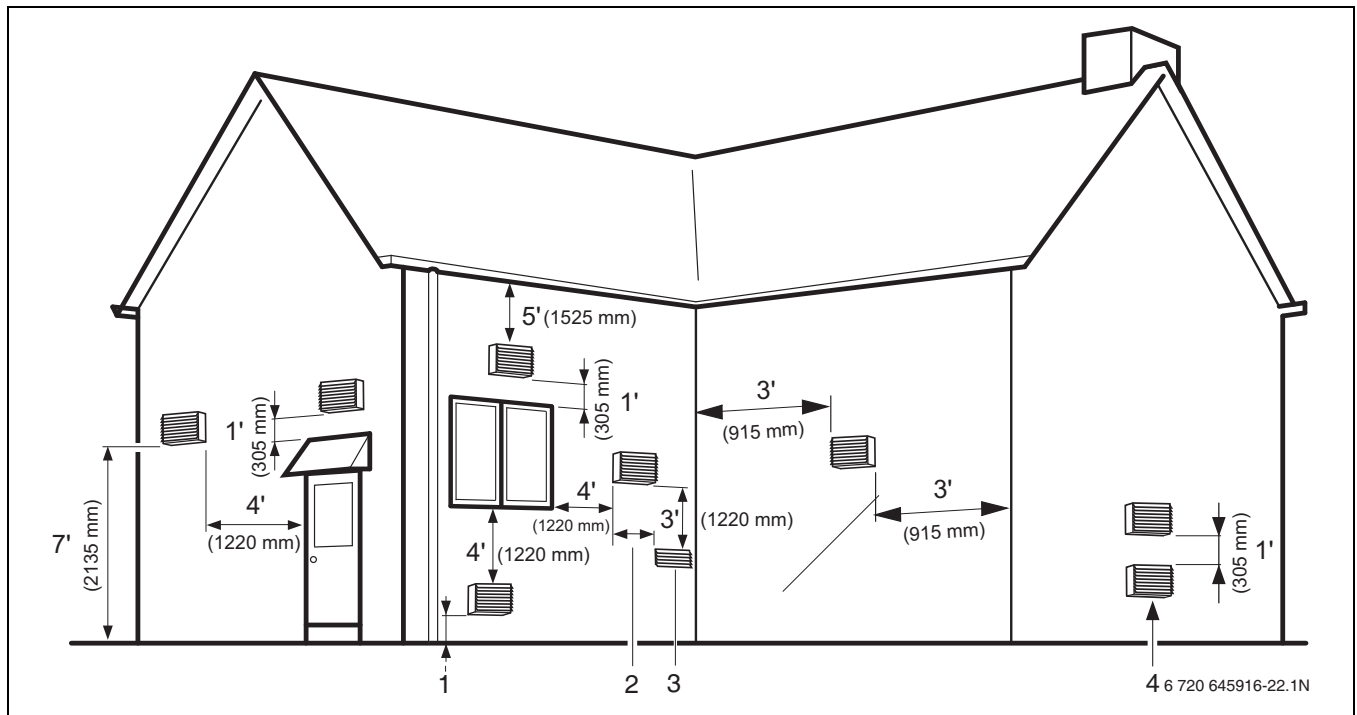

Fig. 24 Vent and air pipe position (2) of a system with combustion air supply from the room (non-sealed)

- [1] Height at Least 1ft (305 mm) above grade and snow line
- [2] Exhaust terminal must be at least 3 ft. (915 mm) above forced air inlet within 10 ft. (3,050 mm)
- [3] Forced Air Inlet
- [4] Gravity Air Inlet

Below are approved examples of vertical and horizontal venting installation



NOTICE

- ▶ Place pipe supports every 5 ft. (1,525 mm) of horizontal and vertical run, beginning with support near boiler.
- ▶ The condensate must be drained in accordance with the applicable rules (→ § 6.5, page 16).
- ▶ Periodic cleaning of the vent terminal and air-intake screens is mandatory.
- ▶ Avoid locating vent terminals near equipment or construction which can be subject to degradation from exhaust gases.

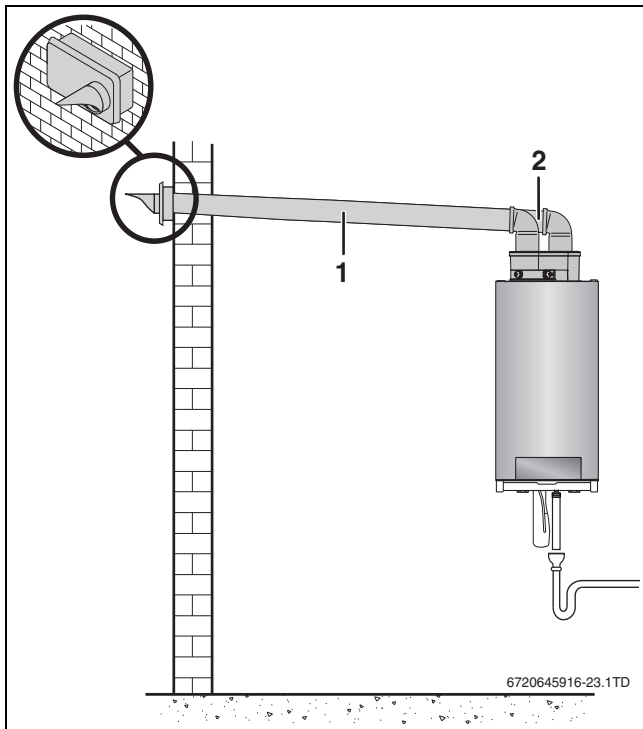

Fig. 25 Horizontal venting system (sealed combustion)

- [1] exhaust 4" (100 mm)
- [2] intake 4" (100 mm)

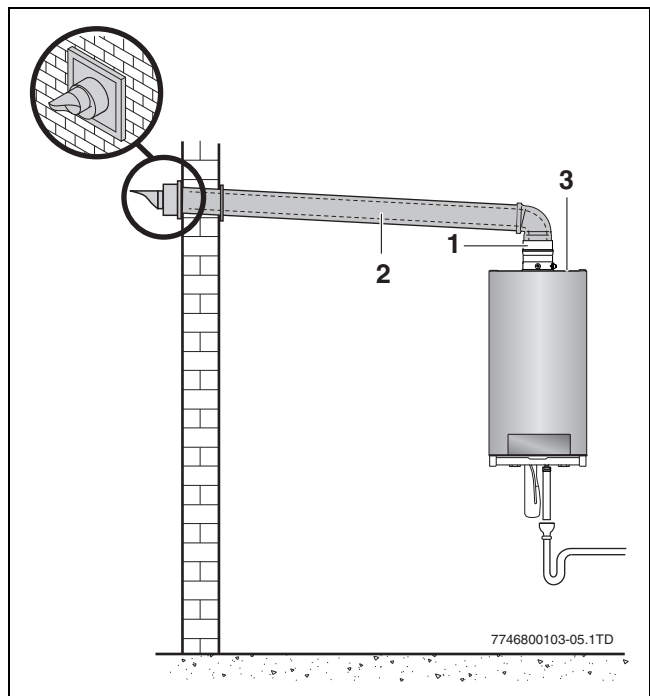

Fig. 26 Concentric horizontal venting system (sealed combustion)

- [1] concentric adaptor 4" (100 mm) / 6" (150 mm)
- [2] exhaust 4" (100 mm) / intake 6" (150 mm)
- [3] place the air intake cap

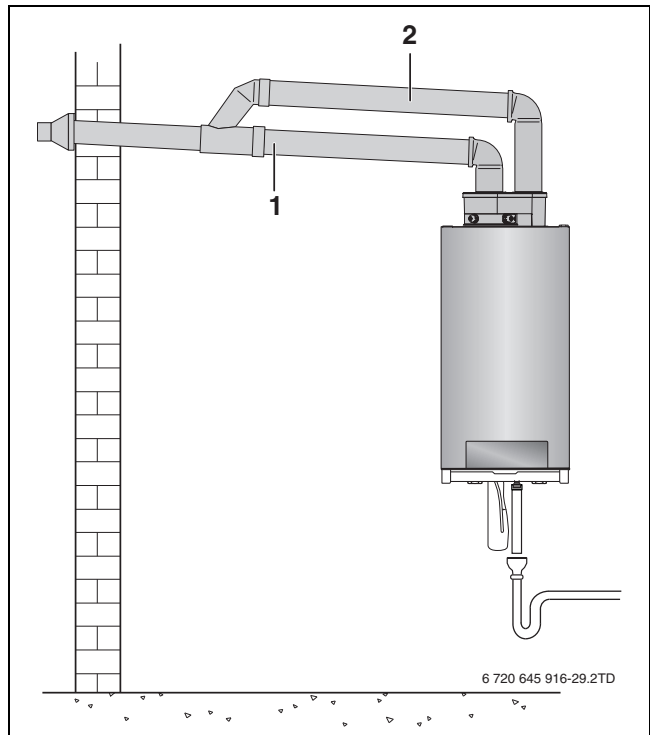

Fig. 27 Horizontal venting system (sealed combustion)

- [1] exhaust 4" (100 mm)
- [2] intake 4" (100 mm)

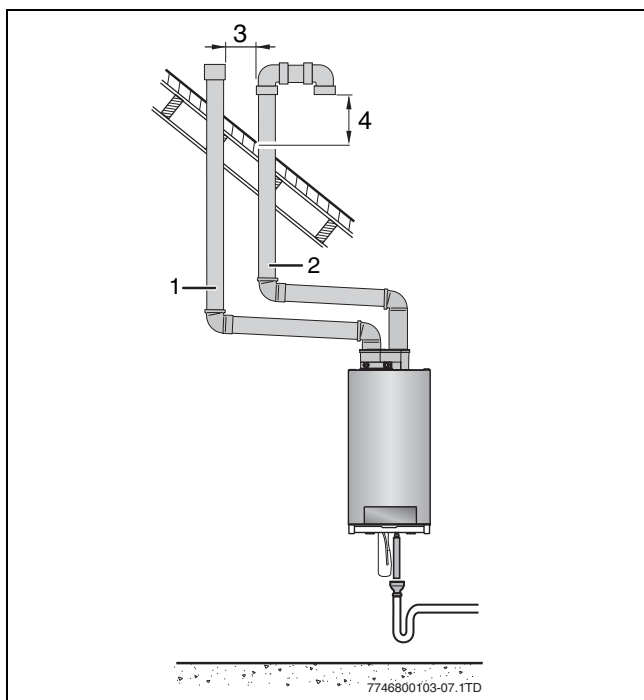

Fig. 28 Vertical parallel venting system (sealed combustion)

- [1] exhaust 4" (100 mm)
- [2] intake 4" (100 mm)
- [3] 10"- 0" MIN (250 mm - 0 mm MIN)
- [4] 12" (300 mm) over max. snow level or 24" (600 mm) whichever is greater

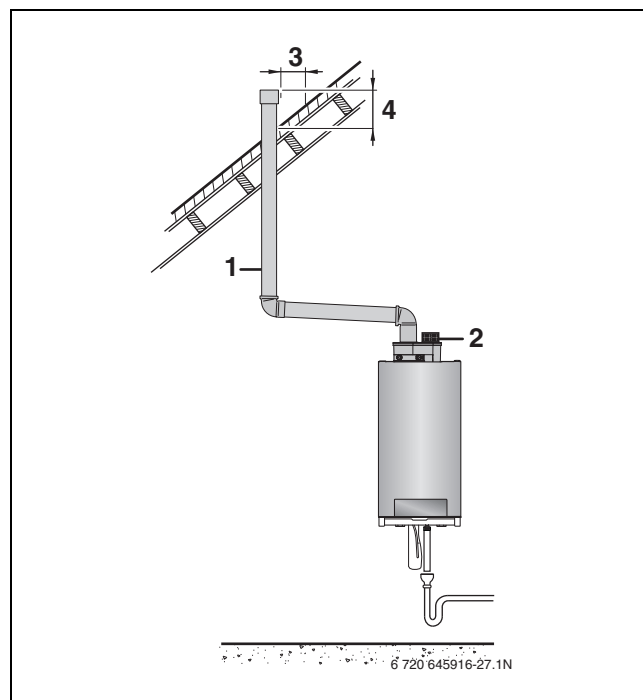

Fig. 30 Vertical venting system (non sealed combustion)

- [1] exhaust 4" (100 mm)
- [2] intake 4" (100 mm)
- [3] 12" (300 mm) over max. snow level or 24" (600 mm) whichever is greater
- [4] 10"- 0" MIN (250 mm - 0 mm MIN)

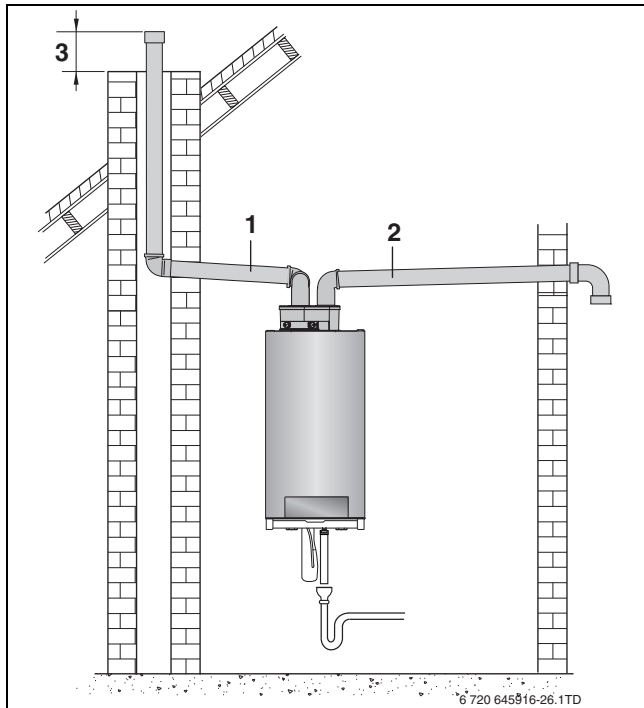

Fig. 29 Vertical venting system (sealed combustion)

- [1] exhaust 4" (100 mm)
- [2] intake 4" (100 mm)
- [3] 12" (300 mm) over maximum snow level or 24" (600 mm) whichever is greater

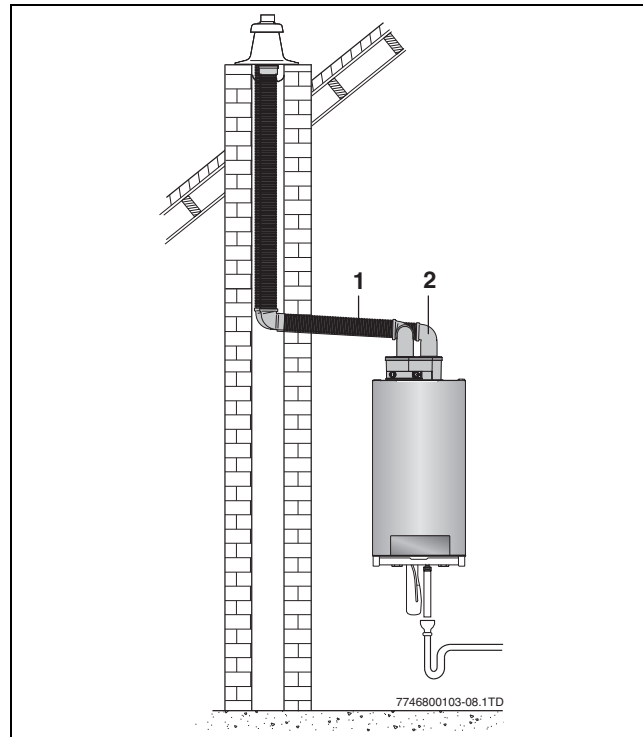

Fig. 31 Flex Chimney Cap (PP) vertical venting system (sealed combustion)

- [1] exhaust 4" (100 mm)
- [2] intake 4" (100 mm)

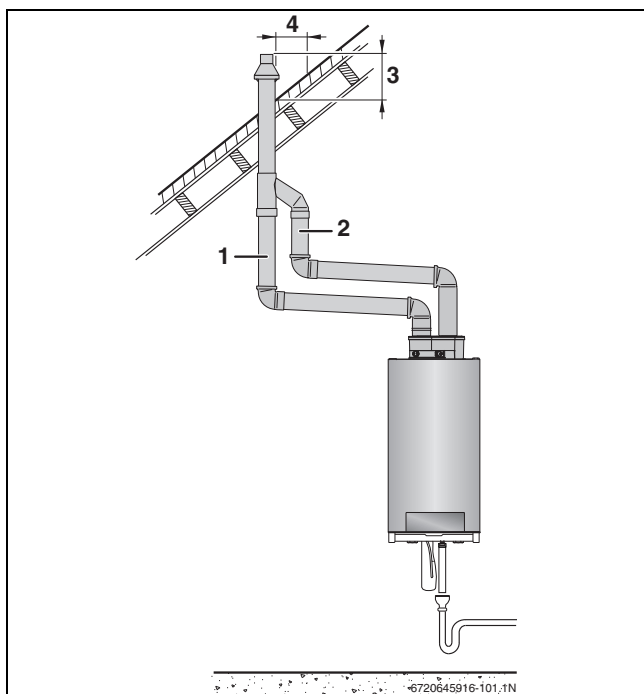

Fig. 32 Vertical concentric venting system (sealed combustion)

- [1] exhaust 4" (100 mm)
- [2] intake 4" (100 mm)
- [3] 12" (300 mm) over max. snow level or 24" (600 mm) whichever is greater
- [4] 10"- 0" MIN (250 mm - 0 mm MIN)

Do not exceed the total equivalent venting length of 100 feet (30,480 mm) maximum requirement each for the intake and exhaust piping.



NOTICE

- ▶ Appliance input rates are based on minimum vent length operation. Longer vent lengths (up to maximum) will reduce the input proportionally.

Friction losses	Equivalent	
	feet	m
45° elbow 4", PVC, CPVC	4	1.22
90° elbow 4", PVC, CPVC	7	2.13
4" plastic pipe per foot, PVC, CPVC	1	0.30
parallel vent kit	2	0.61
concentric PVC terminal 4"/6" (100/150 mm)	20	6.1
45° elbow 4" (100 mm), PolyPro Elbow	7.2	2.2
45° elbow 4"/6" (100/150 mm), PolyPro Elbow	3.7	1.14
90° elbow 4" (100 mm), PolyPro Elbow	11.8	3.6
90° elbow 4"/6" (100/150 mm), PolyPro Elbow	5.6	1.72
4" (100 mm) PolyPro Pipe per foot	3.3	1.0
concentric 4"/6" (100/150 mm), PolyPro Pipe per foot	3.3	1.0
4" (100 mm) PolyPro Flex pipe per foot	6.9	2.1
parallel PolyPro Wall terminal 4" (100 mm)	13.8	4.2
concentric PolyPro Wall terminal 4"/6" (100/150 mm)	20.3	6.2
concentric PolyPro Roof terminal 4"/6" (100/150 mm)	26.0	7.9
PolyPro Roof terminal Flex Chimney Cap	3.3	1.0

Table 8 Friction Loss Equivalent in piping and fittings

See table 8 for the Friction Loss Equivalent in piping and fittings.

Example:

When you end up using 3 x 45°-elbows and the concentric roof terminal, then the total venting length may not exceed 68 ft. (20.72 m).

$$3 \times 45^\circ\text{-elbow} = 3 \times 4 \text{ ft. (1.22 m)} = 12 \text{ ft. (3.66 m)}$$

$$\text{concentric roof terminal } 4"/6" = 20 \text{ ft. (6.10 m)}$$

Total friction loss equivalent = 32 ft. (9.76 m)

Total venting length for this example is:

$$\text{GB162-80 kW/100kW} = 100 \text{ ft. (30.48 m)} - 32 \text{ ft. (9.76 m)} = 68 \text{ ft. (20.72 m)}$$

each for the intake and exhaust piping.



NOTICE

- ▶ The minimum covering wall thickness is 1" (25.4 mm). The maximum covering wall thickness is 16" (406 mm).
- ▶ For direct venting properly reassemble and reseal the vent and air-intake systems.



CAUTION:

- ▶ Vent connectors serving appliances vented by natural draft shall not be connected into any portion of mechanical draft systems operating under positive pressure.

At the time of removal of an existing boiler, the following steps shall be followed with each appliance remaining connected to the common venting system placed in operation, while the other appliances remaining connected to the common venting system are not in operation:

- a) Seal any unused openings in the common venting system.
- b) Visually inspect the venting system for proper size and horizontal pitch and determine there is no restriction, leakage, corrosion and other deficiencies which could cause unsafe condition.
- c) Place in operation the appliance being inspected. Follow the lighting instructions. Adjust thermostat so appliance will operate continuously.
- d) Test for spillage at the draft hood relief opening after 5 minutes of burner operation. Use the flame of a match or candle, or smoke from a cigarette, cigar or pipe.
- e) Any improper operation of the common venting system should be corrected so the installation conforms with the National Fuel Gas Code, ANSI Z223.1/NFPA 54 and/or CAN/CSA B149.1, Natural Gas and Propane Installation Code.

When resizing any portion of the common venting system, the common venting system should be resized to approach the minimum size as determined using the appropriate tables in Part 11 of the National Fuel Gas Code, ANSI Z223.1/NFPA 54 and/or CAN/CSA B149.1, Natural Gas and Propane Installation Code.

**WARNING:**

- ▶ Improper venting of the GB162 boiler can result in excessive levels of carbon monoxide which can result in severe personal injury or death. The boiler must be vented in accordance with the 'Venting of Equipment' section of the latest edition of ANSI Z 223.1 / NFPA 54 Natural Fuel Gas Code and/or the 'Venting systems and air supply for appliances' section of the latest version of CAN/CGA B149.1 Natural Gas and Propane Installation Code in Canada and in accordance with all applicable local building codes.

**NOTICE**

- ▶ To avoid moisture and frost build-up and to maintain clearances to openings on adjacent homes, 45° and 90° elbows or tees may be attached to the end of the vent termination pipe to direct exhaust plumes away from the adjacent structure. The total allowable vent length, maximum number of elbows and distance to air intake restrictions must be adhered to.

6.9 Multiple boiler vent terminal clearance

Vertical terminations:

The combustion air inlet pipe must terminate in a downward position using 2 × 90° elbows. The combustion air inlet pipe shall terminate at least 3 ft (914 mm) horizontally from the center line of the exhaust vent, this is to prevent cross contamination of flue gases into the combustion air stream.

Terminate all exhaust vents at the same height and all combustion air inlets at the same height, while maintaining the minimum 36" (914 mm) height clearance from the exhaust to the down turned 90° elbow and combustion air inlet.

Exhaust vent termination edge shall be at least 24" (610 mm) from the edge of the air inlet pipe of an adjacent heater. Exhaust vent terminations shall be placed at a minimum of 12" (305 mm) center to center (→ fig. 33 and fig. 34).

Air intake terminations may be placed adjacent to each other. The combustion air inlet is part of the direct vent system and not classified as a forced air inlet.

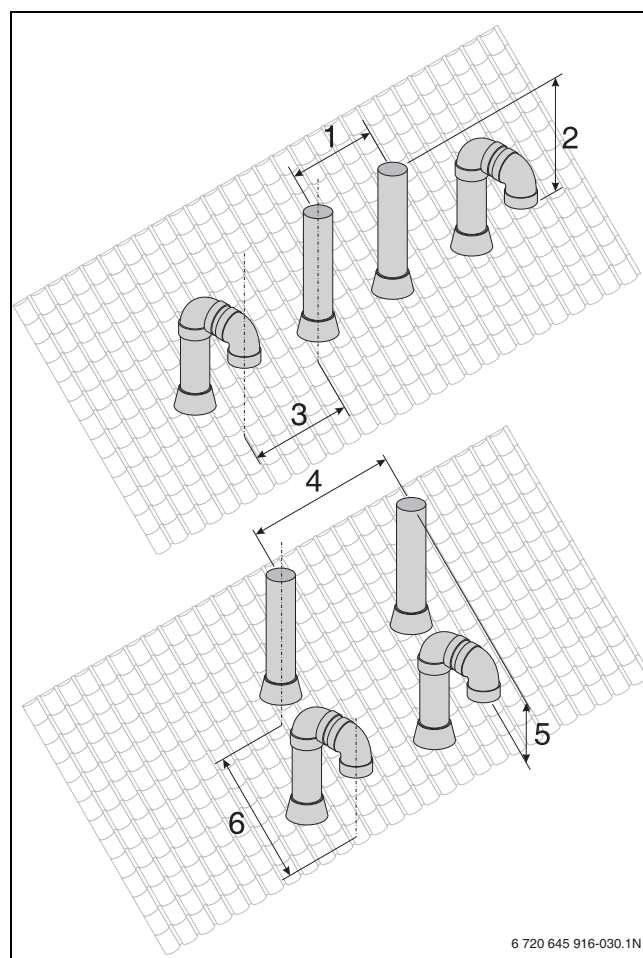

6 720 645 916-030.1N

Fig. 33 Vertical terminations

- [1] minimum 12" (305 mm)
- [2] minimum 36" (914 mm)
- [3] minimum 36" (914 mm)
- [4] minimum 12" (305 mm)
- [5] minimum 36" (915 mm)
- [6] minimum 24" (610 mm)

Horizontal terminations:

Combustion air inlet elbow must terminate at least 12" (305 mm) below exhaust elbow or outlet, but not exceed 15" (381 mm) maximum separation (→ fig. 34).

Horizontal termination shall not extend beyond 18" from the building (based on minimum 12" (305 mm) required separation between intake and exhaust). Exhaust vent vertical rise shall not extend beyond 39" (991 mm) from building penetration to termination elbow (→ fig. 34). Condensate could freeze and block vent pipe.

Terminate all exhaust vents at the same height and all combustion air inlets at the same height, while maintaining the minimum 12" (305 mm) vertical height clearance from between exhaust and combustion air inlet. Exhaust vent termination edge shall be at least 12" (305 mm) laterally from the edge of the air inlet pipe of an adjacent heater. The combustion air inlet is part of the direct vent system and not classified as a forced air inlet.

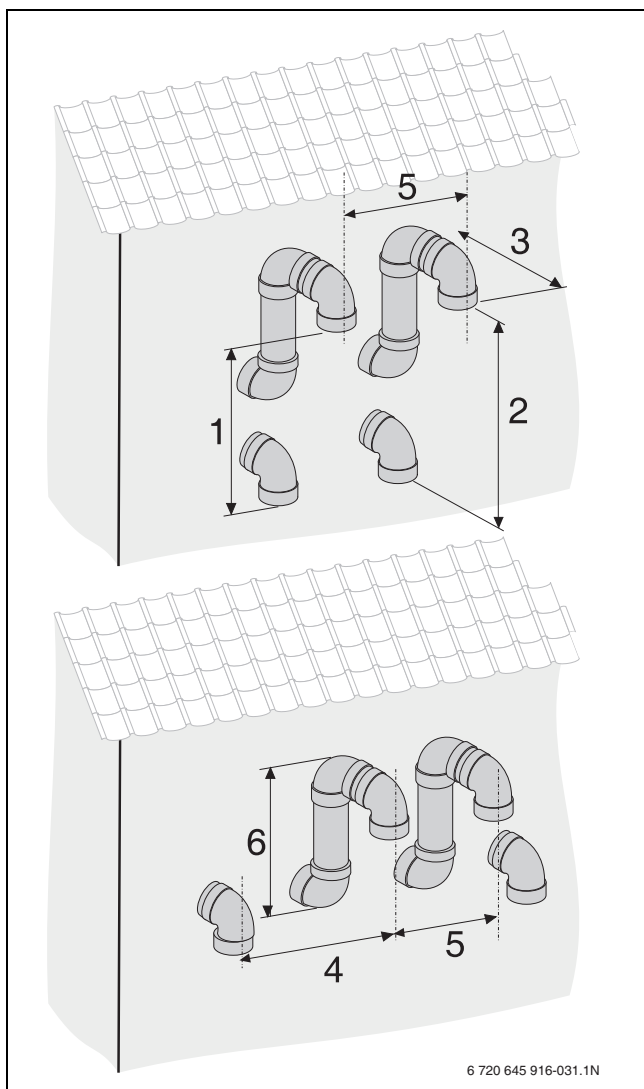

Fig. 34 Horizontal terminations

- [1] minimum 12" (305 mm)
- [2] maximum 15" (381 mm)
- [3] maximum 18" (457 mm)
- [4] minimum 12" (305 mm)
- [5] minimum 12" (305 mm)
- [6] maximum 39" (991 mm)

7 Electrical connections

Devices such as pumps, outdoor sensor and 3-way valve are all connected to the external connection board.

The electrical connections to the boiler must be made in accordance with all applicable local codes and the latest revision of the National Electrical Code, ANSI/NFPA-70.

If installed in Canada, electrical connections should conform with CSA C22.1 Code part 1.

7.1 External connection board connections



WARNING:

Danger of fatal accident due to electric shock.

- ▶ 120 VAC-connections may be present on the external connection board when power is supplied to the boiler.

- ▶ Open the boiler door.
- ▶ Remove the screw to release the cover over the electrical connections and pull the cover upwards (→ fig. 35).

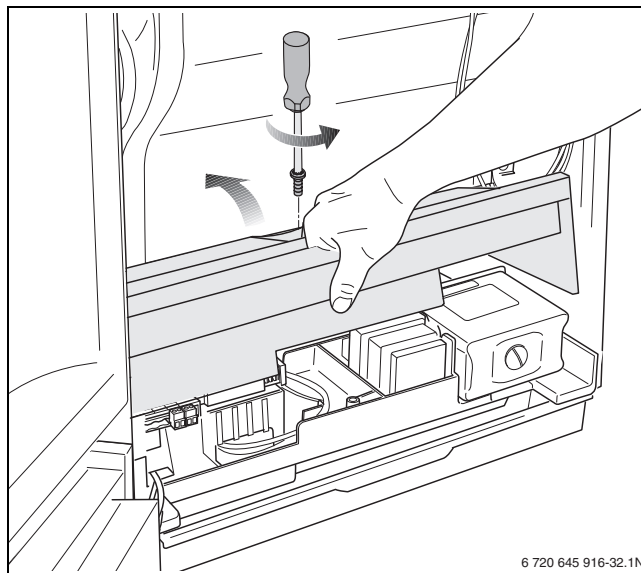

Fig. 35 Removing the cover

7.1.1 Routing the cable through the boiler

- ▶ Route the cable for the low-voltage connections through the opening on the left [1].
- ▶ Route the cable for the 120 VAC connections through the opening on the left [2].
- ▶ Route and attach the cable for the 120 VAC connections using the strain relief clamps [3].
- ▶ Only the 120 V electrical connections require a 14 gauge wire.

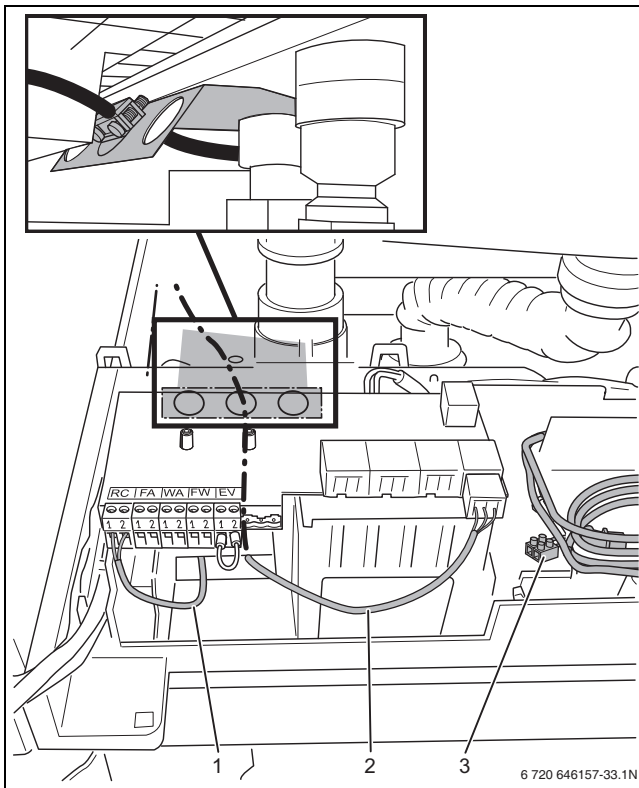

Fig. 36 Routing the cable

7.1.2 Low voltage connections

WARNING:
due to electric shock.

- ▶ Make sure no power is supplied to the boiler when making connections

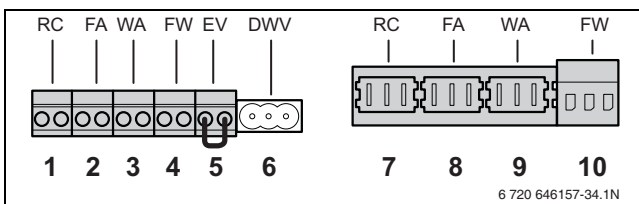

Fig. 37 External connection board connections

no.	abbr.	color	component
1	RC	orange	Room controller RC and EMS bus
2	FA	blue	Outdoor-temperature sensor
3	WA	green	Potential free On/off thermostat
4	FW	grey	DHW temperature sensor
5	EV	red	External switch contact, potential free, e. g. for floor heating safety
6	DWV	green	Connection for external 3-way valve
7	PK	green	External heating pump 120 VAC (for use with non Buderus pump group)
8	PS	grey	DHW tank pump 120 VAC
9	PZ	lilac	DHW recirculation pump 120 VAC
10	Netz	white	Main power connection 120 VAC

Table 9 External connection board connections

▶ Connect all components to the relevant terminals:

RC Terminal - Room Controller

▶ Connect a Room- or Cascade controller to the orange RC terminal (→ fig. 37) (→ § 7.1.4, page 26).

FA Terminal - Outdoor temperature sensor

If outdoor temperature-dependant control operation is used, an outdoor temperature sensor must be connected.

▶ Connect the outdoor temperature sensor to the blue FA terminal (→ fig. 37).

WA Terminal - Potential-free heat demand

With this connection the room temperature-based modulating function of the boiler is not used. This has a negative effect on comfort and energy consumption. The boiler will now only modulate up to the preset space heating water temperature.

▶ Connect the potential-free heat demand contact (On/Off thermostat) or relay panel end switch to the green WA terminal (→ fig. 37).
The maximum allowed resistance of this circuit is 100 Ω.



NOTICE

▶ The RC and WA terminals cannot be used simultaneously.

FW Terminal - DHW temperature sensor

▶ Connect the external DHW temperature sensor to the grey FW terminal, using the harness enclosed with the DHW temperature sensor.



NOTICE

▶ It is not possible to connect more than 1 DHW temperature sensor in the boiler.
▶ Connect a DHW temperature sensor suitable for this particular boiler.

EV Terminal - External switching contact

An external switch contact can be used, i.e. to safeguard a floor heating system so that the heating water temperature will not become too high etc.

When the external switch contact is opened, the boiler will be switched off for heating operation and for domestic hot water operation. The pump continues to run for the run-over time set on the boiler.

▶ Remove the cable from the EV terminal (→ fig. 37).
▶ Connect the external switch contact to the red EV terminal (→ fig. 37).

DWV Terminal - 3-way valve

▶ Do not use this connection.

7.1.3 120 VAC connections



NOTICE

▶ Use the 120 VAC connections for specific hydraulic configurations and a corresponding controller.

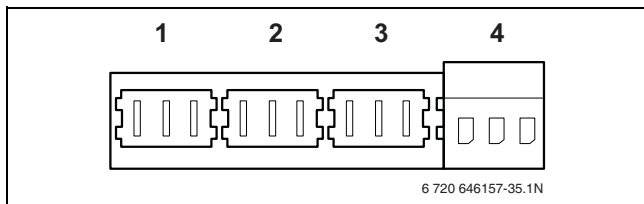

Fig. 38 120 VAC Connections

- [1] PK
- [2] PS
- [3] PZ
- [4] 120 VAC

PK Terminal - External pump

► Connect the external heating or system pump (for situations where the pump of the Buderus pump group is not used) to the green PK terminal (→ fig. 38). The maximum allowed connected load of the pump = 100 Watts.

PS Terminal - DHW pump

► Connect the DHW pump to the grey PS terminal (→ fig. 38). The maximum allowed connected load of the pump = 100 Watts.

PZ Terminal - DHW circulation pump

► Connect the DHW circulation pump to the lilac PZ terminal (→ fig. 38). The maximum allowed connected load of the pump = 100 Watts.

Mains connector



WARNING:
Connecting incoming power

► Ground the boiler electrically in accordance with local codes, or in absence of local codes, with the National Electrical Code, ANSI/INFPA 70 and/or the CSA C22.1, Electrical Code.

► Install a 120 VAC cable to the boiler mains connection.

7.1.4 Controller



NOTICE

► It is not possible to connect more than 1 room controller.

The following controls can be connected to the boiler:

- Logamatic RC35 room controller,
- Logamatic 4323 controls,
- Control with contact for potential free heat demand
- Error reporting module EM10, 0 – 10 V input (can be used to convert a 0 – 10 V signal to a modulating signal),
- MCM boiler cascade module up to 16 boilers.

To install additional modules in the boiler, see § 7.2 "Installing function modules (accessories)", page 26.

Installing an RC35 controller as an outdoor reset control in the boiler

- Open the control panel cover.
- Remove the cover [1].
- Install the RC35 in the slot [2].

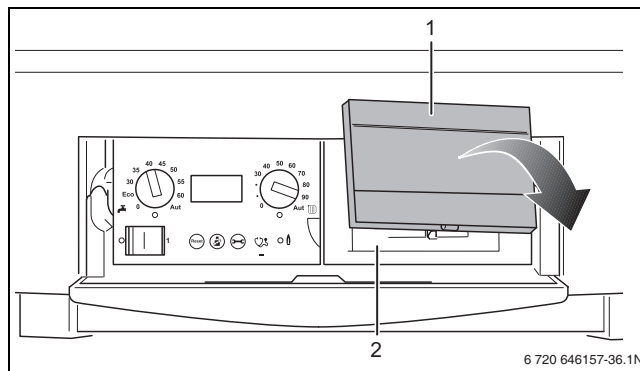



Fig. 39 Installing the room controller

7.2 Installing function modules (accessories)



NOTICE

► Refer to the installation instructions of the relevant function modules for information about installation and combination possibilities.

The following function modules (accessories) can be connected to the boiler:

- Heat demand 0-10 V module EM10,
- Error reporting module EM10,
- Switch module WM10,
- Mixing module MM10.

The function modules (accessories) can be installed in 2 ways:

- in the boiler (max. 2), see § 7.2.1.
- outside the boiler, see § 7.2.2.

7.2.1 Installing function modules in the boiler

- Loosen the screw (step 1).
- Pull open the drawer (step 2).

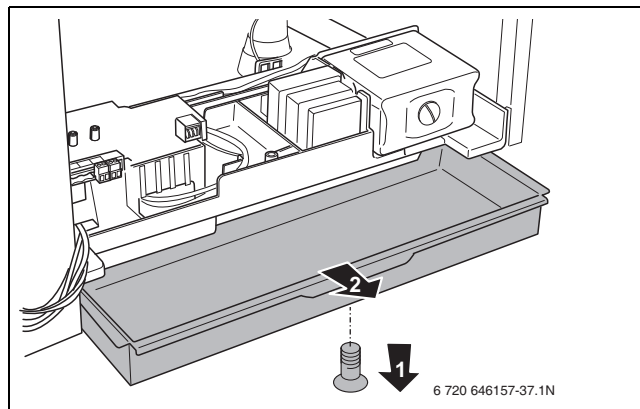

Fig. 40 Opening the drawer

- ▶ Install the wall bracket in the relevant slots in the drawer (→ fig. 41).

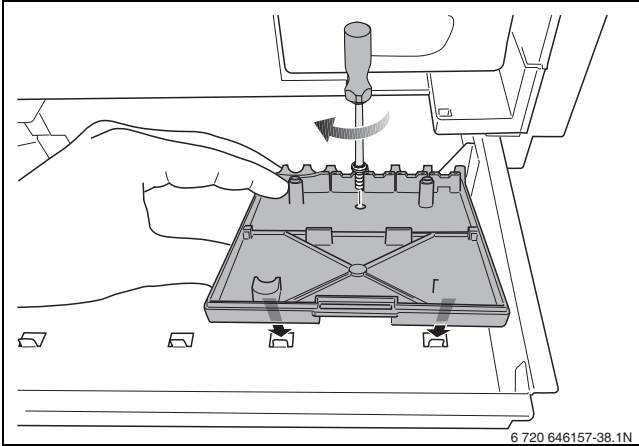

Fig. 41 Installing the wall bracket

- ▶ Click the function module(s) into position in the wall bracket (→ fig. 42).

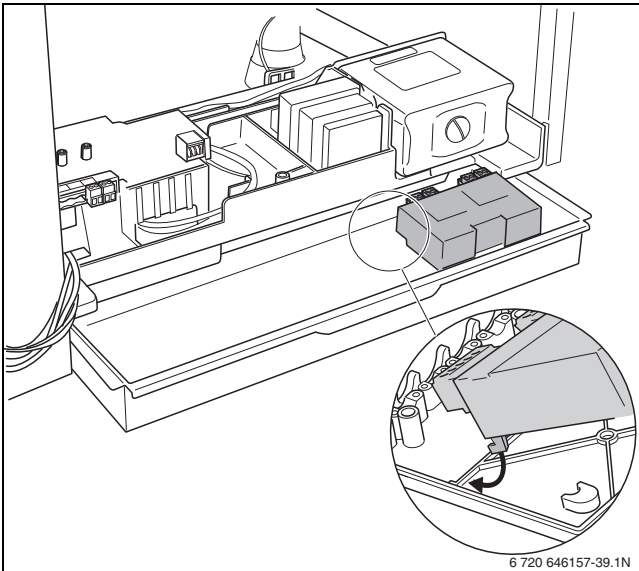

Fig. 42 Clicking the function module into position

- ▶ Remove the drawer.
- ▶ Remove the covers of both free connectors on the function module connection cables (→ fig. 43).

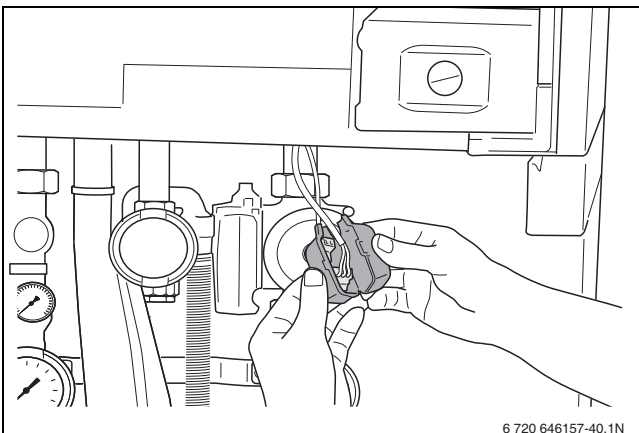

Fig. 43 Removing the covers

- ▶ Slide the drawer back into the boiler.
- ▶ Connect the free 120 VAC mains cable (→ fig. 43) to the module [1]. If more modules are used, the 120 VAC supply for the second module can be taken from the first module using the cable enclosed with the module.

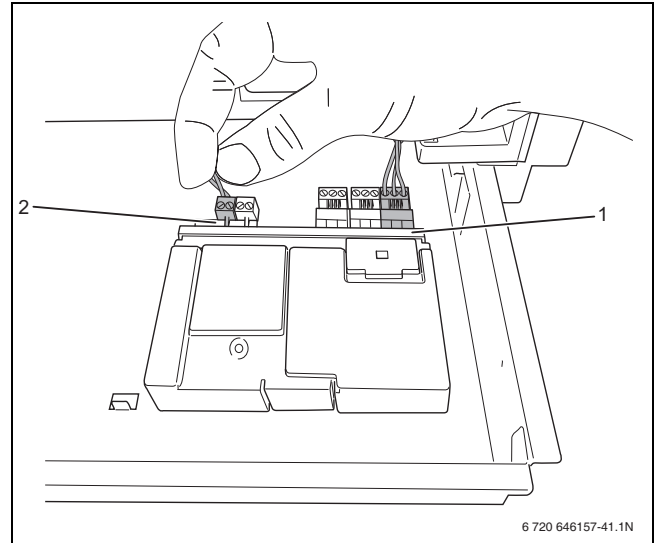

Fig. 44 Interconnecting modules



NOTICE

- ▶ The module may have the letters RC or EMS above the connection (→ fig. 45, [1]).

- ▶ Connect the free connector of the EMS bus connecting cable (→ fig. 44) to the first module (→ fig. 45).
- ▶ If more modules are used, the EMS bus connection for the second module may be branched off from the first module using the cable enclosed with the module (→ fig. 44 and fig. 45).

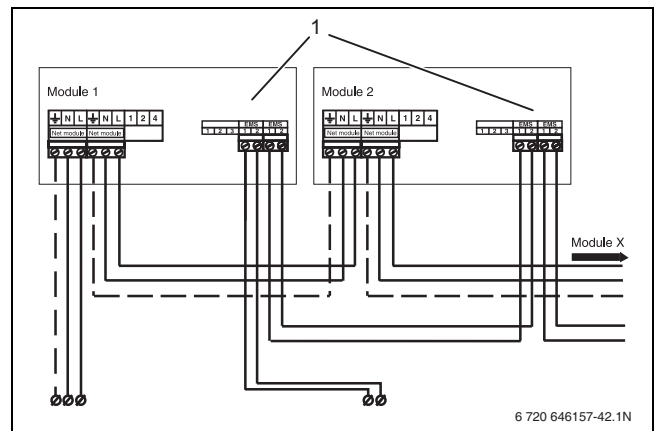

Fig. 45 Connecting several modules



NOTICE

Pay attention to the polarity when using an EMS bus connection cable

- ▶ Connect the wire from terminal 1 to terminal 1 and from terminal 2 to terminal 2 (→ fig. 44 and fig. 45).

7.2.2 Installing function modules outside the boiler

- ▶ Install the module on the wall according to the installation instructions of the module.
- ▶ Make an EMS bus connection cable using a 2-core cable and the connector enclosed with the module (→ fig. 46).

Important: Use the connector of the same color as the connections on the module.

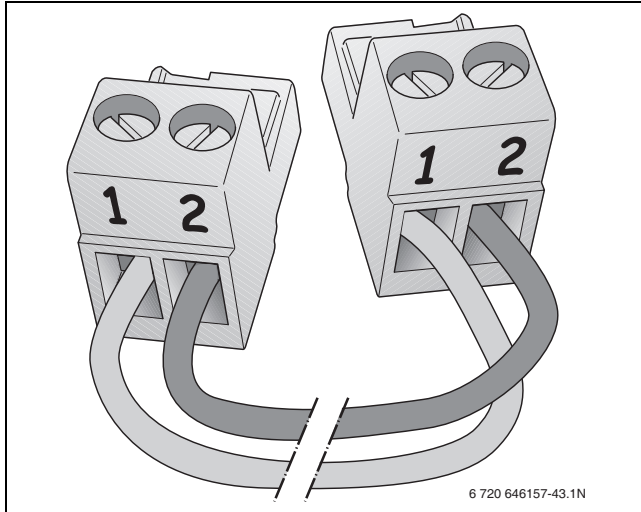

Fig. 46 EMS bus polarity



NOTICE

Pay attention to the polarity when using an EMS bus connection cable.

- ▶ Connect the wire from terminal 1 to terminal 1 and from terminal 2 to terminal 2 (→ fig. 44 and fig. 45).

- ▶ Connect the EMS bus connection cable to the orange RC connection of the external connection board [1].

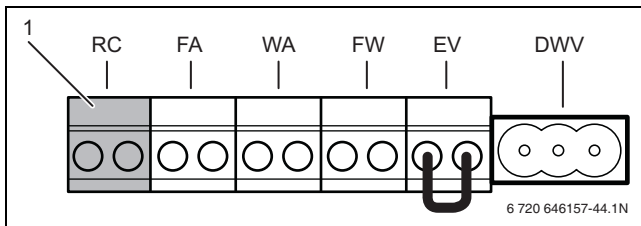

Fig. 47 External connection board - Room controller RC and EMS bus (connection color orange)

- ▶ To connect other modules, see § 7.2.1.

7.3 Electrical wiring diagram



CAUTION:

Wiring errors can cause improper and dangerous operation.

- ▶ Label all wires prior to disconnection when servicing.
- ▶ Verify proper operation after servicing.

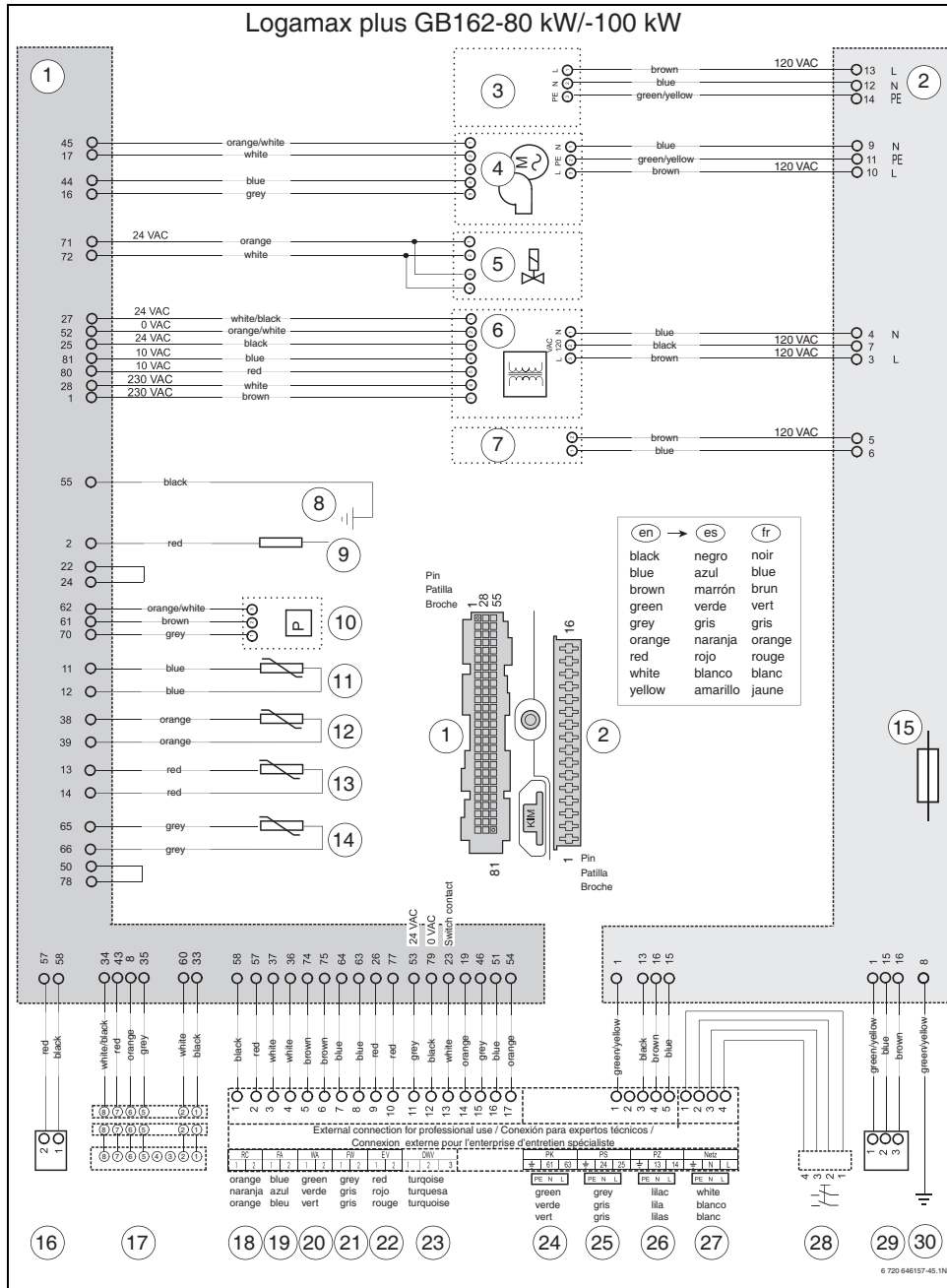

- [9] Ionization
- [10] Pressure sensor
- [11] Return sensor
- [12] Safety-temperature sensor
- [13] Supply sensor
- [14] Flue gas sensor
- [15] Fuse (5 amp. FAST, sand filled)
- [16] BUS function modules
- [17] Connector for BC10 Basic Controller
- [18] Room controller RC and EMS bus
- [19] Outdoor temperature sensor
- [20] On/off temperature controller (potential free)
- [21] DHW sensor
- [22] External switch contact (potential free, e.g. floor heating)
- [23] External 3-way valve
- [24] Boiler pump (120 VAC, max. 100 W)
- [25] DHW pump (pump 120 VAC, max. 100 W)
- [26] DHW re-circulation pump (pump 120 VAC, max. 100 W)
- [27] Main power connection 120 V/ 60 Hz, max. permissible 5 A
- [28] Mains switch
- [29] 120 VAC function module
- [30] Ground

IMPORTANT

The wires in this mains lead are colored in accordance with the following code:

GREEN AND YELLOW - EARTH; BLUE - NEUTRAL; BROWN - LIVE

As the colors of the wires in the mains lead of the appliance may not correspond with the colored markings identifying the terminals in your connector proceed as follows:

The wire colored green and yellow must be connected to the terminal on the connector marked with the letter E or by the earth symbol (⏏) or colored green or green-and-yellow. The wire colored brown must be connected to the terminal marked with the letter L or colored red. The wire colored blue must be connected to the terminal marked with the letter N or colored black.

WARNING

THIS APPLIANCE MUST BE EARTHED. Ensure that your appliance is connected correctly - if you are in any doubt consult a qualified electrician. For location of individual components, see service section and the exploded views in this manual.

Fig. 48 Electrical wiring diagram

- [1] 81-pole connector (AC 0, 10, 24 and 230 V)
- [2] 16-pole connector (AC 120 V)
- [3] Connection for pump in connection kit (accessory)
- [4] Fan
- [5] Gas valve
- [6] Transformer
- [7] Glow ignitor
- [8] Earth

8 Operation

8.1 BC10 basic controller

The boiler is fitted with a control unit, the BC10 basic controller. This controller can be used to control the heating system.

- ▶ Push on the control panel (→ fig. 49) to get access to the BC10 basic controller (→ fig. 50).

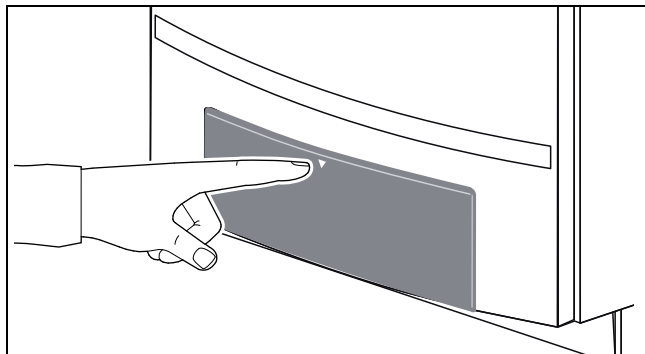

Fig. 49 Opening the control panel

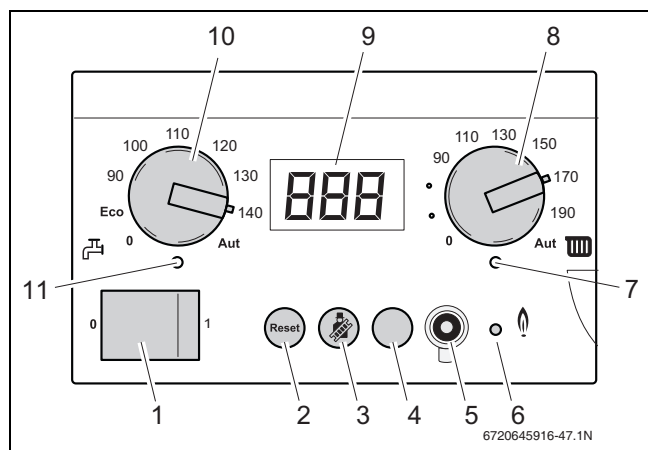

Fig. 50 BC10 basic controller

- [1] Main power switch
- [2] "Reset" button
- [3] "Chimney sweep" button
- [4] "Service" button
- [5] Service Tool Connector
- [6] LED "Burner operation"
- [7] LED "Central heat demand"
- [8] Space heating water temperature knob
- [9] Display
- [10] DHW temperature knob
- [11] LED "DHW demand"

The BC10 basic controller has the following components:

"Main power switch" (→ fig. 50, [1])

The main power switch is used to switch the boiler ON and OFF.

"Reset" button (→ fig. 50, [2])

If a fault has occurred you may have to restart the boiler by pressing the "Reset" button.

This is only required in the event of a "locking" fault. "Blocking" faults are reset automatically as soon as their cause has been corrected.

The display shows rE during the reset operation.



CAUTION:

- ▶ Limit the space heating water temperature to the maximum flow temperature of the floor heating circuit.
- ▶ A power interruption discontinues manual operation. Frost damage may occur.

"Chimney sweep" button (→ fig. 50, [3])

The "Chimney sweep" button is used to put the boiler into flue gas test, service or manual operation mode. The BC10 maximum heating water temperature setting applies.

- The flue gas test enables the boiler to be run in full-load operation manually for a short period (→ table 12, page 31).
- The service mode enables the boiler to be run in part-load operation manually for a short period. Measurements and settings can be carried out on the boiler (→ table 13, page 31).
- The manual operation mode enables the boiler to be operated manually for a longer period. Use this mode when the control system has not been installed yet or is out of order (→ table 14, page 32).

"Service" button (→ fig. 50, [4])

The "Service" button is used to display the current space heating water temperature, the current system pressure etc.

Service Tool connection (→ fig. 50, [5])

For further information please contact Buderus.

LED "Burner operation" (→ fig. 50, [6])

The LED "Burner operation" lights when the burner of the boiler is active and is extinguished when the burner is switched OFF.

The LED "Burner operation" indicates the burner status.

LED	Status	Explanation
ON	Burner operational	Boiler water is being heated.
OFF	Burner off	The space heating water temperature has reached the target value and there is no heat demand.

Table 10 Meanings of LED "Burner operation" indications

LED "Central heat demand" (→ fig. 50, [7])

The LED "Central heat demand" lights when there is a heat demand and is extinguished when the heat demand is no longer present.

Space heating water temperature knob (→ fig. 50, [8])

The Space heating water temperature knob is used to set the upper space heating water temperature limit. The unit is °F.

Display (→ fig. 50, [9])

The appliance display values, display settings and display codes can be read out from the display. If a fault occurs the display will immediately show the accompanying fault code. The fault code flashes if a locking fault has occurred.

DHW temperature knob (→ fig. 50, [10])

The DHW temperature knob is used to select the required temperature of the hot water in the hot water cylinder. The unit is °F (→ table 20, page 41).

LED "DHW demand" (→ fig. 50, [11])

The LED "DHW status" lights when there is a DHW request and is extinguished when the DHW demand is no longer present.

8.2 BC10 operating instructions

You can navigate through the menu structure of the boiler on the BC10 using the “Reset” button, the “Chimney sweep” button, the “Service button” (→ fig. 50, [2, 3 and 4]) and the display (→ fig. 50, [9]).

The menu structure consists of 5 menus:

- Normal Operation menu, → table 11
- Flue Gas Test menu, → table 12
- Service Mode menu, → table 13
- Manual Operation menu, → table 14
- Settings menu, → table 15.

Normal Operation menu	
Step 1	Shows currently measured space heating water temperature in °F (→ § 13.3, page 49).
Step 2	Press the button.
Step 3	Shows currently measured system pressure in psi (→ § 13.3, page 49).
Step 4	Press the button.
Step 5	Current display code. In this case: Operating phase: Boiler in heating mode (→ § 13.5, page 50).
Step 6	After 5 seconds the display returns to step 1, or
Step 7	Press the button.

Table 11 Normal operation

Flue Gas Test menu	
Step 1	Shows currently measured space heating water temperature in °F (→ § 13.3, page 49).
Step 2	To activate the flue gas test: Press and hold the button for more than 2 but not longer than 5 seconds.
Step 3	The non-flashing dot in the right-hand bottom corner of the display shows the flue gas test has been activated: <ul style="list-style-type: none"> • the boiler is in heating mode at a capacity of 100% for a maximum of 30 minutes, • space heating water temperature is as set on the BC10 basic controller, • DHW mode is not possible.
Step 4	Press the button.
Step 5	Shows currently measured system pressure in psi (→ § 13.3, page 49).
Step 6	Press the button.
Step 7	Display code. Operating phase: The boiler is in flue gas test mode (→ § 13.5, page 50).
Step 8	Press the button.
Step 9	Shows currently measured space heating water temperature in °F (→ § 13.3, page 49).
Step 10	After 30 minutes or after a power interruption the flue gas test ends automatically. To end manually press and hold the button for more than 2 seconds until the dot disappears.

Table 12 Flue gas test

Service Mode menu	
Step 1	Shows currently measured space heating water temperature in °F (→ § 13.3, page 49).
Step 2	To activate service mode 1st step: Press and hold the button for more than 2 but not longer than 5 seconds.
Step 3	The non -flashing dot is shown in the right-hand bottom corner of the display shows the boiler is now in Flue gas test mode.
Step 4	To activate service mode 2nd step: Simultaneously press and hold the + buttons for more than 2 seconds.
Step 5	Display shows the maximum capacity setting during heating mode in % (→ § 13.4, page 49). In this case: = 100%. Service mode has been activated. You can now adjust the boiler performance to partial load, i.e. to check the gas/air ratio or the ionization current.
Step 6	Press and hold the button until the display shows . Display setting: with a 80-kW boiler and , with a 100-kW boiler. Minimum capacity setting during heating mode in % (→ § 13.4, page 49). The boiler will reduce its performance to 25% or 20% respectively within a couple of seconds. The space heating water temperature set on the BC10 basic controller (control panel) applies now. Check the gas/air ratio or the ionization current and if necessary set the gas/air ratio according to § 9.8 or § 9.10.
Step 7	Press the button.
Step 8	This parameter shows the pump run-over time in minutes that starts when the heating mode has ended (→ § 13.4, page 49).

Table 13 Service mode

Service Mode menu	
Step 9	Press the button.
Step 10	This parameter indicates the DHW mode status setting (→ § 13.4, page 49).
Step 11	Press the button.
Step 12	Shows currently measured space heating water temperature in °F (→ § 13.3, page 49).
Step 13	Press the button.
Step 14	Shows currently measured system pressure in psi (→ § 13.3, page 49).
Step 15	Press the button.
Step 16	Display code: Operating phase: The boiler is in service mode (→ § 13.5, page 50).
Step 17	After 30 minutes or after a power interruption the flue gas test ends automatically. To end manually press and hold the button for more than 2 seconds until the dot disappears.
Step 18	The boiler input rating drops to the preset capacity (→ table 15, page 32).

Table 13 Service mode

Manual Operation menu	
Step 1	Shows currently measured space heating water temperature in °F (→ § 13.3, page 49).
Step 2	To activate manual operation: Press and hold the button for more than 5 seconds.
Step 3	A flashing dot in the right-hand bottom corner of the display shows manual operation is active. This means that the boiler is permanently in heating mode: Space heating water temperature is as set on the BC10 basic controller. The LED “Heating system status” lights. DHW mode is possible during manual operation.
Step 4	Press the button.
Step 5	Shows currently measured system pressure in psi (→ § 13.3, page 49).
Step 6	Press the button.
Step 7	Display code. Operating phase (→ § 13.5, page 50). The boiler is in manual operation mode. During manual operation the “Settings” menu (table 15 from step 2) can be used to temporarily change the target boiler performance. NOTE: If the boiler output has been changed temporarily, this must be set again after ending manual operation, according to the “Settings” menu (→ table 15, page 32).
Step 8	Press the button.
Step 9	Shows currently measured space heating water temperature in °F (→ § 13.3, page 49).
Step 10	After a power interruption manual operation ends automatically. To end manually press and hold the button for more than 2 seconds until the dot disappears.

Table 14 Manual operation

Settings menu	
Step 1	Shows currently measured space heating water temperature in °F (→ § 13.3, page 49).
Step 2	To open the “Settings” menu: Press and hold the + buttons for more than 2 seconds.
Step 3	This shows the “Settings” menu is open. You can adjust the setting of this parameter.
Step 4	Target output. Adjust as follows, or go to step 5. Lower: Decrease the modulation rate with the button. The minimum setting for boilers at sea level is = 25% with an 80 kW boiler and = 20% with a 100 kW boiler. Higher: Increase the modulation rate with the button. The maximum setting is = 100%. This is equal to the factory setting.
Step 5	Press the button.
Step 6	Pump run-over time in minutes (starts when the heating mode has ended). Adjust as follows or go to step 7. Lower: Decrease the time with the button. The minimum setting is = 0 minutes. The factory default setting is 5 minutes. CAUTION! Do not set the post purge time to less than 5 minutes. Higher: Increase the time with the button. The maximum setting is = 60 minutes or = 24 hours.
Step 7	Press the button.
Step 8	DHW mode status setting. Adjust as follows or go to step 9. DHW mode can be switched OFF or ON. This setting has priority over other DHW mode settings, such as those made on the room thermostat. Set the DHW mode with the or buttons. means “ON”, means “OFF”. NOTE: Setting also switches OFF the hot water cylinder frost protection.
Step 9	After 5 seconds or after a power interruption the settings menu ends automatically. To end manually press the button. Any adjustments that you have made have been confirmed.

Table 15 Settings

9 Start-up procedure

There are several steps involved in starting up the boiler. Complete the commissioning record log book after carrying out all activities described in this chapter (→ § 15.1, page 57).

FOR YOUR SAFETY READ BEFORE OPERATING

WARNING: If you do not follow these instructions exactly, a fire or explosion may result causing property damage, personal injury or loss of life.

A. This appliance does not have a pilot. It is equipped with an ignition device which automatically lights the burner. Do **not** try to light the burner by hand,

B. **BEFORE OPERATING** smell all around the appliance area for gas. Be sure to smell next to the floor because some gas is heavier than air and will settle on the floor.

WHAT TO DO IF YOU SMELL GAS

- Do not try to light any appliance.
- Do not touch any electric switch; do not use any phone in your building.
- Immediately call your gas supplier from a neighbor's phone. Follow the gas supplier's instruction.
- If you cannot reach your gas supplier, call the fire department.

C. Use only your hand to push in or turn the gas control knob. Never use tools. If the knob will not push in or turn by hand, don't try to repair it, call a qualified service technician. Force or attempted repair may result in a fire or explosion.

D. Do not use this appliance if any parts have been under water. Immediately call a qualified service technician to inspect the appliance and to replace any part of the control system and any gas control which has been under water.

OPERATING INSTRUCTIONS

1. **STOP!** read the safety information above on this label.
2. Turn off all electric power to the appliance.
3. Set the thermostat or other operating control to lowest setting.
4. This appliance is equipped with an ignition device which automatically lights the burner. Do **not** try to light the burner by hand.
5. Close main gas shut off valve.
6. Wait (5) minutes to clear out any gas. Then smell for gas. Including near the floor. If you smell gas, **STOP!** Follow "B" in the safety information above on this label. If you don't smell gas, go to the next step.
7. Open main shut off valve.
8. Set the thermostat or other operation control to desired setting.
9. Turn on all electric power to the appliance.
10. If the appliance will not operate, follow the instruction "To Turn Off Gas To Appliance" and call your service technician or gas supplier.

TO TURN OFF GAS TO APPLIANCE

1. Turn off all electric power to the appliance if service is to be performed.
2. Set the thermostat or other operating control to lowest setting.
3. Close main gas shut off valve.

708.375A - 2172B
6720645916-48.1N

Fig. 51 Safety sticker

9.1 Check for gas leaks

Prior to the initial start-up check that the gas flow pipe work is gas-tight; this must be confirmed in the start-up report.



WARNING:

- ▶ The boiler and its manual gas shutoff valve must be isolated from the gas supply piping system during any pressure testing of that system, exceeding 0.5 psi (34.5 mbar). The maximum test pressure allowed at the manual gas shutoff valve inlet is 0.5 psi (34.5 mbar).
- ▶ Cover endangered positions before leak testing.
- ▶ Do not spray the leak testing agent onto cables, plugs or electrical connection lines. Do not allow it to drip onto them either.



DANGER:

Leaks may be caused to pipes and screw connections during commissioning and maintenance activities.

- ▶ Carry out a proper leak test.
- ▶ Only use approved leak detection agents for leak detection.

- ▶ If 0.5 psi (34.45 mbar) or less, slowly open the gas valve by pushing on the gas valve and turning it ¼ rotation in a counter-clockwise direction (→ fig. 52). The gas valve is open when it is in the vertical position.
- ▶ Shut off the appliance from the power supply.
- ▶ Check the new conduit section up to and including its connection (i.e. direct sealing location) to the gas fitting for leaks, using a foaming product. The maximum test pressure allowed at the manual gas shutoff valve inlet is 0.5 mbar (0.2" W.C.).

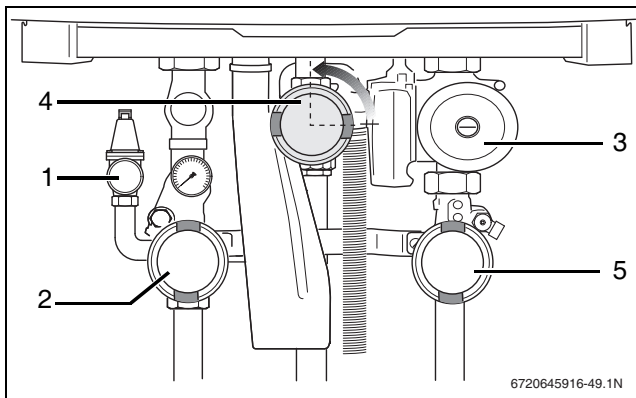

Fig. 52 Open the gas valve

- [1] pressure relief valve
- [2] supply water valve
- [3] pump
- [4] manual gas shutoff valve
- [5] return water valve

9.2 Fill the heating system

To ensure a trouble-free operation of the boiler, read the accompanying instructions about water quality, before filling the heating system.



NOTICE

- ▶ At initial start up, the boiler will start as soon as the system pressure exceeds 15 psi (1.0 bar).
- ▶ If the system pressure falls below 3 psi (0.2 bar) the boiler will stop and generate a fault code.

- ▶ Push and open the control panel cover.
- ▶ Turn the Space heating water temperature knob [8] and DHW temperature knob [10] counterclockwise to the "0" position.

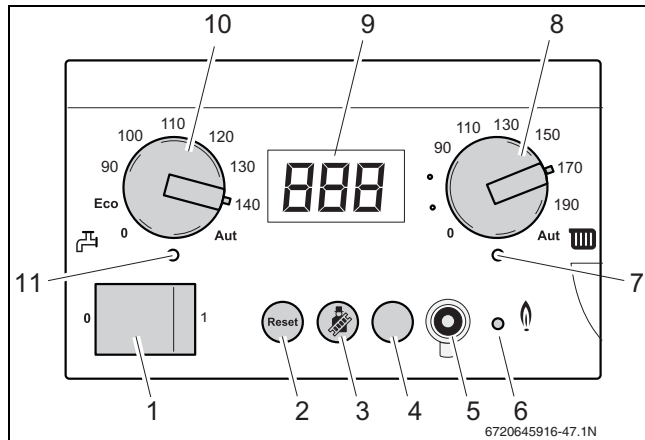

Fig. 53 BC10 basic controller

- ▶ Turn the vent key a quarter rotation to undo the boiler door lock (→ fig. 54, detailed picture). Push the fastener down (→ fig. 54, step 2) and open the boiler door.
- ▶ Remove the insulation cover of the pump group (→ fig. 54, step 4).

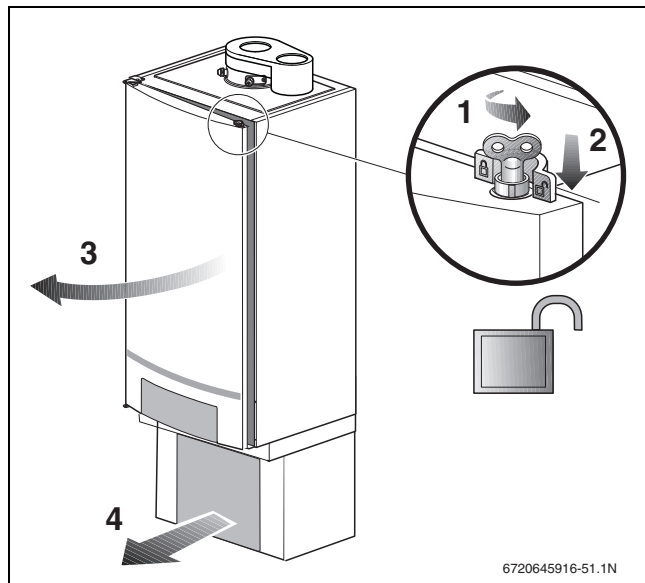

Fig. 54 Opening the boiler door

To purge the boiler, every radiator in the heating system must have a purge facility. In some situations it may even be necessary to provide extra purging facilities at certain locations. The boiler itself has an automatic air vent.

- ▶ Loosen the cap of the automatic air vent (→ fig. 55) by turning $\frac{1}{4}$ rotation counterclockwise.

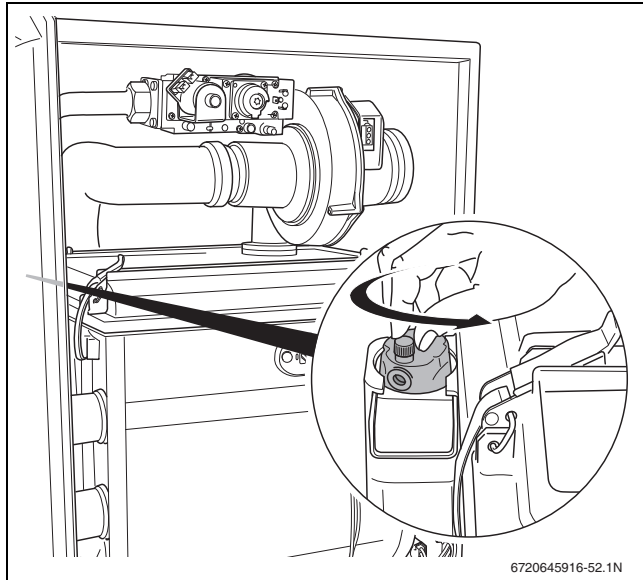

Fig. 55 Opening the automatic air vent

- ▶ Open the heating supply and return isolating valves on the pump group (→ fig. 56). The open position is parallel to the pipe.
- ▶ Fill the heating system to a pressure of about 20 psi (1.5 bar)

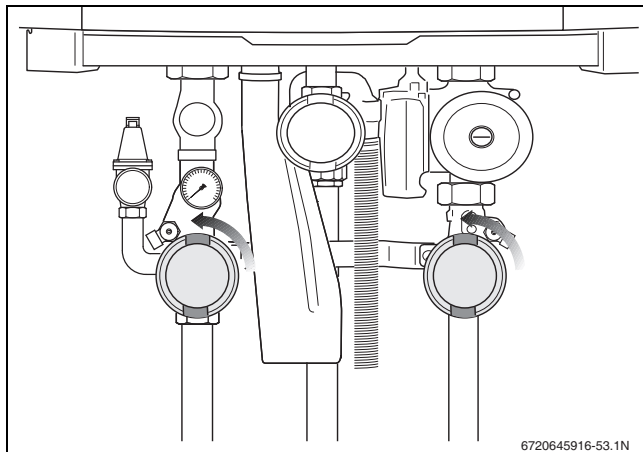

Fig. 56 Opening the isolating valves (here: open position)

- ▶ Read the pressure (PSI) from the pressure gauge on the pump group or on the control panel of the BC10 (→ fig. 57).

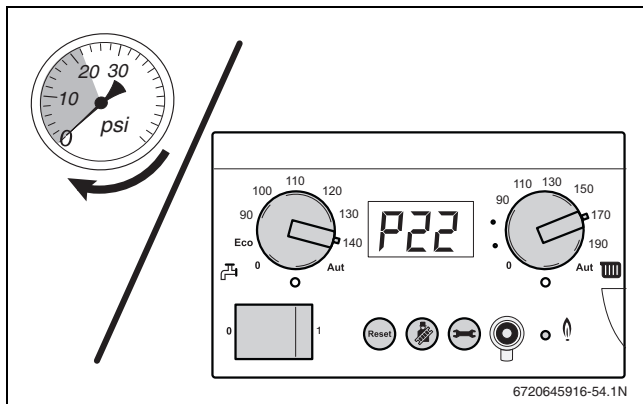

Fig. 57 Reading the pressure gauge

The pressure in the heating system, which is measured directly at the boiler, must be at least equal to the required pre-pressure of the expansion vessel plus 7 psi (0.5 bar). This minimum pressure must not be less than 12 psi (0.8 bar) (if the heating system is cold). The maximum pressure in the heating system, measured directly at the boiler, must not exceed 30 psi (2.6 bar) or 50 psi (3.5 bar) when the optional 50 psi (3.5 bar) pressure relief valve is used.

- ▶ Purge the heating system via the air vents on the heating bodies. Start at the lowest floor of the premises and then work your way up from floor to floor.

9.3 Fill the condensate trap with water

- ▶ Fill the condensate trap with water (→ fig. 58). For disconnecting the condensate trap (→ § 12.3.5, page 47).

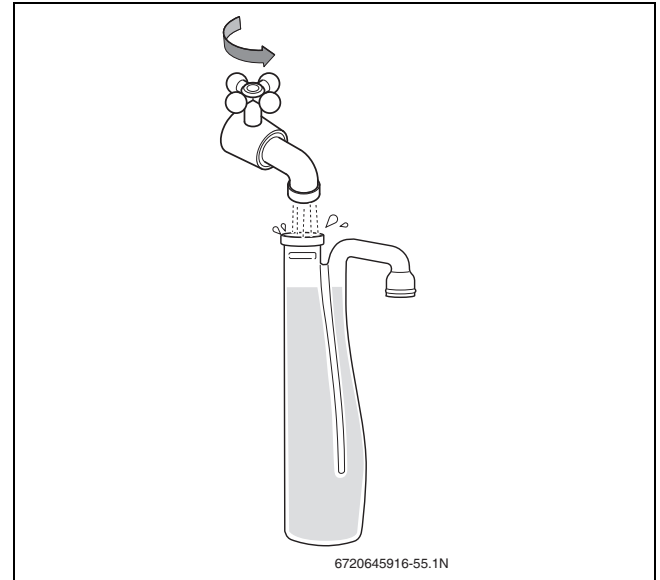

Fig. 58 Filling the condensate trap with water



WARNING:

Danger of fatal accident due to poisoning.

- ▶ If the condensate trap is not filled with water, flue gas can escape and put people's lives at risk.

9.4 Bleed the gas supply valve

- ▶ Close the gas valve (→ fig. 59).

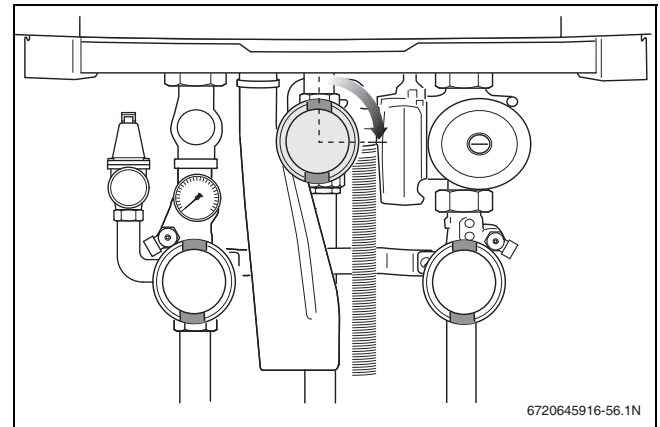

Fig. 59 Closing the gas valve

- ▶ Open the screw plug on the testing nipple of the gas supply pressure and for purging [1] by 2 turns and install a hose.

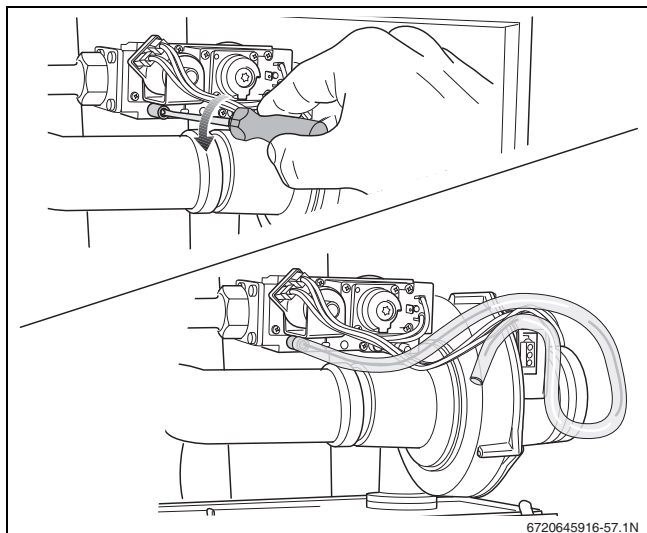

Fig. 60 Bleeding the gas flow pipe

- ▶ Slowly open the gas valve by pushing on the gas valve and turning it counterclockwise through ¼ rotation (→ fig. 61). The gas valve is open when it is in the vertical position.

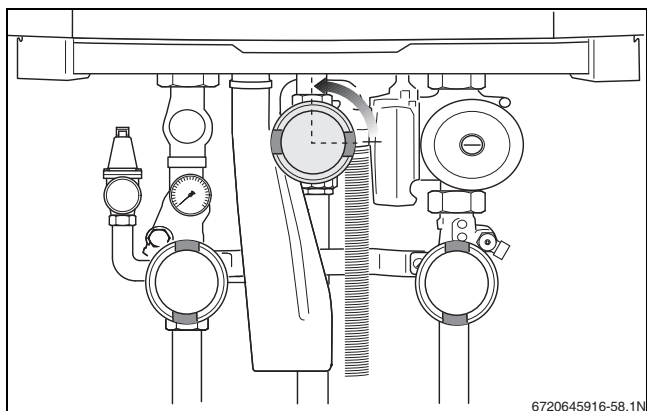

Fig. 61 Opening the gas valve

- ▶ Purge the gas supply into a well ventilated area.
- ▶ Close the gas shutoff valve when no more air is present (→ fig. 59).
- ▶ Remove the hose and tighten the screw plug on the testing nipple again.



NOTICE

- ▶ Test the tightness of the measuring nipple(s) used.

9.5 Check the air/flue gas connection

Check the following points:

- Is the prescribed flue gas system used (→ § 6.8, page 18)?
- Have the configuration instructions from the relevant flue gas system installation instructions been observed?

9.6 Checking the appliance configuration



NOTICE

The burner must only be put into use with the correct orifice (→ table 16).

- ▶ Consult the relevant gas utility company for the type of gas supply.
- ▶ Check that the actual gas supply is in accordance with the type of gas supply specified on the gas classification label (→ fig. 62).

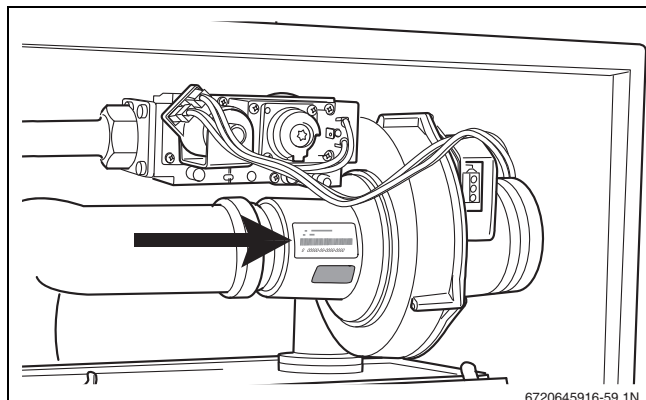

Fig. 62 Checking the gas classification label

Boiler	Type of gas supply	Altitude in ft. (m)	Gas orifice diameter in inch (mm)
GB162-80kW/ 100kW	Natural gas	0-4,000 (0-1,220)	0.331 (8.40)
	LPG	0-4,000 (0-1,220)	0.193 (4.70)

Table 16 Gas orifice diameter

9.7 Measure the gas inlet pressure (working pressure)

- ▶ Open at least 2 radiator valves, if present. Do not switch ON the boiler.
- ▶ Push on the control panel to open it.
- ▶ Switch OFF the power supply to the appliance.
- ▶ Close the gas valve in a clockwise direction (→ fig. 63).

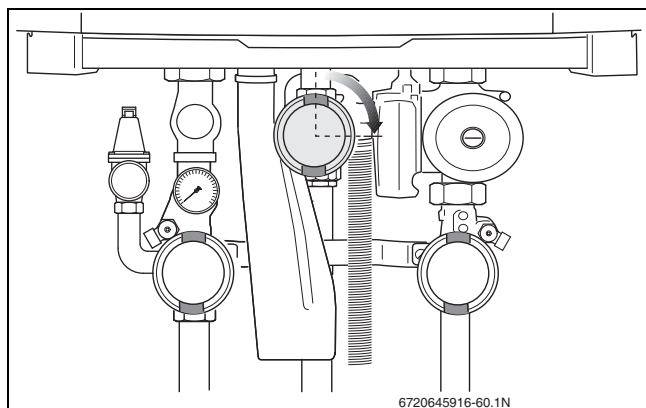

Fig. 63 Closing the gas valve

- ▶ Turn the vent key through a quarter rotation to undo the boiler door lock (→ fig. 54, page 34).
- ▶ Push the fastener down and open the boiler door.

- ▶ Open the screw plug on the testing nipple for the gas inlet pressure by 2 turns (→ fig. 64, [1]).

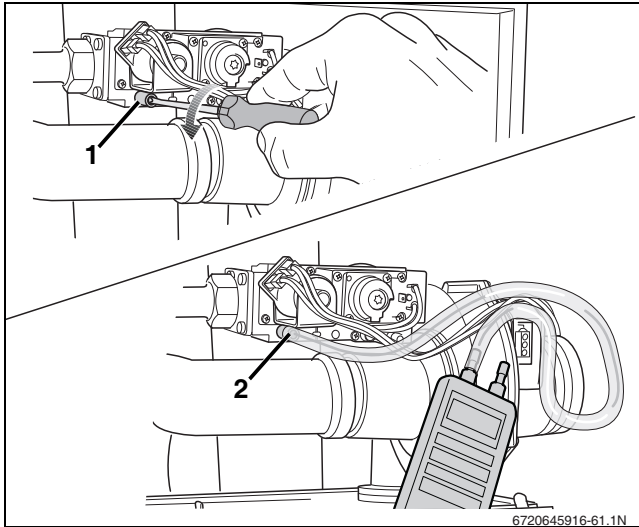

Fig. 64 Measuring the gas supply pressure

- ▶ Reset the digital pressure gauge to "0".



NOTICE

- ▶ Throughout the measuring operation, keep the digital pressure gauge in the same position (horizontal or vertical) in which it was reset to "0".

- ▶ Connect the pressure gauge connection tube to the positive port of the testing nipple (→ fig. 64, [2]).
- ▶ Slowly open the gas valve by pushing on the gas valve and turning it ¼ rotation in an counterclockwise direction (→ fig. 61, page 36). The gas valve is open when it is in the vertical position.
- ▶ Switch ON the appliance by pressing the main switch of the BC10 basic controller (→ fig. 65, [1]).
- ▶ Press and hold the "Chimney sweep" button (→ fig. 65, [3]) (approx. 2 seconds), until the dot in the right-hand bottom corner of the display (→ fig. 65, [9]) appears (→ table 12, page 31).
- ▶ After the LED "Burner operation" (→ fig. 65, [6]) has lit up wait for 1 minute until the boiler is burning at full load.
- ▶ Statically measure the gas supply pressure and enter it in the start-up report (→ § 15.1, page 57).

To obtain the best performance of the appliance, the gas supply pressure must be:

Statically measured ¹⁾ gas supply pressure	Natural gas inch W.C. (mbar)	LPG inch W.C. (mbar)
Min.	5 (12.4)	8 (19.9)
Nom.	8 (19.9)	11 (27.4)
Max.	10,5 (26.1)	13 (32.3)

Table 17 Gas supply pressure

1) Measured statically perpendicular to flow at full load.

- ▶ Press the "Service" button (→ fig. 65, [4]) repeatedly until the temperature reading is shown in the display.

- ▶ Press the "Chimney sweep" button (→ fig. 65, [3]) to clear the reading (→ table 12, page 31).

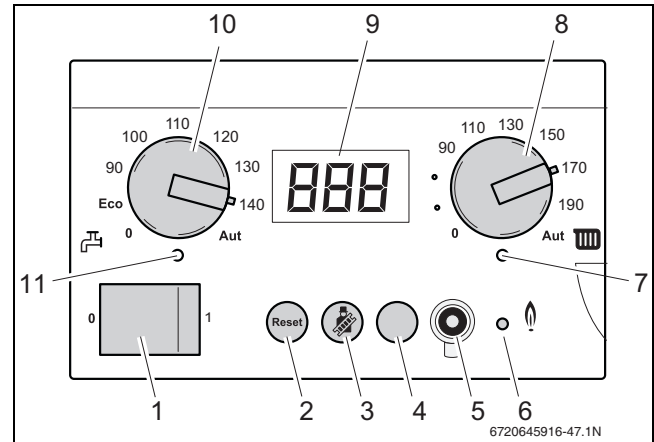

Fig. 65 BC10 basic controller

- [1] Main switch
- [2] "Reset" button
- [3] "Chimney sweep" button
- [4] "Service" button
- [5] Connection possibility for the diagnosis connector
- [6] LED "Burner operation"
- [7] LED "Central heat demand"
- [8] Space heating water temperature knob
- [9] Display
- [10] DHW temperature knob
- [11] LED "DHW demand"



WARNING:

A leaking testing nipple causes explosive fumes.



- ▶ Check the testing nipples used for leaks.
- ▶ Only use approved detection products to locate leaks.



NOTICE

- ▶ If the supply pressure is too low, check the gas supply pipe or contact the relevant gas utility company if the required supply pressure is not available.
- ▶ If the supply pressure is too high, a gas pressure regulator must be integrated upstream of the gas fitting. Contact the gas utility company.

- ▶ Close the gas valve.
- ▶ Remove the gauge-connection tube and tighten the screw plug on the testing nipple again.
- ▶ Open the gas valve again by pushing on the gas valve and turning it ¼ rotation in a counterclockwise direction.

- ▶ Switch OFF the heating system by pressing the main switch of the BC10 basic controller (→ fig. 65, [1]).
- ▶ Close the gas valve (→ fig. 63, page 36).
- ▶ Remove the measuring devices.
- ▶ Tighten the screw in the burner pressure measuring nipple.
- ▶ Slowly open the gas valve by pushing on the gas valve and turning it ¼ rotation in an counterclockwise direction (→ fig. 61).
- ▶ Switch ON the heating system by pressing the main switch of the BC10 basic controller (→ fig. 65, [1]).
- ▶ Press and hold the “Chimney sweep”  button (→ fig. 65, [3]) (approx. 2 seconds), until the dot in the right-hand bottom corner of the display appears (→ fig. 65, [9]) (→ table 12, page 31).
- ▶ After the LED “Burner operation” (→ fig. 65, [6]) has lit wait for 1 minute until the boiler is burning at full load.
- ▶ Press the “Chimney sweep”  button (→ fig. 65, [3]) to clear the reading (→ table 12, page 31).
- ▶ Check that the boiler performance is still at the required value (→ table 15, page 32).



9.9 Carry out a leakage test in operating conditions



WARNING:

Leaks may be caused to pipes and screw connections during commissioning and maintenance activities.

- ▶ Carry out a proper leak test.
- ▶ Only use approved leak detection agents for leak detection.

- ▶ Press and hold the “Chimney sweep”  button (→ fig. 65, [3]) (approx. 2 seconds), until the dot in the right-hand bottom corner of the display (→ fig. 65, [9]) appears (→ table 12, page 31).
- ▶ After the LED “Burner operation” (→ fig. 65, [6]) has lit up wait for 1 minute until the boiler is burning at full load.
- ▶ Use a foaming product to check all sealing locations in the total gas circuit of the burner while the burner is active.
- ▶ Press the “Chimney sweep”  button (→ fig. 65, [3]) to clear the reading (→ table 12, page 31).

9.10 Check and adjust the flue gases CO emissions

- ▶ Open at least 2 radiator valves, if present. Do not switch ON the boiler.
- ▶ Push on the control panel to open it.
- ▶ Switch OFF the appliance by pressing the main switch of the BC10 basic controller (→ fig. 65, [1]).
- ▶ Remove the cover from the flue gas measuring point (→ fig. 69, [1]).

- ▶ Connect the flue gas analyzer to the left-hand measuring point, insert it roughly 2" (→ fig. 69).

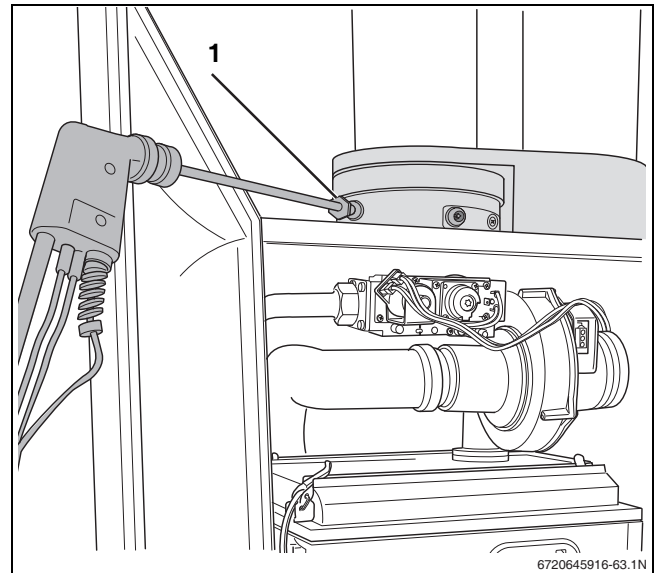



Fig. 69 Measuring the flue gases CO emissions

- ▶ Press and hold the  button (→ fig. 70, [3]) (approx. 2 seconds), until the dot in the right-hand bottom corner of the display (→ fig. 70, [9]) appears (→ table 12, page 31).
- ▶ After the “LED Burner operation” (→ fig. 70, [6]) has lit wait for 1 minute until the boiler is burning at full load.
- ▶ Measure in the flue gas measuring port the CO percentage. The CO values in air-free condition must be less than 400 ppm or 0.04 vol. %. Values of 400 ppm or more indicate an incorrect burner adjustment (→ § 9.8, page 38), a dirty gas burner or heat exchanger or burner faults.
- ▶ You must determine and remove the cause (→ chap. 12 “Maintenance”, page 44).
- ▶ Press the “Chimney sweep”  button (→ fig. 70, [3]) to clear the reading (→ table 12, page 31).
- ▶ Switch OFF the heating system by pressing the main switch of the BC10 basic controller (→ fig. 70, [1]).
- ▶ Remove the flue gas analyzer and fit the cover back onto the flue gas measuring point (→ fig. 70, [1]).
- ▶ Switch ON the heating system by pressing the main switch of the BC10 basic controller (→ fig. 70, [1]).
- ▶ Press on the control panel to close it.

9.11 Function test

- ▶ During initial start-up and annual inspection and/or needs-oriented servicing, make sure that all control, regulating and safety devices are in full working order and, if applicable, check them for correct adjustment.
- ▶ The gas and water circuits must be tested for leaks (→ § 9.1, page 34), (→ § 9.10, page 39).

9.12 Measure the ionization current

- ▶ Press on the control panel to open it.
- ▶ Open at least 2 radiator valves, if present. Do not switch ON the boiler.
- ▶ Switch OFF the appliance by pressing the main switch of the BC10 basic controller (→ fig. 70, [1]).

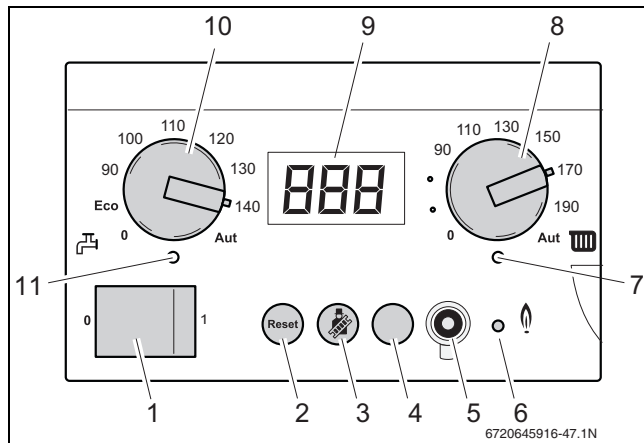

Fig. 70 BC10 basic controller

- ▶ Turn the vent key through a quarter turn to undo the boiler door lock (→ fig. 54, step 1).
- ▶ Push the fastener down (→ fig. 54, step 2) and open the boiler door.
- ▶ Undo the plug and socket connection of the monitoring cable (→ fig. 71).

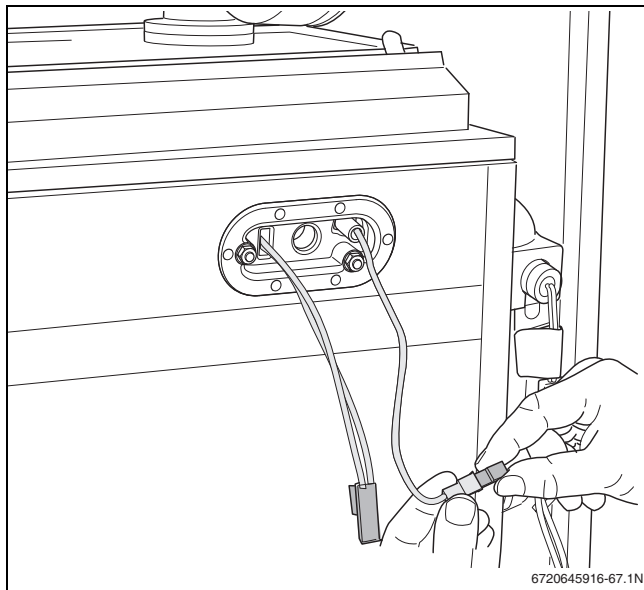

Fig. 71 Removing the ionization electrode plug and socket connection

- ▶ Connect the multi meter in series (→ fig. 72). Select the $\mu\text{A DC}$ range on the multi meter. The multi meter must have a resolution of at least $1 \mu\text{A}$.

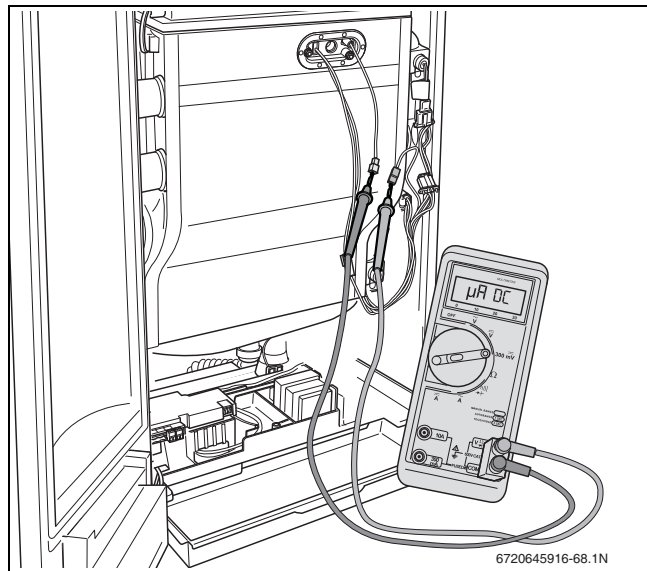

Fig. 72 Measuring the ionization current

- ▶ Switch ON the appliance by pressing the main switch of the BC10 basic controller (→ fig. 70, [1]).
- ▶ Activate the Service mode in accordance with the “Service mode” menu (→ table 13, page 31).
- ▶ Set the capacity to minimum (part load) according to the “Service mode” menu (→ table 13, page 31).
- ▶ After the LED Burner “operation” (→ fig. 70, [6]) has lit wait for 1 minute until the boiler is burning at part load.
- ▶ Measure the ionization current. The ionization current must be $> 5 \mu\text{A DC}$ at part load operation.
- ▶ Enter the result in the start-up report (→ § 15.1, page 57).
- ▶ If the result is not as it should be (→ § 9.10, page 39) or check the ionization electrode (→ § 12.3.4, page 46).
- ▶ Press and hold the “Chimney sweep” button (→ fig. 70, [3]) (approx. 2 seconds), until the dot in the right-hand bottom corner of the display (→ fig. 70, [9]) appears (→ table 12, page 31).
- ▶ Switch OFF the appliance by pressing the main switch of the BC10 basic controller (→ fig. 70, [1]).
- ▶ Remove the multi meter and reconnect the monitoring cable.
- ▶ Switch ON the appliance by pressing the main switch of the BC10 basic controller (→ fig. 70, [1]).
- ▶ Check that the boiler performance is still at the required value (→ table 13, page 31).

9.13 Test the Ignition Safety shut off device

- ▶ Switch OFF the appliance by pressing the main switch of the BC10 basic controller (→ fig. 70, [1]).
- ▶ Disconnect the plug and socket connection of the monitoring cable.
- ▶ Switch ON the appliance by pressing the main switch of the BC10 basic controller (→ fig. 70, [1]).
- ▶ Press the “Chimney Sweep” button and hold it (for approx. 2 seconds), until the display shows the decimal point.
- ▶ Check if the boiler does 1 start-up attempt and 3 restart attempts.

After each start-up attempt the boiler will signal a start-up failure. A “6A” code can be seen in the display.

After the last start-up attempt, the boiler will lock out. The “6A” code is blinking in the display.

- ▶ Connect the plug and socket connection of the monitoring cable.
- ▶ Press the “Reset” button.
- ▶ Check if the boiler starts-up.
- ▶ Press the “Chimney Sweep” button return to normal operating conditions.

9.14 Boiler settings

9.14.1 Set the heating capacity

- ▶ Set the required heating capacity on the BC10 according to the “Settings” menu. See table 18, when making these settings.

Display indication [%]	Rated heating capacity (±5%), based on natural gas (sea level)			
	GB162-80 kW		GB162-100 kW	
	kW	btu/h	kW	btu/h
L20	–	–	20.0	68,300
L30	24.3	78,300	29.9	97,900
L40	32.9	104,400	39.9	130,500
L50	41.5	130,500	49.8	163,200
L60	50.1	156,600	59.8	195,800
L70	58.7	182,700	69.7	228,400
L80	67.3	208,800	79.6	261,000
L90	75.9	234,900	89.6	293,700
L--	84.5	261,000	99.5	326,300

Table 18 Heating capacity (as a percentage) (0-4,000 ft.)

9.14.2 Set the space heating water temperature

- ▶ Set the upper space heating water temperature limit for heating mode with the “space heating water temperature” knob (→ fig. 73, [8]) (→ table 19). This limitation does not apply to DHW preparation.

Knob position	Explanation
0	No supply to appliance (e.g. only DHW mode)
86-190	The temperature (in °F) set on the BC10 cannot be changed with a room controller. The supply temperature does not rise above this set temperature. (maximum supply temperature set point 180 °F (82 °C)).
Aut	The temperature is determined automatically on the basis of the heating curve. If no room controller is connected, the maximum supply temperature is 180 °F (82 °C).

Table 19 Setting of the “space heating water temperature”

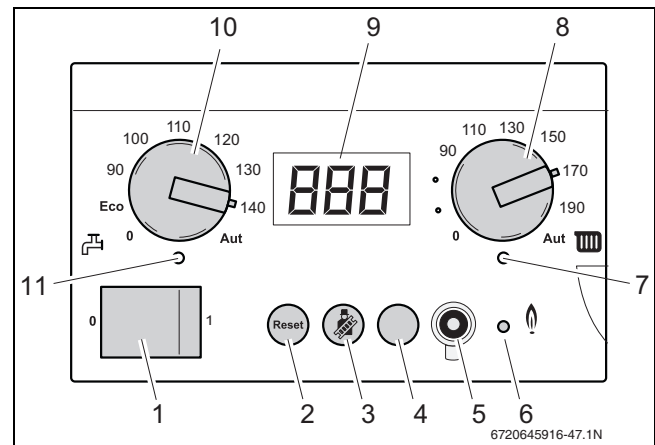

Fig. 73 BC10 basic controller

9.14.3 Set the pump run-over time

- ▶ Set the pump run-over time according to the “Settings” menu (→ table 15, page 32).

If the heating system is room temperature controlled, and not controlled parts of the heating system risk freeze damage (e.g. radiators in the garage), set the pump run-over time to 24 hours.

9.14.4 Switch DHW mode ON/OFF

- ▶ Set the DHW mode according to the “Settings” menu (→ table 15, page 32).

When DHW-mode is switched OFF (☐), the freeze protection for the hot water cylinder (if present) is switched OFF.

9.14.5 Set the DHW temperature

- ▶ Set the DHW temperature knob (→ fig. 73, [10]) to the required temperature of the hot water in the hot water cylinder (→ table 20).

Knob position	Explanation
0	DHW mode is OFF (only heating mode)
ECO	Economy mode. The DHW will only be reheated to 140 °F (60 °C), if the temperature has significantly fallen. This reduces the number of burner starts and saves energy. As a result the water may be a bit colder initially.
86-140	The temperature set on the BC10 is a temperature that cannot be changed using a RC thermostat.
Aut	The temperature is set on the thermostat (e. g. RC35). If no thermostat is connected, the maximum DHW temperature is 140 °F (60 °C).

Table 20 Setting of the “DHW temperature”

9.15 Final activities

9.15.1 Close the boiler door and the control panel

- ▶ Close the boiler door (→ fig. 74) and lock the fastener by turning the vent screw through ¼ rotation in a clockwise direction.
- ▶ Push on the control panel to close it.

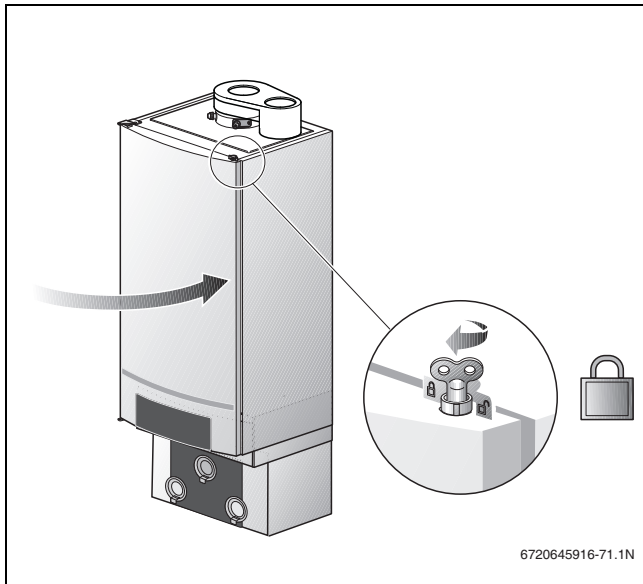

Fig. 74 Closing the boiler door

9.15.2 Hand over

- ▶ Hand over all relevant documentation to the end user and explain his/her responsibilities under the relevant national and regional regulations.
- ▶ Explain and demonstrate the start-up and shut down procedures.

10 Shutting down the system

CAUTION:
The heating system may freeze if it is not operational in times of freezing.

- ▶ Protect the heating system against freezing if there is a danger of frost affecting the system. Drain the heating system water from the lowest point of the heating system. The vent screw at the highest point of the heating system must then be open.

10.1 Shut down the appliance using the basic controller

Shut down your appliance by means of the Logamatic BC10 basic controller. When the system is shut down, the burner is automatically switched off.

Further information about the use of the BC10 basic controller is provided in chap. 8 "Operation", page 30.

- ▶ Push on the control panel to open it.
- ▶ Switch OFF the appliance by pressing the main switch of the BC10 (→ fig. 73, [1]).

- ▶ Close the main gas supply or the gas valve (→ fig. 75).

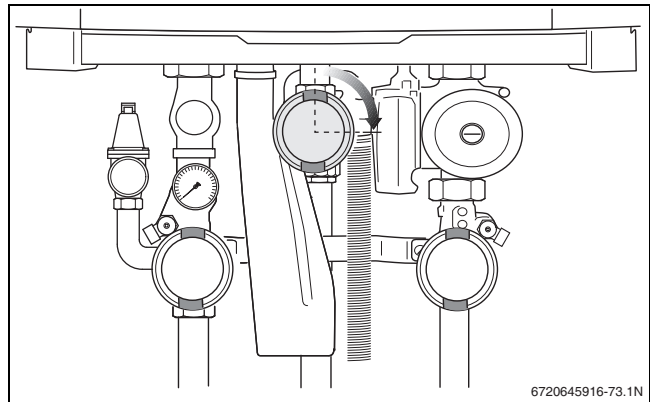

Fig. 75 Closing the gas valve

10.2 Shutting down the heating system if there is a risk of freezing (interruption of use)

If conditions are such that the heating system has to be shut down for a long period while there is a risk of freezing, the water must be drained from the heating system.

- ▶ Push on the control panel to open it.
- ▶ Switch off OFF appliance by pressing the main switch of the BC10 (→ fig. 73, [1]).
- ▶ Close the main gas supply or the gas valve (→ fig. 75).
- ▶ Drain the heating water at the lowest point of the heating system, using the drain cock or the heating body (→ fig. 76). The (automatic) air vent at the highest point of the heating system/radiator must be open.

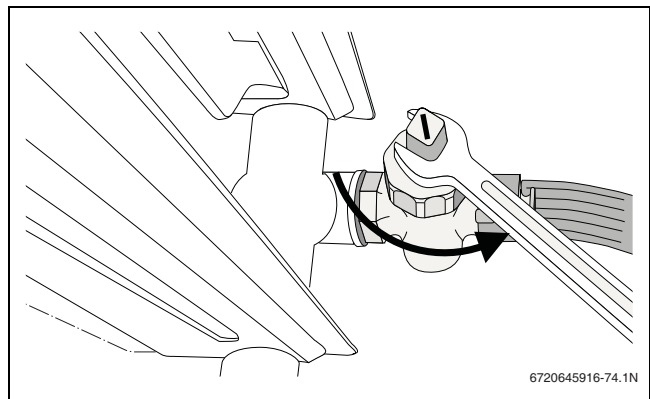

Fig. 76 Draining the heating system (example)

10.3 Shutting down the heating system in the event of an emergency

You must immediately close the main shutoff valve or gas shutoff valve and disconnect the power from the appliance.

- ▶ Close the main shutoff valve.

11 Inspection

Offer your customer an annual inspection and maintenance contract. The activities to be included in an annual inspection and maintenance contract can be found in the inspection (→ § 15.2, page 58) and service reports (→ § 15.3, page 58).



WARNING:

Do not use this boiler if any part has been under water.

- ▶ Immediately call a qualified service technician to inspect the boiler and to replace any part of the control system and any gas control which has been under water.



CAUTION:

Insufficient or improper cleaning and maintenance can cause damage to the installation.

- ▶ Inspect and clean the appliance once a year.
- ▶ Carry out maintenance as required. Immediately remedy faults. This will avoid further damage to the system!



CAUTION:

Risk of electric shock.

- ▶ Before opening the appliance:
- ▶ disconnect the appliance from the power supply using the appliance emergency OFF button or disconnect the relevant circuit breaker of the house from the power grid.
- ▶ Secure the appliance against accidental restarting.

- ▶ Periodically examine the venting systems and cleaning of the screens in the vent terminal.
- ▶ Also periodically inspect the low water cutoffs, including flushing of float types and clean the condensate collections and disposal system.

11.1 Prepare the appliance for inspection



INSTRUCTION FOR THE INSTALLER

- ▶ If gas pipes have to be disconnected from the gas burner fitting, the burner cover must only be opened by a specialized professional.

- ▶ Switch OFF the appliance by pressing the main switch of the BC10.
- ▶ Close the gas valve [1].

- ▶ Close the isolating valves [2].

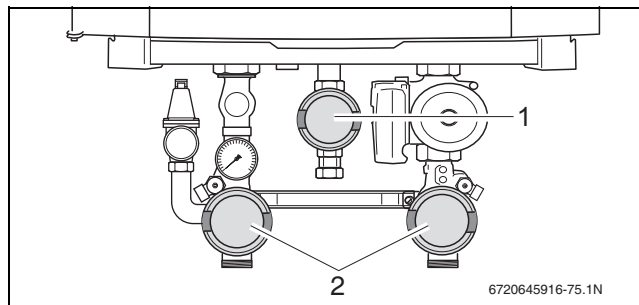

Fig. 77 Closing the valves (here: in closed position)

- ▶ Open the boiler door:
 - Turn the vent key through a quarter rotation to undo the boiler door lock (→ fig. 78, step 1).
 - Push the fastener down (→ fig. 78, step 2) and open the boiler door.



NOTICE

- ▶ If the boiler door cannot be opened completely, remove it (→ § 12.2, page 44).

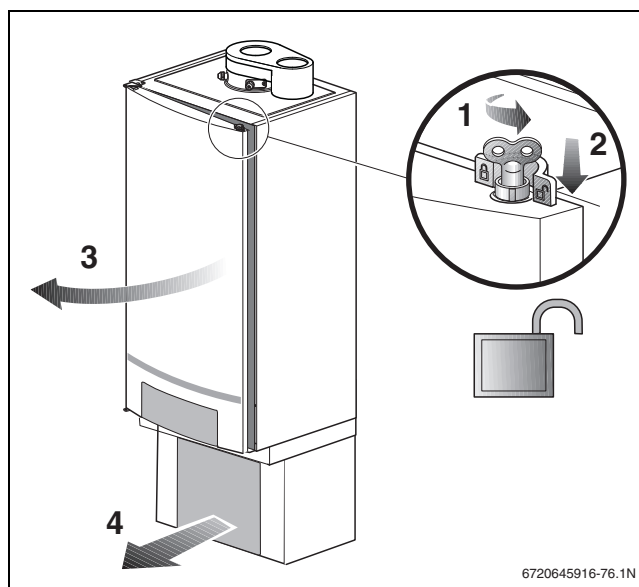

Fig. 78 Opening the boiler door

11.2 Carry out a visual check for general signs of corrosion

- ▶ Check all gas and water-bearing pipes for signs of corrosion and for leaks.
- ▶ Replace any pipes that are corroded.
- ▶ Carry out a visual inspection of the burner, heat exchanger, condensate trap, automatic air vent and all fittings in the boiler.

11.3 Gas valve leakage test

- ▶ Check the internal tightness of the gas fitting on the input side (with the boiler switched OFF) at a test pressure of 5.0" W.C. (12.4 mbar) for natural gas and 8.0" W.C. (19.9 mbar) for LPG.
- ▶ Check that the appliance is switched OFF.
- ▶ Open the screw plug on the testing nipple for the gas connection by 2 turns (→ fig. 79, [1]).

- ▶ Connect the pressure gauge tube to the testing nipple (→ fig. 79, [2]). The pressure drop allowed after 1 minute is max. 3.8" W.C. (10 mbar).
- ▶ If the pressure drop is higher, check all sealing locations of the gas fitting for leaks using a foaming product. Repeat the pressure test if no leaks are found. Replace the gas fitting if the pressure drop is higher than 3.8" W.C. (10 mbar) per minute again. See § 12.3.2 "Remove the burner cover with the fan and the gas valve", page 45 for instructions on how to remove.

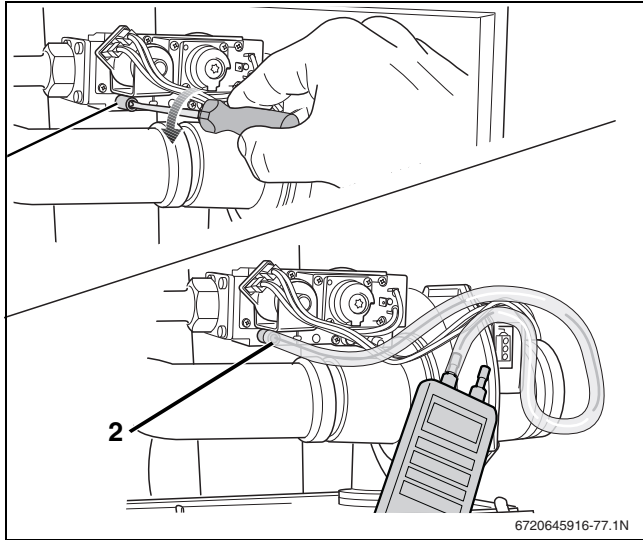

Fig. 79 Checking the gas fitting for internal tightness

11.4 Measure the ionization current

(→ § 9.12, page 40).

11.5 Measure the gas inlet pressure (working pressure)

(→ § 9.7, page 36).

11.6 Check and adjust the gas/air ratio

(→ § 9.8, page 38).

11.7 Carry out a leakage test in operating conditions

(→ § 9.9, page 39).

11.8 Measure the flue gases CO emissions

(→ § 9.10, page 39).

11.9 Fill the heating system

To ensure a trouble free operation of your boiler check the pH-value every year and correct it, if necessary. See accompanying manual about water quality for more information (→ § 9.2, page 34).

11.10 Check the air/flue gas connection

(→ § 9.5, page 36).

12 Maintenance



CAUTION:

Risk of electric shock.

- ▶ Before opening the appliance: disconnect the appliance from the power supply using the appliance emergency OFF button or disconnect the relevant circuit breaker of the house from the power grid.
- ▶ Secure the appliance against accidental restarting.



INSTRUCTION FOR THE INSTALLER

- ▶ Record the activities in the service report (→ § 15.3, page 58).



NOTICE

- ▶ There is no need to lubricate the combustion motor as it is permanently lubricated.

12.1 Prepare the heating system for maintenance



INSTRUCTION FOR THE INSTALLER

- ▶ If gas pipes have to be disconnected from the gas burner fitting, the burner cover must only be opened by a specialized professional.

- ▶ Switch OFF the appliance by pressing the main switch of the BC10.
- ▶ Close the gas valve [1].
- ▶ Close the isolating valves [2].

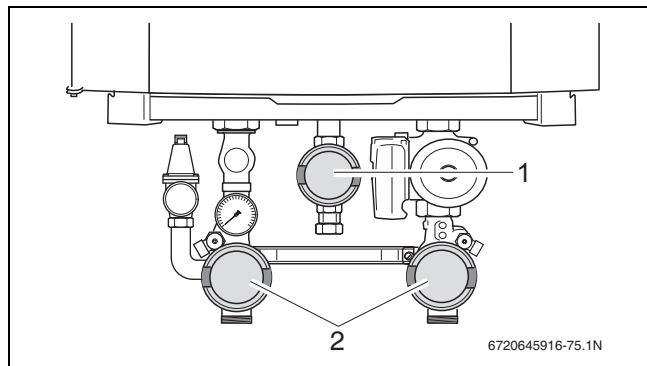

Fig. 80 Closing the valves (here: in closed position)

12.2 Remove the boiler door

- ▶ Unscrew the control panel from the boiler door and hang it on the boiler frame (→ § 13.1, page 49).
- ▶ Unscrew the bolt from left-hand top hinge of the boiler door and remove it together with the washer (→ fig. 81).
- ▶ Slightly lift the door and pull it from the hinge.
- ▶ Put the door upright in a safe position.



NOTICE

- ▶ The cover over the electrical connections does not have to be removed from the boiler.

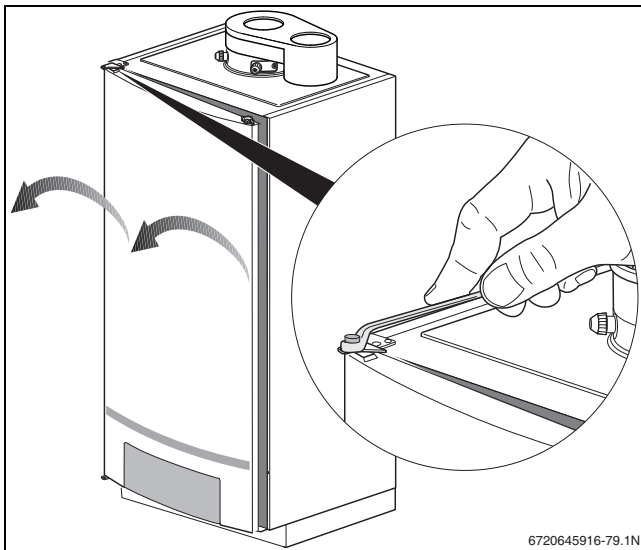

Fig. 81 Removing the boiler door

12.3 Clean the heat exchanger, burner and condensate trap

The boiler heat exchanger has a self-cleaning coating.



CAUTION:

To avoid a short circuit.

- ▶ Do not spray the cleaning agent onto the burner, the hot surface ignitor, the ionization electrode or other electric components.

12.3.1 Remove the gas valve

- ▶ Undo the gas fitting screw connection [1] and pull the 4 connectors [2] from the gas valve.

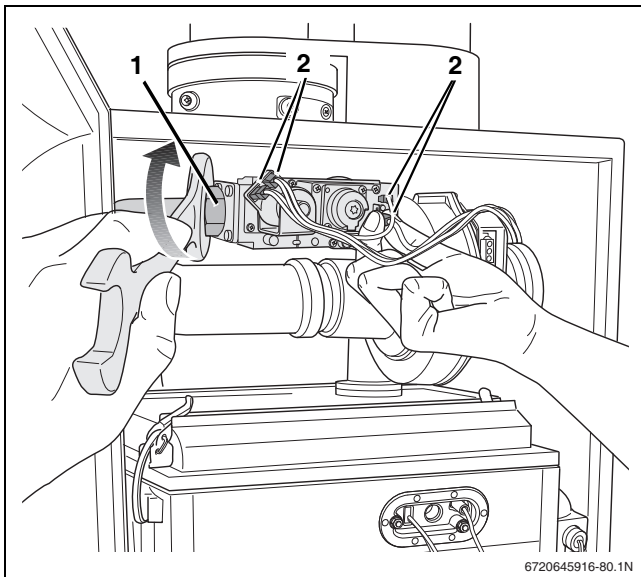

Fig. 82 Undoing the connections to the gas fitting

12.3.2 Remove the burner cover with the fan and the gas valve

- ▶ Pull the mains connector [1] from the fan.
- ▶ Pull the connector of the harness [2] from the fan while pushing on the connector lock to loosen it.

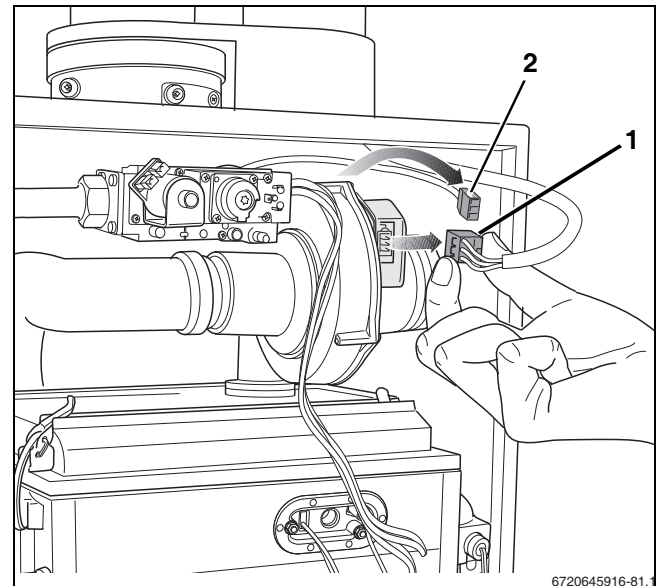

Fig. 83 Removing the connectors from the fan

- ▶ Pull the air suction tube from the fan (→ fig. 84).

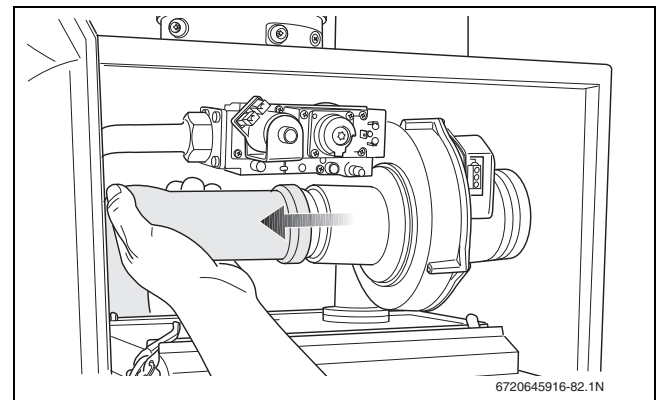

Fig. 84 Pulling the air suction tube from the fan

- ▶ Carefully open the 4 snap retaining clips on the burner cover (→ fig. 85). The retaining clips may be under tension.
- ▶ Remove the retaining clips.

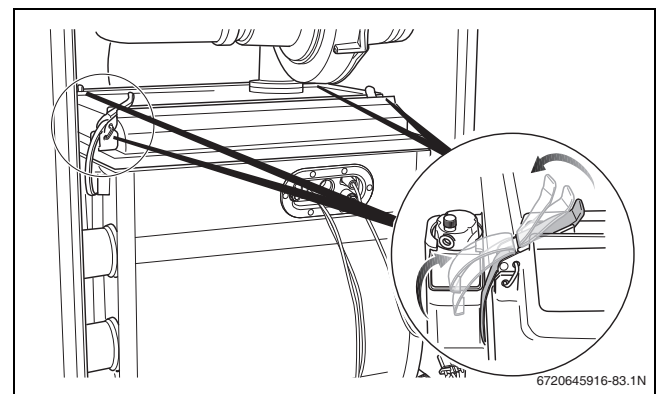

Fig. 85 Opening the retaining clips

- ▶ Remove the burner cover with the gas/air unit (→ fig. 86).

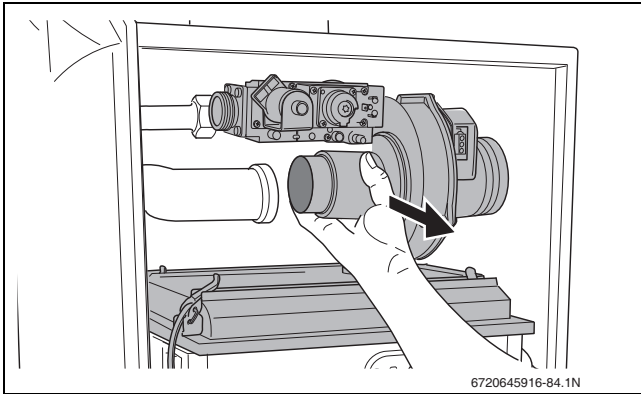

Fig. 86 Removing the burner cover with the gas/air unit

12.3.3 Remove the burner and the burner seal

- ▶ Remove the burner seal [1] and replace it if necessary.
- ▶ Remove the burner plate [2] and clean it on all sides using compressed air or a soft brush.

When re-installing the burner plate make sure that the notch is on the right-hand side (→ fig. 87, detailed picture).

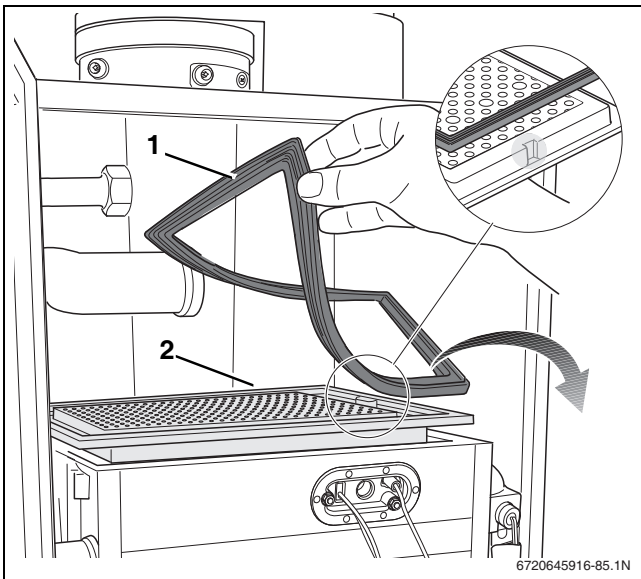

Fig. 87 Removing the burner plate and the burner seal

12.3.4 Checking ignition unit

DANGER:

- ▶ Close the gas valve prior to working on components in contact with gas.
- ▶ Check for gas tightness after carrying out work on components in contact with gas.

NOTICE

The glow ignitor is fragile.

- ▶ Handle with care.

NOTICE

If the seat of the cover plate leaks, the seal can burn away.

- ▶ Check the cover plate for tightness.

NOTICE

Since the effectiveness of the seals in the ignition unit is reduced, the gas condensing boiler may become damaged.

- ▶ The rubber seal (→ fig. 89, [3]) and the cover plate with seal (→ fig. 89, [4]) need to be replaced every 4 years.

- ▶ Check the individual components of the ignition unit (→ fig. 89) for wear or contamination (→ fig. 88).
- ▶ If required, replace the ionization electrode and/or glow ignitor.
- ▶ After checking or replacing the ionization electrode and/or the glow ignitor fit a new cover plate and rubber seal.

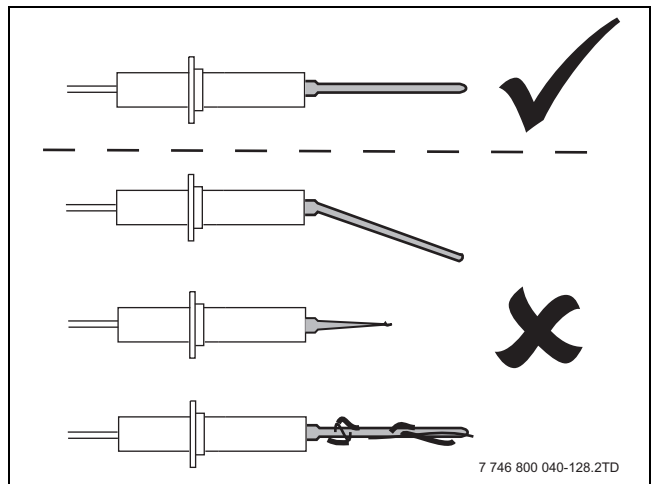

Fig. 88 Checking the ionization electrode

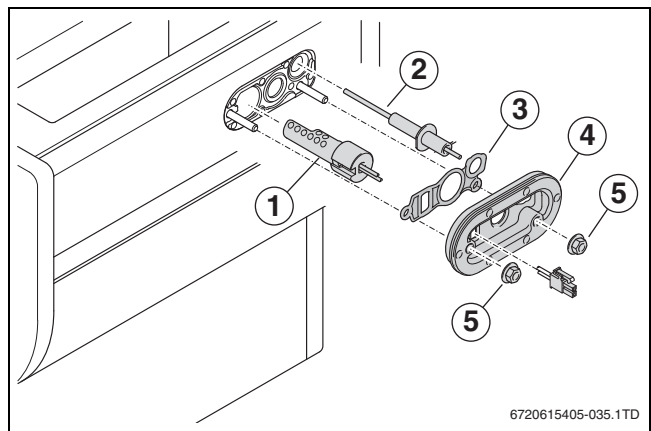

Fig. 89 Replacing the ignition unit

- [1] glow ignitor
- [2] ionization electrode
- [3] Rubber seal
- [4] Cover plate with seal
- [5] Nut

12.3.5 Disconnect the condensate trap

- ▶ Disconnect the condensate trap hose [3] and the rubber sleeve [2] from the condensate trap [1].
- ▶ Turn the condensate trap a quarter rotation counterclockwise (→ fig. 90).

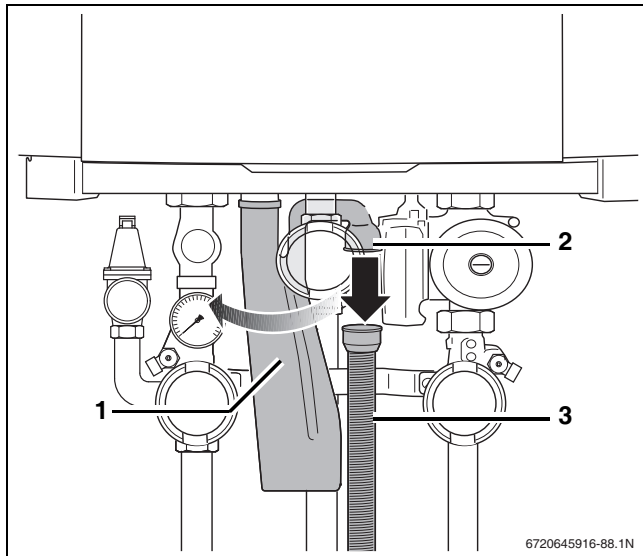

Fig. 90 Disconnecting the condensate trap hose

- [1] Condensate trap
- [2] Rubber sleeve
- [3] Condensate trap hose

- ▶ Disconnect the condensate trap from the coupling and remove it [1].

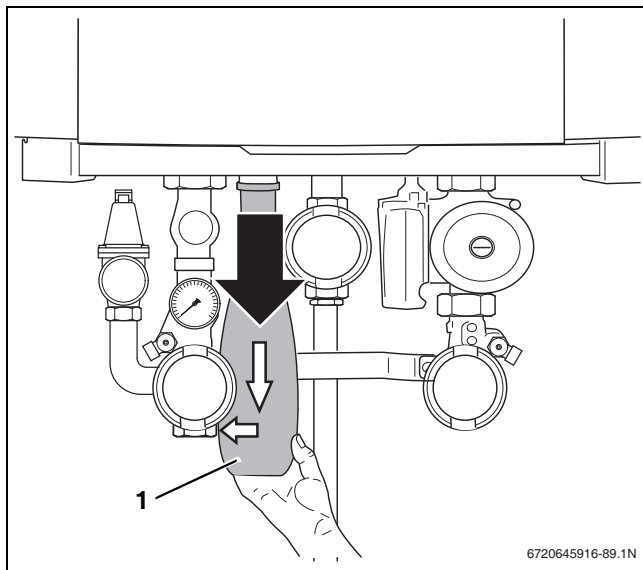

Fig. 91 Disconnecting the condensate trap

- ▶ Rinse the condensate trap to clean it.
- ▶ Fill the condensate trap with water and reinstall it.



NOTICE

- ▶ The condensate trap has a bayonet connector. After inserting it, the condensate trap must be turned ¼ rotation clockwise to click into position.

12.3.6 Remove the condensate collector

- ▶ Disconnect the flexible condensate drain hose and bend it backwards (→ fig. 92).

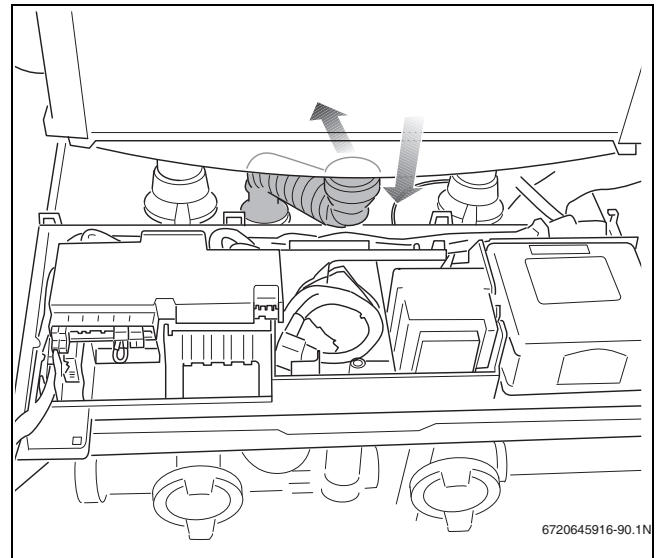

Fig. 92 Removing the condensate trap hose

- ▶ Open the 2 clamps on the right and left at the bottom of the condensate collector [1].
- ▶ Pull the condensate collector down [step 1] and remove it by pulling it towards you [step 2].

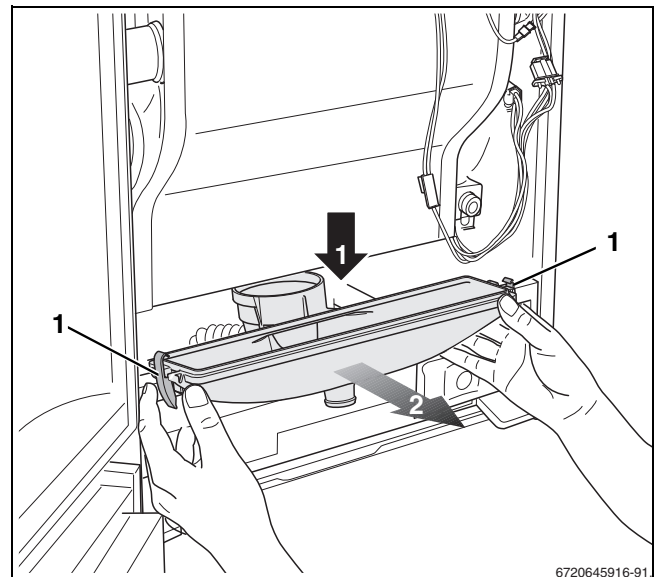

Fig. 93 Removing the condensate collector

- ▶ Check the condensate collector for damage and replace it if required.

- ▶ Clean the condensate collector mechanically (using compressed air or a soft brush) and rinse it with clean water (→ fig. 94).

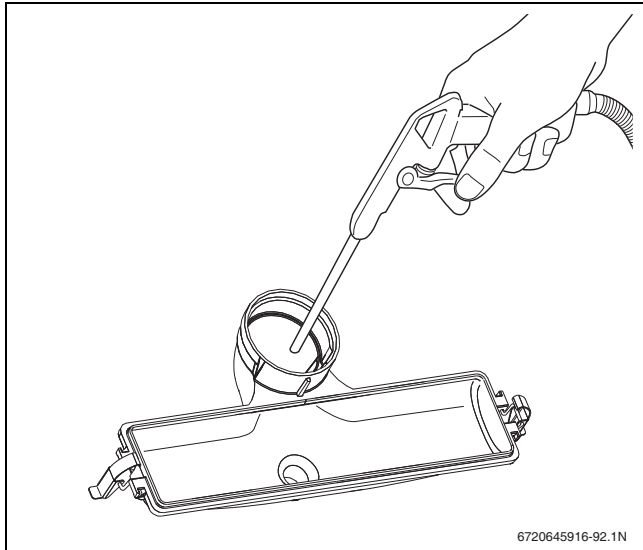

Fig. 94 Cleaning the condensate collector

12.3.7 Clean the heat exchanger

CAUTION:
Incorrect handling can damage the boiler.

- ▶ Do not use metal brushes or similar hard cleaning tools.
- ▶ Handle the glow ignitor with care, it is made from fragile ceramic material.
- ▶ Cover the boiler interior using a blanket or a cover to prevent dirt entering the boiler.

WARNING:
If the condensate collector is installed incorrectly.

- ▶ Flue gas or condensate may leak

- ▶ Clean the heat exchanger with compressed air or a soft brush (→ fig. 95).

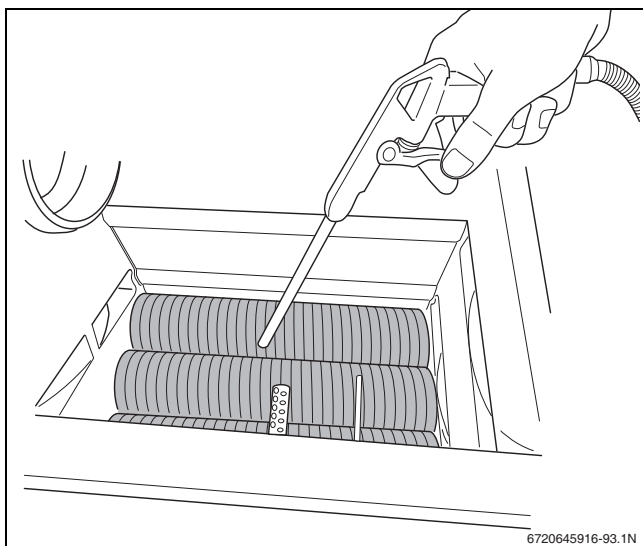

Fig. 95 Cleaning the heat exchanger

- ▶ Refit the condensate collector and make sure that the 2 retaining clips close smoothly. If this is not the case, the seal between the condensate collector and the flue pipe at the rear side of the heat exchanger may be leaking.
- ▶ Connect the flexible condensate drain hose to the condensate collector.
- ▶ Re-install the condensate trap.
- ▶ Rinse the heat exchanger with clean water.
- ▶ Reassemble all boiler components in reverse order:
 - Burner with burner seal,
 - Burner cover with fan and gas valve,
 - Gas valve,
 - Glow ignitor and ionization electrode.
- ▶ Start up the boiler (→ chap. 9 "Start-up procedure", page 33).

12.4 Check and adjust the gas/air ratio (flue gases CO₂ emissions)

(→ § 9.10, page 39)

12.5 Function check

- ▶ Slowly open the gas valve by pushing on the gas valve and turning it ¼ rotation in an counterclockwise direction.
- ▶ Switch ON the appliance by pressing the main switch on the BC10 basic controller [1]).
- ▶ Set the space heating water temperature knob [8] and the DHW temperature knob [10] to the maximum temperatures.
- ▶ Enter a heat demand via the control unit and check that the boiler starts the heating mode.
- ▶ Open a hot water tap and check that the boiler starts the DHW mode.
- ▶ Set the space heating water temperature knob [8] and the DHW temperature knob [10] to the required temperatures.

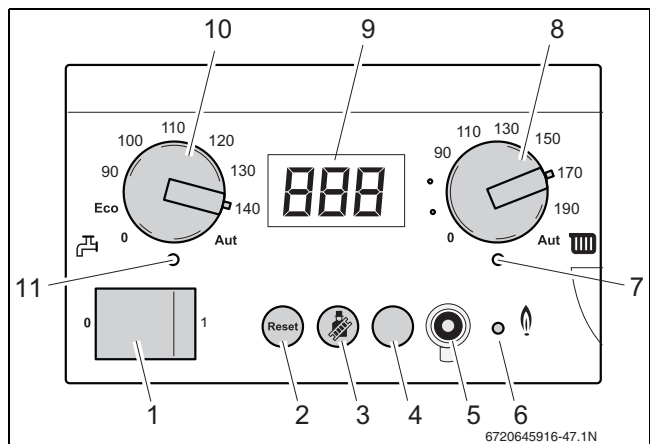

Fig. 96 BC10 basic controller

13 Display information

13.1 Removing the control panel

To make it easier to use the buttons on the control panel when the boiler door is open and to make it easier to read the values in the display, you can disassemble the control panel from the boiler door and hang it from the boiler frame.

- ▶ Open the boiler door.
- ▶ Loosen the 2 screws of the control panel at the rear side of the boiler door [1].

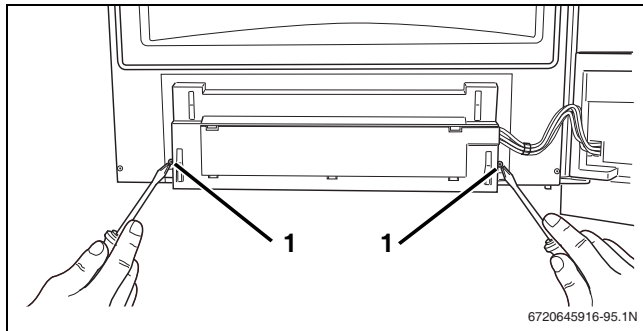

Fig. 97 Loosening the screws

- ▶ Loosen the cable tie [1].
- ▶ Remove the control panel (→ fig. 98).

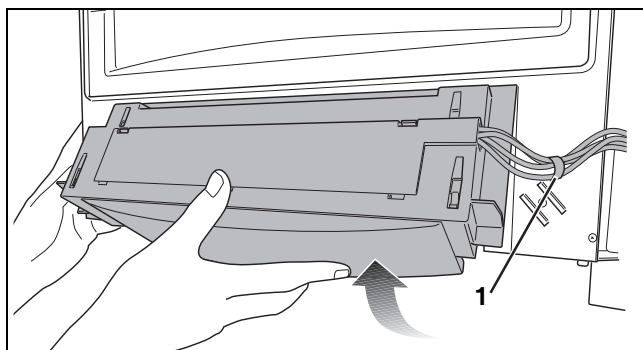

Fig. 98 Removing the control panel

13.4 BC10 Display settings

Display readings				
Display setting	Meaning of display setting	Unit	Range	Factory-adjusted setting
L 99	Sea level (0-4,000 ft.): configured target load (GB162-80 kW)	%	L 25 - L 99 / L -- 100%	L --
	Sea level (0-4,000 ft.): configured target load (GB162-100 kW)	%	L 20 - L 99 / L -- 100%	L --
F 5	Configured target value of the pump run-over time. NOTE: Do not set the pump run-over time to less than F 5 (= 5 minutes).	min.	F 00 - F 60 / F 1d 100%	F 5
E 1	DHW flow operating condition setting. NOTE: If the setting E 0 is displayed, the frost protection of the DHW flow has also been switched off.	-	E 0 "Off" / E 1 "On"	E 1

Table 22 BC10 Display settings

- ▶ Use the 2 hooks to hang the control panel from the boiler (→ fig. 99).

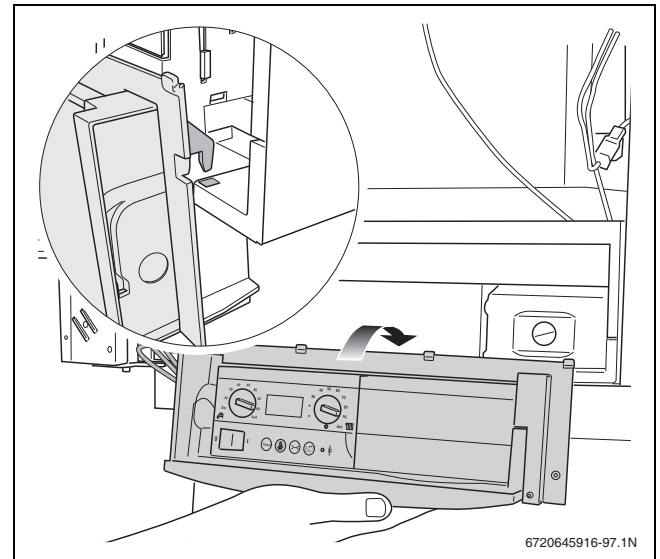

Fig. 99 Hanging the control panel from the boiler frame

13.2 Replacing the control panel

- ▶ Take the control panel from the boiler frame.
- ▶ Install the control panel in the boiler door by following the procedure in § 13.1 "Removing the control panel", page 49 in reverse order.

13.3 BC10 Display readings

Display readings			
Display reading	Key to display reading	Unit	Range
75	Current space heating water temperature	°F	0 - 190
P22	Current system pressure	psi	P00 - P58

Table 21 BC10 Display readings

13.5 BC10 Display codes

The following table contains all codes that can show on the BC10 display. To show the current display code and/or sub code, press the "Service"  button repeatedly.

There are 3 main code groups:

- Operating codes - this code gives the status of the boiler. No action is necessary.

- Locking faults - the boiler resumes normal operation when the fault has cleared.
- Blocking faults - the boiler is locked and will only restart after a manual reset. The pump will operate continuously for frost protection.

If a blinking code is displayed together with other codes, all displayed codes will blink. A locking code will always show on the first screen of the BC10.





























Display codes			
Main display code	Sub display code	Key to display code	Other effects
		Operating phase: Communication test while starting up. This display code flashes 5 times within 5 seconds while starting up to indicate that the communication between the UBA 3 and the BC10 basic controller is being tested. If a new UBA 3 or a new KIM was fitted, this code will flash for max. 10 seconds.	
		Blocking fault: If this code continues to flash on the display, there is a fault in the communication between the UBA 3 and the BC10 basic controller.	No heating operation and no DHW.
	 ¹⁾	Operating phase: The boiler is in flue gas test or service mode.	
	 ¹⁾	Operating phase: The boiler is in heating mode	
	 ²⁾	Operating phase: The boiler is in manual operation mode.	The room temperature is too high.
	 ¹⁾	Operating phase: The boiler is in DHW mode.	
	 ¹⁾	Operating phase: Pump run-over time via the external hot water cylinder 130 seconds at minimum speed. The LED "Burner operation" is off.	
	 ¹⁾	Operating phase: The switch optimization program is activated. This program is activated if there has been a DHW request from an RC regulator more frequently than once every 10 minutes. This means that the boiler cannot be restarted until at least 10 minutes have elapsed since initial burner start-up.	The room temperature is not possibly reached.
	 ¹⁾	Operating phase: The boiler cannot start up temporarily after a DHW request has ended.	
	 ¹⁾	Pre-operative phase: The boiler prepares for a burner start-up whenever a heat demand or a DHW request arises.	
	 ¹⁾	Readiness for operation: The boiler is in standby mode. There is a current heat demand, but too much energy has been supplied.	
	 ¹⁾	Readiness for operation: The boiler is in standby mode. There is no current heat demand.	
	 ¹⁾	Ignition phase: The gas valve is activated.	
	 ¹⁾	Start-up phase: The boiler starts up after activation of the mains power supply or completion of a system reset. This code is displayed for a maximum of 4 minutes.	
	 ¹⁾	Operating phase: The flow temperature sensor has detected that the current flow temperature is higher than the flow temperature setting on the BC10, or that it is higher than the flow temperature calculated according to the heating curve, or that it is higher than the flow temperature calculated for the DHW mode.	The room temperature is not possibly reached.

Table 23 Display codes

Display codes			
Main display code	Sub display code	Key to display code	Other effects
04	276	Locking fault: The flow temperature sensor has measured a current flow temperature higher than 203 °F (95 °C).	The room temperature is not possibly reached.
04	277	Locking fault: The safety temperature sensor has measured a current flow temperature higher than 203 °F (95 °C).	The room temperature is not possibly reached.
04	285	Locking fault: The return temperature sensor has measured a current return temperature higher than 203 °F (95 °C).	The room temperature is not possibly reached.
1A	316	Blocking fault: The flue gas sensor temperature is too high.	No heating operation and no DHW.
1L	211	Locking fault: There is no connection between contacts 78 and 50 of the UBA 3 installation base.	No heating operation and no DHW.
1U	317	Blocking fault: The flue gas sensor contacts have shorted.	No heating operation and no DHW.
1Y	318	Blocking fault: The flue gas sensor contacts are open.	No heating operation and no DHW.
2E	207	Locking fault: The system pressure is too low (less than 3 psi [0.2 bar]).	No heating operation and no DHW.
2F	260	Locking fault: The flow temperature sensor has not, after burner start-up, detected any temperature increase in the heating systems water.	
2P	271	Locking fault: The heating water temperature difference, measured between the flow temperature sensor and the safety temperature sensor, is too high.	
2P	212	Locking fault: The flow temperature sensor has measured a heating water temperature increase of over 40 °F/s (5 °C/s).	
2U	213	Locking fault: The temperature difference measured between the flow temperature sensor and the return temperature sensor, is more than 122 °F (50 °C).	
2Y	281	Locking fault: The pump has stopped or is running without water.	
2Y	282	Locking fault: No feedback from the pump.	
3A	264	Locking fault: The tachometer signal from the fan has failed during the operating phase.	
3C	217	Blocking fault: No current of air after a certain time.	No heating operation and no DHW.
3F	273	Operating phase: The appliance has been switched off for a couple of seconds, because it had been running without any interruption for 24 hours. This is a safety check.	
3L	214	Blocking fault: The tachometer signal from the fan is not present during the pre-operative or operating phase.	No heating operation and no DHW.
3P	216	Blocking fault: The fan is running too slowly.	No heating operation and no DHW.
3Y	215	Blocking fault: The fan is running too fast.	No heating operation and no DHW.
4A	218	Blocking fault: The flow temperature sensor has detected a flow temperature of over 221 °F (105 °C)	No heating operation and no DHW.

Table 23 Display codes

















































Display codes			
Main display code	Sub display code	Key to display code	Other effects
		Blocking fault: There is no bridging cable between contacts 22 and 24 of the UBA 3 contact strip.	No heating operation and no DHW.
		Blocking fault: The sensor test has failed.	No heating operation and no DHW.
		Blocking fault: The safety temperature sensor has detected a flow temperature of over 266 °F (130 °C).	No heating operation and no DHW.
		Blocking fault: The contacts for the safety temperature sensor have shorted or the safety temperature sensor has detected a flow temperature of over 266 °F (130 °C).	No heating operation and no DHW.
		Blocking fault: The contacts for the safety temperature sensor have been interrupted.	No heating operation and no DHW.
		Blocking fault: The contacts for the safety temperature sensor have shorted.	No heating operation and no DHW.
		Blocking fault: The contacts for the safety temperature sensor have been interrupted.	No heating operation and no DHW.
		Operating phase: Component test phase.	
		Locking fault: The system has detected an insufficient ionization current during the ignition phase.	
		Blocking fault: The system has detected an insufficient ionization current after 4 start-up attempts.	No heating operation and no DHW.
		Blocking fault: The system has detected an ionization current before burner start-up.	No heating operation and no DHW.
		Blocking fault: An ionization current has been measured after the burner shut down.	No heating operation and no DHW.
		Blocking fault: The system has detected an insufficient ionization current during the operating phase.	
		Blocking fault: The system has detected an insufficient ionization current during the operating phase.	No heating operation and no DHW.
		Blocking fault: The ionization current is too high.	No heating operation and no DHW.
		Blocking fault: The power supply was interrupted during a locking fault        	No heating operation and no DHW.
		Blocking fault: There was a momentary interruption of power.	No heating operation and no DHW.
		Blocking fault: The UBA 3 is defect.	No heating operation and no DHW.
		Blocking fault: The UBA 3 is defect.	
	 ¹⁾	Operating phase: The external switch contact is open.	No heating operation.
		Start-up phase: The boiler starts up after activation of the mains power supply or completion of a system reset. This code is displayed for a maximum of 4 minutes.	

Table 23 Display codes

Display codes			
Main display code	Sub display code	Key to display code	Other effects
9A	235	Blocking fault: The UBA 3 or the KIM is defective.	No heating operation and no DHW.
9H	237	Blocking fault: The UBA 3 or the KIM is defective.	No heating operation and no DHW.
9H	272	Blocking fault: The UBA 3 or the KIM is defective.	No heating operation and no DHW.
9L	234	Blocking fault: The contacts for the gas valve have been broken.	No heating operation and no DHW.
9L	238	Blocking fault: The UBA 3 or the KIM is defective.	
9P	239	Blocking fault: The UBA 3 or the KIM is defective.	No heating operation and no DHW.
9U	233	Blocking fault: The UBA 3 or the KIM is defective.	No heating operation and no DHW.
RD 1	B00	Locking fault: The contacts to the outdoor-temperature sensor have shorted or are interrupted, the sensor has been connected incorrectly or is defective.	Minimum outdoor temperature is assumed.
RD 1	B08	Locking fault: The contacts to the DHW temperature sensor have shorted or are interrupted, the sensor has been connected incorrectly or is defective.	No DHW is heated any more.
RD 1	B09	Locking fault: The contacts to DHW temperature sensor to have shorted or are interrupted, the sensor has been connected incorrectly or is defective.	No DHW is heated any more.
RD 1	B10	Locking fault: The boiler water does not warm up. Sensor lead broken or shorted, sensor connected incorrectly or defective, filling pump connected incorrectly or defective, permanent tapping or leak.	No DHW available, but there is heating operation. The DHW priority is cancelled when the fault message appears. Switch the boiler off and on to reset the boiler.
RD 1	B11	Locking fault: Thermal disinfection has failed. Outlet flow during disinfection period too high, sensor lead broken or shorted, sensor connected incorrectly or defective, filling pump defective.	Thermal disinfection was interrupted.
RD 1	B16	Locking fault: No connection to EMS. EMS bus system is overloaded, UBA 3/MC10 is defective.	The boiler no longer receives a heat demand. The heating system does not heat any longer.
RD 1	B28	Locking fault: Water pressure sensor generates a fault code. The digital water pressure sensor is defective.	No heating operation and no DHW.
RD2	B16	Locking fault: No communication with BC10. Contact problem at BC10 or BC10 is defective.	BC10 settings are no longer taken over by RCxx devices.
A 12	B15	Locking fault: The contacts to the switch sensor have shorted or are interrupted, the sensor has been connected incorrectly or is defective.	The water flow to the downstream heating circuits may be faulty now they can no longer be provided with the required heat capacity.
A 12	B16	Locking fault: WM10 not available or no communication. WM10 or bus circuit connected incorrectly or defective, WM10 is not recognized by the RC-thermostat.	Heating circuit pump 1 is activated continuously.
A 18	B25	Locking fault: Conflicting addresses. Both RC20 and RC35 are registered as Master.	Both RC35 and RC20 activate heating circuit 1 and DHW. Depending on the heating programs set and the required room temperatures, the heating system can no longer work correctly. DHW mode does not work well.

Table 23 Display codes

Display codes			
Main display code	Sub display code	Key to display code	Other effects
		Locking fault: RC20-HK1 temperature sensor. The integrated temperature sensor of the remote control (control unit) of heating circuit 1 is defective.	Since there is no actual room temperature information, room influence and optimization of the switch times do not work. The EMS works on the basis of the values last set on the remote control.
		Locking fault: The contacts to the heating circuit flow sensor have shorted or are interrupted, the sensor has been connected incorrectly or is defective.	Since there is no actual room temperature information, room influence and optimization of the switch times do not work.
		Locking fault: The contacts to the heating circuit flow sensor have shorted or are interrupted, the sensor has been connected incorrectly or is defective.	Heating circuit pump 2 is activated depending on the preset value. The power to the mixer is switched off and the mixer stays in the state it was last put in (can be adjusted manually).
		Locking fault: MM10 not available or no communication. The heating circuit addresses on the MM10 and the RC35 do not match up, the MM10 or the bus circuit is connected incorrectly or is defective, MM10 is not recognized by the RC35.	Heating circuit 2 cannot be operated correctly. MM10 and the mixer automatically goes into emergency operation. Heating circuit pump 2 is activated continuously. Monitor data in the RC35 is invalid.
		Blocking fault: The return temperature sensor has measured a return temperature higher than 221 °F (105 °C)	No heating operation and no DHW.
		Blocking fault: The contacts for the pressure sensor have been interrupted or have shorted.	No heating operation and no DHW.
		Blocking fault: The contacts for the pressure sensor have shorted.	No heating operation and no DHW.
		Blocking fault: The contacts for the return temperature sensor have shorted.	No heating operation and no DHW.
		Blocking fault: The contacts for the return temperature sensor have been interrupted.	No heating operation and no DHW.
		Locking fault: The UBA 3 or the KIM is defective.	No heating operation and no DHW.
		Blocking fault: The UBA 3 or the KIM is defective.	No heating operation and no DHW.
		Operating phase: The system pressure is too low (less than 12 psi [0.8 bar]).	No heating operation and no DHW.
		Operating phase: The system pressure is too low (less than 12 psi [0.8 bar]).	No heating operation and no DHW.
		Operating phase: The system pressure is too high (higher than 58 psi [4.0 bar]).	No heating operation and no DHW.
		Locking fault: Reset is carried out. This code appears after the "Reset" button on the display was pressed for 5 seconds.	No heating operation and no DHW.

Table 23 Display codes

- 1) Any display code with a dot in bottom right hand corner.
- 2) Any display code with a blinking dot in bottom right hand corner.
- 3) Any display code starting with the letter E (except EL).

14 Technical specifications

14.1 Technical specifications of GB162-boilers at sea level (0-4,000 ft.)

General specifications	unit	GB162-80 (NG)	GB162-80 (LP)	GB162-100 (NG)	GB162-100 (LP)
Gas category		Natural gas	Propane	Natural gas	Propane
Rated thermal load	btu/h	72,000-290,000	62,000-270,000	72,000-333,000	62,000-315,000
Rated heating capacity, heating curve 176/140 °F (80/60 °C)	btu/h	64,100-255,200	55,200-237,600	64,100-293,000	55,200-277,200
Rated heating capacity, heating curve 122/86 °F (50/30 °C)	btu/h	71,300-281,300	61,400-261,900	71,300-326,300	61,400-308,700
Boiler efficiency at max. capacity, heating curve 176/140 °F (80/60 °C)	%	88		88	
Boiler efficiency at max. capacity, heating curve 122/86 °F (50/30 °C)	%	97		98	
CSA Output	btu/h	261,000	243,000	295,000	279,000
De-ration altitudes 2,000 - 4,000 ft.	% / 1,000 ft.	2.3	2.2	2.1	2.0
AFUE at 80/180 °F (27/82 °C)		93.8	93.9	n/a	n/a
BTS 2000 at 80/180 °F (27/82 °C), partial load		n/a	n/a	96.1	96.1
BTS 2000 at 80/180 °F (27/82 °C), full load		n/a	n/a	90.8	90.8
Heating					
Maximum flow temperature	°F (°C)	180 (82)			
Maximum working pressure (boiler)	psi (bar)	50 (3.6)			
Minimum water circulation volume	Gal/h (l/h)	0			
Flow temperature	°F (°C)	86-180 (30-82), can be set on the BC10 basic controller			
Resistance at ΔT = 20 K	psi (bar)	3.26 (225)		4.57 (315)	
Heating circuit volume of heat exchanger	Gal l	1.3 (5.0)			
Pipe connections boiler, without pump group					
Gas connection	in	Rp 1"			
Heating water connection	in	G 1½" union nut with female thread enclosed			
Condensate connection	in (mm)	Ø 1¼" (32)			
Flue gas values					
Condensate quantity at 104/86 °F (40/30 °C)	Gal/h (L/h)	2.4 (9.0)		2.85 (10.8)	
pH value of condensate	pH	approx. 4.1			
Flue gas mass flow rate, full load	g/s	35.3		44.9	
Flue gas temperature 176/140 °F (80/60 °C), full load	°F (°C)	153 (67)	149 (65)	169 (76)	165 (63)
Flue gas temperature 176/140 °F (80/60 °C), partial load	°F (°C)	142 (61)	136 (58)	142 (61)	136 (58)
Flue gas temperature 122/86 °F (50/30 °C), full load	°F (°C)	118 (48)	114 (46)	124 (51)	120 (49)
Flue gas temperature 122/86 °F (50/30 °C), partial load	°F (°C)	93 (34)	88 (31)	96 (34)	88 (31)
CO ₂ content at full load	%	9.3 ± 0,2%	9.6	9.4 ± 0,2%	9.7
Free fan feed pressure	" w.c. (Pa)	0.602 (150)		0.883 (220)	
Flue gas connection					
Ø Flue gas system, room-air dependent	in (mm)	Ø 4" (100)			
Ø Flue gas system, room-air independent	in (mm)	Ø 4" (100)/ 4" (100) parallel			

Table 24 Technical specifications of GB162-boilers at sea level

General specifications	unit	GB162-80 (NG)	GB162-80 (LP)	GB162-100 (NG)	GB162-100 (LP)
Electrical data					
Mains connection voltage	VAC, Hz	120, 60			
Electrical protection rating		IPX4D			
Fuses	Amp	5			
Electrical power consumption, full load (without a pump group)	W	104		156	
Electrical power consumption, partial load (without a pump group)	W	29		29	
Boiler dimensions and weight					
Height × width × depth (with pump group)	in (mm)	50.4 × 20.5 × 18.3 (1280 × 520 × 465)			
Weight (without a pump group)	lb (kg)	154 (70)			
Other specifications					
Pump group pump		UP 26-99			

Table 24 Technical specifications of GB162-boilers at sea level

Thermal power gas boiler	Type of gas supply	Altitude in kwh (m)	Gas orifice diameter in mm (inch)	Set number with orifice
GB 162-80 kW/100 kW	Natural gas	0 - 4,000 (0 - 1,220)	8.40 (0.331)	7746900399
	LPG	0 - 4,000 (0 - 1,220)	4,70 (0.193)	7746900499

Table 25 Gas orifice diameter

Type of gas supply	Factory pre-setting of the gas control valve
Natural gas	Delivered factory-set: Natural Gas
LP-gas	Suitable for propane after conversion (also see the instruction "Conversion to another type of gas supply"). Information on gas type instruction plate: Set to gas category: Propane.

Table 26 Factory setting of the gas control valve

- The gas orifice diameter is marked on the gas orifice (in mm).

Hydraulic resistance of the boiler

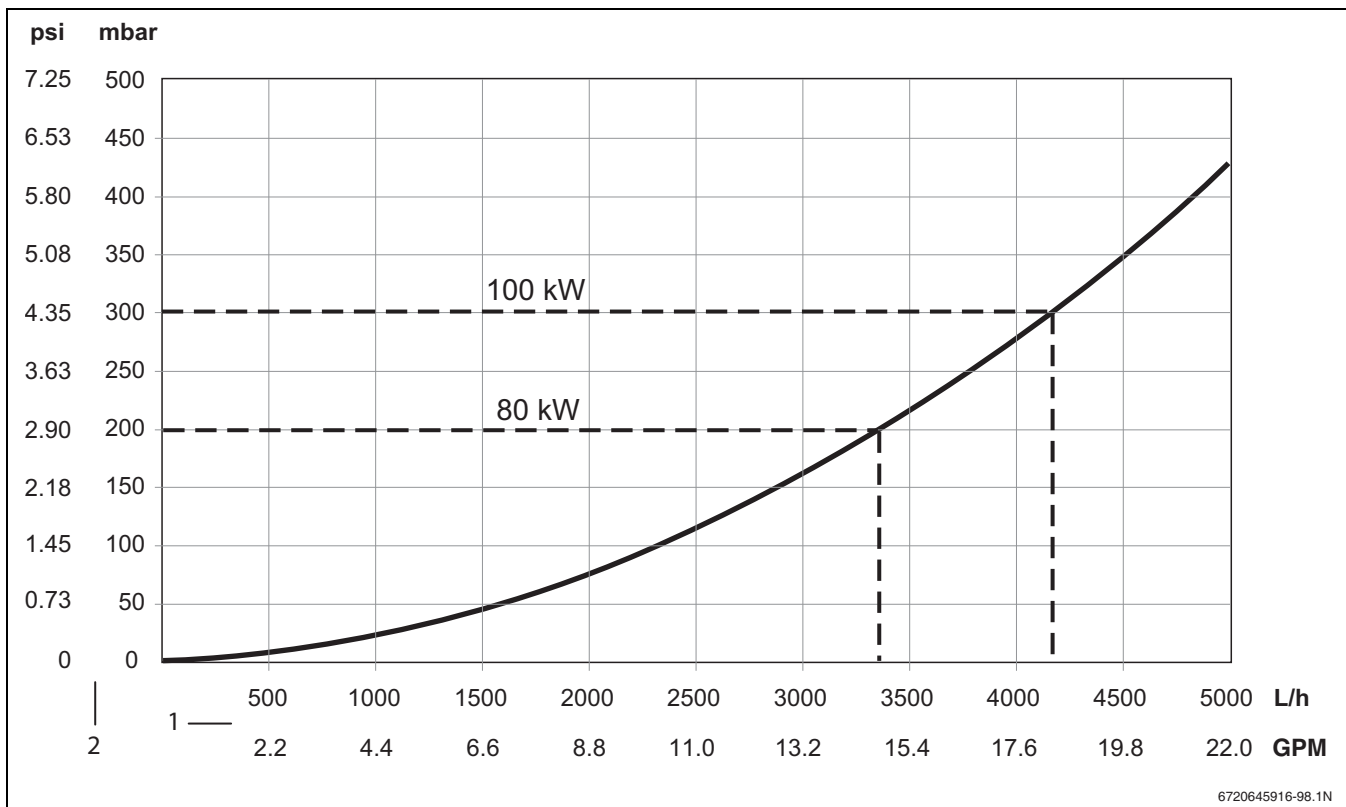

Fig. 100 Boiler resistance curve

- [1] Volume flow
- [2] Pressure drop

15.2 Inspection report

► Indicate the inspection activities that have been carried out, enter the values measured and enter your signature and the date.

Inspection activities	See paragraph	Date:	Date:	Date:	Date:	Date:	Date:	Date:
		_____	_____	_____	_____	_____	_____	_____
1. Check the general condition of the heating system		<input type="checkbox"/>	<input type="checkbox"/>	<input type="checkbox"/>	<input type="checkbox"/>	<input type="checkbox"/>	<input type="checkbox"/>	<input type="checkbox"/>
2. Carry out a visual inspection and function test of the heating system		<input type="checkbox"/>	<input type="checkbox"/>	<input type="checkbox"/>	<input type="checkbox"/>	<input type="checkbox"/>	<input type="checkbox"/>	<input type="checkbox"/>
3. Checking the gas and water-bearing system components for: - Operational tightness - Visible corrosion - Signs of wear - Fill the condensate trap	§ 9.9, page 39 § 11.2, page 43 § 9.3, page 35	<input type="checkbox"/>	<input type="checkbox"/>	<input type="checkbox"/>	<input type="checkbox"/>	<input type="checkbox"/>	<input type="checkbox"/>	<input type="checkbox"/>
4. Measure the ionization current	§ 9.12, page 40	_____ μA	_____ μA	_____ μA	_____ μA	_____ μA	_____ μA	_____ μA
5. Measure the gas inlet pressure (working pressure)	§ 9.7, page 36	_____ " W.C.	_____ " W.C.	_____ " W.C.	_____ " W.C.	_____ " W.C.	_____ " W.C.	_____ " W.C.
6. Check and adjust the flue gases CO ₂ emissions	§ 9.10, page 39	_____ " W.C.	_____ " W.C.	_____ " W.C.	_____ " W.C.	_____ " W.C.	_____ " W.C.	_____ " W.C.
7. Carry out a leakage test in operating conditions	§ 9.9, page 39	<input type="checkbox"/>	<input type="checkbox"/>	<input type="checkbox"/>	<input type="checkbox"/>	<input type="checkbox"/>	<input type="checkbox"/>	<input type="checkbox"/>
8. Check and adjust the flue gases CO ₂ emissions	§ 9.10, page 39	_____ ppm	_____ ppm	_____ ppm	_____ ppm	_____ ppm	_____ ppm	_____ ppm
9. Fill the heating system - Pre-pressure of expansion vessel (also see installation instructions for expansion vessel) - Filling pressure	§ 9.2, page 34	<input type="checkbox"/> _____ psi _____ psi	<input type="checkbox"/> _____ psi _____ psi	<input type="checkbox"/> _____ psi _____ psi	<input type="checkbox"/> _____ psi _____ psi	<input type="checkbox"/> _____ psi _____ psi	<input type="checkbox"/> _____ psi _____ psi	<input type="checkbox"/> _____ psi _____ psi
10. Check the air/flue gas connection	§ 9.5, page 36	<input type="checkbox"/>	<input type="checkbox"/>	<input type="checkbox"/>	<input type="checkbox"/>	<input type="checkbox"/>	<input type="checkbox"/>	<input type="checkbox"/>
11. Checking the boiler settings of the control device (in accordance with requirements)	documents for the control device.	<input type="checkbox"/>	<input type="checkbox"/>	<input type="checkbox"/>	<input type="checkbox"/>	<input type="checkbox"/>	<input type="checkbox"/>	<input type="checkbox"/>
12. Final check of the inspection activities, documenting the measurement and test results		<input type="checkbox"/>	<input type="checkbox"/>	<input type="checkbox"/>	<input type="checkbox"/>	<input type="checkbox"/>	<input type="checkbox"/>	<input type="checkbox"/>
13. Confirming proper inspection		Company stamp/ signature	Company stamp/ signature	Company stamp/ signature	Company stamp/ signature	Company stamp/ signature	Company stamp/ signature	Company stamp/ signature

Table 28 Inspection report

15.3 Service report

► Indicate the maintenance activities that have been carried out, enter the values measured and enter your signature and the date.

Needs-dependant maintenance activities	Page	Date:	Date:	Date:	Date:	Date:	Date:	Date:
		_____	_____	_____	_____	_____	_____	_____
1. Clean the heat exchanger, burner and condensate trap	page 45	<input type="checkbox"/>	<input type="checkbox"/>	<input type="checkbox"/>	<input type="checkbox"/>	<input type="checkbox"/>	<input type="checkbox"/>	<input type="checkbox"/>
2. Check and adjust the flue gases CO ₂ emissions - CO ₂ content at full load - CO ₂ content at part load	page 39	_____ " W.C. _____% _____%	_____ " W.C. _____% _____%	_____ " W.C. _____% _____%	_____ " W.C. _____% _____%	_____ " W.C. _____% _____%	_____ " W.C. _____% _____%	_____ " W.C. _____% _____%
3. Function check	page 48	<input type="checkbox"/>	<input type="checkbox"/>	<input type="checkbox"/>	<input type="checkbox"/>	<input type="checkbox"/>	<input type="checkbox"/>	<input type="checkbox"/>
4. Confirming proper inspection		Company stamp/ signature	Company stamp/ signature	Company stamp/ signature	Company stamp/ signature	Company stamp/ signature	Company stamp/ signature	Company stamp/ signature

Table 29 Service report

16 Spare parts

The following are parts commonly required due to damage or replacements. Their failure will affect safety or performance of this appliance.

For a pictorial representation of the part see the respective position number on the exploded view pictures on page 61 and page 62.

	Description	Product No.
1	Door USA	8718600178
2	Sealing door	7101382
3	Door lock	7101384
4	Hinge door	7101520
5	Wall mounting bracket	7101386
6	Bracket left	7101388
7	Bracket right	7101390
8	Adjusting foot	7101394
9	Transport slide (L+R)	7101392
10	Drawer modules	7101496
11	Screw 4.2x8.5 (10 pc)	7100748
12	Condensate collector	7101396
13	Seal condensate collector	7746900152
14	Seal Ø 3.2" (80 mm)	7101400
15	Upper side condensate collectors	7101402
16	Mounting flue-gas pipe	7101398
17	Exhaust pipe	7101404
20	Condensate collector	8718600611
21	Seal condensate collector	73463
22	Drain pipe	7101410
23	Sealing bush (white)	73449
24	Condensate drain pipe	7101535
25	Fan	7746900382
26	Seal fan	7101450
27	O-ring 70x3 (2 pc)	7101416
28	Venturi	7746901751
29	Seal Ø 2.4" (60 mm)	73563
30	Gas valve, natural gas	8718600291
30	Gas valve, LP-gas	8718600323
31	Seal 33 x 24 x 3.5 (10 pc)	7098962
32	Gas pipe	7746900397
33	Flange gas valve	8718600286
34	O-ring (10 pc)	7101504
36	Screw M5 x 20 (10 pc)	7099650
37	Screw M5 x 16 (10 pc)	7101484
38	Screw M6 x 20 (10 pc)	7101486
39	Air inlet pipe	7101462
40	Sealing (10 pc)	7101482
41	Air vent revision set	7101428
42	Clip	7101430
43	Sensor NTC	7746900391
44	Clip (4 x 2 pc)	7746700063
45	O-ring 9.19 x 2.62 (10 pc)	78175s

Table 30 Spare parts

	Description	Product No.
46	Pressure sensor	8718600019
47	O-ring 14 x 1.78 (10 pc)	7101646
48	Return/supply pipe	7101438
49	Connection nipple CH	73080
50	Clip	7746700069
51	O-ring (10 pc)	7101488
52	Flue gas sensor	7746700420
56	Mounting set with sight glass with glow ignitor with ionization electrode	8718600172
60	Heat exchanger	7746900383
61	Cover controller BC10	73698
62	Burner	7101444
63	Seal Burner	7101446
65	Burner box	7101448
66	Front connection board	7101490
67	BC10 USA	78186
68	On/off switch	7099041
69	Knob BC10	38724
70	Draw connection board	7101480
71	Cover control box	7101498
73	Transformer	78191
74	UBA 3	8718600083
75	Fuse 5AF (10 pc)	8718601966
76	Connection board	7099042
77	Electronic connection red	73776
78	Electronic connection grey	73774
79	Electronic connection grey	73773
80	Electronic connection blue	73775
81	Electronic connection orange	73777
83	Flue gas adapter	73936
84	Measure nipple cap	7101424
86	Cable harness low voltage	7746900392
87	Cable harness high voltage	7746900393
88	Cable harness on/off switch	7101476
89	Cable harness earth	7101474
91	Union nut 1½" (5 pc)	73481s
92	Sealing (5 pc)	7746700417
93	Nut 1"	7099416
95	Gas valve	7746900401
96	Pump UP26-99U	7746900402
98	Level ball valve blue	7746700421
99	Level ball valve red	7746700422
100	Casing	7101514
101	Thermometer	7746900404
102	Manometer	7101506
105	Valve housing return	74549
106	Air release tap	7746900403

Table 30 Spare parts

	Description	Product No.
107	Connection pressure gauge	73081
108	Drain pipe	7101410
109	Valve housing supply	7746900406
110	Adapter parallel 4"	7746900384
111	Adapter insert 4"	7746900385
112	Open venting insert	7746900386
113	Lip ring 114	7746900387
114	Lip ring 103	7746900388
117	Strain relief bracket	7746900398
118	Safety valve ASME	7746900405
119	Low loss header	7746901646
120	plug protector	73948
-	AM10	7746900020
-	BCM 1100– 100 kW (0-4,000 ft.)	8718600725
-	BCM 1101– 80 kW (0-4,000 ft.)	8718600726
-	Screw 6.3 x 19 (10 pc)	73986

Table 30 Spare parts

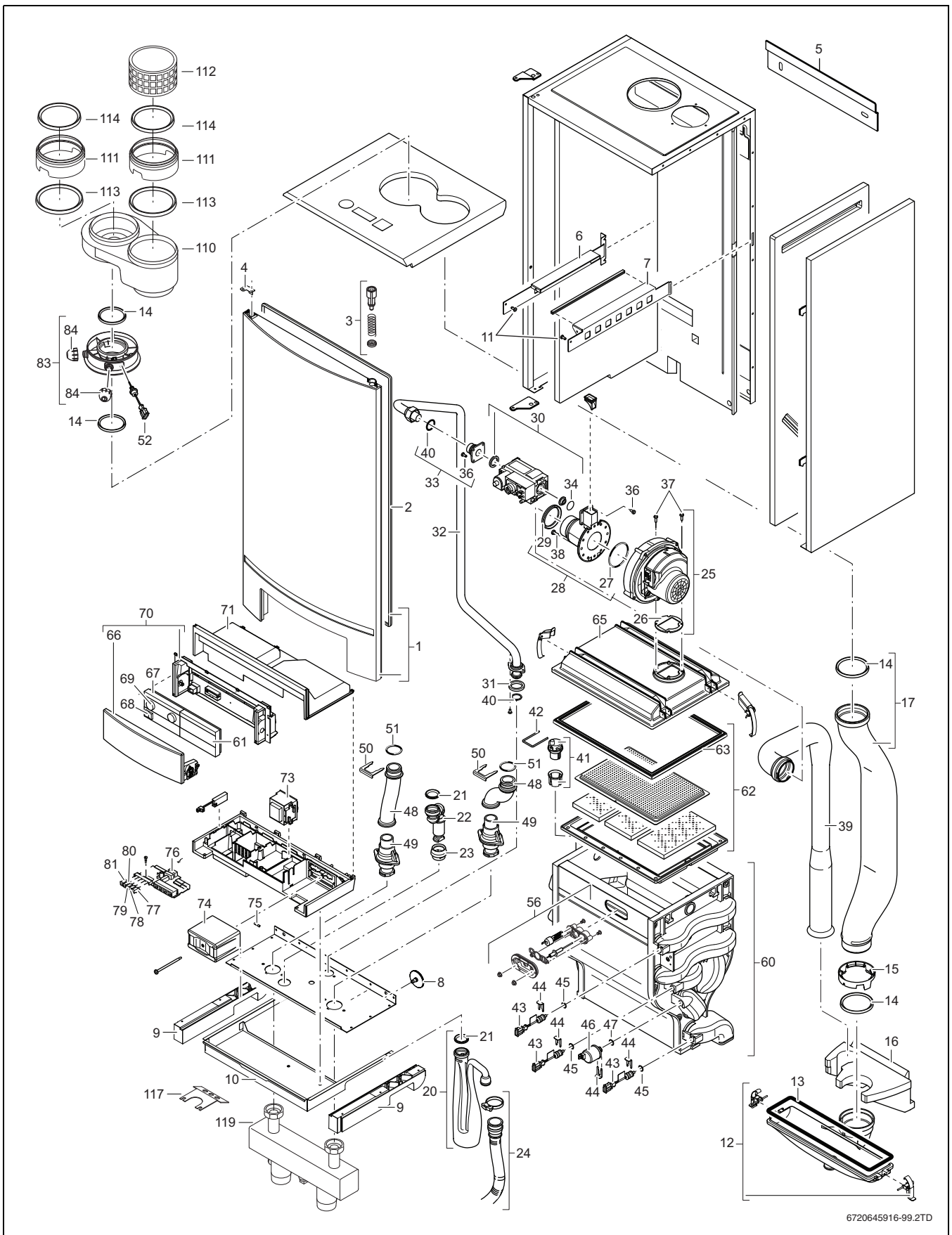

6720645916-99.2TD

Fig. 101 Exploded view Logamax plus GB162-80 kW/100 kW

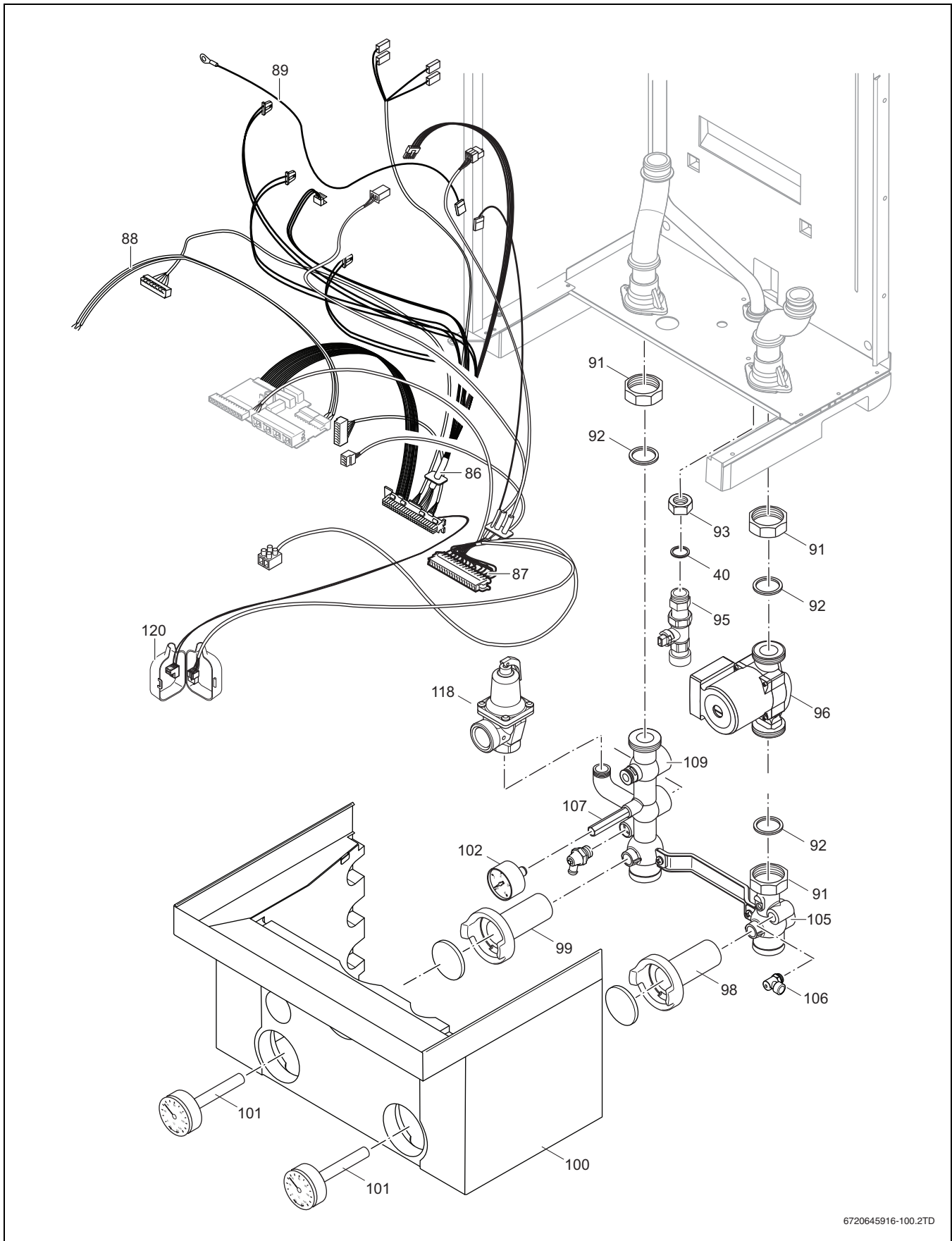

6720645916-100.2TD

Fig. 102 Exploded view pump group Logamax plus GB162-80 kW/100 kW

Index

A

Appliance configuration 36

B

BC10 basic controller 30

Burner 45

C

Carbon monoxide content 39

CO values 39

Condensate collector 47

Condensate trap 35, 45–46

Connections 9, 13, 24

D

DHW circulation pump 26

DHW pump 26

Dimensions 9–10

Display 30

Display codes 50

Drain 42

E

Emergency 42

F

Fault 49–50

Flow temperature 55

Flue gas connection 36, 55

Flue gas test 31

Freeze damage 42

Freeze protection 8

Function module 26

Function test 39

G

Gas connection 14

Gas supply valve 35

Gas tightness 35

Gas/air ratio 38

H

Heat exchanger 45, 48

Heating capacity 41

Heating system water 7

Hydraulic resistance 56

I

Ignition unit 46

Inspection report 58

Installation room 12

Ionization current 40

L

Leakage test 34, 39, 43

Log book 33

M

Main power switch 30

Manual operation 32

Menu structure 31

N

Normal operation 31

P

Pump run-over time 8, 41

Pump test 8

R

Room controller 26

S

Safety 33

Service mode 31

Service Tool 30

Settings 32

Shutting down 42

Signs of corrosion 43

Space heating 30

T

Technical specifications 55

Transportation 11

W

Working pressure 36, 55

United States and Canada

Bosch Thermotechnology Corp.
50 Wentworth Avenue
Londonderry, NH 03053
Tel. 603-552-1100
Fax 603-965-7581
www.bosch-climate.us
U.S.A.

Products manufactured by
Bosch Thermotechnik GmbH
Junkersstrasse 20-24
D-73249 Wernau
www.bosch-thermotechnology.com

Bosch Thermotechnology Corp. reserves the right
to make changes without notice due to continuing
engineering and technological advances.

Buderus