Slide Rail Systems - Series A10

INSTALLATION, OPERATION AND MAINTENANCE INSTRUCTIONS



CentriPro

a xylem brand

TABLE OF CONTENTS

SUBJECT	PAGE
Safety Instructions	3
Descriptions and Specifications.....	3
Piping.....	3
Slide Rail Installation.....	3
Operation.....	6
Working Load Limits.....	6
Warnings	6
Limited Warranty	8

Owner's Information

Pump Model Number: _____

Pump Serial Number: _____

Control Model Number: _____

Dealer: _____

Dealer Phone No. _____

Date of Purchase: _____ Installation: _____

SAFETY INSTRUCTIONS

TO AVOID SERIOUS OR FATAL PERSONAL INJURY OR MAJOR PROPERTY DAMAGE, READ AND FOLLOW ALL SAFETY INSTRUCTIONS IN MANUAL AND ON PUMP.

THIS MANUAL IS INTENDED TO ASSIST IN THE INSTALLATION AND OPERATION OF THIS UNIT AND MUST BE KEPT WITH THE SLIDE RAIL.



This is a SAFETY ALERT SYMBOL. When you see this symbol on the pump or in the manual, look for one of the following signal words and be alert to the potential for personal injury or property damage.

⚠ DANGER Warns of hazards that **WILL** cause serious personal injury, death or major property damage.

⚠ WARNING Warns of hazards that **CAN** cause serious personal injury, death or major property damage.

⚠ CAUTION Warns of hazards that **CAN** cause personal injury or property damage.

NOTICE: INDICATES SPECIAL INSTRUCTIONS WHICH ARE VERY IMPORTANT AND MUST BE FOLLOWED.

⚠ WARNING HAZARDOUS LIQUIDS OR FLAMMABLE GASES CAN CAUSE FIRE, BURNS OR DEATH.



Hazardous fluids can cause fire, burns or death.

THOROUGHLY REVIEW ALL INSTRUCTIONS AND WARNINGS PRIOR TO PERFORMING ANY WORK ON THIS UNIT.

MAINTAIN ALL SAFETY DECALS.

NOTICE: INSPECT UNIT FOR DAMAGE AND REPORT ALL DAMAGE TO THE CARRIER OR DEALER IMMEDIATELY.

DESCRIPTIONS AND SPECIFICATIONS

Goulds Pumps A10 slide rail systems provide easy wet well pump removal, utilize a self-cleaning quick disconnect and guide assembly, and eliminate the need to enter the wet well.

Model	Slide Rail Discharge	Pump Discharge
A10-12	1¼" NPTM	1¼" F
A10-2015	1½" NPTM	1½" F
A10-20	2" NPTM	2" F
A10-30 and A10-40	4" 125# ANSI Flange	3" ANSI Flange 4" ANSI Flange
A10-60	6" 125# ANSI Flange	4" ANSI Flange

PIPING

System piping **MUST** conform to all local and national plumbing codes and practices.

To maximize the discharge flow, discharge piping should be at least as large as the pump discharge. Keep the discharge pipe as short as possible and avoid unnecessary fittings.

SLIDE RAIL INSTALLATION

⚠ WARNING



Hazardous voltage can shock, burn or cause death.

FAILURE TO DISCONNECT AND LOCKOUT ELECTRICAL POWER BEFORE ATTEMPTING ANY MAINTENANCE CAN CAUSE SHOCK, BURNS OR DEATH.

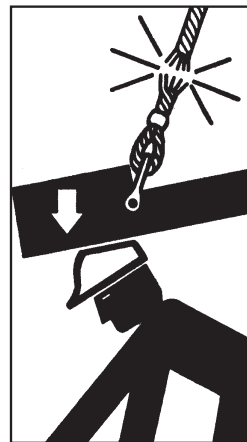

⚠ WARNING

Wire rope **WILL FAIL** if worn-out, overloaded, misused, damaged, improperly maintained or abused.

Wire rope failure may cause serious injury or death!

Protect yourself and others:

- ALWAYS INSPECT wire rope for WEAR, DAMAGE or ABUSE BEFORE USE.
- NEVER USE wire rope that is WORN-OUT, DAMAGED or ABUSED.
- NEVER OVERLOAD a wire rope.
- INFORM YOURSELF: Read and understand manufacturer's literature or "Wire Rope and Wire Rope Sling Safety Bulletin".*
- REFER TO APPLICABLE CODES, STANDARDS and REGULATIONS for INSPECTION REQUIREMENTS and REMOVAL CRITERIA.*

* For additional information or the BULLETIN, ask your employer or wire rope supplier.

© 1993, Wire Rope Technical Board

Form No. 193

NOTICE: ALL DIMENSIONS ARE IN INCHES. DO NOT USE DIMENSIONAL DATA FOR CONSTRUCTION PURPOSES.

Installation of the slide rail system should locate the pump opposite the influent opening, preventing stagnate areas where solids can settle.

NOTICE: GUIDE RAILS MUST BE PLUMB TO FACILITATE PUMP(S) INSTALLATION OR REMOVAL.

The containment area floor **MUST** be flat under the slide rail base and have sufficient loading capacity to support the entire weight of the assembly, including the slide rail base, slide rail guide, pump and all assorted piping.

Prior to anchoring the slide rail base to the containment area floor, ensure adequate clearance for pump(s) installation or removal AND for access doors.

NOTICE: MATERIAL SELECTION FOR CONTAINMENT AREA EQUIPMENT MUST BE COMPATIBLE WITH ANTICIPATED FLUIDS AND SERVICE.

Slide Rail Systems – A10-12, A10-20, A10-2015

Typical hardware specifications, piping arrangements and basin attachment dimensions are provided in Figure 1 and Table 1.

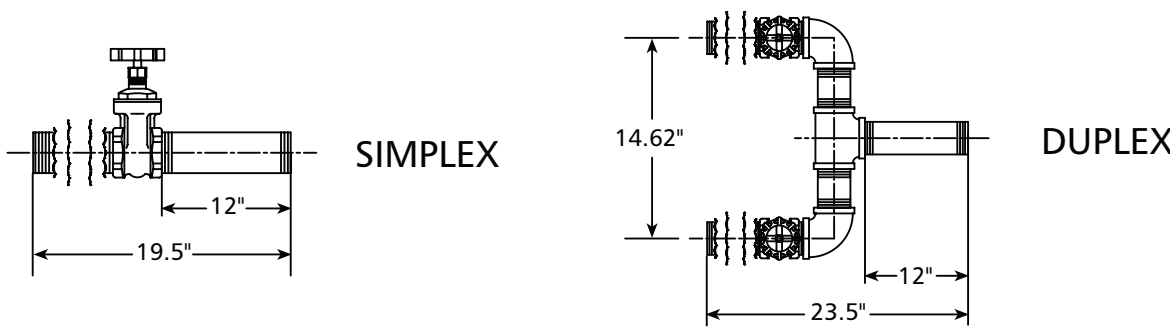
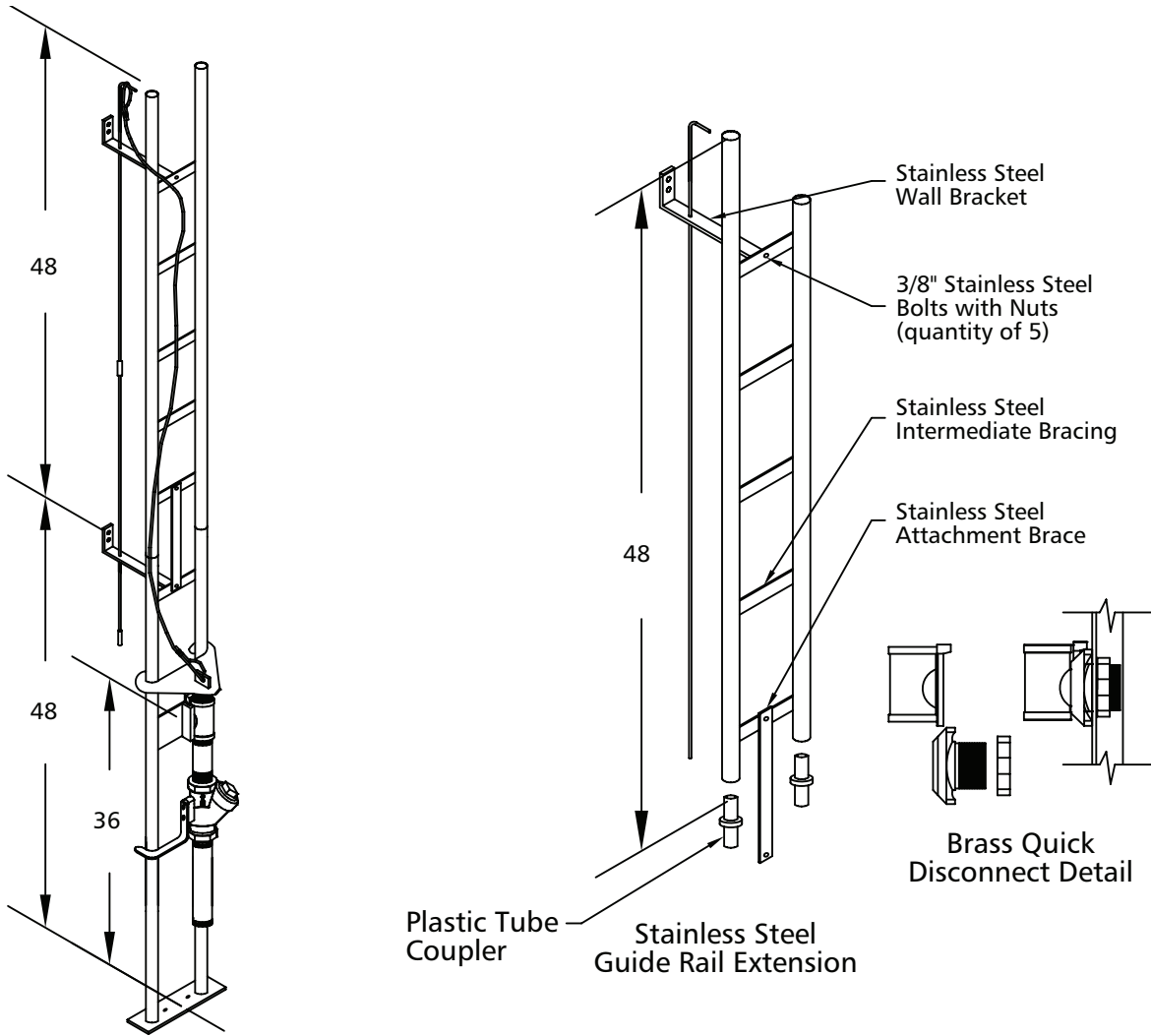

A10-12, A10-20, A10-2015
Figure 1

Table 1: Guide Rail Base Dimensions

SIZE	A"	B"	C"
A10-12	3	4½	10
A10-20	3¾	5½	12
A10-2015	3¾	5½	12

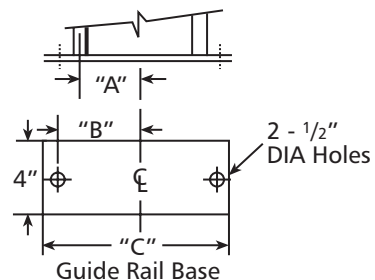

Slide Rail Systems – A10-30 and A10-40

The A10-30 system is designed for pumps with a 3", 125# ANSI flanged discharge. The A10-40 system is designed for pumps with a 4", 125# ANSI flanged discharge. Both 3" and 4" flanged pumps bolt directly to their respective slide rail cast iron pump adapters. The adapter, which slides up and down on the rails, mates with the slide rail base and the integrally cast elbow to provide a 4", 125# ANSI flanged discharge connection. See Figure 2 and Table 2 for the typical hardware specifications, piping arrangements and basin attachment dimensions.

Slide Rail Systems – A10-60

The A10-60 system is designed for pumps with a 4", 125# ANSI flanged discharge. The pump bolts directly to the slide rail cast iron pump adapter, mating with the slide rail base and integrally cast elbow to provide a 6", 125# ANSI flanged discharge connection. See Figure 2 and Table 2 for the typical hardware specifications, piping arrangements and basin attachment dimensions.

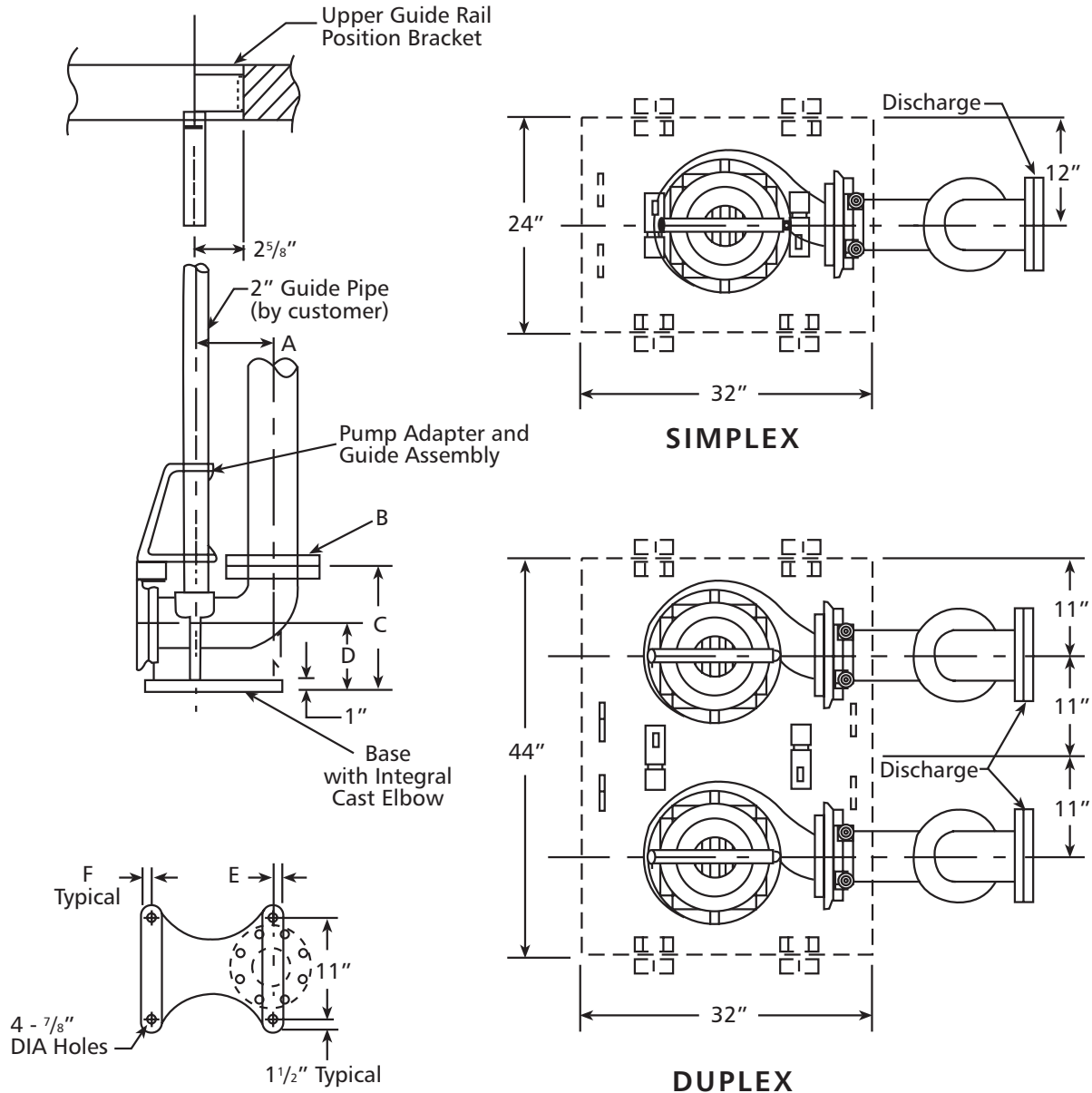

A10-30, A10-40 and A10-60
Figure 2

Table 2

SIZE	A"	B	C"	D"	E"	F"
A10-30	7¼	4" ANSI 125# Flange	12	7	13	1
A10-40	7 ⁵ / ₁₈	4" ANSI 125# Flange	12	7	13	1
A10-60	8 ⁵ / ₁₆	6" ANSI 125# Flange	17	10	15	2

OPERATION



DO NOT LIFT, CARRY OR HANG PUMP BY THE ELECTRICAL CABLE. DAMAGE TO THE ELECTRICAL CABLE CAN CAUSE SHOCK, BURNS OR DEATH.

Raise and lower the pump in the containment area using the lifting cable attached to the system's quick disconnect for the A10-12, A10-2015 or A10-20, and to the pump's lifting eye/strap for the A10-30, A10-40 and A10-60. **DO NOT** use electrical cable and **DO NOT** damage the electrical cables while raising and lowering unit. A10-40 and A10-60 units can be used in conjunction with a lifting bail (part # ABAIL2).

To ensure full prime, lower the pump(s) on the slide rails until fully submerged. Do not engage pump discharge to the rail discharge connection. Jog the pump motor, one to two seconds, to purge air from pump casing. Lower the pump and engage with base.

While the slide rail system mating surfaces are self cleaning and contain no sealing devices, a check for leaks at the initial installation and after each pump removal or installation is recommended.

While manually controlling the pump and the containment area inflow, using each pump independently, pump down the containment area.

Observe the pump, piping and slide rail base discharge connections for leaks.

If leaks are present, reset the pump and slide rail mating surfaces and recheck. If this fails to stop the leak, the pump should be removed and the necessary adjustments made to correct the leak. Leakage will cause longer operation time, higher costs and may lead to premature failure of slide rail base discharge connection.

WORKING LOAD LIMIT

Cable A10-12, A10-20 and A10-2015

The working load limit is based on a load being uniformly applied in a straight line pull.

$\frac{3}{16}$ " 7x19 304SS Air Craft Cable WLL = 740 lbs.

Do not exceed safe working load limits.

WARNINGS

Inspection

Wire ropes, cables and attachments must all be inspected regularly for visible damage or distortion, elongation, corrosion, cracks, nicks or abrasion which may cause failure or reduce the original strength or ability of the products to perform safely. User must determine whether future use of the wire rope or cable would constitute a safety hazard to life or property.

Safety

Refer to WARNING and CAUTION labels prior to use.

Keep out from under any raised loads and keep out of the line of force of any load.

Do not use wire ropes or cables for any purpose other than which it was intended.

AVOID SHOCK LOADS

Warnings

Failure to use wire ropes or cables properly may cause loads to slip or fall.

Failure to read, understand and follow these instructions may cause death or serious injury.

Do not exceed safe working load limits.

	<p>⚠ WARNING</p> <p>Wire rope WILL FAIL if worn-out, overloaded, misused, damaged, improperly maintained or abused. Wire rope failure may cause serious injury or death!</p> <p>Protect yourself and others:</p> <ul style="list-style-type: none">• ALWAYS INSPECT wire rope for, WEAR, DAMAGE or ABUSE BEFORE USE.• NEVER USE wire rope that is WORN-OUT, DAMAGED or ABUSED.• NEVER OVERLOAD a wire rope.• INFORM YOURSELF: Read and understand manufacturer's literature or "Wire Rope and Wire Rope Sling Safety Bulletin".*• REFER TO APPLICABLE CODES, STANDARDS and REGULATIONS for INSPECTION REQUIREMENTS and REMOVAL CRITERIA.* <p>* For additional information or the BULLETIN, ask your employer or wire rope supplier.</p> <p>© 1993, Wire Rope Technical Board Form No. 193</p>
---	---

NOTES

CENTRIPRO LIMITED WARRANTY

This warranty applies to all water systems pumps manufactured by CentriPro.

Any part or parts found to be defective within the warranty period shall be replaced at no charge to the dealer during the warranty period. The warranty period shall exist for a period of twelve (12) months from date of installation or eighteen (18) months from date of manufacture, whichever period is shorter.

A dealer who believes that a warranty claim exists must contact the authorized CentriPro distributor from whom the pump was purchased and furnish complete details regarding the claim. The distributor is authorized to adjust any warranty claims utilizing the CentriPro Customer Service Department.

The warranty excludes:

- (a) Labor, transportation and related costs incurred by the dealer;
- (b) Reinstallation costs of repaired equipment;
- (c) Reinstallation costs of replacement equipment;
- (d) Consequential damages of any kind; and,
- (e) Reimbursement for loss caused by interruption of service.

For purposes of this warranty, the following terms have these definitions:

- (1) "Distributor" means any individual, partnership, corporation, association, or other legal relationship that stands between CentriPro and the dealer in purchases, consignments or contracts for sale of the subject pumps.
- (2) "Dealer" means any individual, partnership, corporation, association, or other legal relationship which engages in the business of selling or leasing pumps to customers.
- (3) "Customer" means any entity who buys or leases the subject pumps from a dealer. The "customer" may mean an individual, partnership, corporation, limited liability company, association or other legal entity which may engage in any type of business.

THIS WARRANTY EXTENDS TO THE DEALER ONLY.



Xylem, Inc.
2881 East Bayard Street Ext., Suite A
Seneca Falls, NY 13148
Phone: (866) 325-4210
Fax: (888) 322-5877
www.xylem.com/brands/centripro

CentriPro is a trademark of Xylem Inc. or one of its subsidiaries.
© 2012 Xylem, Inc. IM042 Revision Number 3 July 2012