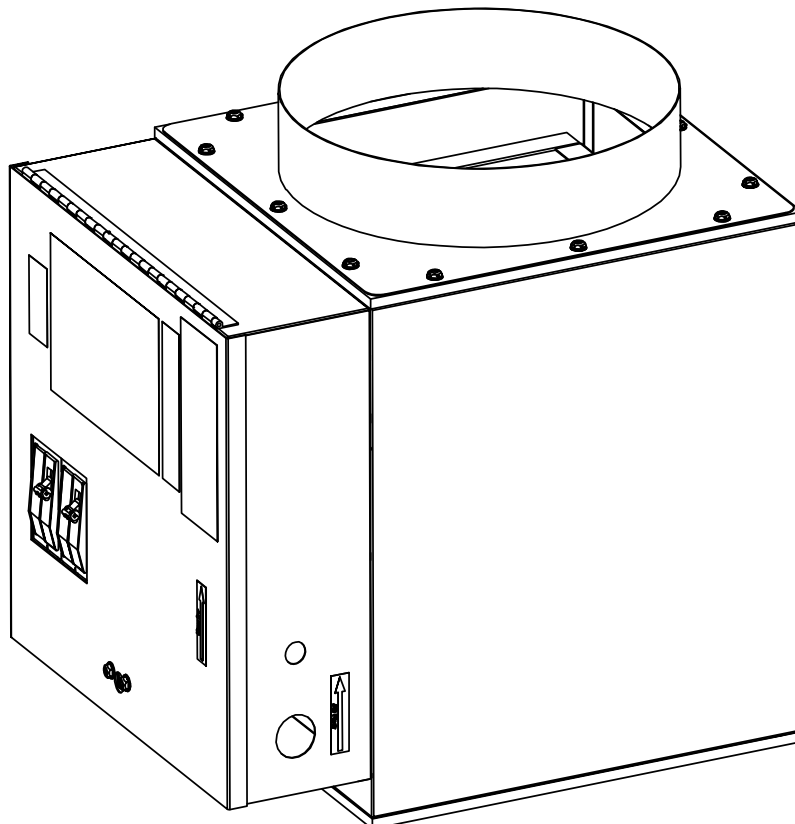


# The Unico System<sup>®</sup>

## ELECTRIC FURNACE INSTALLATION MANUAL

BULLETIN 30-034



# TABLE OF CONTENTS

**Installation Specifications ..... 3**

INTRODUCTION ..... 3

LOCATION..... 3

MOUNTING ..... 3

SPECIAL WIRING FOR HEAT PUMPS..... 8

SEQUENCE OF OPERATION ..... 8

CAPACITY AT LOWER VOLTAGES..... 9

OPTIONAL ADAPTERS AND SPARE PARTS ..... 9

DUCT DESIGN ..... 10

Certified to UL Standard 1995  
 Conforms to CAN/CSA Standard C22.2 NO. 236

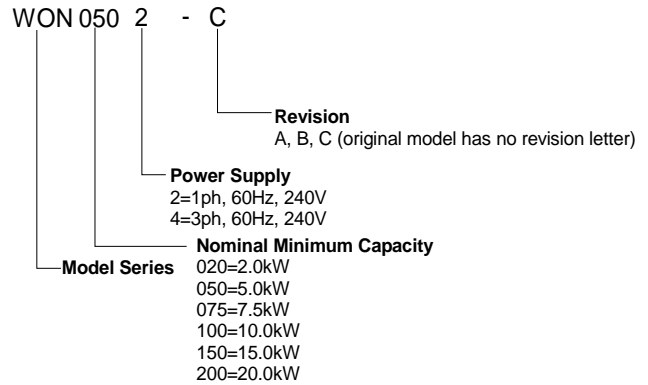


Unico products comply with the European regulations that guarantee product safety.

# Installation Specifications



## Model Number Key



## INTRODUCTION

**General.** The information on the following pages is to provide the installer the necessary information to properly install the *Unico System* electric furnaces. The electric furnaces are designed to provide primary or auxiliary heating. The available model numbers, capacity, and air handler compatibility are shown in the Table 1.

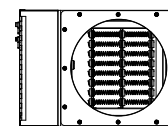
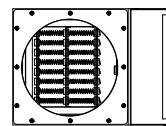
**Table 1. Electric Furnaces**

| Model Number           | Nominal kW Rating | Air Handler Compatibility | Min. Airflow, CFM (m <sup>3</sup> /s) |
|------------------------|-------------------|---------------------------|---------------------------------------|
| WON0202-C              | 2                 | All sizes                 | 100 (0.05)                            |
| WON0502-C<br>WON0504-C | 5                 |                           | 250 (0.12)                            |
| WON0752-C<br>WON0754-C | 7.5               |                           | 300 (0.14)                            |
| WON1002-C<br>WON1004-C | 10                | 2430, 3036, 3642 and 4860 | 500 (0.24)                            |
| WON1502-C<br>WON1504-C | 15                |                           | 600 (0.28)                            |
| WON2002-C              | 20                | 3036, 3642 and 4860       | 800 (0.38)                            |

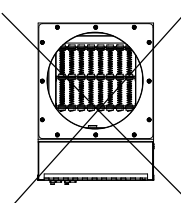
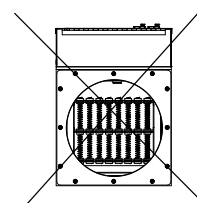
## LOCATION

Before installing the furnace, inspect the unit thoroughly for shipping damage. Check all porcelain insulators for any breaks and inspect the furnace element wire to see that none have been deformed. Check the heating elements for loose connections that could cause overheating. If any shipping damage is found, notify the carrier immediately.

Install the furnace by attaching it directly to the air handler using the adapter collar provided with the furnace. Alternately the furnace can be placed in the duct system to act as a duct heater. For this configuration, an additional duct collar (see table 6 below) must be ordered to correctly install the heater. In either configuration, position the unit so the arrow label on the cover of the electric furnace control box is in the direction of the airflow. The electric furnace control box can be placed on either side of the unit as shown in Figure 1.



Acceptable mounting positions in the horizontal configuration.



Non-Acceptable mounting positions in the horizontal configuration.

IL00487.cvx

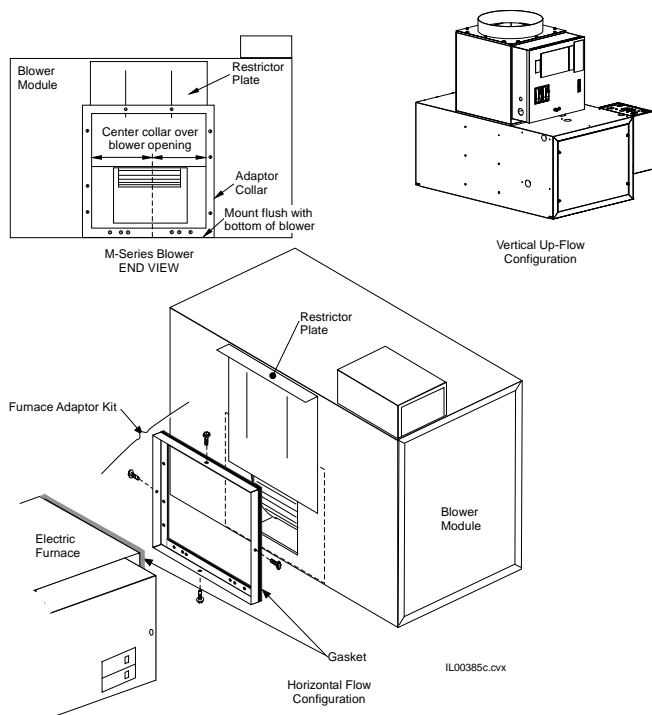
**Figure 1. Orientation of control box (Horizontal airflow)**

## MOUNTING

**Mounting Instructions.** Attach the electric furnace to the unit using the square adapter collar supplied with the electric heater. The electric furnace may be mounted with horizontal or vertical airflow.

The adapter collar should be flush with the edge of the blower cabinet (bottom for the M-series, rear for the V-series, and top for the U-series). Center the collar horizontally over the blower opening. Use the #10 x 3/8" type AB sheet metal screws located inside the bulletin packet shipped with the blower module to attach the adapter collar to the air handler.

If the blower has a single-speed motor, you must install the restrictor plate. **DO NOT USE THE RESTRICTOR PLATE WITH VARIABLE SPEED MOTORS.** Slide the restrictor plate behind the adapter collar to the full open position (see Figure 2).



**Figure 2. Furnace Installation**

Insert the furnace into the furnace adaptor and secure it using the (4) #8 x 3/4" modified Phillips head self-drilling screws shipped with the electric furnace. If using a restrictor plate, adjust the plate to the proper airflow (refer to *Bulletin 30-020*) then use #10 x 3/8" type AB sheet metal screws located inside the bulletin packet shipped with the blower module to secure the restrictor plate in place.

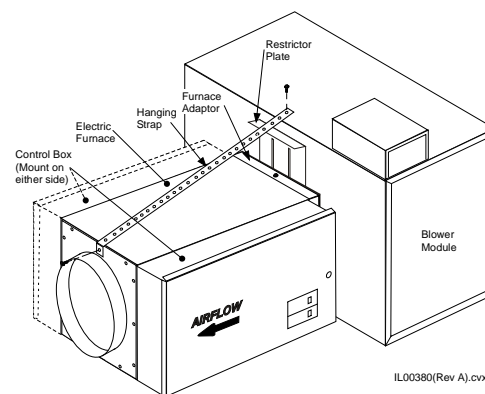
For vertical installations, mount the electrical furnace control box in any position. The circuit breaker can be repositioned for vertical installations, if needed, so that the switch is in the down position when turned off.

For horizontal air flow applications, be sure the electric furnace is fully supported using the supplied strap. If the

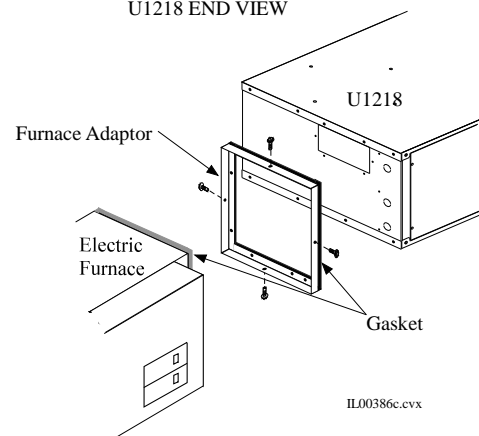
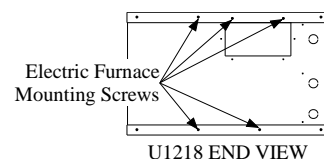
furnace is not supported from underneath the unit, use a hanging strap to support the furnace by attaching one side to the top of the air handler and the other to the end of the furnace as shown in figure 3 and 4. Mount the furnace with the control box on either side. **Do not install the furnace with the control box on top or bottom.**

Support the furnace on the rafters, floor, or platform with the air handler. If using a platform, make it large enough to support the entire furnace and air handler. Rest the platform on the floor or hang it with chains or cables. Refer to Bulletin 30-20 for mounting instructions.

**CAUTION**  
**DO NOT HANG UNIT DIRECTLY FROM HOUSING TO PREVENT DAMAGE TO THE ELECTRICAL ELEMENTS.**



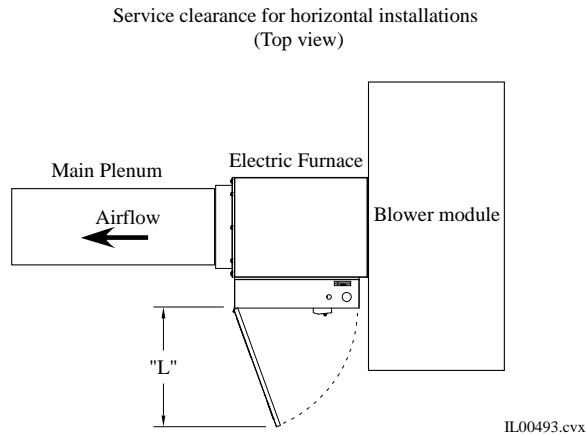
**Figure 3. Hanging Strap Placement**



Note: Do not use the restrictor plate on the U1218 models

**Figure 4. U1218 Electric Furnace Mounting**

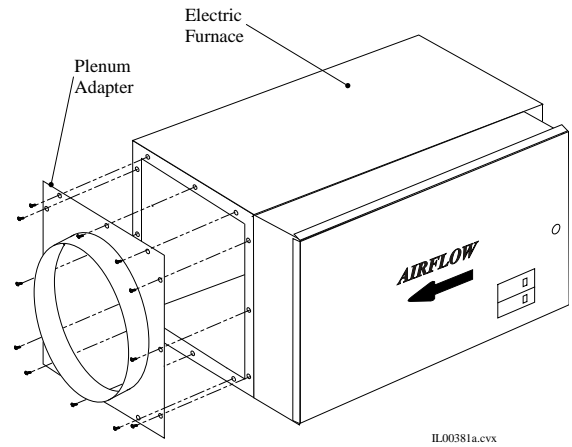
All furnaces are suitable for zero clearance between the duct and combustible material. For servicing the control box, allow enough room (“L”) to swing the cover open and to service the blower module (Figure 5). The hinge is located on the electric furnace control box closest to the discharge end of the electric furnace.



| Models  | "L"  |
|---|------|
| WON0202, WON0502                                  | 13.0 |
| WON0752, WON1002                                  | 16.0 |
| WON1502, WON0504,<br>WON0754, WON1004,<br>WON1504 | 21.0 |
| WON2002   | 24.0 |

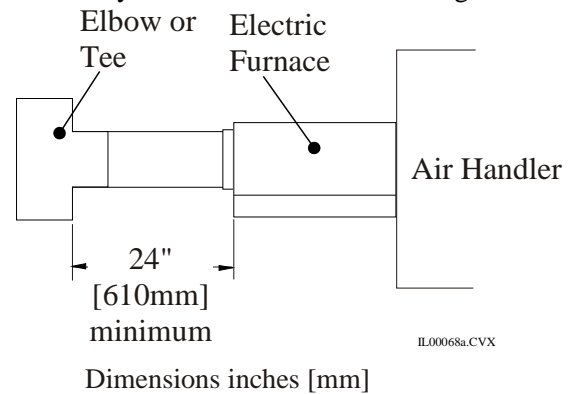
**Figure 5. Service clearance for horizontal installations**

For round metal plenum systems, use the correct diameter metal pipe adapter for you plenum size. For example, the 1218 and 2430 systems typically use 7-inch (178mm), the 3642 system uses 9-inch (228.6-mm), and the 4860 systems use 10-inch (254mm) diameter pipe. Figure 6 shows the installation of the Plenum adapter (10-inch round plenum adapter is already attached).



**Figure 6. Start Collar Installation**

Always allow a minimum of 24 inches (610 mm) of straight duct between the discharge side of the electric furnace and any tee or elbow as shown in figure 7.

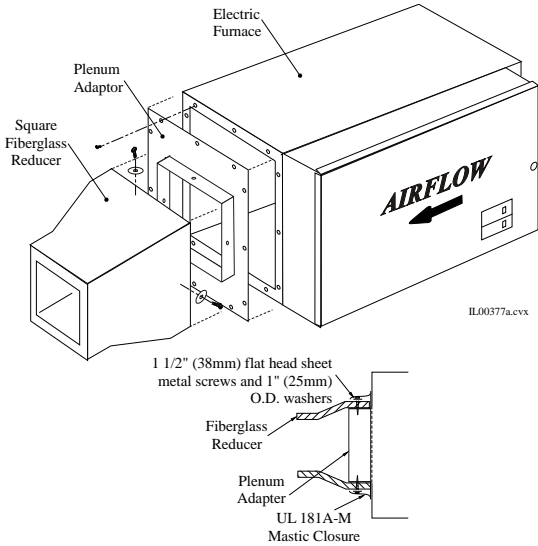


**Figure 7. Minimum distance from duct to furnace**

The furnace also includes a 9½ × 9½-inch (241 × 241-mm) square plenum adapter. If the plenum is smaller, then use a reducer fitting. Fiberglass reducers are available to reduce the 9½-inch (241mm) square duct to 8½-inch (216-mm) or 6½-inch (165mm) square duct as shown in table 7. Alternately, the reducer can be eliminated if you use the metal plenum adapter shown in table 6.

The plenum adapters are designed to fit inside the square duct and are secured with sheet metal screws and washers. The joint must be sealed per UL-181A-M or UL-181A-P as seen in figure 8 to ensure an air tight system.

Note: All metal connections must be mechanically fastened with sheet metal screws and the joints and seams must be taped with UL-181A-P foil faced tape or sealed with UL-181A-M duct mastic.

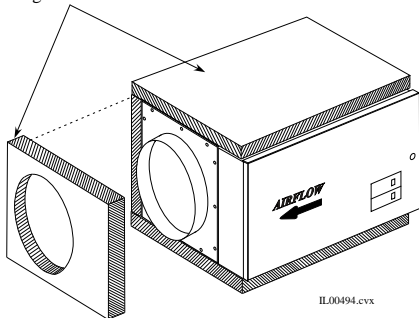


**Figure 8. Square Duct Installation (Furnace shown with optional square plenum adapter)**

Insulate all metal ducting with 1.5-inch (38-mm) minimum fiberglass insulation. For round duct, use either sleeve insulation or foil-faced duct wrap. For square duct use either fiberglass duct board or foil-faced duct wrap. Tape all seams to prevent air leaks.

**High Humidity.** When the furnace is installed in high humidity areas, such as an unconditioned attic or crawlspace, there is a possibility of condensation forming on the furnace cabinet during the cooling mode. To prevent condensation, cover the furnace with 1-inch (25mm) foil faced fiberglass insulation or duct board. Be sure to allow access to the control box cover for servicing (Figure 9). Tape all seams with UL 181-A-P aluminum tape.

Insulate exterior cabinet except the control panel in high humidity areas with a minimum of 1.0" [25mm] thick fiberglass or foam rubber



**Figure 9. High humidity applications.**

**WIRING**

**WARNING!**

**DISCONNECT ELECTRICAL SUPPLY BEFORE WIRING UNIT TO PREVENT INJURY OR DEATH FROM ELECTRICAL SHOCK.**

All electrical wiring must comply with all local codes and ordinances.

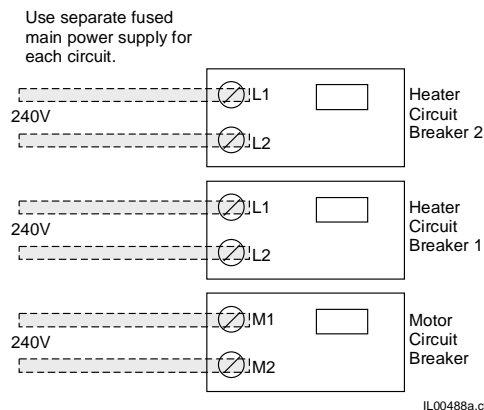
Connect power supply to a main disconnect per local codes. The power connects to the line input terminals as shown on the electrical wiring diagrams. For single phase these are labeled: L1, L2 and for three phase these are labeled: L1, L2, L3. Refer to the label on the control box lid for specific wire sizes and amperage. Connect a ground wire to the ground lug labeled G.

**CAUTION**

**TO PREVENT FIRE AND OTHER ELECTRICAL HAZARDS, ALL WIRING MUST HAVE PROPERLY SIZED OVERCURRENT PROTECTION.**

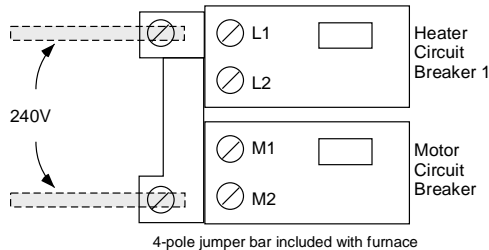
Note: The circuit breakers installed in this device provide short-circuit protection of internal wiring and DO NOT provide over current protection of the supply wiring.

**Separate power supply.** The electric furnace is equipped with several circuit breakers, including a circuit breaker for the blower (M1, M2). The blower circuit breaker provides a convenient disconnect for the blower motor for service. For single phase furnaces the blower circuit breaker is separate from the heater circuit breakers. Turning off the heater circuit breaker will not disconnect the blower power. For three phase furnaces, the blower circuit breaker is in line with the heater circuit breaker. Turning off the heater will shut off the motor.



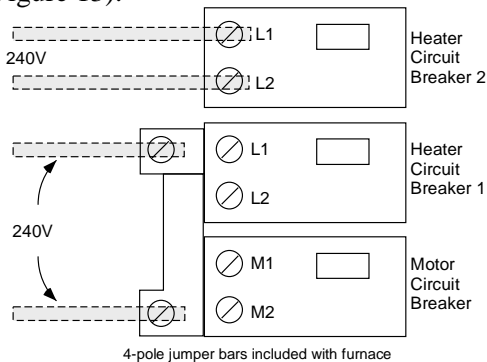
**Figure 10. Separate heater and motor circuits**

**Combining the motor and heater loads (single phase heaters only).** All single phase furnaces include a 4-pole jumper bar (P/N: A01241-001) to combine the blower motor circuit breaker and one of the heater circuit breakers (Figure 11). The combined load can be powered by one fused main circuit sized for both the heater and motor loads. Remove the jumper bars if using a separate power supply for motor and electric furnace as in Figure 10.

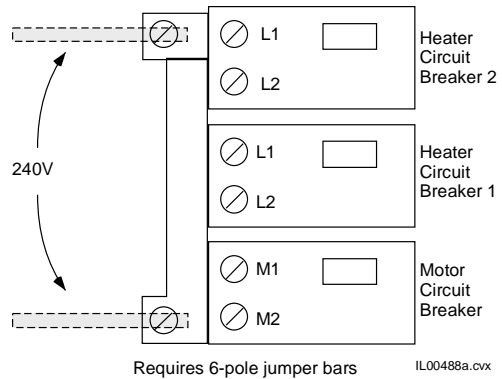


**Figure 11. Combined blower motor and one heater circuit wiring (single phase furnaces only) (10kW and below)**

The 15 and 20 kW single phase heaters have two heater circuit breakers because most residential codes limit circuit sizes to 60 amps. To combine one of the heater circuits and the motor circuit similar to the 10kw, use the 4-pole jumper bar included (Figure 12). Use an optional 6-pole jumper bar (P/N: A01241-002) to combine all the circuit breakers into one large circuit (Figure 13).



**Figure 12. Combined one heater circuit and motor circuit with 4-pole jumper bar. (15 and 20 kW single phase furnaces only) (Option 1)**

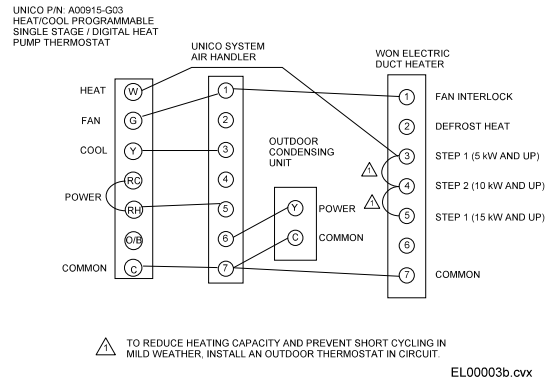


**Figure 13. Single power supply (15 and 20 kW single phase furnaces only) (Option 2)**

**Blower control box mounting.** When using a *Unico* electric furnace, mount the blower control box on top of the blower cabinet or to a remote location near the blower module.

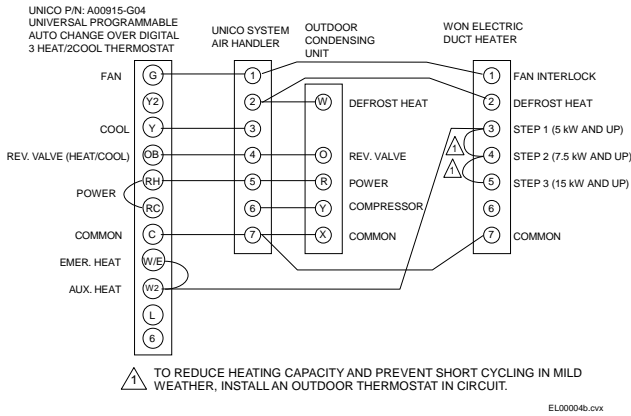
**Control wiring.** The electric furnace is controlled with 24Vac control signals. The furnace has one, two, or three stages (steps) of heat. These can be combined with a jumper wire if desired. Refer to the blower motor instructions for information on how to connect an electric furnace to the blower motor control. The method of connection will vary for different models of blowers. Figures 14-16 are examples.

CONTROL WIRING DIAGRAM FOR COOLING ONLY UNICO SYSTEM WITH ELECTRIC HEAT



**Figure 14. Control Wiring Diagram for Heating-Only or Cooling/Heating Applications**

CONTROL WIRING DIAGRAM FOR UNICO HEAT PUMP WITH WON ELECTRIC DUCT HEATER



**Figure 15. Control Wiring Diagram for Heat Pump Applications**

All furnaces below 20 kW are internally wired to provide 5 kW of defrost heat. The 20 kW furnace provides 10 kW of defrost heat. If 10 kW of heating during defrost is desired for the smaller kW furnaces, contact the Unico Engineering Office for instructions. It is important to use a thermostat designed for use with electric heat because a normal HEAT-COOL thermostat will not energize the fan. Thermostats designed for heat pump systems will also work. Match thermostat anticipator settings for combined amperage load of all components, including electric furnace contactors, to prevent damage to thermostat. The internal wiring diagrams are shown in Figures 18 through 22.

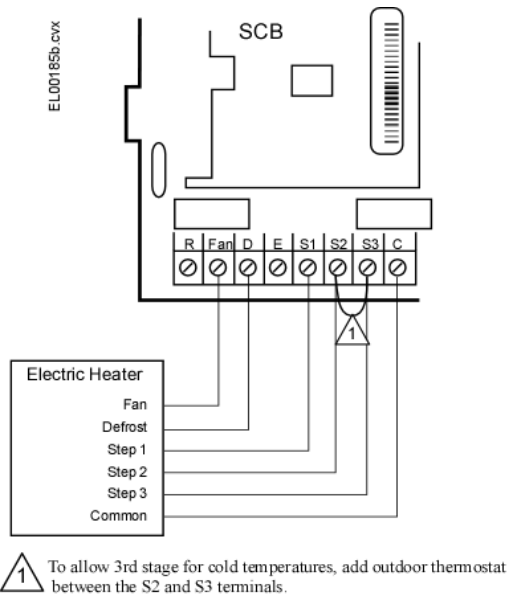
**SPECIAL WIRING FOR HEAT PUMPS**

When using a heat pump coil it may be necessary to install an outdoor thermostat because the entering air is set at 70°F (21°C) and the heater has an auto limit set at 165°F (73°C). The outdoor thermostat will prevent short-cycling of the heater auto limit due to high temperature air and will energize the 3<sup>rd</sup> stage. Refer to Table 2 to determine if your system requires an outdoor thermostat.

**Table 2. When to use outdoor thermostat for last stage furnaces**

| Airflow<br>CFM (m <sup>3</sup> /s) | kW Rating of Electric Furnaces                     |   |     |     |     |     |
|------------------------------------|--|---|-----|-----|-----|-----|
|                                    | 2  | 5 | 7.5 | 10  | 15  | 20  |
| 200 (.09)                          |  |   | N/A | N/A | N/A | N/A |
| 300 (.14)                          |  |   | N/A | N/A | N/A | N/A |
| 400 (.19)                          |  |   |     | N/A | N/A | N/A |
| 500 (.24)                          |  |   |     |     | N/A | N/A |
| 600 (.28)                          |  |   |     |     |     | N/A |
| 700 (.33)                          |  |   |     |     |     | N/A |
| 800 (.38)                          |  |   |     |     |     |     |
| 900 (.42)                          |  |   |     |     |     |     |
| 1000 (.47)                         |  |   |     |     |     |     |
| 1250 (.59)                         |  |   |     |     |     |     |
|                                    | Outdoor thermostat not required                    |   |     |     |     |     |
|                                    | Use outdoor thermostat to limit last stage element |   |     |     |     |     |

For units using the *Unico Smart Control Board (SCB)*, no outdoor thermostats are required. The *Unico SCB* will lock out the third stage of the electric furnace when the heat pump is on.



**Figure 16. Control Wiring to the SCB**

**SEQUENCE OF OPERATION**

All furnaces have a built-in delay feature to delay the furnace from coming on before the air handler is operating. There is no delay-off feature. As soon as the thermostat is satisfied, the furnace de-energizes. For the single speed air handlers with PSC motors, the blower will also immediately stop. For the variable speed EC motor and SCB, the air handler will ramp down for 45 seconds. An air pressure switch is in series with the fan interlock relay for added protection and safety. The larger furnaces have multiple stages with time-delay sequencers for a softer start.



### CAPACITY AT LOWER VOLTAGES

The elements are rated at 240 Volts and should not be used at higher voltages. Lower voltages are acceptable. However, furnaces are resistive loads so capacity is reduced by the square of the voltage ratio.

$$\text{kW (output)} = \text{kW (rated)} \times (\text{V}/240)^2$$

Note:  $(\text{V}/240)^2 = \text{Factor}$

Example: For a WON0752-C Model:  $\text{kW (output)} = 7.2 \times (230/240)^2$   
 $\text{kW (output)} = 6.6\text{kW}$

Therefore, multiply the rated capacity shown in Table 4 by the factor shown in Table 3 to determine the actual output of the furnace at other voltages.

**Table 3. Furnace Capacity Factor at other voltages**

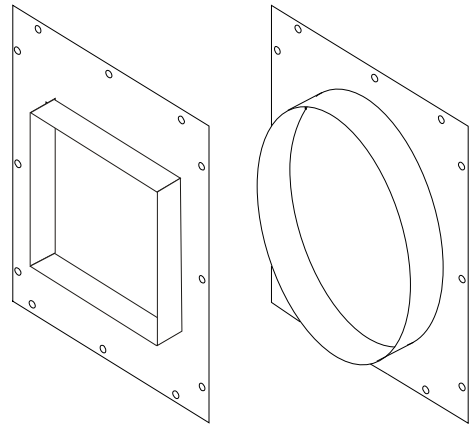
| Voltage | Factor |
|---------|--------|
| 240     | 1.00   |
| 230     | 0.92   |
| 220     | 0.84   |
| 208     | 0.75   |
| 200     | 0.69   |

**Table 4. Rated Capacity for WON heaters**

| Model     | L inch | Rated Capacity kW @240V | Amperage @ 240V |
|-----------|--------|-------------------------|-----------------|
| WON0202-C | 13     | 2.0                     | 8.30            |
| WON0502-C | 13     | 4.8                     | 20.00           |
| WON0752-C | 16     | 7.2                     | 31.25           |
| WON1002-C | 16     | 9.6                     | 40.00           |
| WON1502-C | 21     | 14.4                    | 60.00           |
| WON2002-C | 24     | 19.2                    | 80.00           |
| WON0504-C | 21     | 4.8                     | 11.54           |
| WON0754-C | 21     | 7.2                     | 18.04           |
| WON1004-C | 21     | 9.6                     | 23.09           |
| WON1504-C | 21     | 14.4                    | 34.64           |

### OPTIONAL ADAPTERS AND SPARE PARTS

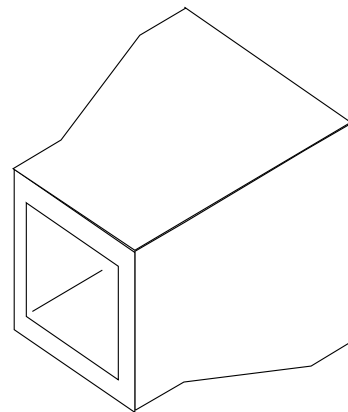
Tables 5 and 6 provide a list of optional plenum adapters available for the electric furnace. Spare parts are also listed in Table 8 and can be ordered using the part numbers shown.



**Table 5. Plenum Adapters (Optional)**

| A Size                   | Part Number  |
|--------------------------|--------------|
| 7-inch [178 mm] Round    | A01007-001   |
| 9-inch [228 mm] Round    | A01007-002   |
| 10-inch [254 mm] Round   | A01007-003 * |
| 6.5-inch [165 mm] Square | A01008-001   |
| 8.5-inch [216 mm] Square | A01008-002   |
| 9.5-inch [241 mm] Square | A01008-003 * |

\*Included with unit



**Table 6. 1 inch (25 mm) Fiberglass Square Reducers (Optional)**

| Part No.     | Square Size                     |
|--------------|---------------------------------|
| UPC-29-9585S | 9.5 to 8.5 inch [241 to 216 mm] |
| UPC-29-9565S | 9.5 to 6.5 inch [241 to 165 mm] |
| UPC-29-8565S | 8.5 to 6.5 inch [241 to 216 mm] |

## DUCT DESIGN

The design of the duct system must account for the added restriction of the furnace. Table 5 lists the static pressure drop of the furnaces. Usually it will be necessary to add additional outlets to account for the added restriction, particularly for the systems requiring more than 800 CFM (378 L/s). For these systems it is not unusual to have 7 outlets per ton.

**Table 7. Pressure drop, inches of water (Pa)**

|        |        | Air Handler Airflow Range | Electric Duct Heater Models |                    |                     |                     |                     |                     |
|--------|--------|---------------------------|-----------------------------|--------------------|---------------------|---------------------|---------------------|---------------------|
|        |        | CFM (L/s)                 | 2kW                         | 5kW                | 7.5kW               | 10kW                | 15kW                | 20kW                |
| U1218  |        | 150 (71)                  | <b>0.04</b> (10.0)          | <b>0.06</b> (14.9) | <b>0.04</b> (10.0)  |                     |                     |                     |
|        |        | 200 (94)                  | <b>0.07</b> (17.4)          | <b>0.11</b> (27.4) | <b>0.08</b> (19.9)  |                     |                     |                     |
|        |        | 250 (118)                 | <b>0.11</b> (27.4)          | <b>0.17</b> (42.3) | <b>0.12</b> (29.9)  |                     |                     |                     |
|        |        | 300 (142)                 | <b>0.16</b> (39.8)          | <b>0.24</b> (59.8) | <b>0.18</b> (44.8)  |                     |                     |                     |
|        |        | 350 (165)                 | <b>0.21</b> (52.3)          | <b>0.32</b> (79.7) | <b>0.24</b> (59.8)  |                     |                     |                     |
| M2430B | M3036B | 400 (189)                 |                             | <b>0.14</b> (34.9) | <b>0.18</b> (44.8)  | <b>0.19</b> (47.3)  |                     |                     |
|        |        | 450 (212)                 |                             | <b>0.17</b> (42.3) | <b>0.21</b> (52.3)  | <b>0.23</b> (57.3)  |                     |                     |
|        |        | 500 (236)                 |                             | <b>0.20</b> (49.8) | <b>0.25</b> (62.3)  | <b>0.27</b> (67.2)  |                     |                     |
|        |        | 550 (260)                 |                             | <b>0.23</b> (57.3) | <b>0.29</b> (72.2)  | <b>0.31</b> (77.2)  |                     |                     |
|        |        | 600 (283)                 |                             | <b>0.27</b> (67.2) | <b>0.33</b> (82.2)  | <b>0.35</b> (87.2)  | <b>0.47</b> (117.0) |                     |
|        |        | 650 (307)                 |                             | <b>0.30</b> (74.7) | <b>0.37</b> (92.1)  | <b>0.39</b> (97.1)  | <b>0.53</b> (132.0) |                     |
|        |        | 700 (330)                 |                             | <b>0.33</b> (82.2) | <b>0.41</b> (102.1) | <b>0.44</b> (109.6) | <b>0.59</b> (146.9) |                     |
| M4860B | M3642B | 750 (354)                 |                             | <b>0.15</b> (37.4) | -                   | <b>0.26</b> (64.7)  | <b>0.35</b> (87.2)  |                     |
|        |        | 800 (378)                 |                             | <b>0.16</b> (39.8) | -                   | <b>0.28</b> (69.7)  | <b>0.38</b> (94.6)  | <b>0.48</b> (119.5) |
|        |        | 850 (401)                 |                             | <b>0.17</b> (42.3) | -                   | <b>0.30</b> (74.7)  | <b>0.41</b> (102.1) | <b>0.51</b> (127.0) |
|        |        | 900 (423)                 |                             | <b>0.19</b> (47.3) | -                   | <b>0.32</b> (79.7)  | <b>0.44</b> (109.6) | <b>0.55</b> (137.0) |
|        |        | 950 (448)                 |                             | <b>0.20</b> (49.8) | -                   | <b>0.35</b> (87.2)  | <b>0.47</b> (117.0) | <b>0.59</b> (146.9) |
|        |        | 1000 (472)                |                             | <b>0.21</b> (52.3) | -                   | <b>0.37</b> (92.1)  | <b>0.5</b> (124.5)  | <b>0.63</b> (156.9) |
|        |        | 1050 (496)                |                             | <b>0.23</b> (57.3) | -                   | <b>0.39</b> (97.1)  | <b>0.53</b> (132.0) | <b>0.68</b> (169.3) |
|        |        | 1100 (519)                |                             | <b>0.24</b> (59.8) | -                   | <b>0.42</b> (104.6) | <b>0.57</b> (141.9) | <b>0.71</b> (176.8) |
|        |        | 1150 (543)                |                             | <b>0.26</b> (64.7) | -                   | <b>0.44</b> (109.6) | <b>0.60</b> (149.4) | <b>0.75</b> (186.8) |
|        |        | 1200 (566)                |                             | <b>0.27</b> (67.2) | -                   | <b>0.47</b> (117.0) | <b>0.63</b> (156.9) | <b>0.80</b> (199.2) |
|        |        | 1250 (590)                |                             | <b>0.28</b> (69.7) | -                   | <b>0.49</b> (122.0) | <b>0.67</b> (166.8) | <b>0.84</b> (209.2) |

**Table 8. Spare parts list**

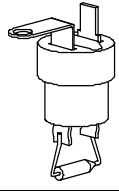
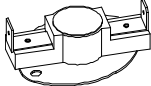
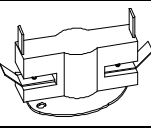
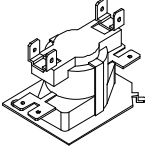
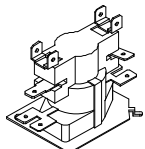
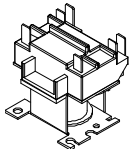
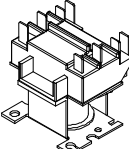
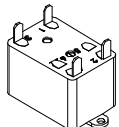
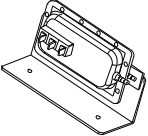
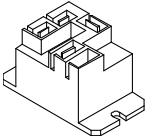
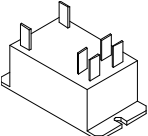
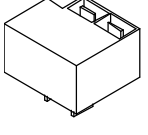
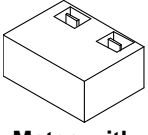
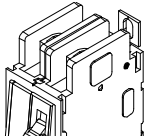
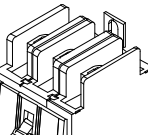
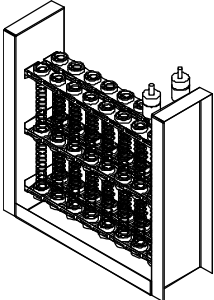
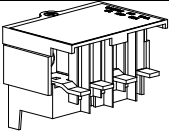
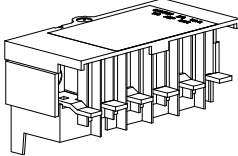
| Drawing   | Part Number | Description              | Revision               | Furnace Model (where used)   |
|---|-------------|--------------------------|------------------------|--|
|    | A00257-001  | Fuse Link, 152°C         | All Revisions          | All WUN models   |
|   | A00257-002  | Fuse Link, 121°C         | All Revisions          | All WON models   |
|    | A01011-001  | Auto-Limit, L145         | All Revisions          | All WON models   |
|   | A01011-004  | Auto-Limit, L165, 1-pole | All Revisions          | WON0202, WON0502, WON1502, WON0504, WON0754, WON1004, WON1504          |
|    | A01011-002  | Auto-Limit, L165, 2-pole | All Revisions          | WON0752, WON1002, WON1502, WON2002, WON0504, WON0754, WON1004, WON1504 |
|    | A01012-001  | Sequencer, 1-pole        | Original (No Revision) | WON0502, WON1502, WON0504, WON0754, WON1004                            |
|    | A01012-002  | Sequencer, 2-pole        | Original (No Revision) | WON0752, WON1002, WON1502, WON2002, WON1504                            |
|  | A01013-001  | Contactor, 1-pole        | All Revisions          | WON0202, WON0502, WON0752, WON1002, WON1502, WON2002, WON1504          |
|  | A01013-002  | Contactor, 2-pole        | All Revisions          | WON2002, WON0504, WON0754, WON1004, WON1504                            |
|  | A00302-003  | Fan Interlock Relay      | All Revisions          | All WON models   |

Table 8 (cont.). Spare parts list

| Drawing  | Part Number                      | Description                                      | Revision                 | Furnace Model (where used)  |
|--|----------------------------------|--|--------------------------|---|
|                                   | A01673-001                       | Air Pressure Switch                              | All Revisions            | All WON models  |
|                                   | A01484-001                       | Relay, DC, 1-pole<br>(Requires A01485 rectifier) | A, B, C                  | WON0202-A/B/C, WON0502-A/B/C, WON1502-A/B/C, WON2002-A/B/C, WON0504-A/B/C, WON0754-A/B/C, WON1004-A/B/C |
|                                   | A01484-002                       | Relay, DC, 2-pole<br>(Requires A02141 rectifier) | C                        | All WON models  |
|  |                                  |  | A, B                     | WON0752-A/B, WON1002-A/B, WON1502-A/B, WON2002-A/B, WON1504-A/B   |
| <b>Mates with A01484-001</b><br>  | A01485-001                       | Rectifier, 5-sec, 3/16" (CRR9-5)                 | C                        | All WON models  |
|  |                                  |  | A, B                     | WON0202-A/B, WON0502-A/B, WON0504-A/B, WON0754-A/B, WON1004-A/B   |
|  | A01485-003                       | Rectifier, 9-second (CRR9-9)                     | A, B                     | WON1502-A/B, WON2002-A/B  |
| <br><b>Mates with A01484-002</b> | A02141-001 (formerly A01485-002) | Rectifier, 5-sec, 1/4", (CRR8-5)                 | C                        | All WON models  |
|  |                                  |  | A, B                     | WON0752-A/B, WON1002-A/B, WON1502-A/B, WON2002-A/B, WON1504-A/B   |
|  | A02141-003                       | Rectifier, 9-sec (CRR8-9)                        | C                        | WON0752-C, WON1002-C, WON1502-C, WON2002-C  |
|  | A02141-005                       | Rectifier, 18-sec (CRR8-18)                      | C                        | WON1502-C, WON2002-C  |
|                                 | A01051-215                       | Circuit Breaker, 2-pole, 15A                     | All Revisions            | All WON models  |
|  | A01051-220                       | Circuit Breaker, 2-pole, 20A                     | Original, A, B           | WON0202   |
|  | A01051-225                       | Circuit Breaker, 2-pole, 25A                     | C                        | WON0502-C   |
|  | A01051-230                       | Circuit Breaker, 2-pole, 30A                     | C                        | WON1502-C   |
|  | A01051-235                       | Circuit Breaker, 2-pole, 35A                     | Original, A, B           | WON0502, WON0502-A/B  |
|  | A01051-240                       | Circuit Breaker, 2-pole, 40A                     | C                        | WON0752-C   |
|  | A01051-250                       | Circuit Breaker, 2-pole, 50A                     | C                        | WON2002-C   |
|  |                                  |  | A, B                     | WON1002-A/B   |
| A01051-260   | Circuit Breaker, 2-pole, 60A     | A, B   | WON1002-A/B, WON2002-A/B |   |
|                                 | A01051-325                       | Circuit Breaker, 3-pole, 25A                     | Original (No Revision)   | WON0504   |
|  | A01051-335                       | Circuit Breaker, 3-pole, 35A                     | Original (No Revision)   | WON0754   |
|  | A01051-340                       | Circuit Breaker, 3-pole, 35A                     | Original (No Revision)   | WON1004   |
|  | A01051-360                       | Circuit Breaker, 3-pole, 35A                     | Original (No Revision)   | WON1504   |

**Table 8 (cont.). Spare parts list**

| Drawing   | Part Number | Description                      | Revision               | Furnace Model (where used)   |
|---|-------------|----------------------------------|------------------------|--|
| <p>Note: Single Element Section part numbers shown. Full Complete Stack's not listed</p>  <p>IL00489.cvx</p> | A02401-G01  | Section, Element, Single, 3.75kW | Original (No Revision) | WON0752, WON0752E  |
|   | A02401-G02  | Section, Element, Single, 2.5kW  | Original (No Revision) | WON0757E WON2002, WON2002E   |
|   | A02401-G03  | Section, Element, Single, 3.2kW  | Original (No Revision) | WON1004  |
|   | A02401-G04  | Section, Element, Single, 4.8kW  | Original (No Revision) | WON1502, WON1502, WON2002, WON2002E  |
|   | A02401-G06  | Section, Element, Single, 2.0kW  | A                      | WON0202-A  |
|   | A02401-G07  | Section, Element, Single, 3.75kW | A                      | WON0752-A, WON0752EA   |
|   | A02401-G08  | Section, Element, Single, 4.8kW  | A                      | WON0502-A, WON0502EA, WON1002-A, WON1002EA, WON1502-A, WON1502EA, WON2002-A, WON2002EA   |
|   | A02401-G11  | Section, Element, Single, 2.0kW  | B , C                  | WON0202-B, WON0202-C   |
|   | A02401-G12  | Section, Element, Single, 3.75kW | B , C                  | WON0752-B, WON0752EB, WON0752-C, WON0752EC   |
|   | A02401-G13  | Section, Element, Single, 4.8kW  | B , C                  | WON0502-B, WON0502EB, WON1002-B, WON1002EB, WON1502-B, WON1502EB, WON2002-B, WON2002EB, WON0502-C, WON0502EC, WON1002-C, WON1002EC, WON1502-C, WON1502EC, WON2002-C, WON2002EC |
|    | A01241-001  | Jumper Bar, 4-pole               | C                      | All WON models   |
|    | A01241-002  | Jumper Bar, 6-pole               | C                      | WON1502-C, WON2002-C   |

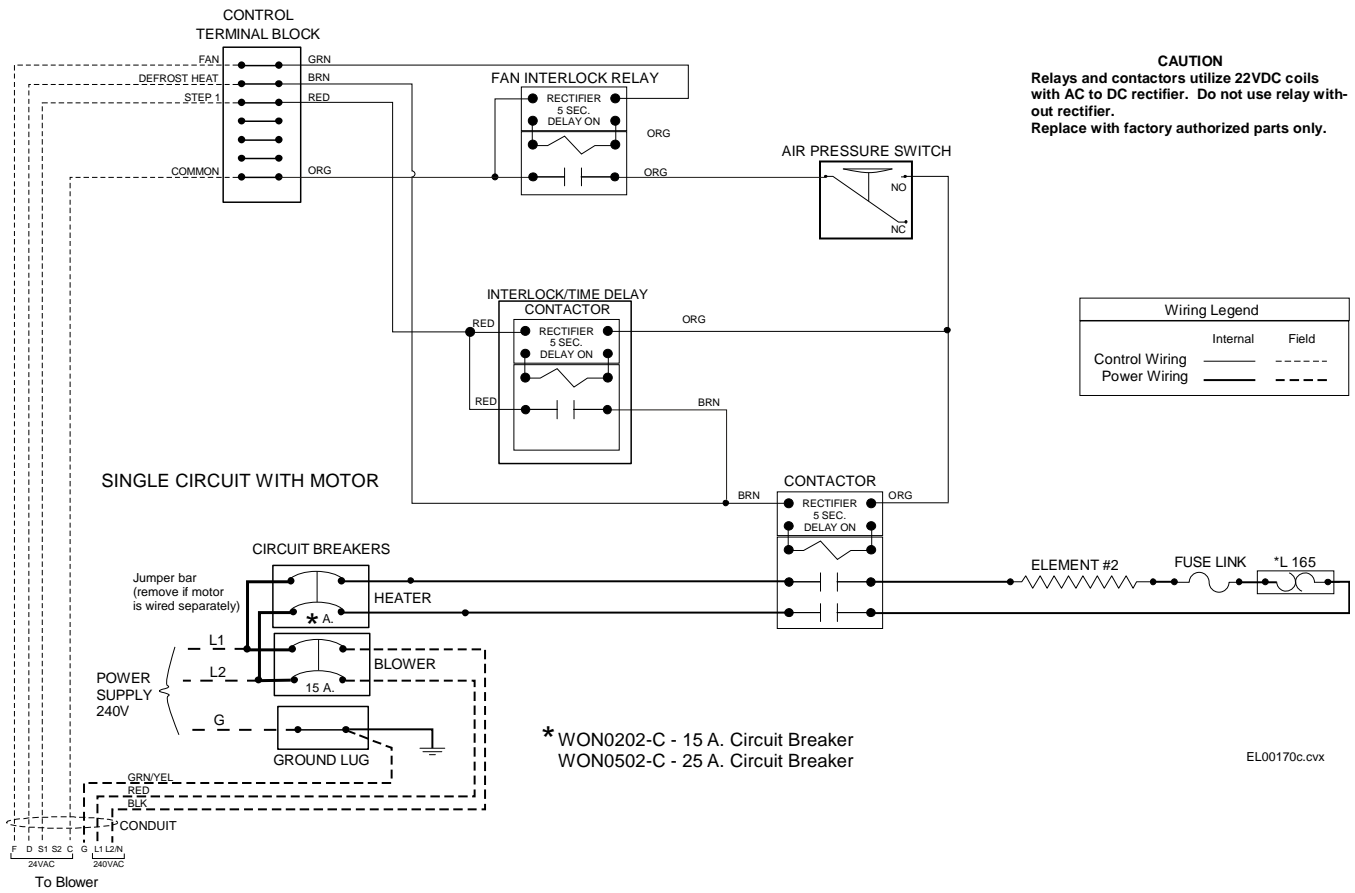


Figure 17. Internal Wiring Diagram for WON0202-C, and WON0502-C. (Single phase)

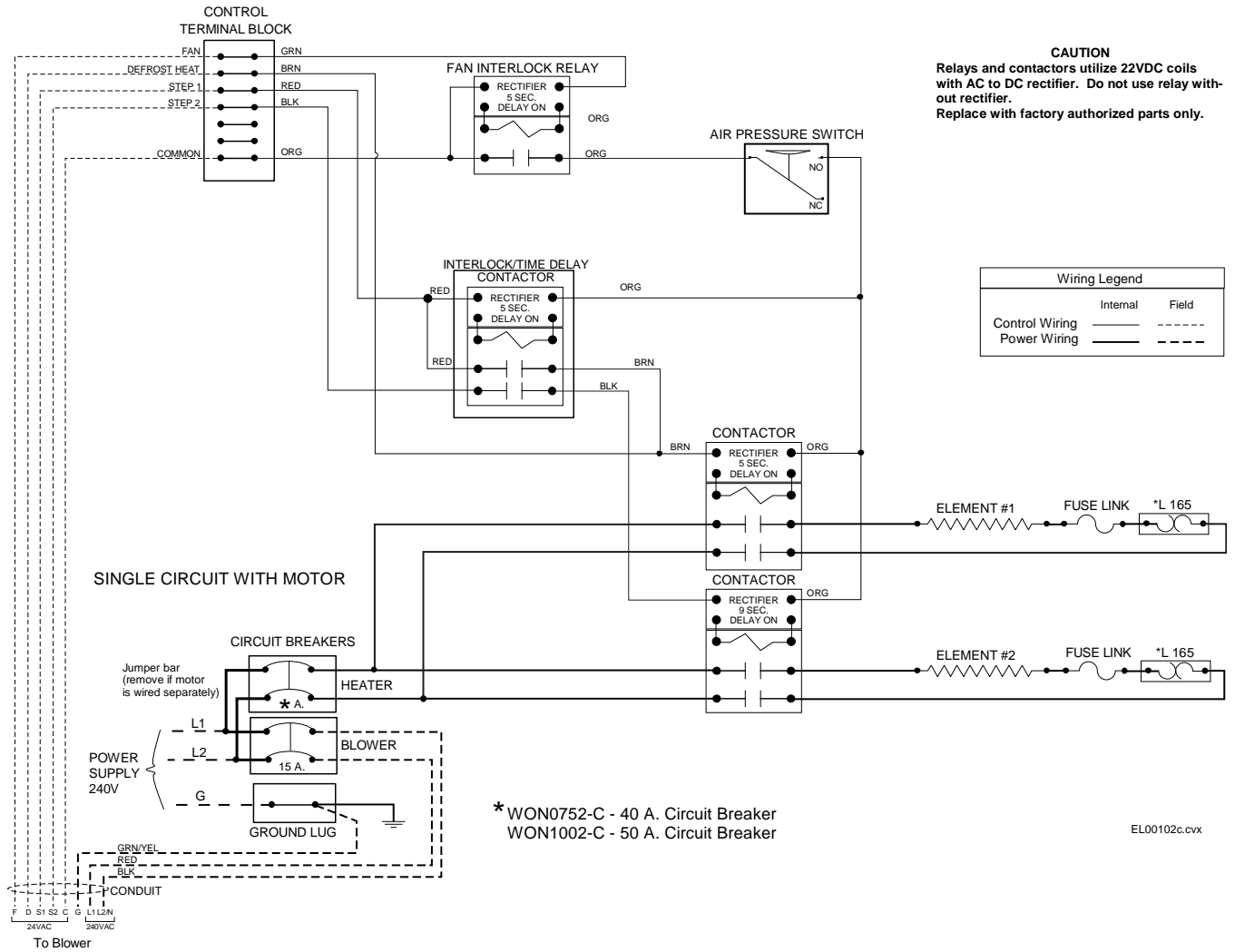


Figure 18. Internal Wiring Diagram for WON0752-C and WON1002-C. (Single phase)

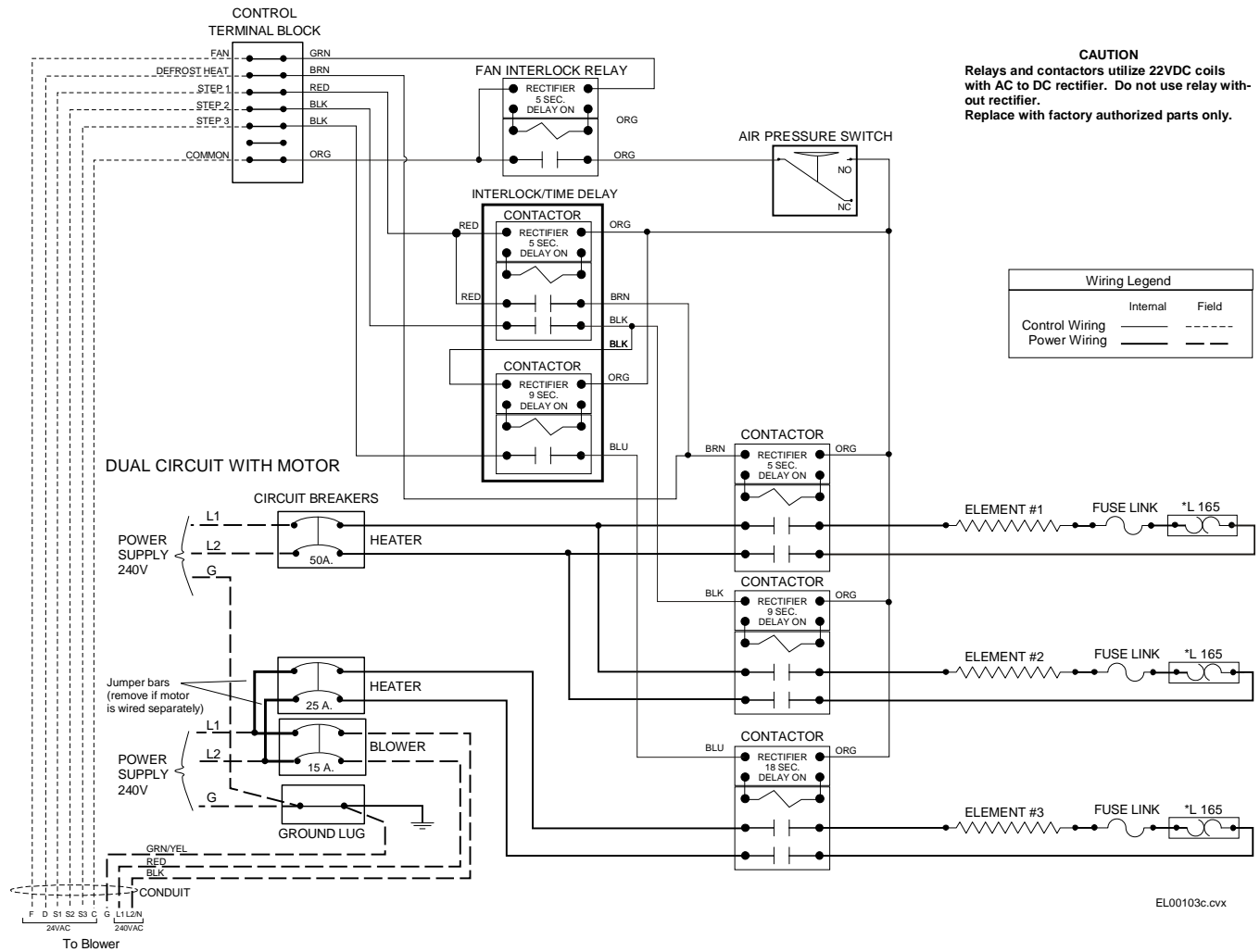


Figure 19. Internal Wiring Diagram for WON1502-C. (Single phase)



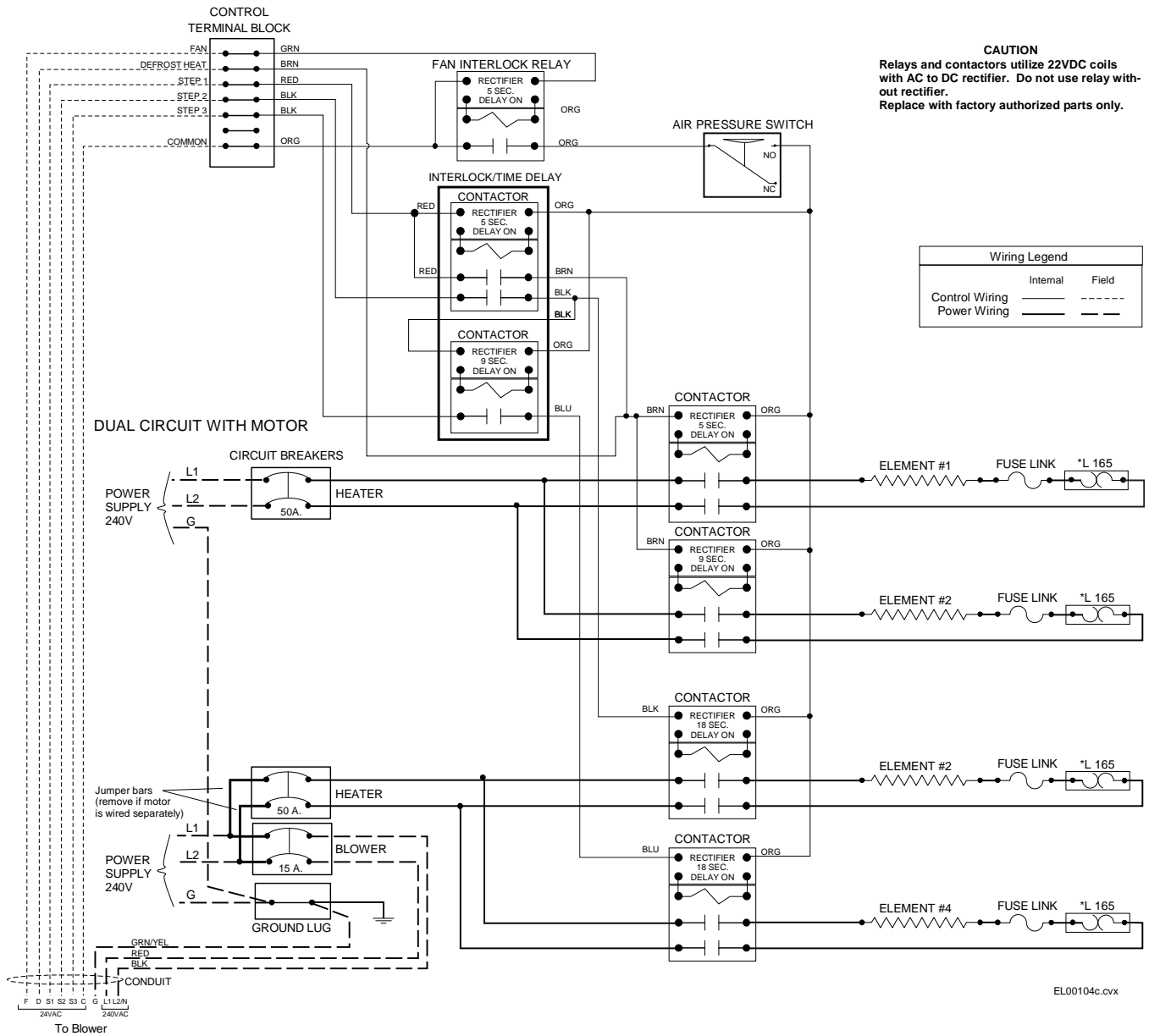
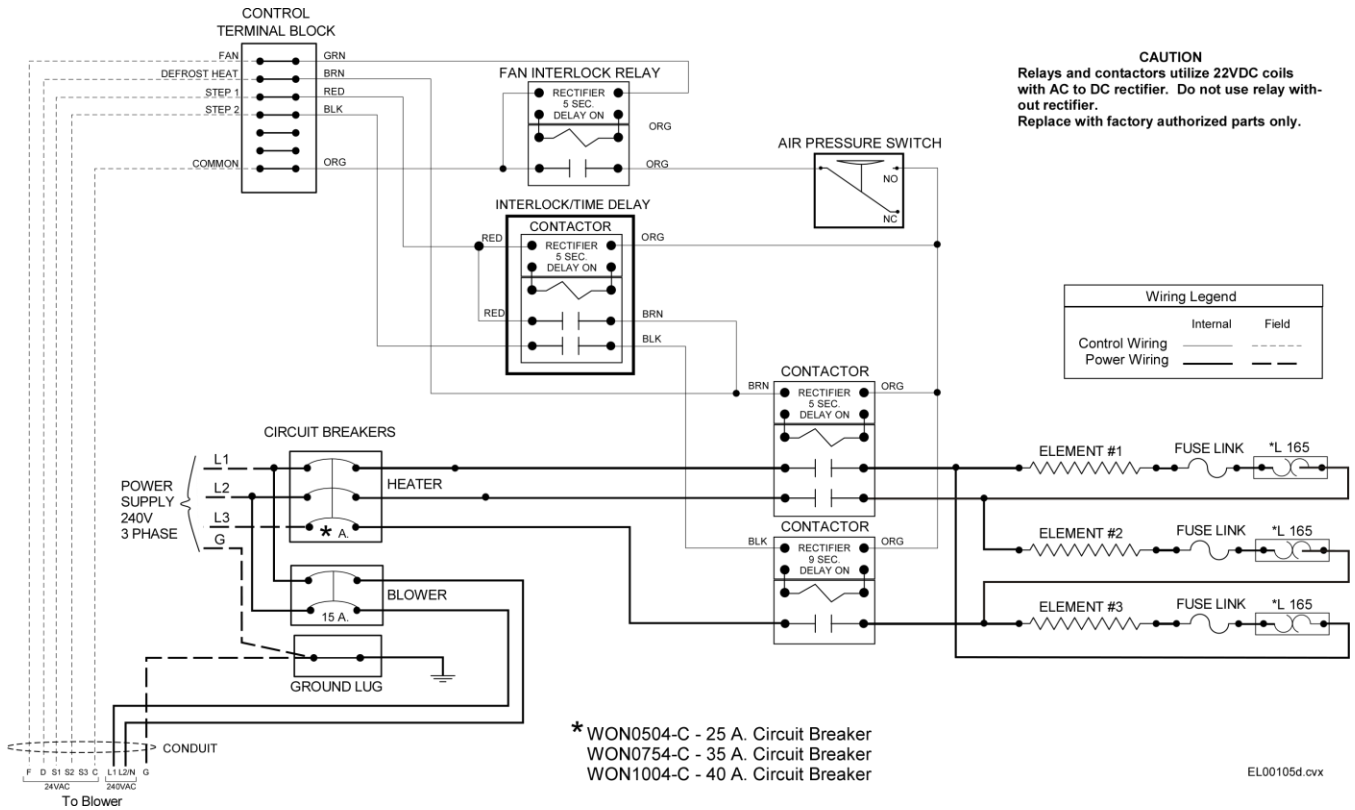
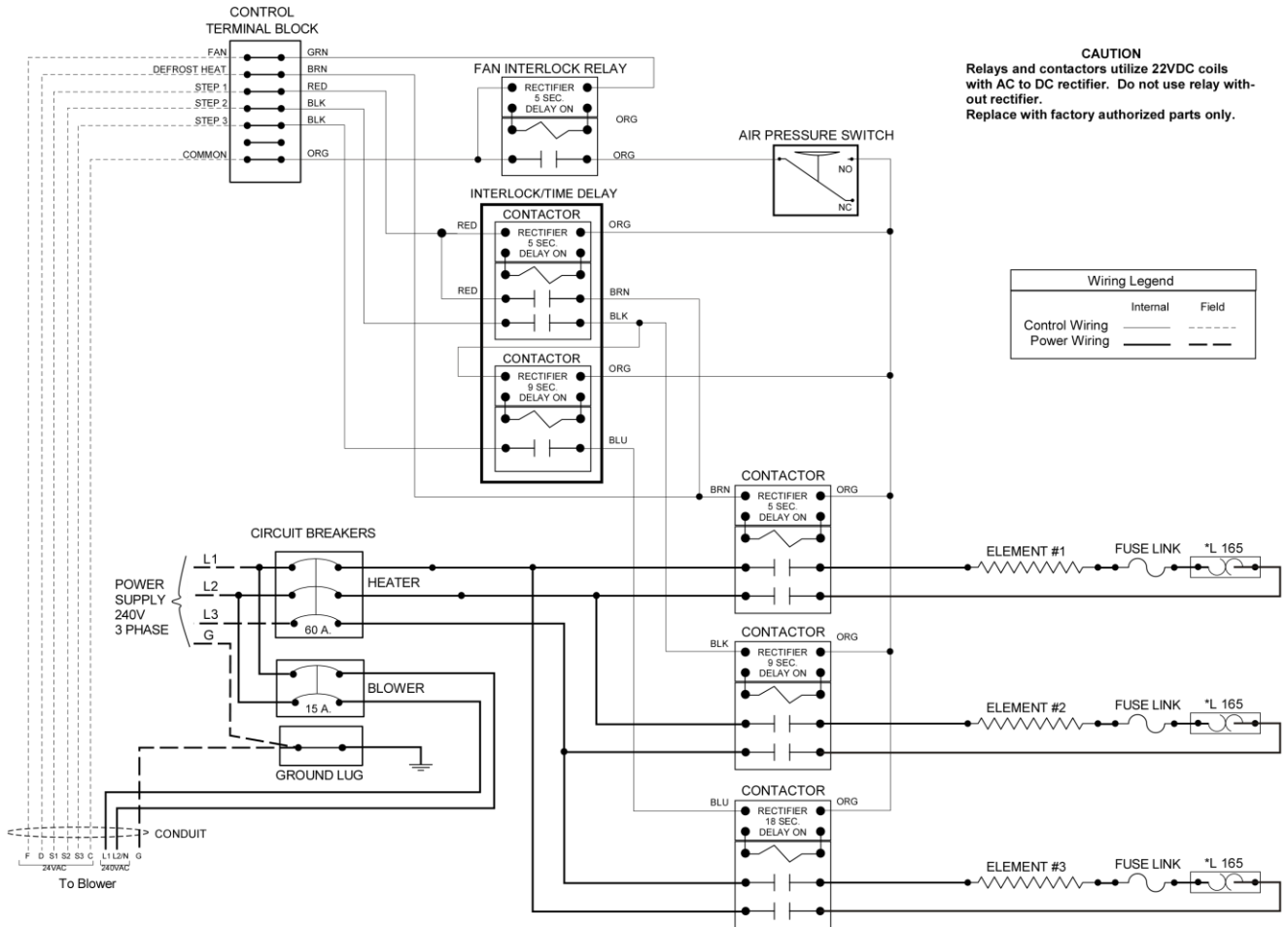


Figure 20. Internal Wiring Diagram for WON2002-C. (Single phase)



**Figure 21. Internal Wiring Diagram for WON0504-C, WON0754-C, and WON1004-C (3 Phase)**



EL00106d.cvx

Figure 22. Internal Wiring Diagram for WON1504-C (3 Phase)