

## WHEN INSTALLING THIS PRODUCT:

1. Read these instructions carefully. Failure to follow instructions can damage product or cause a hazardous condition.
2. Check ratings given in instructions and on product to make sure product is suitable for your application.
3. Make sure installer is a trained, experienced service technician.
4. After completing installation, use these instructions to check out product operation.

**WARNING**

This thermostat is a line voltage (120 to 277 Vac) control. Do not install it unless you are completely familiar and competent with home wiring. If improperly handled there can be a risk of 240 volt electric shock hazard which may cause serious injury or death.

**CAUTION**

1. Disconnect power supply before making wiring connections to prevent electrical shock or equipment damage.
2. All wiring must comply with national and local codes and ordinances.
3. When using aluminum conductors, all wiring connections to this thermostat must be made to the factory installed leadwires using approved CO/ALR solderless connectors. A fire hazard may result otherwise.
4. To avoid handling the sensing element, do not remove thermostat cover until wiring is completed.
5. Thermostats are designed for use with appliances having a limit control.

**New Installations**

1. Install a single-gang electrical box oriented vertically about 4' to 5' (1.5 m) above the floor on an inside wall or pillar where the thermostat will be subjected to typical room temperature.

**NOTE:** To sense temperature properly, the thermostat must be placed away from concealed warm or cold water pipes, air ducts, or drafts from hallways, fireplaces or stairways. Do not place thermostat above convectors or in the flow from supply fans. Ideally, a thermostat should be close to the return air path to effectively measure average room temperature.

2. Wire installation in an approved fashion.

**NOTE:** T651A and T451A do not feature a Positive Off setting, and may not be used as a disconnect switch.

3. Leave cover on the thermostat while making wiring connections. Use solderless connectors approved for the type, number and gauge of wires being joined.

Connect as per Fig. 2 for the appropriate application.

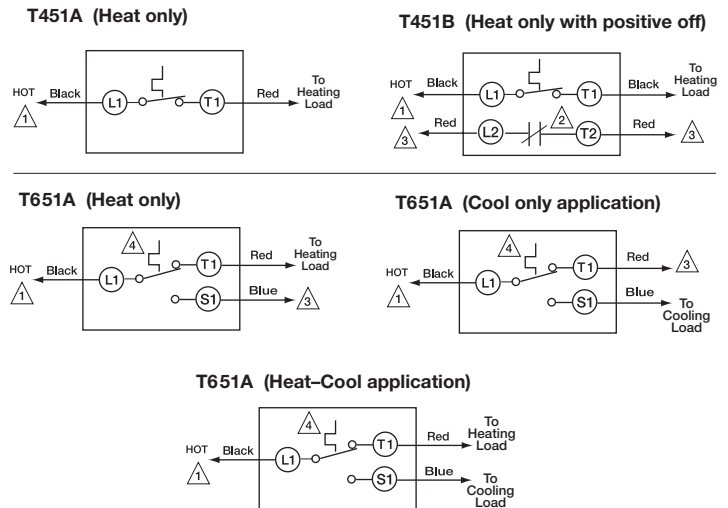
**Fig. 2 — Wiring connections**

1 Power supply; provide disconnect means and overload protection as required.



2 Breaks on Positive Off.



3 Exposed unused wires must be properly insulated.



4 Contact makes Black to Red on temperature fall; Black to Blue on temperature rise.

4. Pre-bend and push leadwires into the electrical junction box.

5. Hold the thermostat base with one hand and remove the thermostat cover by grasping two sides of the cover and pulling outward.

**NOTE:** If locking cover feature is desired, insert the locking cover clip in the thermostat base BEFORE mounting the thermostat on the wall (see Fig. 7).

6. Using the screwdriver, secure the thermostat to the box by tightening the two mounting screws. Handle thermostat with care. Excessive pressure may damage the control knob or sensing element.

**IMPORTANT:** Before mounting the thermostat, turn the setting dial to the mid-position (indicator pointing to the top of the thermostat): this will prevent damage to the dial stop if the dial is accidentally turned by the screw driver when the top mounting screw is tightened. Do NOT press on diaphragm, diaphragm lever arm or setpoint knob to seat thermostat on the box: thermostat will be damaged.

**Replacement Applications**

1. Disconnect power supply before making wiring connections to prevent electrical shocks or equipment damage. All wiring must comply with applicable codes and standards.
2. Remove the old thermostat from the wall, taking care not to damage the wiring insulation.
3. Check the old insulation for cracks, nicks or fraying. Apply certified electrical tape where necessary to insulate wires, or replace the wires in an approved fashion.
4. Complete installation following steps 3 to 6 in the New Installations section.

## Check Out

Turn on power. Raise the temperature setting to energize the heating contact and break the cooling contact. The HVAC equipment should begin heating or stop cooling, as appropriate.

NOTE: For T451A and T651A models only, the thermostat will call for heat (disable cooling) when the setpoint dial is at full counter-clockwise position. This setting is the phase change point of the diaphragm's vapor fill and is independent of calibration. To de-energize the load(s), turn off power at the circuit breaker panel, or add a separate disconnect switch.

## Altitude Compensation

T451, T651 units are calibrated at the factory for accuracy at 500 feet above sea level. No recalibration is needed if the switch operates at the same temperature indicated on the thermometer.

The vapor-filled diaphragm sensor is affected by barometric pressure and altitude. Deviations up to  $\pm 1^\circ\text{F}$  ( $1/2^\circ\text{C}$ ) are within normal operation. Control point drops  $2^\circ\text{F}$  every 1000 ft. ( $1^\circ\text{C}/300$  m) above sea level. See Fig. 3 for recommended action.

Fig. 3 — Altitude Correction

Elevation (in feet)	Typical City	Recommended Action
0 to 2000	Toronto, Ontario Phoenix, Arizona	Leave as is
2000 to 4000	Las Vegas, Nevada Calgary, Alberta	Move clockwise 2 to 3 marks
4000 to 6000	Denver, Colorado Salt Lake City, Utah	Move clockwise 4 to 5 marks

### To Recalibrate

1. Remove cover. Set the tab on setpoint knob to the leftmost radial mark visible on top of the triangular arm that holds the dual diaphragm sensor (Fig. 4).
2. *Without rotating the knob*, remove it from the thermostat by pulling straight out, while holding the base against the wall.
3. Now, rotate the removed setpoint knob clockwise by the amount of temperature error. Each mark on the triangular arm represents  $2^\circ\text{F}$  ( $1^\circ\text{C}$ ) of adjustment. Snap the knob back onto the setpoint cam.

4. Install the cover. Wait five minutes to let the thermostat thermally stabilize and re-check calibration.  
*Do not assume a thermostat is out of calibration until it has been installed and allowed to operate for several hours.*

Fig. 4 — Recalibrating Thermostat

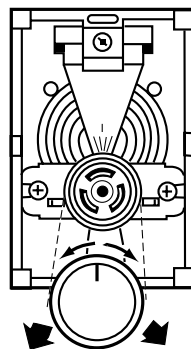
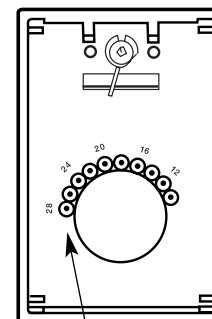

Fig. 5 — Installing Range Stops



Insert pins into temperature stop positions

## Security Features:

### Range Stops

1. Set thermostat to desired setpoint. Remove cover.
2. Install plastic dowels supplied (or purchased separately) into minimum and/or maximum range stop holes on inside back of cover (Fig. 5).
3. Re-install cover. Check operation of range stops.

Fig. 6 — Cover Locking Kit

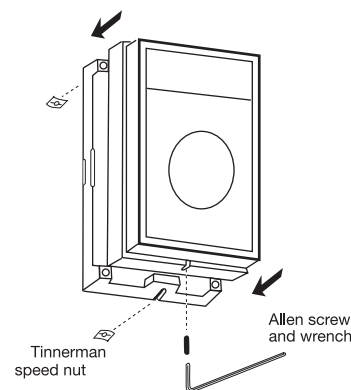

### Locking Cover

1. Remove cover by pulling straight out.
2. Insert Tinnerman Speed Nut<sup>®</sup>s into slots top and bottom of thermostat base.
- 3 Drive Allen screw into Speed Nut until head is flush with outside edge of thermostat base.
4. Re-install cover. Lock by *backing out* Allen screw until screw body protrudes through cover hole. To unlock cover, drive Allen screw *into* thermostat base.

Home and Building Control  
Honeywell Inc.  
1985 Douglas Drive North  
Golden Valley, MN 55422

Home and Building Control  
Honeywell Limited-Limitée  
35 Dynamic Drive  
Toronto, ON M1V 4Z9

**Honeywell**