



SYMMONS® Hydapipe®

1-801 Series (standard)
1-802 Series (short)

INSTALLATION INSTRUCTIONS

Product meets ANSI A112.18.1M
 Flow rate: 2.5 gpm (9.5 L/min)

Drilling pattern for valve and piping assembly

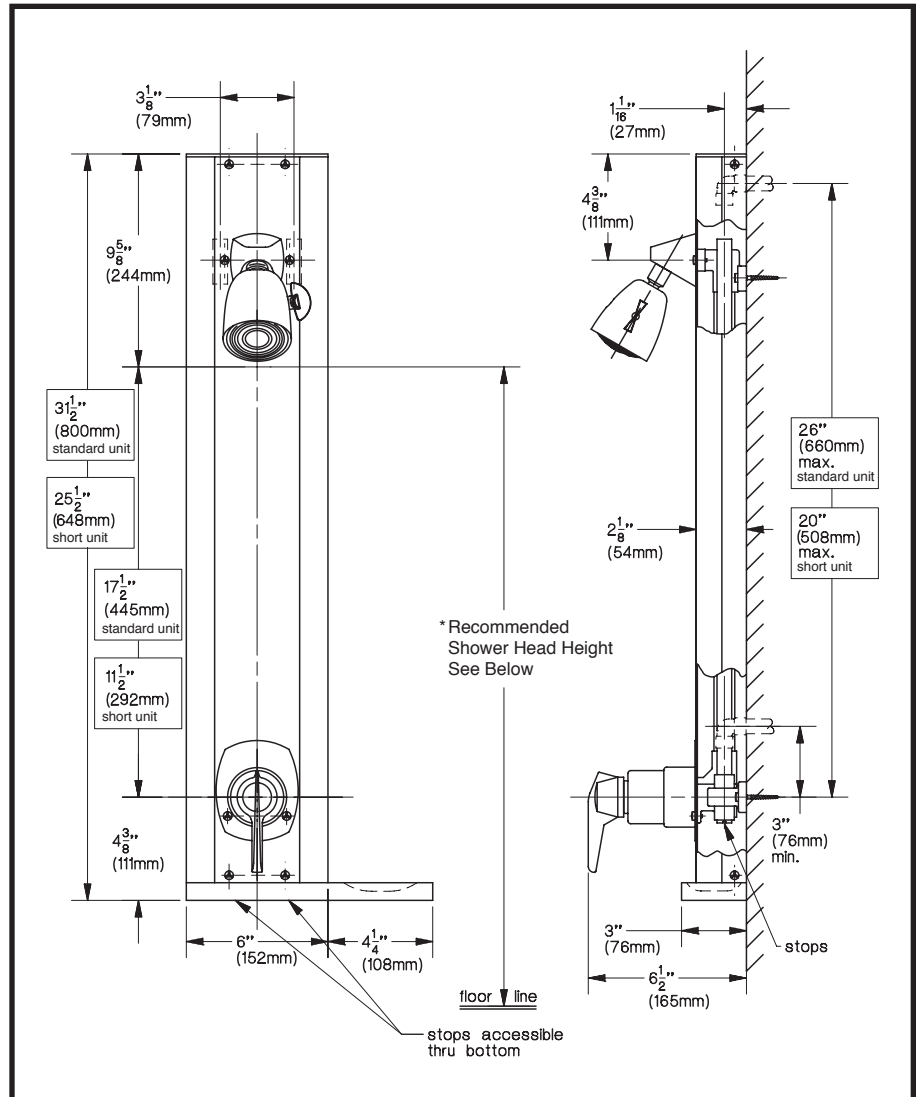
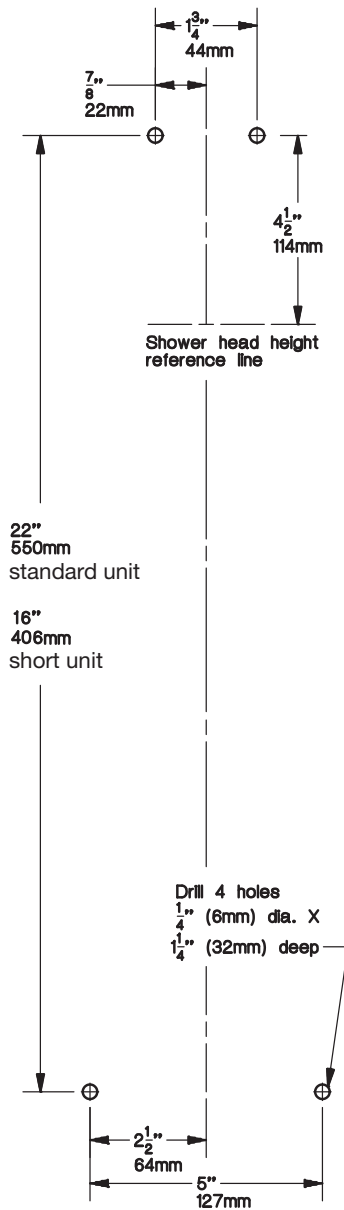

Recommended head heights

Men	6'0"
Boys, Senior High	5'10"
Boys, Junior High	5'7"
Boys, Elementary	5'4"
Women	5'8"
Girls, Senior High	5'8"
Girls, Junior High	5'5"
Girls, Elementary	4'2"

INSTALLATION:

1. With special wrench provided remove four vandal-proof screws holding stainless steel unit cover to valve and piping assembly (two screws at head bracket and two screws at valve). Remove unit cover. Note: head bracket is fastened to unit cover and is removed with it.
2. Mount valve and piping assembly to wall with screws and anchors provided. Connect supply piping.
3. Replace unit covering and fasten with vandal proof screws.
4. Install shower head.

For ADA compliance (Americans with Disabilities Act) consult ADAAG or your state regulations for proper product choice and mounting heights. ADAAG does permit a fixed shower head mounted 48" above the floor in unmonitored facilities where vandalism may be a problem.

INDIVIDUAL PARTS		INDIVIDUAL PARTS		COMPOSITE PARTS	
C-13	Dome cover	SC-13C	Dial	C-5	Spindle assembly
HP-2	Shield (standard unit)	SC-15A	Set screw	C-50	Renewable seat socket wrench
HP-3	Shield (short unit)	SC-18	Lock nut	KIT-B	Washer and gasket kit
HP-4	Top cap	S2H-8D	Set screw	SC-2	Cap assembly
HP-5	Soap dish	SC-3	Renewable seat	SC-3	Renewable seat unit complete
HP-6	Nameplate	SC-7	Packing nut	HP-17ASB	Stop assembly
HP-7	Screw	SC-9	Cold washer retainer		
HP-8	Shower head bracket	SC-10	Hot washer		
HP-10	Body cover	SC-10A	Screws		
HP-10A	O-ring	SC-11	Cold washer		
HP-14	Screw	SC-17	Packing		
HP-14A	Washer	SC-19	Cap gasket		
HP-14B	Star plastic anchors	SC-26	Limit stop with o-ring		
HY-1A	Piping assembly (standard unit)	4-231M	Super shower head		
HY-1B	Piping assembly (short unit)				
J-32B	O-ring				
RC-14	Handle				

Tools required for installation:

Slotted screwdriver, Phillips screwdriver, soldering equipment, adjustable wrench, channel lock pliers, hex socket keys (1/8" and 3/32"), electric drill with 1/4" drill bit, HY-50 screwdriver (provided)

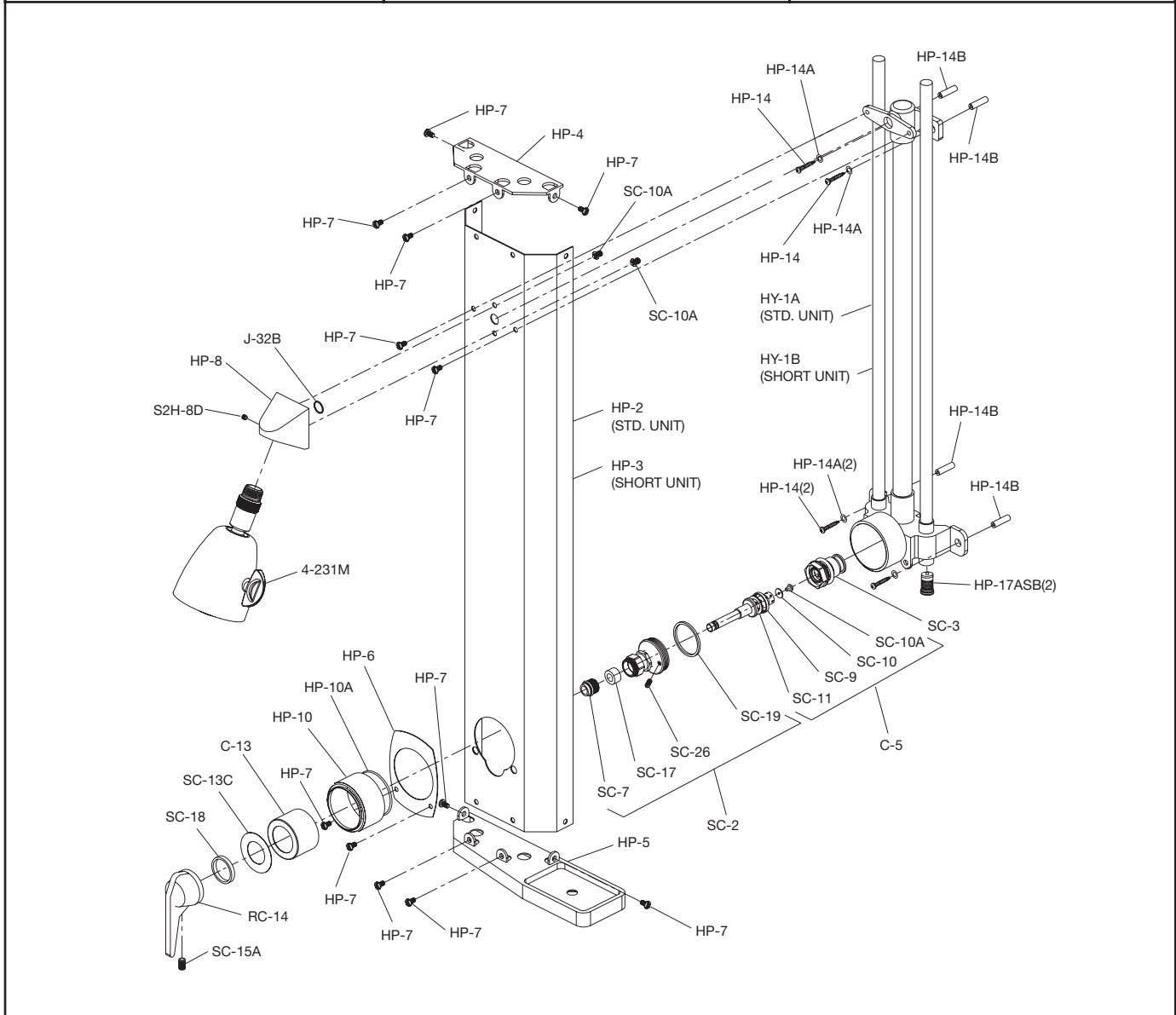

Symmons Industries, Inc. ■ 31 Brooks Drive ■ Braintree, MA 02184
 (800) 796-6667, (781) 848-2250 ■ Fax (800) 961-9621, (781) 843-3849
 Website: www.symmons.com ■ Email: customerservice@symmons.com

© 2008 Symmons Industries, Inc. Printed in U.S.A. ■ ZV-334 (fold) ■ ZV-333 (3h) ■ 050708

