

Installation

Start-Up

Maintenance

Parts

Warranty

TRX150 / TRX199

TRX199C Models

# TRX

Residential Condensing Gas Boiler

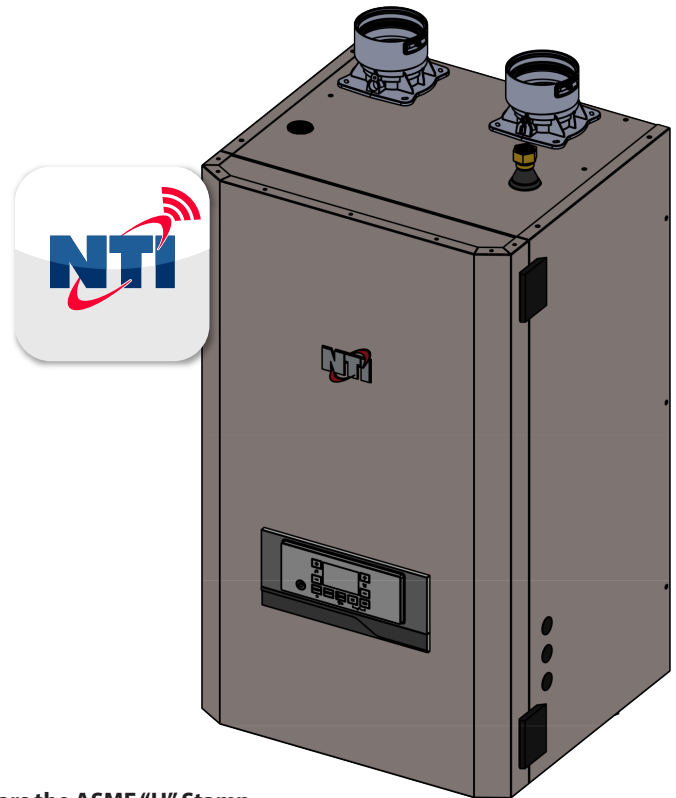

Heat Exchanger Bears the ASME "H" Stamp



86661 Revision Date 8.13.20

## DANGER

THIS MANUAL MUST ONLY BE USED BY A QUALIFIED INSTALLER / SERVICE TECHNICIAN. READ ALL INSTRUCTIONS IN THIS MANUAL BEFORE INSTALLING. PERFORM STEPS IN THE GIVEN ORDER. FAILURE TO DO SO COULD RESULT IN SUBSTANTIAL PROPERTY DAMAGE, SEVERE PERSONAL INJURY, OR DEATH.

## WARNING

Improper installation, adjustment, alteration, service, or maintenance could void product warranty and cause property damage, severe personal injury, or death.

California Proposition 65 Warning: This product contains chemicals known to the State of California to cause cancer, birth defects, or other reproductive harm.

## NOTICE

The manufacturer reserves the right to make product changes or updates without notice and will not be held liable for typographical errors in literature.

The surfaces of these products contacted by potable (consumable) water contain less than 0.25% lead by weight as required by the Safe Drinking Water Act, Section 1417.

## ! WARNING

WARNING: If the information in these instructions is not followed exactly, a fire or explosion may result causing property damage, personal injury or death.

- Do not store or use gasoline or other flammable vapors and liquids in the vicinity of this or any other appliance.

### WHAT TO DO IF YOU SMELL GAS

- Do not try to light any appliance.
- Do not touch any electrical switch; do not use any phone in your building.
- Immediately call your gas supplier from a neighbor's phone. Follow the gas supplier's instructions.
- If you cannot reach your gas supplier, call the fire department.
- Installation and service must be provided by a qualified installer, service agency or the gas supplier.

Improper installation, adjustment, alteration, service, or maintenance can cause injury, property damage, or death. Refer to this manual. Installation and service must be performed by a qualified installer, service agency, or gas supplier.

## FOR YOUR SAFETY READ BEFORE OPERATING

**WARNING: If you do not follow these instructions exactly, a fire or explosion may result, causing property damage, personal injury or loss of life.**

A. This appliance does not have a pilot. It is equipped with an ignition device which automatically lights the burner. Do not try to light the burner by hand.

B. BEFORE OPERATING smell all around the appliance area for gas. Be sure to smell next to the floor because some gas is heavier than air and will settle on the floor.

### WHAT TO DO IF YOU SMELL GAS

- Do not try to light any appliance
- Do not touch any electric switch; do not use any phone in your building
- Immediately call your gas supplier from a neighbor's phone. Follow the gas suppliers' instructions.

- If you cannot reach your gas supplier, call the fire department.

C. Use only your hand to turn the gas control knob. Never use tools. If the handle will not turn by hand, don't try to repair it, call a qualified service technician. Force or attempted repair may result in a fire or explosion.

D. Do not use this appliance if any part has been under water. Immediately call a qualified service technician to inspect the appliance and to replace any part of the control system and any gas control which has been under water.

## OPERATING INSTRUCTIONS

1. STOP! Read the safety information above.
2. Set the thermostat to lowest setting.
3. Turn off all electric power to the appliance.
4. This appliance is equipped with an ignition device which automatically lights the burner. Do not try to light the burner by hand.

GAS VALVE  
ON

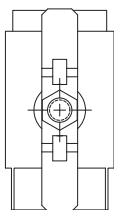

GAS VALVE  
OFF

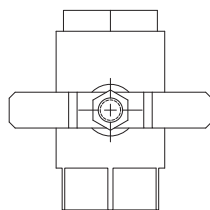

5. Remove front cover.
6. Turn gas shutoff valve to "off". Handle will be across the piping, do not force.
7. Wait five (5) minutes to clear out any gas. If you then smell gas, STOP! Follow "B" in the safety information above on this label. If you don't smell gas, go to next step.
8. Turn gas shutoff valve to "on". Handle will be in line with piping.
9. Install Front Cover.
10. Turn on all electric power to appliance.
11. Set thermostat to desired setting.
12. If the appliance will not operate, follow the instructions "To Turn Off Gas To Appliance" and call your service technician or gas supplier.

## TO TURN OFF GAS TO APPLIANCE

1. Set the thermostat to lowest setting.
2. Turn off all electric power to the appliance if service is to be performed.
3. Remove Front Cover.
4. Turn gas shutoff valve to "off". Handle will be across the piping. Do not force.
5. Install Front Cover.

LP-175 Rev. 4 3-11-08

# SPECIAL ATTENTION BOXES

The following defined terms are used throughout this manual to bring attention to the presence of hazards of various risk levels or to important product information.

## DANGER

DANGER indicates an imminently hazardous situation which, if not avoided, will result in serious personal injury or death.

## WARNING

WARNING indicates a potentially hazardous situation which, if not avoided, could result in personal injury or death.

## CAUTION

CAUTION indicates a potentially hazardous situation which, if not avoided, may result in moderate or minor personal injury.

## CAUTION

CAUTION used without the safety alert symbol indicates a potentially hazardous situation which, if not avoided, may result in property damage.

## NOTICE

NOTICE is used to address practices not related to personal injury.

### Foreword

This manual is intended to be used in conjunction with other literature provided with the boiler. This includes all related control information. It is important that this manual, all other documents included in this system, and additional publications including the *National Fuel Gas Code - ANSI Z223.1* in the United States and the *Natural Gas and Propane Installation Code - B149.1* in Canada (latest versions), be reviewed in their entirety before beginning any work.

Installation should be made in accordance with the regulations of the Authority Having Jurisdiction, local code authorities, and utility companies which pertain to this type of water heating equipment.

Authority Having Jurisdiction (AHJ) – The AHJ may be a federal, state, provincial, local government, or individual such as a fire chief, fire marshal, chief of a fire prevention bureau, labor department or health department, building official or electrical inspector, or others having statutory authority. In some circumstances, the property owner or his/her agent assumes the role, and at government installations, the commanding officer or departmental official may be the AHJ.

**NOTE:** The manufacturer reserves the right to modify product technical specifications and components without prior notice.

### For the Installer

This boiler must be installed by qualified and licensed personnel. The installer should be guided by the instructions furnished with the boiler, and by local codes and utility company requirements. In the absence of local codes, preference should be given to the *National Fuel Gas Code - ANSI Z223.1* in the United States and the *Natural Gas and Propane Installation Code - B149.1* in Canada (latest versions).

#### Installations Must Comply With:

Local, state, provincial, and national codes, laws, regulations, and ordinances.

In the United States - The latest version of the *National Fuel Gas Code, ANSI Z223.1*, from American Gas Association Laboratories, 8501 East Pleasant Valley Road, Cleveland, OH 44131.

The latest version of the *National Electrical Code, NFPA No. 70*.

In Canada - The latest versions of the *Natural Gas and Propane Installation Code, CSA B149.1*, and the *Canadian Electrical Code, C22.1*, from CSA Group, 178 Rexdale Blvd, Toronto, Ontario, Canada M9W 1R3.

**NOTE:** The gas manifold and controls met safe lighting and other performance criteria when undergoing tests specified in *ANSI Z21.13* - latest edition.

 **DANGER**



**FLAMMABLES**



Flammable Vapors

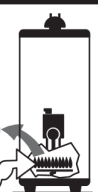

**⚠ Vapors from flammable liquids will explode and catch fire causing death or severe burns.**  
Do not use or store flammable products such as gasoline, solvents or adhesives in the same room or area near the water heater.  
Keep flammable products:  
1. far away from heater,  
2. in approved containers,  
3. tightly closed and  
4. out of children's reach.

Water heater has a main burner and pilot flame.  
The pilot flame:  
1. which can come on at any time and  
2. will ignite flammable vapors.  
Vapors:  
1. cannot be seen,  
2. are heavier than air,  
3. go a long way on the floor and  
4. can be carried from other rooms to the pilot flame by air currents.

**Installation:**  
Do not install water heater where flammable products will be stored or used unless the main burner and pilot flames are at least 18" above the floor. This will reduce, but not eliminate, the risk of vapors being ignited by the main burner or pilot flame.

Read and follow water heater warnings and instructions. If owners manual is missing, contact the retailer or manufacturer.

 **DANGER**

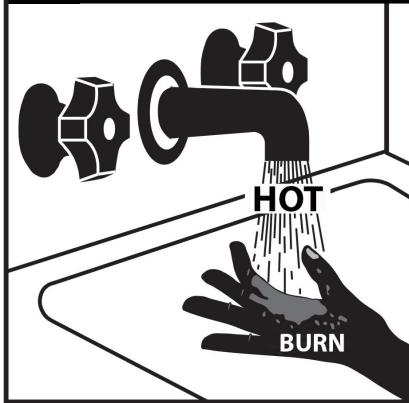

**HOT**  
**BURN**

Water temperature over 125°F can cause severe burns instantly or death from scalds.  
Children, disabled and elderly are at highest risk of being scalded.  
See instruction manual before setting temperature at water heater.  
Feel water before bathing or showering.  
Temperature limiting valves are available, see manual.

## WARNING

**The hydronic supply and return connections of these products are for installation in closed loop systems ONLY!** Use of this product in any manner other than described in this manual may result in premature product failure, substantial property damage, severe personal injury, or death. Damage or failure of this product (or the system in which it is installed) due to unauthorized use **IS NOT COVERED BY WARRANTY.**

## NOTICE

### IMPORTANT

**In accordance with Section 325 (f) (3) of the Energy Policy and Conservation Act, NTI has provided this boiler with multiple features designed to save energy by reducing the boiler water temperature as heating load decreases.**

**These features include:**

- A modulating combustion system that adjusts firing rate based on heat demand.
- Adjustment of boiler set point based on inferred heat load as determined by an outdoor sensor. The outdoor sensor is supplied with this boiler.
- This boiler does not include a standing pilot.
- This boiler is designed and shipped to assure the highest efficiency operation possible. Such high efficiency is achieved by limiting heating circuit water temperature to 140°F when there is no anticipated heat load, based upon the outdoor sensor and the Outdoor Reset Curve (sensor response curve) in the boiler software.
- This feature may be over-ridden as described below in specific installations:
- The boiler control is equipped with an outdoor sensor override for use with building management systems or in cascaded systems (for systems with total input of 300,000 BTU/hr or greater).

See statement below for an important notice on the use of the override.

### IMPORTANT

**In accordance with Section 325 (f) (3) of the Energy Policy and Conservation Act, this boiler is equipped with a feature that saves energy by reducing the boiler water temperature as the heating load decreases. This feature is equipped with an override which is provided primarily to permit the use of an external energy management system that serves the same function. THIS OVERRIDE MUST NOT BE USED UNLESS AT LEAST ONE OF THE FOLLOWING CONDITIONS IS TRUE:**

- An external energy management system is installed that reduces the boiler water temperature as the heating load decreases.
- This boiler is not used for space heating.
- This boiler is part of a modular or multiple boiler system having a total input of 300,000 BTU/hr or greater.

## NOTICE

ASME CSD-1, Section CW-400 requires the temperature controls of hot water heating boilers to

- a) be accepted by a nationally recognized testing agency to conform to UL 353,
- b) shutoff the fuel supply when the system water reaches a preset operating temperature,
- c) have a high temperature limit control that prevents the water temperature from exceeding the maximum allowable temperature by causing safety shutdown and lockout.

The temperature controls of this boiler have been accepted by a nationally recognized testing agency to conform to UL 353; they work to shutoff the fuel supply when the system water temperature reaches the preset operating temperature; and they cause a safety shutdown and lockout, requiring a manual reset to start, when the water temperature reaches 212°F.



## Table of Contents

<b>Part 1 - General Safety Information</b>	<b>6</b>		
A. Operation and Installation Warnings	6		
B. Improper Combustion	7		
C. Gas	7		
D. When Servicing the Boiler	7		
E. Boiler System	7		
F. CH and DHW Loop Water Chemistry Requirements	8		
G. Freeze Protection	8		
H. Water Temperature Adjustment and Scalding	9		
I. High Elevation Installations	9		
<b>Part 2 - Before You Start</b>	<b>10</b>		
A. What's in the Box	10		
B. Optional Equipment	11		
<b>Part 3 - Prepare the Boiler for Installation</b>	<b>12</b>		
A. Locating the Boiler	12		
B. Leveling	13		
C. Clearances for Service Access	13		
D. Wall Mounting Considerations	14		
E. Wall Mounting Instructions	14		
1. Mounting to a Concrete Wall	14		
2. Mounting to a Wood Studded Wall	14		
F. Residential Garage and Closet Installations	15		
G. Exhaust Vent and Intake Pipe	15		
1. Direct Vent of Exhaust and Intake	15		
2. Power Venting, Indoor Combustion Air in Confined or Unconfined Space	15		
H. Carbon Monoxide Detectors	15		
I. Prevent Combustion Air Contamination	16		
J. Removing a Boiler from a Common Vent System	16		
K. Technical Specifications	17		
<b>Part 4 - Water Piping</b>	<b>21</b>		
A. General Plumbing Information	21		
B. Backflow Preventer	21		
C. Expansion Tank	21		
D. Piping the Boiler	21		
E. Internal Circulation Pump	23		
F. CH and DHW Pressure Relief Valves	24		
G. Air Elimination Device	25		
H. Low Water Cut-Off (Field Supplied)	25		
I. Applications*	25		
J. Floor Drying Function	32		
<b>Part 5 - Venting</b>	<b>33</b>		
A. General	33		
B. Approved Materials for Exhaust Vent and Intake Pipe	34		
C. Additional Requirements for Installation in Canada	34		
D. Exhaust Vent and Intake Pipe Location	35		
E. Exhaust Vent and Intake Pipe Sizing	36		
F. Tightening Boiler Collar to Exhaust Vent and Intake Pipe	36		
G. Exhaust Vent and Intake Pipe Installation	36		
H. Applications	39		
1. Direct Vent Installation of Exhaust and Intake	39		
2. Venting Through an Existing System	45		
3. Power Venting, Indoor Combustion Air in Confined or Unconfined Space	46		
<b>Part 6 - Installing the Condensate Drain</b>	<b>47</b>		
<b>Part 7 - Connecting Electrical Service</b>	<b>48</b>		
A. Wiring	48		
1. Connecting Power (120V) for DHW and CH Circulators	48		
2. Low Voltage Wiring Connections	48		
3. Room Thermostat Wiring Connections	49		
4. Outdoor Sensor Connections	49		
5. Aquastat (Default) and Tank Sensor (Optional) Connections (non-Combi Models)	49		
B. Internal Wiring Details	50		
<b>Part 8 - Gas Connections</b>	<b>54</b>		
A. Gas Pipe Sizing Tables	54		
1. Gas Pipe Sizing	54		
		2. Natural Gas Pipe Sizing	54
		3. LP (Liquid Propane) Gas Pipe Sizing	54
		B. Gas Connection Requirements	54
		C. Additional Precaution for Excess Flow Valve (EFV)	55
		D. Checking Gas Pressure at the Boiler for Proper Operation	55
		<b>Part 9 - Controls</b>	<b>56</b>
		A. Control and Display Overview	56
		B. Ignition Procedure	57
		C. Central Heating (CH) Temperature Adjustment	57
		D. Domestic Hot Water (DHW) Temperature Adjustment	57
		E. User Menu	58
		F. INFO Menu	59
		G. Date and Time (If ITIME is set to OFF)	59
		H. Automatic CH Temperature Control (AUTO)	60
		I. Type of Temperature Control	61
		J. Slope of Outdoor Reset Curve	61
		L. Auto Boost	62
		K. Parallel Shift of Reset Curve	62
		M. Room Temperature Day /Night	63
		N. Time Programs – Heating Schedule	63
		O. Automatic Summer / Winter Changeover	63
		P. Technical Menu - Access and Navigation	64
		Q. Technical Menu - Menu Structure	65
		R. Technical Menu - Complete Menu	66
		<b>Part 10 - Start-Up Preparation</b>	<b>74</b>
		A. Check / Control Water Chemistry	74
		B. Check for Gas Leaks	74
		C. Freeze Protection (When Used)	74
		D. System Water Fill, Purge, and Test	75
		E. Purge Air from DHW System	75
		F. Check Thermostat Circuit(s)	75
		G. Condensate Removal	75
		<b>Part 11 - Start-Up</b>	<b>77</b>
		A. First Ignition	77
		B. Combustion Checking Procedure	78
		C. Checking Combustion Parameters	80
		D. Converting the Appliance from Natural Gas to Propane Operation	80
		<b>Part 12 - Installation Checklist</b>	<b>81</b>
		<b>Part 13 - Troubleshooting</b>	<b>83</b>
		A. Boiler Protection Devices	83
		1. Blocking Error	83
		2. Lockout Error	83
		3. Malfunction Warning	83
		B. Boiler Error Codes	84
		<b>Part 14 - Maintenance</b>	<b>88</b>
		A. Procedures	88
		B. Maintenance That May be Performed by the User	88
		C. Maintenance Only to be Performed by a Qualified Service Technician	89
		D. Replacing Components	92
		E. After Maintenance is Complete	94
		<b>Part 15 - Maintenance Report</b>	<b>95</b>
		<b>Part 16 - Shutdown</b>	<b>97</b>
		A. Shutdown Procedure	97
		B. Failure to Operate	97
		C. Important	97
		Maintenance Notes	98
		Customer Installation Record Form	99

## Part 1 - General Safety Information

This boiler is approved for indoor installations only and is not intended for use as a pool heater. Clearance to combustible materials: 0" top, bottom, sides, and back. Boiler must have room for service: 18" front, 14" top, 12" bottom, 2" left and right sides and 0" back are minimum recommended service clearances. (A combustible door or removable panel is acceptable front clearance. A 3" minimum clearance must be provided from the boiler front cover to the removable panel or combustible door.) This boiler has been approved for closet installation and installation on combustible flooring. Do not install directly on carpeting. Install the boiler in a location where relief valve discharge or a leak will not result in damage to the surrounding area. If such a location is not available install an auxiliary catch pan.

This appliance is rated Category IV (pressurized vent, likely to form condensate in the vent) and requires a special vent system designed for pressurized venting. **Use only Category IV vent systems.**

### WARNING

Installer - Read all instructions in this manual before installing. Perform steps in the given order.

User - This manual is for use only by a qualified service technician. Have this boiler serviced / inspected annually by a qualified service technician.

**FAILURE TO ADHERE TO THE GUIDELINES ON THIS PAGE CAN RESULT IN SUBSTANTIAL PROPERTY DAMAGE, SEVERE PERSONAL INJURY, OR DEATH.**

NOTE: Obey all local codes. Obtain all applicable permits before installing the boiler.

NOTE: Install all system components and piping in such a manner that does not reduce the performance of any fire rated assembly.

### A. Operation and Installation Warnings

To avoid serious injury or death, read, understand, and follow all of the precautions listed here.

### DANGER

Vapors from flammable liquids will explode and cause a fire, resulting in personal injury or death. The boiler has a burner that can come on at any time and ignite vapors. **DO NOT** use or store flammable liquids around the boiler.

Improper venting can cause a build-up of carbon monoxide. Breathing carbon monoxide can result in brain damage or death. **DO NOT** operate the boiler unless it is properly vented to the outside and has an adequate fresh air supply for safe operation. Inspect the exterior exhaust gas outlet port and fresh air inlet port on a regular basis to ensure they are functioning properly.

A concentration of carbon monoxide as small as .04% (400 parts per million) in the air can be fatal. When making high fire or low fire adjustments, CO levels must be monitored using a calibrated combustion analyzer such that a CO level of no more than 150 ppm is exceeded at any time during operation.

Adjusting the "low fire offset" or the "main flow restrictor" in small increments can result in a significant increase in CO concentration. To avoid serious injury or death, **DO NOT** make any adjustments to the gas valve without monitoring the exhaust gases with a fully functional and calibrated combustion analyzer.

Failure to follow these instructions will result in property damage, severe personal injury, or death.

### WARNING

This boiler must be installed by a qualified service technician. Improper installation and/or operation can cause a potentially hazardous situation, which if not avoided will void the warranty and could result in serious injury or death.

The manufacturer cannot anticipate every circumstance that might involve a potential hazard. Each installation has its own specialized characteristics, requirements, and possible hazards. Therefore, all possible incidents are not included in these warnings. Proper and safe installation, operation, and service are the responsibility of the qualified service technician.

Proper care of the boiler is the user's responsibility. Ensure the user carefully reads and understands the User's Information Manual before operating the boiler.

Make sure the user knows the location of the gas shut-off valve and how to operate it. Immediately close the gas shut-off valve if the appliance is subjected to fire, overheating, flood, physical damage, or any other damaging condition that might affect the operation of the unit. Have the appliance checked by a qualified service technician before resuming operation.

Do not power up the unit unless the gas and water supply valves are fully opened. Make sure the fresh air intake port and exhaust gas port are open and functional.

No one but a qualified service technician should attempt to install, service, or repair this boiler. There are no serviceable parts which can be changed by the user / owner.

User / Owner: Contact the original qualified service technician if the boiler needs repair / maintenance. If the original technician is unavailable, ask your gas supplier for a list of qualified service providers.

**DO NOT** store or place newspapers, laundry, or other combustible items near the appliance or the exterior exhaust gas outlet and/or fresh air inlet port.

The owner should inspect the system monthly for damage, water stains, signs of rust, corrosion, and exhaust vent and air intake blockage. If inspection of the unit shows signs of damage, the boiler should be shut off until the problem is repaired by a qualified technician.

After installation, all appliance safety devices should be tested.

The boiler is certified for indoor installations only. The boiler consists of gas ignition system components which must be protected from water (dripping, spraying, etc.) during operation and service. Carefully consider installation location and the placement of critical components (circulators, condensate neutralizers, etc.) before installing the boiler.

**DO NOT** allow children to operate this boiler. **DO NOT** use this boiler if it does not appear to be operating correctly. A qualified service technician should service and inspect the boiler annually.

NOTE: If the boiler is exposed to fire or water (or is any way damaged), do not operate. Immediately call a qualified service technician. Failure to follow this information could result in property damage, severe personal injury, or death.

**! WARNING**

DO NOT USE THIS BOILER IF ANY PART HAS BEEN SUBMERGED IN WATER. Immediately call a qualified service technician. The boiler MUST BE replaced if it has been submerged. Attempting to operate a boiler that has been submerged could create numerous harmful conditions, such as a potential gas leakage causing a fire and/or explosion, or the release of mold, bacteria, or other harmful particulates into the air. Operating a previously submerged boiler could result in property damage, severe personal injury, or death. NOTE: Boiler damage due to flood or submersion is considered an Act of God, and IS NOT covered under product warranty.

**! WARNING**

DO NOT alter or modify the appliance or appliance controls. Altering any NTI boiler with parts not manufactured by NTI WILL INSTANTLY VOID the boiler warranty and could result in property damage, personal injury, or death.

**CAUTION**

Due to the low water content of the boiler, improper sizing of the boiler with regard to heating system load will result in excessive cycling and accelerated component failure. DO NOT under or oversize the boiler to the system. Modular boiler installations greatly reduce the likelihood of boiler oversizing. NTI DOES NOT warrant failures caused by improperly sized boiler applications.

High heat sources (sources generating heat 100°F / 37°C or greater, such as stove pipes, space heaters, etc.) may damage plastic components of the boiler as well as plastic vent pipe materials. Such damages ARE NOT covered by warranty. It is recommended to keep a minimum clearance of 8" from high heat sources. Observe heat source manufacturer instructions, as well as local, state, provincial, and national codes, laws, regulations and ordinances when installing this boiler and related components near high heat sources.

Do not use this boiler for anything other than its intended purpose (as described in this manual). Doing so could result in property damage and WILL VOID product warranty.

**NOTICE**

This appliance is equipped with a three prong plug. It should only be plugged directly into a properly grounded three prong receptacle. DO NOT remove the ground plug from the plug.

This appliance provides an overheat shutdown limit. In the event the appliance water temperature exceeds the setpoint of the control limit, the cutoff will trip and the appliance will shut down. Certain local codes require additional temperature limits. In addition, certain types of systems may operate at temperatures below the minimum setpoint of the limit provided with the appliance. Contact the manufacturer for additional overheat controls.

**B. Improper Combustion**

**! WARNING**

Do not obstruct the flow of combustion and ventilating air. Adequate air is necessary for safe operation. Failure to keep the exhaust vent and combustion air intake clear of ice, snow, or other debris could result in property damage, serious personal injury, or death.

**C. Gas**

Should overheating occur or gas supply fail to shut off, turn off the manual gas control valve to the boiler.

**D. When Servicing the Boiler**

**! WARNING**

Be sure to disconnect electrical power before opening boiler cabinet or performing service. Label all wires while performing service to ensure proper re-wiring of the appliance. Wiring errors can cause improper or dangerous operation. Failure to do so could result in electrical shock, improper boiler or system operation, property damage, serious personal injury, or death.

- To avoid electric shock, disconnect electrical supply before performing maintenance.
- To avoid severe burns, allow boiler and associated equipment to cool before servicing.
- Do not use petroleum-based cleaning or sealing compounds in boiler system. Gaskets and seals in the system may be damaged, possibly resulting in substantial property damage.
- Do not use "homemade cures" or "boiler patent medicines". Substantial property damage, damage to the boiler, and/or serious personal injury may result.
- Always verify proper operation after servicing the boiler.

**NOTE:** When inquiring about service or troubleshooting, reference the model and serial numbers from the boiler rating label.

**E. Boiler System**

- Thoroughly flush the system (without the boiler connected) to remove sediment. The high-efficiency heat exchanger can be damaged by build-up or corrosion due to sediment. The manufacturer recommends a suction strainer in this type of system.
- Do not use petroleum-based cleaning or sealing compounds in boiler system. Gaskets and seals in the system may be damaged, possibly resulting in substantial property damage.
- Do not use "homemade cures" or "boiler patent medicines". Substantial property damage, damage to boiler, and/or serious personal injury may result.
- Continual fresh make-up water will reduce boiler life. Mineral buildup in the heat exchanger reduces heat transfer, overheats the stainless steel heat exchanger, and causes failure. Addition of oxygen from make-up water can cause internal corrosion in system components. Leaks in the boiler or piping must be repaired at once.

**NOTE:** DO NOT add cold make up water to the system when the boiler is hot. Thermal shock can potentially cause cracks in the heat exchanger. Such damage IS NOT covered by warranty.

## Part 1 - General Safety Information

### F. CH and DHW Loop Water Chemistry Requirements

#### CAUTION

Chemical imbalance of the water supply may affect efficiency and cause severe damage to the boiler and associated equipment. Water quality must be professionally analyzed to determine whether it is necessary to treat the water. Various solutions are available to adjust water quality. Adverse water quality will affect the reliability of the system. In addition, operating temperatures above 135°F will accelerate the build-up of lime scale and possibly shorten boiler service life. Failure of a boiler due to lime scale build-up, low pH, or other chemical imbalance IS NOT covered by the warranty.

The water must be potable, free of corrosive chemicals, sand, dirt, and other contaminants. It is up to the installer to ensure the water does not contain corrosive chemicals or elements that can damage the heat exchanger. Potable water is defined as drinkable water supplied from utility or well water in compliance with EPA secondary maximum contaminant levels (40 CFR Part 143.3). If the water contains contaminants higher than outlined by the EPA, water treatment is recommended and additional, more frequent maintenance may be required. See Table 1.

If you suspect that your water is contaminated in any way, discontinue use of the appliance and contact an authorized technician or licensed professional.

CH Loop Total Water Hardness Specifications	
Contaminant	Maximum Allowable Level
Total Hardness	120 mg/l (7 grains/gallon)
DHW Loop Total Water Hardness Specifications	
Contaminant	Maximum Allowable Level
Total Hardness (Below 140°F water temperature)	200 mg/l (12 grains/gallon)
Total Hardness (Above 140°F water temperature)	120 mg/l (7 grains/gallon)
CH and DHW Loop Water Quality Specifications	
Contaminant	Maximum Allowable Level
Aluminum	0.05 to 0.2 mg/l or PPM
Chloride	100 mg/l or PPM
Copper	1 mg/l or PPM
Iron	0.3 mg/l or PPM
Manganese	0.05 mg/l or PPM
pH	6.5 - 8.5
Sulfate	205 mg/l or PPM
Total Dissolved Solids (TDS)	500 mg/l or PPM
Zinc	5 mg/l or PPM
Dissolved Carbon Dioxide (CO <sub>2</sub> )	15 mg/l or PPM

Table 1 - Water Quality Specifications

### G. Freeze Protection

#### CAUTION

Consider piping and installation when determining boiler location. Damages resulting from incorrect installation or from use of products not approved by the manufacturer ARE NOT covered by warranty. Failure of the boiler due to freeze related damage IS NOT covered by product warranty.

#### ! WARNING

NEVER use any toxic chemical, including automotive, standard glycol antifreeze, or ethylene glycol made for hydronic (non-potable) systems. These chemicals can attack gaskets and seals in water systems, are poisonous if consumed, and can cause personal injury or death.

#### NOTE: Loops Serving Indirect Water Heaters (IWHs)

Glycol used in IWH loops should be food grade propylene glycol, FDA rated as "generally recognized as safe" (GRAS). If using a glycol / potable water mix, the water chemistry must meet the requirements in this manual. The glycol content of the liquid must not exceed 50%, unless the manufacturer specifies a different ratio. Glycol should be checked periodically to prevent it from becoming acidic. Please refer to guidelines provided by the glycol manufacturer regarding glycol maintenance.

**NOTE:** Glycol not recognized as GRAS may only be used in closed loop CH applications.

**NOTE:** NTI DOES NOT WARRANT THE BOILER AGAINST FREEZE-RELATED DAMAGE.

The boiler control is equipped with freeze protection that activates based on internal water temperature. See the following table for details on freeze protection operation.

**NOTE:** Freeze protection will not be active if the boiler loses power.



FREEZE PROTECTION OPERATION	
STAGE 1	
<b>Condition</b>	The water temperature detected by probes NTC1 or NTC2 ranges between 39°F (4°C) and 46°F (8°C).
<b>Events</b>	<ul style="list-style-type: none"> <li>The internal pump operates at high speed.</li> <li>The 3-Way Valve alternately switches positions - 1 minute on heating mode to 1 minute on DHW mode</li> <li>The display shows the  icon.</li> </ul>
<b>Time</b>	Until the NTC1 and NTC2 temperature is greater than or equal to 46°F (8°C)
If after 20 minutes the conditions described in Stage 1 are still present, the boiler proceeds to Stage 2.	
STAGE 2	
<b>Condition</b>	The water temperature detected by probes NTC1 or NTC2 is less than 39°F (4°C).
<b>Events</b>	<ul style="list-style-type: none"> <li>The burner turns on at minimum power.</li> <li>The 3-Way Valve is positioned on DHW and switches every 30 seconds between CH and DHW.</li> <li>When the temperature is greater than or equal to 104°F (40°C) the burner will turn off. The boiler will maintain the temperature between 95°F (35°C) and 104°F (40°C) for 45 minutes.</li> <li>After 45 minutes there will be 2 minutes of post heating circulation.</li> <li>If the temperature falls below 46°F (8°C) within 150 minutes the burner will immediately power on again.</li> <li>The display shows the  icon.</li> </ul>
<b>Time</b>	Until the NTC1 temperature is greater than or equal to 104°F (40°C)

Table 2 - Freeze Protection Detail



**CAUTION**

On TRX150 / TRX199 Models ONLY  
 If the boiler is to be used only in Heating Mode (not connected to an indirect water heater), the electrical connection of the 3-way valve motor **MUST BE DISCONNECTED** while the boiler is operating in central heating mode. This will lock the valve motor in central heating mode and ensure freeze protection operates properly. Failure to disconnect the valve may disable boiler freeze protection and result in property damage.

**I. High Elevation Installations**

**! WARNING**

Natural gas at high elevation might contain less heating value than the typical 1,000 BTU/cu ft and therefore can cause an improper air / gas mixture leading to improper combustion. For natural gas installations above 3,000 ft, call your gas provider to determine the heating value of the supplied natural gas.

**H. Water Temperature Adjustment and Scalding**

This boiler can deliver scalding water. Be careful whenever using hot water to avoid scalding injury. Certain appliances such as dishwashers and automatic clothes washers may require increased water temperatures. By setting the thermostat on this boiler to obtain the increased water temperature required by these appliances you may create the potential for scald injury.

To protect against injury, install a mixing valve in the water system. This valve will reduce point of use discharge temperatures by mixing cold and hot water in branch supply lines. Such valves are available from your local plumbing supplier.

Table 3 details the relationship of water temperature and time with regard to scald injury and may be used as a guide in determining the safest water temperature for your applications.

**! DANGER**

**HOT**

**BURN**

Water temperature over 125°F can cause severe burns instantly or death from scalds. Children, disabled and elderly are at highest risk of being scalded. See instruction manual before setting temperature at water heater. Feel water before bathing or showering. Temperature limiting valves are available, see manual.

Approximate Time / Temperature Relationships in Scalds	
120°F	More than 5 minutes
125°F	1 1/2 to 2 minutes
130°F	About 30 seconds
135°F	About 10 seconds
140°F	Less than 5 seconds
145°F	Less than 3 seconds
150°F	About 1 1/2 seconds
155°F	About 1 second

**Table 3 - Time and Temperature Relationship in Scalds**

## NOTICE

UNCRATING THE BOILER - Any claims for damage or shortage in shipment must be filed immediately against the transportation company by the consignee.

Remove the boiler and accessory box from the packaging. Take care to place the boiler and accessories in a safe location prior to installation to prevent damage to the mechanical connections.

### A. What's in the Box

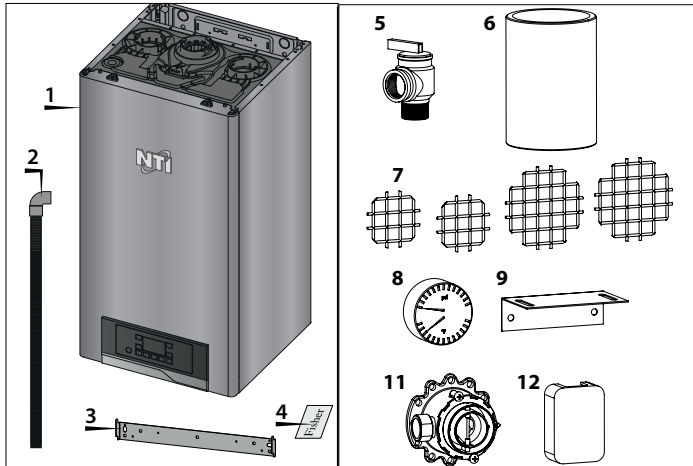

Included components:

Nr.	Quantity	Description
1	1	Condensing Gas Boiler
2	1	Condensate Drain Pipe
3	1	Upper Bracket
4	2	Assembly Screws (Fischer Type SX)
5	1	CH Pressure Relief Valve
6	1	3" CPVC Pipe, 5" Long
7	2 + 2	2" Vent Screen + 3" Vent Screen (3" Only - 199 Models)
8	1	Tridicator
9	1	Lower Bracket
10	1	Installation Manual (This Document)
	1	User's Information Manual
	1	Connectivity Quick Start Guide
	1	LP Conversion Instructions
	1	Warranty
	1	Programming Guide
11	1	LP Gas Conversion Kit
12	1	Outdoor sensor Kit
13	1	3/4" Cap (Not Included with Combis, and not shown)

Table 4 - Included with the Boiler

### How the Boiler Operates

TRX condensing technology intelligently delivers hydronic heating while maximizing efficiency. Outlined below are system features and operation:

#### Stainless Steel Heat Exchanger

The highly efficient stainless steel heat exchanger is designed to extract all available heat from the supply line before it is exhausted.

#### Modulating Combustion System

The combustion system modulates the output of the burner during operation to match system demand and achieve the control set point while in operation. The set point can change by internal or external signals to enhance the overall performance of the system.

#### Control

The integrated control system monitors the system and regulates fan speed to control boiler output. This allows the boiler to deliver only the amount of heat energy required and nothing more.

The control can be set to monitor outdoor temperature through an outdoor sensor or through internet weather (with optional WiFi connection), use an optional room sensor, or use both outdoor temperature and an optional room sensor to regulate boiler set point. The system can be further enhanced by installing an indirect water heater to provide domestic hot water.

The control can regulate the output of multiple boilers through its cascade system function. The cascade system is capable of connecting up to eight boilers together in such a way that they function as one boiler system. This allows for greater turn down ratios and provides systematic control of the multiple boilers in an installation to minimize downtime and maximize efficiency.

The cascade system works by establishing one boiler as the master and the other connected boilers as followers. The master boiler requires a sensor to provide feedback on set point temperature in order to adjust heating input from the connected boilers. Each cascaded boiler will have its own pump to provide maximum flow and control heat exchanger flow rate.

#### Text Display and Operational Display Icons

The display allows the user to change system parameters and monitor system outputs.

#### Gas Valve

Senses suction from the blower, allowing gas to flow only if powered and combustion air is flowing.

#### Integrated Venturi

Controls air and gas flow into the burner.

#### Burner

The high grade stainless steel burner uses premixed air and gas to provide a wide range of firing rates.

#### Spark Ignition

The burner is ignited by applying high voltage through the system spark electrode. The spark from the electrode ignites mixed gas off of the burner.

#### Supply Water Temperature Sensor

This sensor monitors the boiler outlet water temperature (System Supply). The control adjusts boiler firing rate so the supply temperature will match the boiler set point.

#### Return Water Temperature Sensor

This sensor monitors boiler return water temperature (System Return).

#### Flue Sensor

Monitors flue temperature and adjusts firing rate.

#### Temperature and Pressure Gauge

Allows the user to monitor system temperature and pressure.

#### Electrical field connections with terminal strips

The electrical cover allows easy access to the clearly marked line voltage and low voltage terminal strips to facilitate wiring the boiler.

#### Condensate Collection System

This boiler is a high efficiency appliance and will produce condensate. The condensate collection system has a float switch which monitors condensate level and prevents condensate from backing up into



the combustion system. Inside the collection system is a built in trap which seals the combustion system from the connected drain. This condensate should be neutralized to avoid damage to the drainage system or piping.

**Outdoor Sensor**

Monitors outdoor temperature and adjusts unit set point to provide greater efficiency.

**0-10 Volt Input / 4-20 mA Input (with Optional Analog Clip-In Board, part # 3319457)**

Allows the installer to connect a BMS (Building Management System) to control the boiler.

**Condensate Trap**

The condensate trap prevents condensate and heat exchanger exhaust from backing up into the boiler.

**Pump Service Mode**

Allows manual operation of pumps to commission system and check pump operation.

**Internal By-Pass Valve**

Protects the boiler from damage in low flow conditions.

**Internal ECM Pump**

The internal ECM Pump uses less electricity than standard pumps, providing high performance operation.

**DHW Temperature Sensor**

Monitors DHW outlet temperature. The control adjusts boiler firing rate to match the DHW supply temperature to the set point.

**DHW Flow Meter**

Monitors DHW flow rate.

**B. Optional Equipment**

Optional equipment available from NTI (and Part #):

- System Sensor (84010)
- 3" PVC Concentric Vent Kit (84634)
- 3" PVC Low Profile Vent Kit (84357)
- 2" PVC Low Profile Vent Kit (85062)
- Tank Sensor (84632)

**NOTE:** When using an optional system sensor, pipe insulation must be wrapped around it to improve temperature measurement accuracy and increase overall system efficiency.

## Part 3 - Prepare the Boiler for Installation

### CAUTION

**COLD WEATHER HANDLING** - If the boiler has been stored in a very cold location (BELOW 0°F) before installation, handle with care until the components come to room temperature. Failure to do so could result in damage to the boiler.

Carefully consider installation when determining boiler location. Please read the entire manual before attempting installation. Failure to properly take factors such as boiler venting, piping, condensate removal, and wiring into account before installation could result in wasted time, money, and possible property damage and personal injury.

### A. Locating the Boiler

### ! WARNING

This boiler is certified for indoor use only. **DO NOT INSTALL OUTDOORS.** Outdoor installations **ARE NOT** covered by warranty. Failure to install the boiler indoors could result in property damage, severe personal injury, or death.

Incorrect ambient conditions can lead to damage to the heating system and put safe operation at risk. Ensure that the installation location adheres to the information included in this manual. Failure to do so could result in property damage, serious personal injury, or death. Failure of boiler or components due to incorrect operating conditions **IS NOT** covered by product warranty.

This boiler must be installed upright in the vertical position as described in this manual. **DO NOT** attempt to install this boiler in any other orientation. Doing so will result in improper boiler operation and property damage, and could result in serious personal injury or death.

#### 1. Installation Area (Mechanical Room) Operating Conditions

- Ensure ambient temperatures are higher than 32°F / 0°C and lower than 104°F / 40°C
- Prevent the air from becoming contaminated by the products, places, and conditions listed in this manual
- Avoid continuously high levels of humidity
- Never close existing ventilation openings
- Ensure a minimum 1" clearance around hot water and exhaust vent pipes
- **NOTE:** To prevent condensing in the fan, it is recommended to avoid prolonged exposure to temperatures below 45°F

### ! WARNING

This boiler has a condensate disposal system that may freeze if exposed to sustained temperatures below 32°F. Precautions should be taken to protect the condensate trap and drain lines from sustained freezing conditions.

Circulators suitable for DHW applications must be used.

Failure to take precautions could result in property damage, severe personal injury, or death.

### CAUTION

The service life of the boiler's exposed metallic surfaces, such as the casing, as well as internal surfaces, such as the heat exchanger, are directly influenced by proximity to damp and salty marine environments. In such areas higher concentration levels of chlorides from sea spray coupled with relative humidity can lead to degradation of boiler components. In these environments, boilers must not be installed using direct vent systems which draw outdoor air for combustion. Such boilers must be installed using room air for combustion. Indoor air will have a much lower relative humidity, and hence potential corrosion will be minimized.

Failure of the boiler or components due to incorrect operating conditions **IS NOT** covered by product warranty.

#### 2. Check for nearby connections to:

- System water piping
- Venting connections
- Gas supply piping
- Electrical power
- Condensate drain

#### 3. Check area around boiler. Remove any combustible materials, gasoline, and other flammable liquids.

### ! WARNING

Failure to keep the boiler area clear and free of combustible materials, liquids, and vapors can result in substantial property damage, severe personal injury, or death.

#### 4. Gas control system components must be protected from dripping water during operation and service.

#### 5. If the boiler is to replace an existing boiler, check for and correct any existing system problems, such as:

- System leaks
- Location that could cause the system and boiler to freeze and leak
- Incorrectly sized expansion tank

### CAUTION

Always take future maintenance into consideration when locating the boiler. If the boiler is located in an installation location with limited clearances, it may be necessary to remove the boiler from the space to perform maintenance. Failure to consider maintenance when determining installation location could result in property damage.

#### 6. Clean and flush system when reinstalling a boiler.

### ! WARNING

Do not introduce toxic chemicals, such as antifreeze or appliance treatments, into any piping meant for potable water purposes.

Do not connect DHW connections to any heating systems or components that have been previously used for nonpotable applications.

Ensure that all piping and components connected to the appliance are suitable for potable water applications.

Failure to follow these instructions could result in serious personal injury or death.

## Part 3 - Prepare the Boiler for Installation

**NOTE:** When installing in a zero clearance location, it may not be possible to read or view some product labeling. It is recommended to make note of the boiler model and serial number.

**NOTE:** A combustible door or removable panel is acceptable front clearance.

### B. Leveling

#### CAUTION

The boiler must be installed level for the condensate to properly flow out of the collection system. Failure to do so will result in improper appliance operation.

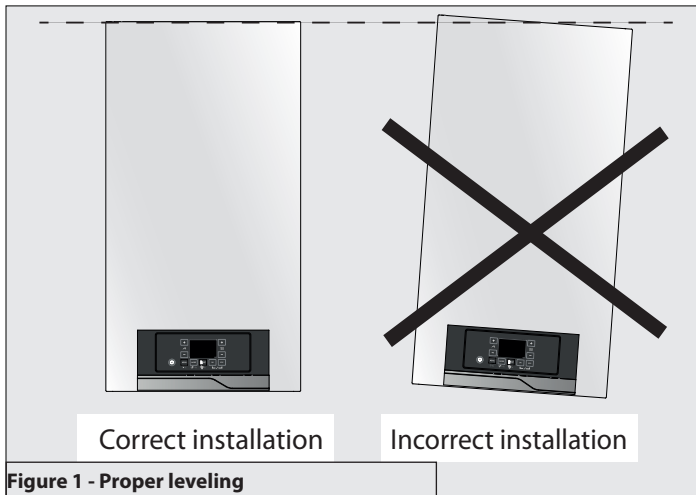

### C. Clearances for Service Access

**NOTE:** If you do not provide the minimum clearances shown in Figure 2 and Table 5 it might not be possible to service the boiler without removing it from the space.

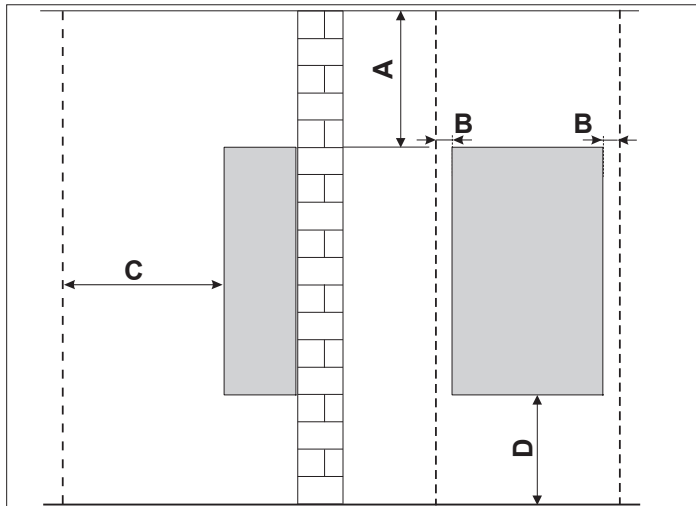

Figure 2 - Minimum Clearances

Dimension	Description	Clearance
A	Top	14" (355.6 mm)
B	Right or Left Side	2" (50.8 mm)
C	Front	18" (457.2 mm)
D	Bottom	12" (304.8 mm)
Not Displayed	Back	0" (0 mm)

Table 5 - Minimum Installation and Service Clearances

**NOTE:** For closet installations, a combustible door or removable panel is acceptable front clearance. A 3" minimum clearance must be provided from the appliance front cover to the removable panel or combustible door.

#### Minimum Clearances from Combustible Materials

- Hot water pipes - at least 1" from combustible materials
- Exhaust vent pipe - at least 1" from combustible materials

#### CAUTION

All boilers eventually leak. Locate the boiler where any leakage from the relief valve, related piping, tank, or connections will not result in damage to surrounding areas or lower floors of the building. Any boiler should be installed in such a manner that if it should leak the resulting flow of water will not cause damage to the area in which it is installed. If the boiler is installed in a location where a leak could cause damage, it is required to provide containment measures. Such measures include but are not limited to: a properly sized drain pan installed beneath the boiler and piped to an open drain line, or installing the boiler on a concrete floor pitched to a free flowing drain. Failure to provide containment measures is the sole responsibility of the owner and/or installer. Leakage damages ARE NOT covered by warranty.

In addition, water leak detection devices and automatic water shutoff valves are readily available at plumbing supply houses. IT IS HIGHLY RECOMMENDED BY THE MANUFACTURER TO INSTALL WATER LEAK DETECTION DEVICES AND AUTOMATIC SHUTOFF VALVES IN ANY BOILER INSTALLATION WHERE A LEAKAGE OF WATER COULD RESULT IN PROPERTY DAMAGES.

#### Boiler Area Ventilation Air Openings - Closet Installations

If the boiler is installed in a closet or alcove the boiler area/room must be ventilated.

**EXCEPTION:** If the boiler area/room has a volume of 150 ft<sup>3</sup> or greater, ventilation of the boiler area/room is not required.

Each ventilation air opening must meet the minimum requirements of 1 in<sup>2</sup> per 1000 BTU/hr., but not less than 100 in<sup>2</sup>. The lower ventilation opening must be located within 6 in. of the floor, while the upper opening must be located 6 in. from the top of the space.

#### ! WARNING

If the boiler area has a volume less than 150 ft<sup>3</sup>, it is considered a Closet or Alcove. In the US/Canada, PVC vent pipe and fittings SHALL NOT BE USED within the closet or alcove. Only approved CPVC, Polypropylene, or Stainless Steel vent pipe and fittings may be used. See Table 11 for a list of approved materials. Under all circumstances proper ventilation must be provided.

The space must be provided with correctly sized combustion/ventilation air openings for all other appliances located in the space with the boiler. For power venting installations using room air for combustion, refer to the boiler venting section, this manual, for descriptions of confined and unconfined spaces. Do not install the boiler in an attic. The boiler cover must be securely fastened to prevent the boiler from drawing air from the boiler room. This is particularly important if the boiler is in a room with other appliances. Failure to comply with the above warnings could result in substantial property damage, severe personal injury, or death.

#### Alcove Installations

Alcove installations have the same minimum dimensions as closet installations, except the installation must be completely open to the room at a distance no greater than 18 in. (457 mm) from the front of the boiler and the room must be at least three (3) times the size of the alcove. Provided these conditions are met, the boiler requires no extra ventilation air openings to the space. If these conditions are not met, follow the requirements for Closet Installations.

## Part 3 - Prepare the Boiler for Installation

### D. Wall Mounting Considerations

These boilers are wall mounted. Use only the wall mounting instructions included with this boiler.

Ensure the wall that the boiler is intended to be mounted on is comprised of cement, brick, block, or wooden studs spaced 16" apart from center. Ensure the wall is capable of supporting at least 150 lbs (68 kgs).

If flooding is possible, elevate the boiler to prevent floodwater from reaching the boiler.

Ensure the boiler is installed in a location that minimizes the risk of water damage due to leaking valves, pumps, unions, etc.

The boiler may be installed on any suitable internal wall (suitable sound-proofing may be required when installing onto a stud partition wall).

#### ! WARNING

Ensure that the structure of the installation location is sufficient to support the full installed weight of the boiler, including water content of the heat exchanger and related piping and components. If the mounting location cannot support a minimum of 150 lbs. (68 kg), it is recommended to locate the boiler in a mounting location that can support the minimum weight. Failure to ensure the structure of the installation location is structurally sound before installation of the boiler and properly mount the boiler can result in structural failure, substantial property damage, severe personal injury, or death.

Do not mount the boiler to a hollow wall.

### E. Wall Mounting Instructions

#### ! WARNING

This boiler is too heavy for one person to lift. It is highly recommended to install the boiler with two people. Use caution as to not drop the boiler, which could damage the boiler and cause property damage and/or severe personal injury. Verify that the boiler is properly and securely mounted before leaving unsupervised. Failure to comply with the above and properly mount the boiler could result in substantial property damage, severe personal injury, or death.

#### 1. Mounting to a Concrete Wall

1. Position the upper wall mounting bracket on the concrete wall. Ensure the bracket is level. Then use the bracket as a template to mark four (4) drilling holes on the wall - two (2) on each side of the bracket. See Figure 3 for details.

2. Drill and plug the wall. Then secure the upper mounting bracket using the provided Fischer S 10x50 screws. Ensure the bracket is level.

3. Install the lower mounting bracket on the boiler. Then hang the boiler on the upper mounting bracket. Ensure the boiler is level. Then use the lower bracket to mark the lower bracket drilling holes.

4. Drill and plug the wall and secure the lower mounting bracket using field provided screws. Then adjust the lower mounting bracket on the boiler. Ensure the boiler is installed plumb. Tighten the bracket to the boiler.

#### ! WARNING

This wall mounting system is not seismic rated and should not be applied as such. Failure to comply with the above and properly mount the boiler could result in substantial property damage, severe personal injury, or death.

Use extreme care not to drop the boiler or cause bodily injury while lifting or mounting the boiler onto the wall mount bracket.

Failure to follow these instructions could result in property damage, severe personal injury, or death.

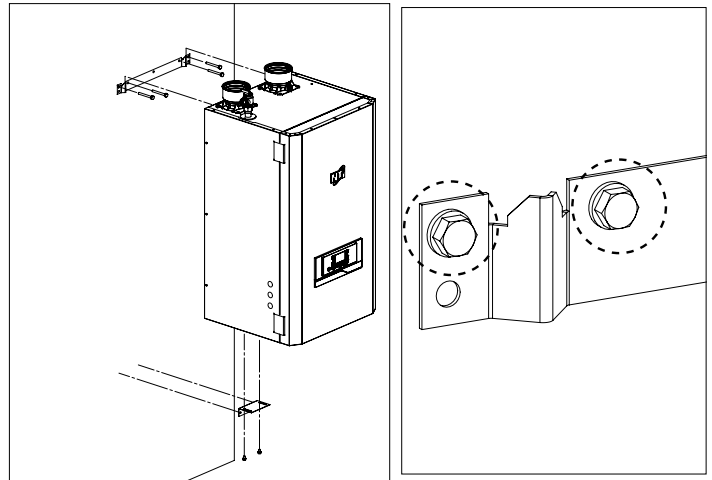

Figure 3 - Mounting to a Concrete Wall

#### ! WARNING

The manufacturer cannot anticipate all installation conditions. These instructions and included parts may not apply to wall-mounting the appliance at your installation location. The appliance must be properly and securely mounted by a qualified installer according to installation conditions, the technical specifications of the appliance, and to meet AHJ / building code requirements. All applicable permits must be obtained before installing the appliance. Failure to follow these instructions could result in property damage, severe personal injury, or death. Any damages resulting from improper installation are not covered by product warranty.

#### 2. Mounting to a Wood Studded Wall

#### CAUTION

If the boiler is not installed upright, vertically plumb, and level, improper and unsatisfactory operation may occur, causing excessive condensation build-up, nuisance fault codes, and unnecessary maintenance.

1. Position the upper wall mounting bracket on the wall. Ensure the bracket is level and the drilling holes are on stud. Then use the bracket as a template to mark four (4) drilling holes on the wall - two (2) on each side of the bracket. See Figure 4 for details.

2. Drill and plug the wall. Then secure the upper mounting bracket using the provided Fischer S 10x50 screws and field provided washers for wood mounting.

3. Install the lower mounting bracket on the boiler. Then hang the boiler on the upper mounting bracket. Ensure the boiler is level. Then use the lower bracket to mark the lower bracket drilling holes.

4. Drill and plug the wall and secure the lower mounting bracket using field provided screws. Then adjust the lower mounting bracket on the boiler. Ensure the boiler is installed plumb. Tighten the bracket to the boiler.

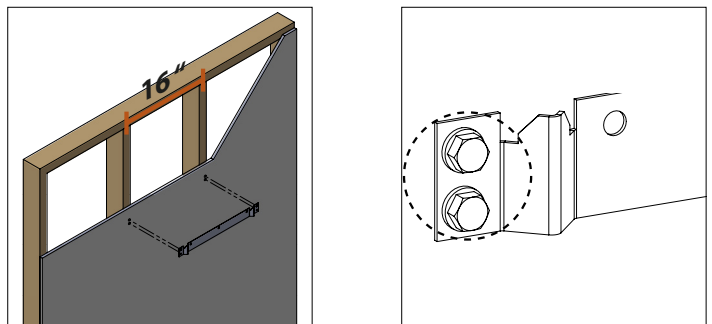

Figure 4 - Mounting the Bracket on 16" Center Studs

### F. Residential Garage and Closet Installations

#### CAUTION

Check with your local Authority Having Jurisdiction for requirements when installing boiler in a garage or closet. Please read the entire manual before attempting installation. Failure to properly take factors such as boiler venting, piping, condensate removal, and wiring into account before installation could result in wasted time, money, and possible property damage and personal injury.

#### Precautions

If the boiler is located in a residential garage, per ANSI Z223.1:

- Mount the bottom of the boiler a minimum of 18" above the floor of the garage to ensure the burner and ignition devices are well off the floor.
- Locate or protect the boiler so it cannot be damaged by a moving vehicle.

#### ! WARNING

The space must be provided with correctly sized combustion/ventilation air openings for all other appliances located in the space with the boiler. For power venting installations using room air for combustion, refer to the boiler venting section, this manual, for descriptions of confined and unconfined spaces. Do not install the boiler in an attic. Failure to comply with these warnings could result in substantial property damage, severe personal injury, or death.

### G. Exhaust Vent and Intake Pipe

The boiler is rated ANSI Z21.13 Category IV (pressurized vent, likely to form condensate in the vent) and requires a special vent system designed for pressurized venting.

**NOTE: The venting options described here (and further detailed in the Venting section, this manual) are the lone venting options approved for this boiler. Failure to vent the boiler in accordance with the provided venting instructions will void the warranty.**

#### ! DANGER

Failure to vent the boiler properly will result in serious personal injury or death.

#### ! WARNING

Do not attempt to vent this boiler by any means other than those described in this manual. Doing so will void the warranty and may result in severe personal injury or death.

Vents must be properly supported. Boiler exhaust and intake connections are not designed to carry heavy weight. Vent support brackets must be within 1' of the boiler and the balance at 4' intervals. Boiler must be readily accessible for visual inspection for first 3' from the boiler. Failure to properly support vents could result in property damage, severe personal injury, or death.

The exhaust discharged by this boiler may be very hot. Avoid touching or other direct contact with the exhaust gases of the vent termination assembly. Doing so could result in severe personal injury or death.

#### 1. Direct Vent of Exhaust and Intake

If installing a direct vent option, combustion air must be drawn from the outdoors directly into the boiler intake and exhaust must terminate outdoors. There are three basic direct vent options detailed in this manual: 1. Side Wall Venting, 2. Roof Venting, and 3. Unbalanced Venting.

Be sure to locate the boiler such that the exhaust vent and intake piping can be routed through the building and properly terminated. Different vent terminals can be used to simplify and eliminate multiple penetrations in the building structure (see Optional Equipment in Venting Section). The exhaust vent and intake piping lengths, routing, and termination methods must all comply with the methods and limits given in the Venting Section, this manual.

When installing a combustion air intake from outdoors, care must be taken to utilize uncontaminated combustion air. **To prevent combustion air contamination, see Table 6.**

#### 2. Power Venting, Indoor Combustion Air in Confined or Unconfined Space

This boiler requires fresh, uncontaminated air for safe operation and must be installed in a mechanical room where there is adequate combustion and ventilating air. **NOTE: To prevent combustion air contamination, see Table 6.**

Combustion air from the indoor space can be used if the space has adequate area or when air is provided through a duct or louver to supply sufficient combustion air based on the boiler input. Never obstruct the supply of combustion air to the boiler. If the boiler is installed in areas where indoor air is contaminated (see Table 6) it is imperative that the boiler be installed as direct vent so that all combustion air is taken directly from the outdoors into the boiler intake connection.

**Unconfined space** is space with volume greater than 50 cubic feet per 1,000 BTU/hr (4.8 cubic meters per kW) of the total input rating of all fuel-burning appliances installed in that space. Rooms connected directly to this space through openings not furnished with doors are considered part of the space. See Venting Section for details.

**Confined space** is space with volume less than 50 cubic feet per 1,000 BTU/hr (4.8 cubic meters per kW) of the total input rating of all fuel-burning appliances installed in that space. Rooms connected directly to this space through openings not furnished with doors are considered part of the space.

When drawing combustion air from inside a conventionally constructed building to a confined space, such space should be provided with two permanent openings: one located 6" (15 cm) below the space ceiling, the other 6" (15cm) above the space floor. Each opening should have a free area of one square inch per 1,000 BTU/hr (22cm<sup>2</sup>/kW) of the total input of all appliances in the space, but not less than 100 square inches (645cm<sup>2</sup>). If the confined space is within a building of tight construction, air for combustion must be obtained from the outdoors as outlined in the Venting section of this manual.

#### CAUTION

When drawing combustion air from the outside into the mechanical room, care must be taken to provide adequate freeze protection.

#### ! WARNING

Failure to provide an adequate supply of fresh combustion air can cause poisonous flue gases to enter the living space, resulting in severe personal injury or death. To prevent combustion air contamination, see Table 6.

### H. Carbon Monoxide Detectors

#### In the Commonwealth of Massachusetts and As Required by State and Local Codes:

Installation of Carbon Monoxide Detectors: At the time of installation or replacement of the vented gas fueled appliance, the installing plumber or gas fitter shall observe that a hard wired carbon monoxide detector with an alarm and battery back-up is installed on the floor level where the gas appliance is installed, unless the appliance is located in a detached, uninhabitable structure separate from the dwelling, building, or structure used in whole or in part for residential purposes.

In addition, the installing plumber or gas fitter shall observe that a hard wired carbon monoxide detector with an alarm and battery back-up is installed on each additional level of the dwelling, building, or structure served by the vented gas appliance. It shall be the responsibility of the



## Part 3 - Prepare the Boiler for Installation

property owner to secure the service of qualified licensed professionals for the installation of hard wired carbon monoxide detectors.

a. In the event that the vented gas fueled appliance is installed in a crawl space or attic, the hard wired carbon monoxide detector with alarm and battery back-up shall be installed on the next adjacent floor level.

b. In the event that these requirements cannot be met at the time of completion of installation, the owner shall have a period of thirty (30) days to comply with the above requirements; provided, however, that during said thirty (30) day period, a battery operated carbon monoxide detector with an alarm shall be installed.

### **! WARNING**

Do not attempt to vent this appliance by any means other than those described in this manual. Doing so will void the warranty and may result in severe personal injury or death.

Approved Carbon Monoxide Detectors: Each carbon monoxide detector as required in accordance with the above provisions shall comply with NFPA 70 and be ANSI/UL 2034 listed and IAS certified.

### I. Prevent Combustion Air Contamination

Install intake air piping for the boiler as described in the Venting Section, this manual. Do not terminate exhaust in locations that can allow contamination of intake air.

### **! WARNING**

Ensure that the intake air will not contain any of the contaminants in Table 6. Contaminated air will damage the boiler, resulting in possible substantial property damage, severe personal injury, or death. For example, do not pipe intake air near a swimming pool or laundry facilities. These areas always contain contaminants.

Products to Avoid	Areas Likely to Have Contaminants
Spray cans containing fluorocarbons	Dry cleaning / laundry areas and establishments
Permanent wave solutions	Swimming pools
Chlorinated waxes / cleaners	Metal fabrication plants
Chlorine-based swimming pool chemicals	Beauty shops
Calcium chloride used for thawing	Refrigeration repair shops
Sodium chloride used for water softening	Photo processing plants
Refrigerant leaks	Auto body shops
Paint or varnish removers	Plastic manufacturing plants
Hydrochloric or Muriatic acid	Furniture refinishing areas and establishments
Cements and glues	New building construction
Antistatic fabric softeners used in clothes dryers	Remodeling areas
Chlorine-type bleaches, laundry detergents, and cleaning solvents	Garages and workshops
Adhesives used to fasten building products	

**Table 6 - Products and Areas Likely to Have Contaminants**

**NOTE: DAMAGE TO THE BOILER CAUSED BY EXPOSURE TO CORROSIVE VAPORS IS NOT COVERED BY WARRANTY.** (Refer to the limited warranty for complete terms and conditions.)

### J. Removing a Boiler from a Common Vent System

#### **! DANGER**

Do not install the boiler into a common vent with any other appliance. This will cause flue gas spillage or appliance malfunction, resulting in possible substantial property damage, severe personal injury, or death.

#### **! WARNING**

Failure to follow all instructions can result in flue gas spillage and carbon monoxide emissions, causing severe personal injury or death.

When removing an existing boiler, follow the steps below.

1. Seal any unused openings in the common venting system.
2. Visually inspect the venting system for proper size and horizontal pitch to determine if there is blockage, leakage, corrosion, or other deficiencies that could cause an unsafe condition.
3. If practical, close all building doors, windows, and doors between the space in which the boiler remains connected to the common venting system and other spaces in the building. Turn on clothes dryers and any appliances not connected to the common venting system. Turn on any exhaust fans, such as range hoods and bathroom exhausts, at maximum speed. Do not operate a summer exhaust fan. Close all fireplace dampers.
4. Place in operation the appliance being inspected. Follow the lighting instructions. Adjust the thermostat so the appliance will operate continuously.
5. Test for spillage at the draft hood relief opening after 5 minutes of main burner operation. Use the flame of a match or candle or smoke from a cigarette.
6. After it has been determined that each appliance remaining connected to the common venting system properly vents when tested as outlined, return doors, windows, exhaust fans, fireplace dampers, and any other gas burning appliances to their previous condition of use.
7. Any improper operation of the common venting system should be corrected to conform to the National Fuel Gas Code, ANSI Z223.1. When resizing any portion of the common venting system, the system should approach the minimum size as determined using the appropriate tables in Appendix G of ANSI Z223.1.

**! WARNING**

Breathing Hazard - Carbon Monoxide Gas



- Do not operate heater if flood damaged.
- Install vent system in accordance with local codes and manufacturers installation instructions.
- Do not obstruct heater air intake or exhaust. Support all vent piping per manufacturers installation instructions.
- Do not place chemical vapor emitting products near unit.
- According to NFPA 720, carbon monoxide detectors should be installed outside each sleeping area.
- Never operate the heater unless it is vented to the outdoors.
- Analyze the entire vent system to make sure that condensate will not become trapped in a section of vent pipe and therefore reduce the open cross sectional area of the vent.

Breathing carbon monoxide can cause brain damage or death. Always read and understand instruction manual.

LP-304

**Figure 5 - CO Warning Label**



**K. Technical Specifications**

Model		TRX150	TRX199	TRX199C		
Type		Boiler		Combi		
Installation		Indoor, Wall Hung, Fully Condensing				
Minimum / Maximum Input (Btu/Hr) <sup>1</sup>		15,000 / 150,000	NG	19,700 / 197,000	NG	19,700 / 197,000
			LP	19,200 / 192,000	LP	19,200 / 192,000
DOE AFUE <sup>2</sup> (%)		95	95	95		
Heating Capacity <sup>1,2</sup> (MBH)		139	184	184		
Net AHRI Rating, Water (MBH) <sup>2</sup>		121	160	160		
Hot Water Capacity	35°F Rise	N/A	N/A	10.5		
	45°F Rise	N/A	N/A	8.2		
	77°F Rise	N/A	N/A	4.8		
Flue System		Category IV, Sealed Combustion Direct Vent, Power Vent				
Minimum - Maximum Exhaust Vent Run <sup>3</sup>		2" (6 - 100 feet) / 3" (6 - 150 feet)	3" (6 - 150 feet)			
Minimum - Maximum Intake Air Pipe Run <sup>3</sup>		2" (0 - 100 feet) / 3" (0 - 150 feet)	3" (0 - 150 feet)			
Approved Exhaust Vent Materials <sup>3</sup>		PVC, CPVC, PP, Stainless Steel				
Shipping Weight (lbs)		115	125	130		
Gas Supply Pressure	NG	3.5" to 10.5" WC				
	LP	8" to 13" WC				
Power Supply		120V, 60 Hz, less than 12A				
General Operating Conditions		Ambient Temperature Range: 33 – 104°F (0.6 – 40°C) Product Approvals and Requirements: ANSI Z21.13 / CSA 4.9				
Ignition System		Direct Electronic Spark Ignition / Flame Rectification				
Burner System		Premixed Fuel Modulation / Stainless Steel Burner				
Gas Valve System		Air Ratio Valve				
Dimensions (in Inches)	W	19.75"				
	H	38.25"				
	D	18.5"				
Approx. Full Boiler Weight (lbs)		115	130	135		
Boiler Water Content (Gallons)		2	2.7			
Boiler Setpoint Temperature Range		68 – 122°F Low Temperature / 86 - 179°F High Temperature				
DHW Indirect Setpoint Temperature Range		104 – 149°F				
DHW Setpoint Range (Combi Models)		97 – 140°F				
Water Pressure (PSI)	Heat Exchanger MAWP	50				
	Pressure Relief Valve	30				
	DHW Max Pressure	N/A	N/A	150		
Control Panel / Main Controller		AristonThermo LCD Display / AristonThermo GALEVO2 Control				
Connection Sizes	CH Supply / Return	1 1/4" Male NPT				
	DHW Inlet / Outlet	3/4" Male NPT				
	Gas Inlet	3/4" Male NPT				
Materials	Cabinet	Painted and Galvanized Steel				
	Heat Exchanger	Type 441 Stainless Steel Water Tube				
Safety Devices		Flame Rectifier Probe, Temperature Limit Control (190°F), Water Pressure Switch (Min. 8 PSI), Freeze Protection, Condensate Trap, Flue Temperature High Limit Sensor (210°F)				

**Table 7 - Technical Specifications**

**NOTES:**

<sup>1</sup> Listed Input and Output Ratings are at minimum vent lengths at an altitude of 0 - 2000 ft. Numbers will be lower with longer venting and/or altitudes greater than 2000 ft.

<sup>2</sup> Ratings based on standard test procedures prescribed by the US Department of Energy.

<sup>3</sup> The TRX requires a special venting system. Use only the vent materials and methods detailed in these installation instructions.

## Part 3 - Prepare the Boiler for Installation

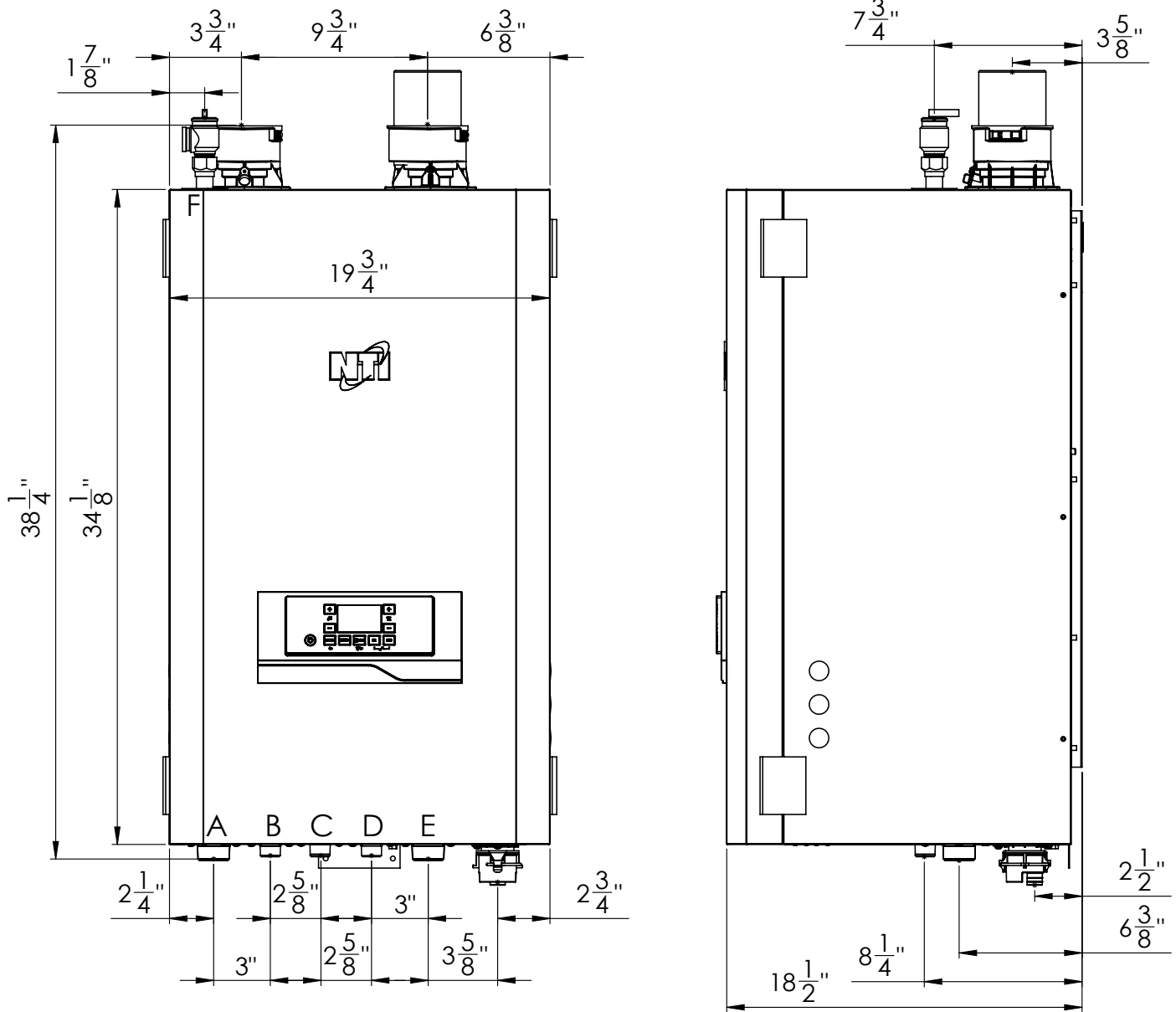
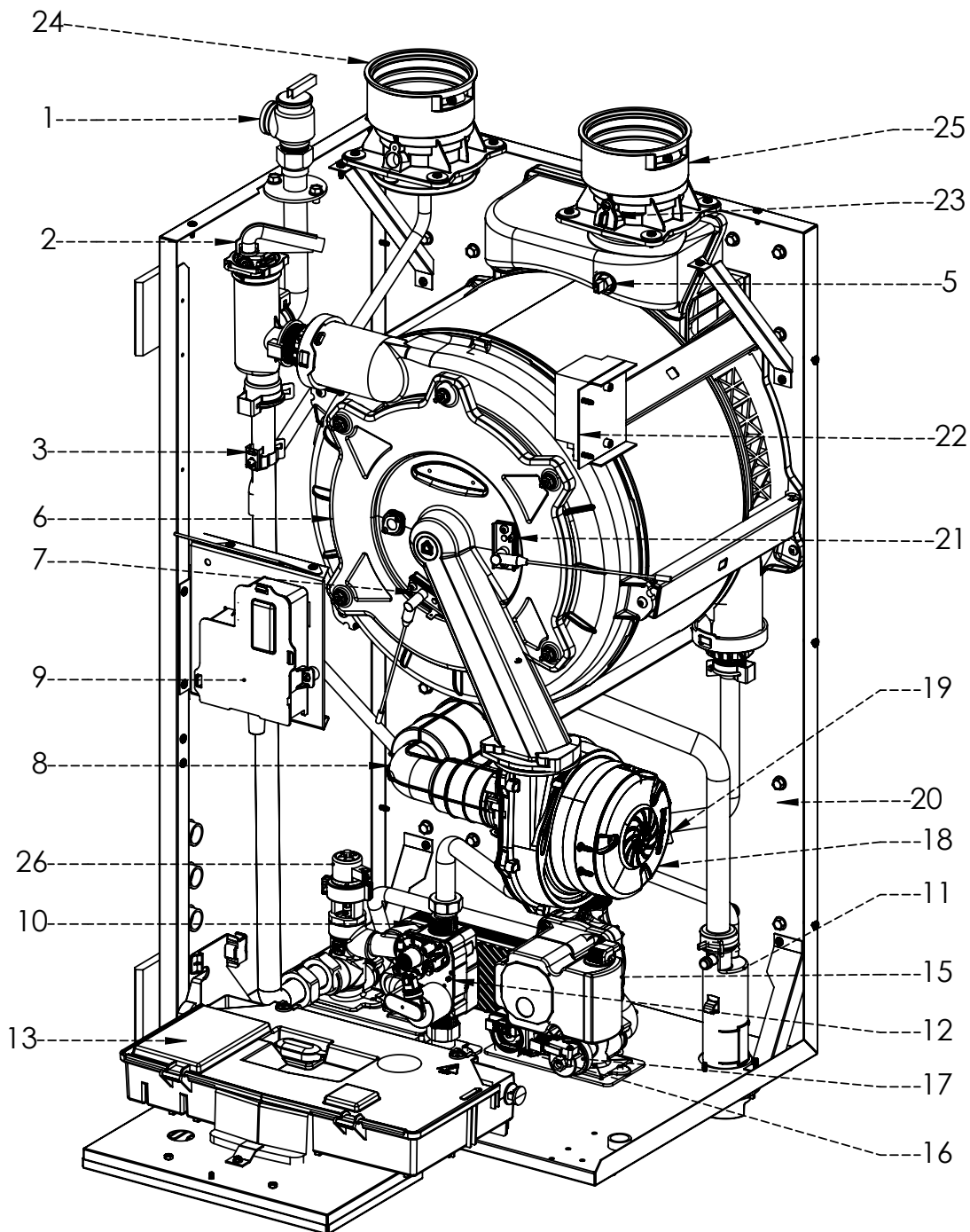

Figure 6 - Boiler Dimensions - NOTE: All Dimensions Are Approximate

Model	TRX150 and TRX199	Model	TRX199C
<b>A - Central Heating Supply</b>	1 1/4" NPT	<b>A - Central Heating Supply</b>	1 1/4" NPT
<b>B - Supply to Indirect Water Heater</b>	3/4" NPT	<b>B - Domestic Hot Water Outlet</b>	3/4" NPT
<b>C - Gas Inlet</b>	3/4" NPT	<b>C - Gas Inlet</b>	3/4" NPT
<b>D</b>	N/A	<b>D - Domestic Hot Water Inlet</b>	3/4" NPT
<b>E - Central Heating Return</b>	1 1/4" NPT	<b>E - Central Heating Return</b>	1 1/4" NPT
<b>F - Pressure Relief Valve</b>	3/4" NPT	<b>F - Pressure Relief Valve</b>	3/4" NPT

Table 8 - Boiler Connection Sizes

TRX Components



1.	Pressure relief valve	15.	Circulation Pump
2.	Air purge valve	16.	DHW Flow Sensor (Combi Models Only)
3.	Boiler outlet temperature sensor	17.	Water pressure switch
4.	Air pressure switch	18.	Modulating Fan
5.	Flue gas temperature sensor	19.	Boiler inlet temperature sensor
6.	Main heat exchanger	20.	Frame
7.	Flame detection electrode	21.	Ignition electrode
8.	Silencer	22.	Spark generator
9.	Junction box	23.	Combustion Analysis Test Point
10.	DHW Heat Exchanger (Combi Models Only)	24.	Air intake connection
11.	Condensate trap	25.	Exhaust vent connection
12.	Gas valve	26.	Diverter valve
13.	Control panel		

Figure 7 - Component Locations and Descriptions

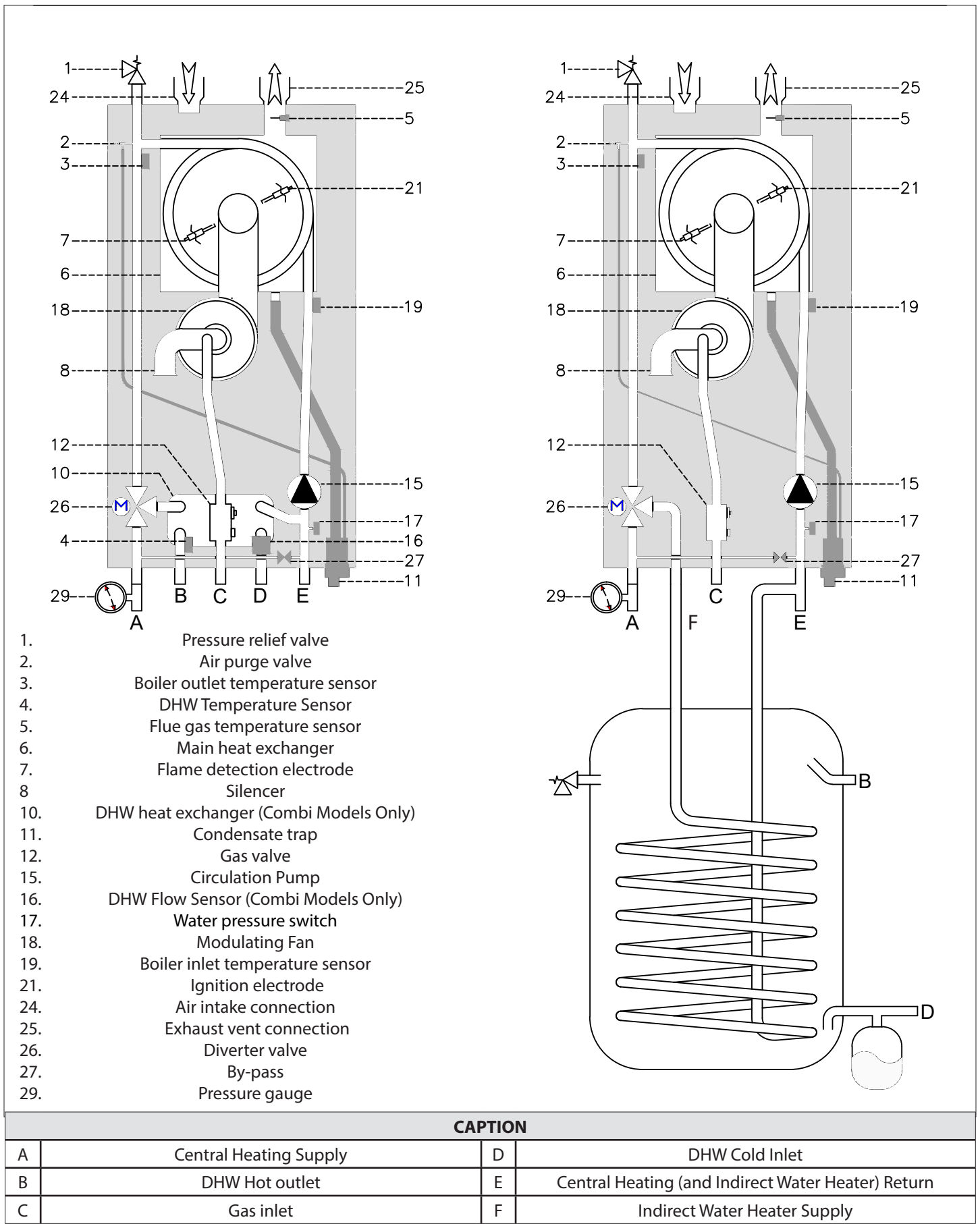

**Figure 8 - Water Circuit Diagrams**

**! WARNING**

Failure to follow the instructions in this section WILL VOID the warranty and may result in property damage, severe personal injury, or death.

The National Standard Plumbing Code, the National Plumbing Code of Canada, and the Uniform Plumbing Code limit heat transfer fluid pressure to less than the minimum working pressure of the potable water system up to 30 PSI maximum. In addition, the heat transfer fluid must be water or another non-toxic fluid having a toxicity of Class 1, as listed in Clinical Toxicology of Commercial Products, 5th Edition. Failure to follow this warning could result in property damage, severe personal injury, or death.

**CAUTION**

Do not apply a torch within 12" of the boiler. If sweat connections are used, sweat tubing to the adapter before fitting adapter to the water connections on the boiler. Damages due to improper installation practices ARE NOT covered by warranty.

Dielectric unions or galvanized steel fittings must not be used in a system with this boiler. Doing so WILL VOID the warranty. Use only copper, brass, black iron, or stainless steel fittings.

Plumbing of this product should only be done by a qualified, licensed plumber in accordance with all local plumbing codes. The boiler may be connected to an indirect water heater to supply domestic hot water. NTI offers indirect water heaters in a wide range of gallon sizes in stainless steel construction.

**A. General Plumbing Information**

**CAUTION**

The building piping system must meet or exceed the piping requirements in this manual.

Use two wrenches when tightening water piping at boiler. Use one wrench to prevent the boiler return or supply line from turning. Failure to prevent piping connections from turning could cause damage to boiler components.

The boiler control module uses temperature sensors to provide both high limit protection and modulating temperature control. The control module may also provide low water protection by sensing the water level in the heat exchanger. Some codes/jurisdictions may require additional external controls.

The water connections must be installed in accordance with all local and national plumbing codes, or any applicable standard with prevails.

- Pipe material must be suitable to meet local codes and industry standards.
- The pipe must be cleaned and without blemish before any connections are made.
- The size of the DHW pipes should be 3/4" diameter, and the CH pipes should be 1-1/4" diameter.
- Isolation (shut-off valves) should be used on both the CH and DHW loops to ease future servicing.
- All piping should be insulated.
- If the Combi Boiler is installed with a backflow preventer in the DHW cold water supply line, means shall be provided to control thermal expansion. Contact the water supplier or a local plumbing inspector on how to control this situation.

It is recommended to install a sweat shut-off valve and a union in the return and supply piping to ease future servicing. If there is a backflow preventer or any type of a no return valve in the system, install an additional tee here suitable for an expansion tank.

**NOTE:** The addition of a high temperature limiting device is important if the boiler is to be connected to a domestic hot water system.

**B. Backflow Preventer**

Use a backflow preventer specifically designed for hydronic boiler installations. This valve should be installed on the cold water fill supply line per local codes.

**C. Expansion Tank**

**Expansion Tank and Make-Up Water**

1. Ensure that the expansion tank is designed and sized to correctly handle boiler and system water volume and temperature.

**! WARNING**

Expansion tanks must be sized according to total system volume. This includes all length of pipe, all fixtures, boilers, etc. Failure to properly size for system expansion could result in wasted time, money, possible property damage, serious personal injury, or death.

**CAUTION**

Undersized expansion tanks cause system water to be lost from the relief valve, causing make-up water to be added. Eventual boiler failure can result due to excessive make-up water addition. SUCH FAILURE IS NOT COVERED BY WARRANTY.

DO NOT install automatic air vents on closed type expansion tank systems. Air must remain in the system and return to the tank to provide an air cushion. An automatic air vent would cause air to leave the system, resulting in improper operation of the expansion tank.

Model	Heat Exchanger Volume (Gallons)
TRX150	2.0
TRX199, 199C	2.7

**Table 9 - Heat Exchanger Water Volume (To Aid in Expansion Tank Sizing)**

2. The expansion tank must be located as shown in Applications, this manual, or following recognized design methods. See expansion tank manufacturer's instructions for details.
3. Connect the expansion tank to the air separator only if the air separator is on the suction side of the circulator. Always install the system fill connection at the same point as the expansion tank connection to the system.
4. Most chilled water systems are piped using a closed type expansion tank.

**DIAPHRAGM (OR BLADDER) EXPANSION TANK**

Always install an automatic air vent on top of the air separator to remove residual air from the system.

**D. Piping the Boiler**

**CAUTION**

Non-Combi Models should not be operated as a direct potable hot water heater. Only Combi Models should be used to directly heat hot water.

Use at least the MINIMUM pipe size for all appliance loop piping. This is to avoid the possibility of inadequate flow through the appliance. Using less than the required minimum pipe size and piping could result in system problems, property damage, and premature appliance failure. Such problems ARE NOT covered by product warranty.

**NOTE:** Observe the minimum 1" clearance around all uninsulated hot water pipes when openings around pipes are not protected by non-combustible materials.

## Part 4 - Water Piping

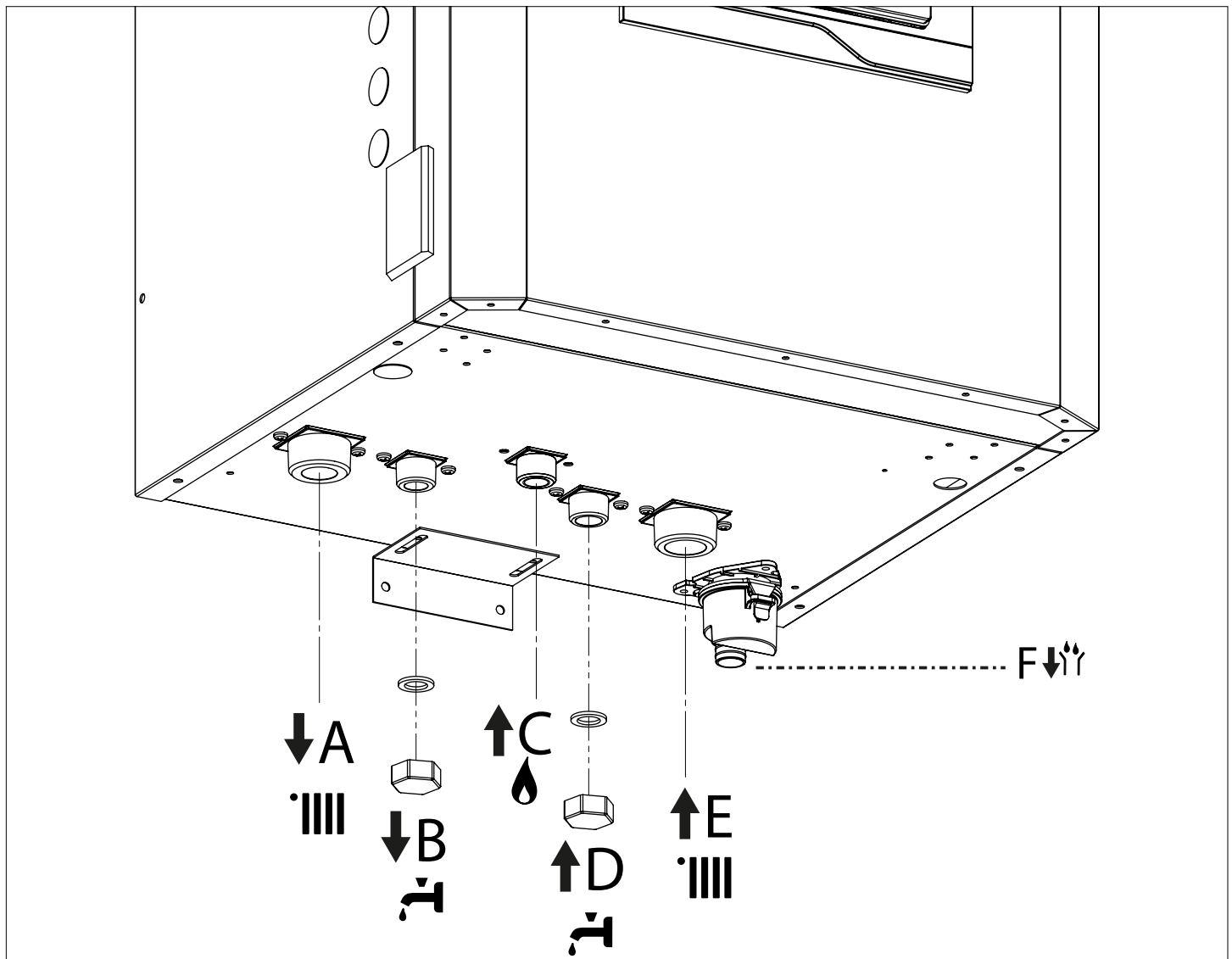

TRX150 and TRX199

TRX199C

- A. CH Supply 1-1/4"
- B. Supply to Indirect Water Heater 3/4" (Cap if not in use)
- C. Gas Inlet 3/4"
- D. N/A
- E. CH Return 1-1/4"
- F. Condensate Discharge

- A. CH Supply 1-1/4"
- B. DHW Outlet 3/4"
- C. Gas Inlet 3/4"
- D. DHW Inlet 3/4"
- E. CH Return 1-1/4"
- F. Condensate discharge

Figure 9 - Water / Gas Connections



### E. Internal Circulation Pump

To calculate the size of the heating installation refer to the graph below.

#### Graph Representing the Available Circulation Pump Head

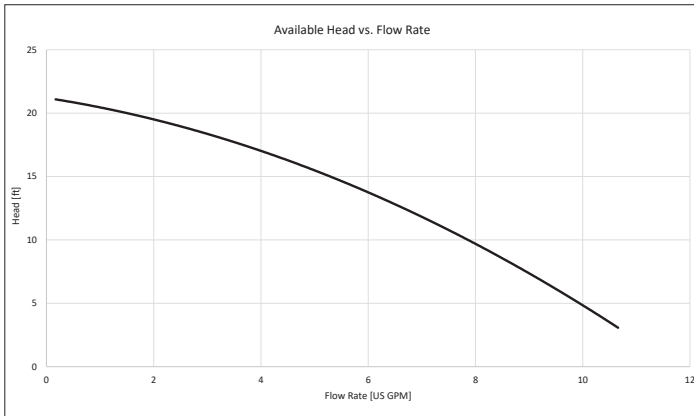

Table 10 - Internal Circulation Head Curve

## Part 4 - Water Piping

### F. CH and DHW Pressure Relief Valves

This boiler has a high-temperature shut-off switch built in as a standard safety feature. Therefore, a “pressure only” relief valve is required.

**DO NOT operate this appliance before the supplied pressure relief valve is installed with sufficient relieving capacity in accordance with the ASME rating plate on the appliance.**

#### ! WARNING

The pressure relief valve provided with the boiler must be installed as detailed in Figure 10. No other valves should be placed between the pressure relief valve and the appliance. Failure to comply with these guidelines can result in substantial property damage, personal injury, or death.

### CH Loop

This boiler is provided with a CH pressure relief valve that complies with the ANSI/ASME Boiler and Pressure Vessel Code, Section IV (Heating Boilers). The included 30 psi CH Pressure Relief Valve must be installed at the top of the boiler as illustrated below.

DO NOT install a relief valve with a pressure rating in excess of 50 psi - the maximum allowable operating pressure of the boiler. The relief valve capacity must exceed the BTU/H input capacity of the boiler. To install the pressure relief valve proceed as follows:

#### CAUTION

Use two wrenches when installing the relief valve. Use one wrench to prevent the fitting from turning. Failure to prevent the fitting from turning could cause damage to boiler components.

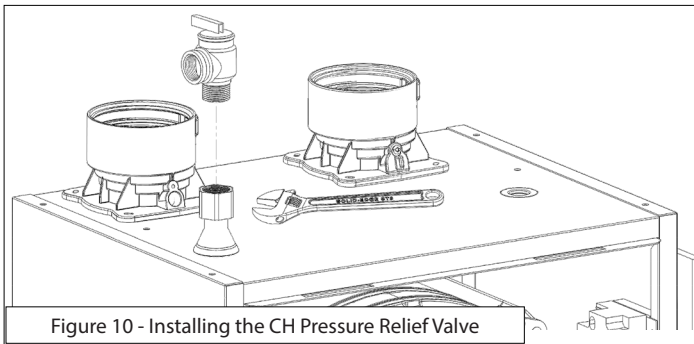

Figure 10 - Installing the CH Pressure Relief Valve

### DHW Loop (Combi Models)

The DHW piping must be provided with a DHW pressure relief valve that complies with local codes, but not less than valves certified as meeting the requirements of Relief Valves for Hot Water Supply Systems, ANSI Z21.22 / CSA4.4 by a nationally recognized lab that maintains periodic inspection of production listed equipment.

A DHW pressure relief valve is not included with the boiler, and is to be field supplied and installed in the DHW piping. DO NOT install a DHW relief valve with a pressure rating greater than 150 psi - the maximum allowable operating pressure of the boiler's DHW circuit.

After installing the relief valves and filling and pressurizing the system, test the operation of the valves by lifting the levers.

Make sure the valves discharge freely. If a valve fails to operate correctly, replace it with a new relief valve.

The relief valve capacity must exceed the BTU/H input capacity of the boiler.

#### ! WARNING

To avoid water damage or scalding due to relief valve operation:

- Discharge line must be connected to relief valve outlet and run to a safe place of disposal. Terminate the discharge line in a manner that will prevent possibility of severe burns or property damage should the relief valve discharge.
- Discharge line must be as short as possible and the same size as the valve discharge connection throughout its entire length.
- Discharge line must pitch downward from the valve and terminate at least 6” above the floor drain, making discharge clearly visible.
- The discharge line shall terminate plain, not threaded, with a material serviceable for temperatures of 375°F or greater.
- Do not pipe discharge to any location where freezing could occur.
- No valve may be installed between the relief valve and boiler or in the discharge line. Do not plug or place any obstruction in the discharge line.
- Test the operation of the relief valve after filling and pressurizing the system by lifting the lever. Make sure the valve discharges freely. If the valve fails to operate correctly, immediately replace with a new properly rated relief valve.
- Test relief valve at least once annually to ensure the waterway is clear. If valve does not operate, turn the boiler “off” and call a plumber immediately.
- Take care whenever operating relief valve to avoid scalding injury or property damage.

FAILURE TO COMPLY WITH THE ABOVE GUIDELINES COULD RESULT IN FAILURE OF RELIEF VALVE OPERATION, RESULTING IN POSSIBILITY OF SUBSTANTIAL PROPERTY DAMAGE, SEVERE PERSONAL INJURY, OR DEATH.

Do not thread a cap or plug into the relief valve or relief valve line under any circumstances! Explosion and property damage, serious injury, or death may result.

RE-INSPECTION OF RELIEF VALVES: Relief valves should be inspected AT LEAST ONCE EVERY THREE YEARS, and replaced if necessary, by a licensed plumbing contractor or qualified service technician to ensure that the product has not been affected by corrosive water conditions and to ensure that the valve and discharge line have not been altered or tampered with illegally. Certain naturally occurring conditions may corrode the valve and its components over time, rendering the valve inoperative. Such conditions can only be detected if the valve and its components are physically removed and inspected. Do not attempt to conduct an inspection on your own. Contact your plumbing contractor for a re-inspection to assure continued safety.

FAILURE TO RE-INSPECT THE RELIEF VALVE AS DIRECTED COULD RESULT IN UNSAFE TEMPERATURE AND/OR PRESSURE BUILD-UP WHICH CAN RESULT IN PROPERTY DAMAGE, SERIOUS PERSONAL INJURY, OR DEATH.

**G. Air Elimination Device**

A micro bubble air elimination device must be installed in every boiler installation. Automatic air vents alone are not an acceptable substitute for a micro bubble air elimination device. Here are a few examples of acceptable devices.

- Spirovent
- TACO 4900 Series
- Caleffi Discal

**H. Low Water Cut-Off (Field Supplied)**

This boiler is provided with a factory installed Water Pressure Switch. In the event water pressure drops below 7 PSI, the control will go to a blocking error "FILL - 108", inhibiting burner operation.

However, a low water cut-off may be required by local codes. This is to be remote-mounted and field supplied. See Figure 11 for basic Low Water Cut-Off installation instructions. Do not install an isolation valve between boiler and low water cut-off.

When wiring the low water cut-off follow the installation instructions provided by the low water cut-off manufacturer.

**NOTE:** During a low water condition, the field supplied low water cut-off normally open contacts must break the main power supply to the boiler. Failure to follow this instruction will defeat the purpose of a low water cut-off and will result in damage to the boiler. Such damages are not covered by boiler warranty.

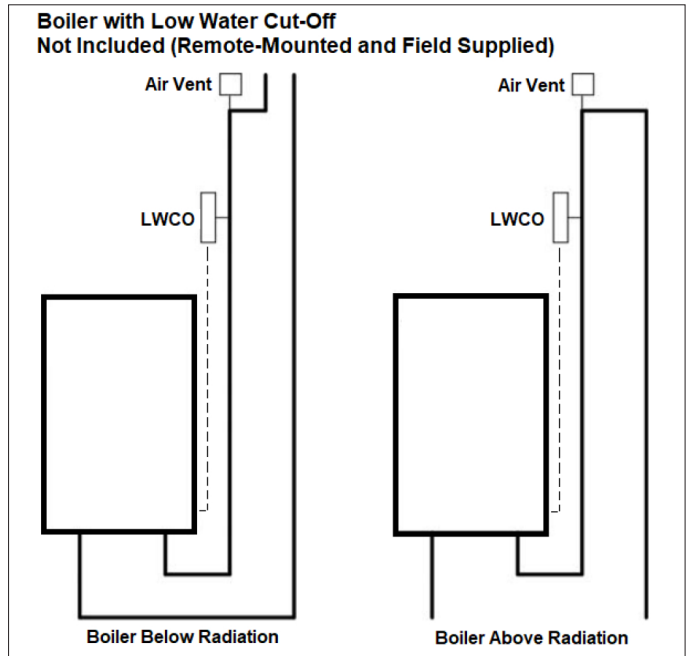

Figure 11 - Low Water Cut-Off Basic Installation

**I. Applications\***

**CAUTION**

In mixed temperature applications, mixing valves are required for the protection of low temperature loops.

LEGEND

SYMBOL	DESCRIPTION	SYMBOL	DESCRIPTION	SYMBOL	DESCRIPTION	SYMBOL	DESCRIPTION
	central air separator		isolation valve		check valve		pressure & temperature valve
	temp/press guage		circulator w/ isolation flanges		union		auto air vent
	expansion tank		pressure reducing valve		strainer		zone load
	backflow preventor		pressure relief valve		zone valve		drain valve

Figure 12 - Piping Symbol Legend

## Part 4 - Water Piping

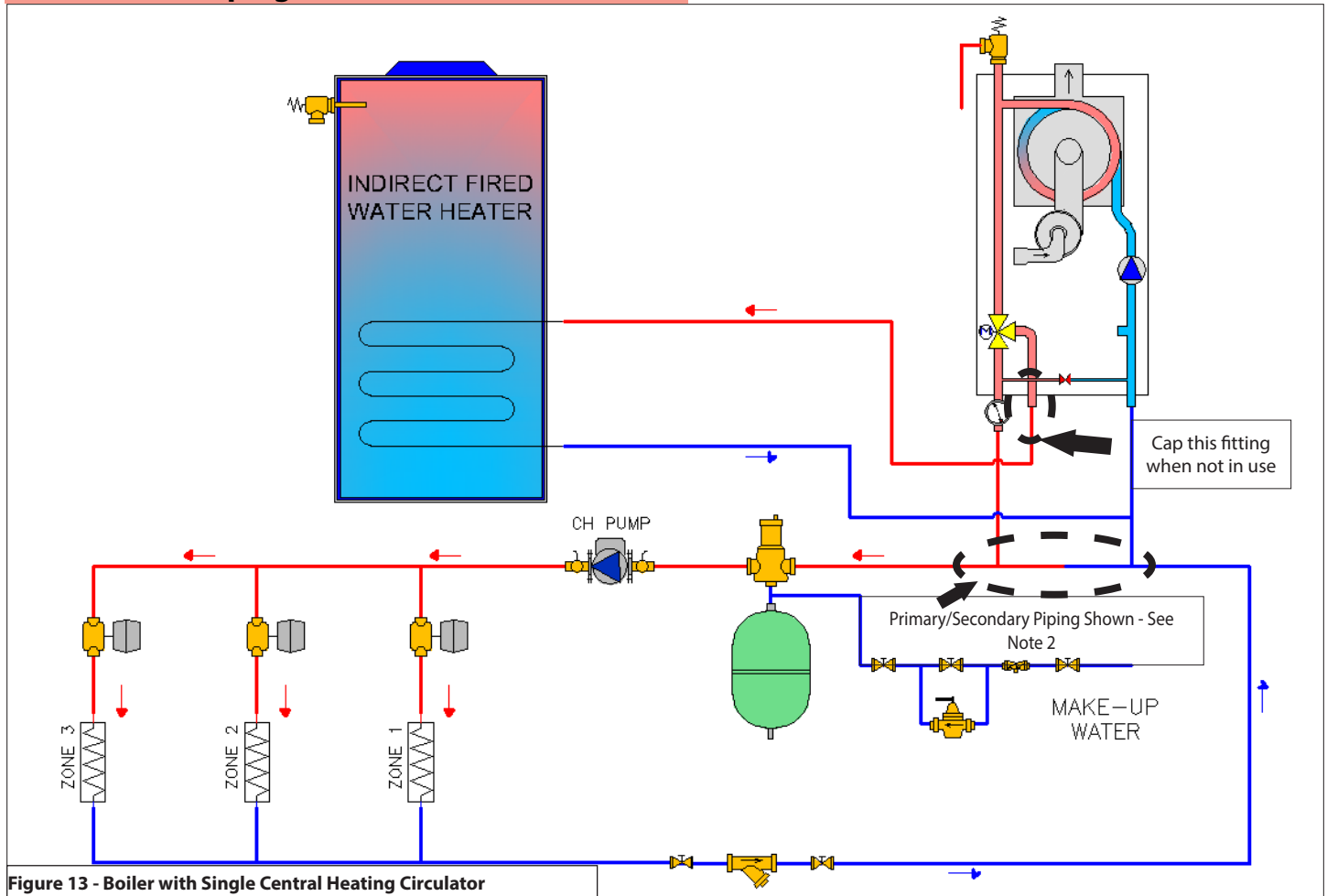

Figure 13 - Boiler with Single Central Heating Circulator

**NOTE:** In piping applications utilizing a single zone, it is recommended that the installer use flow / check valves with weighted seats at or near the appliance to prevent gravity circulation.

### NOTICE

Figure illustrates the basic plumbing requirements for a TRX150 / TRX199 boiler installation utilizing Primary/Secondary piping when the boiler circulator will not provide adequate flow for the system. Primary / Secondary is required to provide adequate flow for the secondary circuits.

### CAUTION

On TRX150 / TRX199 Models Only.  
If the boiler is to be used only in Heating Mode (not connected to an indirect water heater), cap the fitting as indicated in the figure above. A cap is included with the boiler. The electrical connection of the 3-way valve motor **MUST BE DISCONNECTED** while the boiler is operating in central heating mode. This will lock the valve motor in central heating mode and ensure freeze protection operates properly. Failure to disconnect the valve may disable boiler freeze protection and result in property damage.

### ! WARNING

The piping will not support the weight of the circulators. Refer to the circulator manufacturer's instructions to properly support the circulator. Failure to comply with these instructions could result in property damage, severe personal injury, or death.

### NOTES:

1. This drawing is meant to show system piping concept only. Installer is responsible for all equipment and detailing required by local codes.
2. Primary / Secondary Loop: All closely spaced tees shall be within 4 pipe diameters center to center spacing.
3. A minimum of 6 pipe diameters of straight pipe shall be installed upstream and downstream of all closely spaced tees.
4. The minimum pipe size of DHW piping should be  $\frac{3}{4}$ " diameter and CH piping should be 1" in diameter.
5. Circulators are shown with isolation flanges. The alternative is standard flanges with full port ball valves. Purge valves can be used with circulator flanges as an alternative.
6. Piping shown is Primary/Secondary.
7. Install a minimum of 12 diameters of straight pipe upstream of all circulators.
8. **VERY IMPORTANT** - Minimum flow rates outlined in this manual (2 gpm) must be maintained through the heat exchanger to minimize short cycling.
9. In a valve-based system, each heating zone has a zone valve which opens when that zone calls for heat. Each zone thermostat is wired to its corresponding zone valve. Contacts in the zone valves provide a signal to the boiler to operate when there is a call for heat.
10. **Unit is equipped with built-in primary pump.** This pump is sized to ensure proper flow rate through the boiler heat exchanger and related piping.
11. IWH Applications - a mixing valve is recommended if the DHW temperature is set above 119°F.

**! WARNING**

For direct (not primary / secondary) piping applications, the expansion vessel must be placed on the return side of the boiler as illustrated. Placement of flow restricting devices, such as check valves, is prohibited between the boiler return and the expansion vessel. Failure to place the expansion vessel as instructed, may result in the release of the pressure relief valve, property damage, severe personal injury, or death.

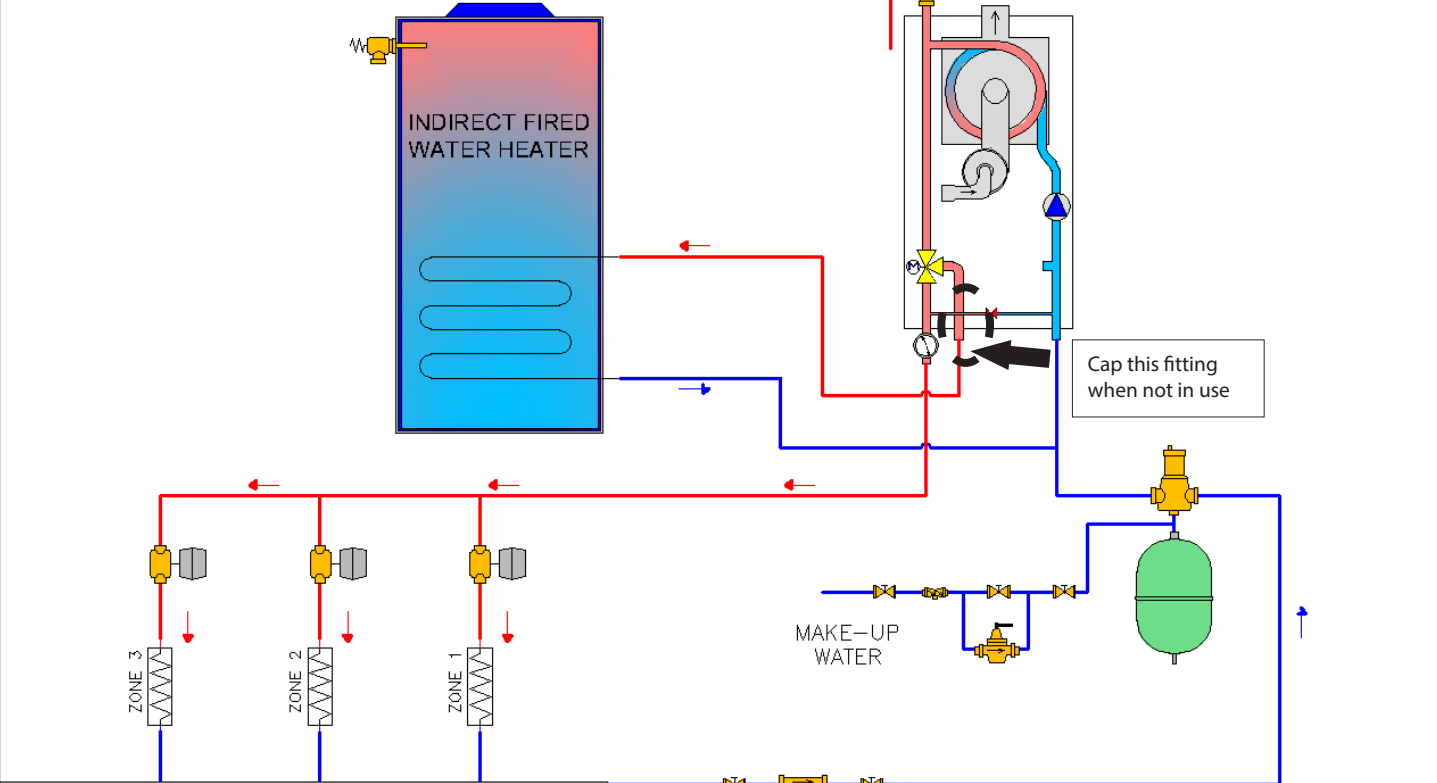

**Figure 14 - Boiler without Central Heating Circulator**

**NOTE:** In piping applications utilizing a single zone, it is recommended that the installer use flow / check valves with weighted seats at or near the appliance to prevent gravity circulation.

**NOTICE**

Figure illustrates the basic plumbing requirements for a TRX150 / TRX199 boiler installation without an external Central Heating circulator; the boiler's internal circulator delivers flow to the heating system. Application is limited to zone valve (or non-circulator) distribution systems with small flow requirements (e.g. systems requiring no more than 9 gpm at 9 ft. of head pressure).

**CAUTION**

On TRX150 / TRX199 Models Only.  
If the boiler is to be used only in Heating Mode (not connected to an indirect water heater), cap the fitting as indicated in the figure above. A cap is included with the boiler. The electrical connection of the 3-way valve motor **MUST BE DISCONNECTED** while the boiler is operating in central heating mode. This will lock the valve motor in central heating mode and ensure freeze protection operates properly. Failure to disconnect the valve may disable boiler freeze protection and result in property damage.

**! WARNING**

The piping will not support the weight of the circulators. Refer to the circulator manufacturer's instructions to properly support the circulator. Failure to comply with these instructions could result in property damage, severe personal injury, or death.

**NOTES:**

1. This drawing is meant to show system piping concept only. Installer is responsible for all equipment and detailing required by local codes.
2. The minimum pipe size of DHW piping should be 3/4" diameter and CH piping should be 1" in diameter.
3. Circulators are shown with isolation flanges. The alternative is standard flanges with full port ball valves. Purge valves can be used with circulator flanges as an alternative.
4. Install a minimum of 12 diameters of straight pipe upstream of all circulators.
5. **VERY IMPORTANT** - Minimum flow rates outlined in this manual (2 gpm) must be maintained through the heat exchanger to minimize short cycling.
6. In a valve-based system, each heating zone has a zone valve which opens when that zone calls for heat. Each zone thermostat is wired to its corresponding zone valve. Contacts in the zone valves provide a signal to the boiler to operate when there is a call for heat.
7. **Unit is equipped with built-in primary pump for the heating loop.** This pump is sized to ensure proper flow rate through the boiler heat exchanger and related piping.
8. IWH Applications - a mixing valve is recommended if the DHW temperature is set above 119°F.
9. For direct (not primary / secondary) piping applications, it is required to install the expansion vessel on the return side of the boiler as illustrated.

## Part 4 - Water Piping

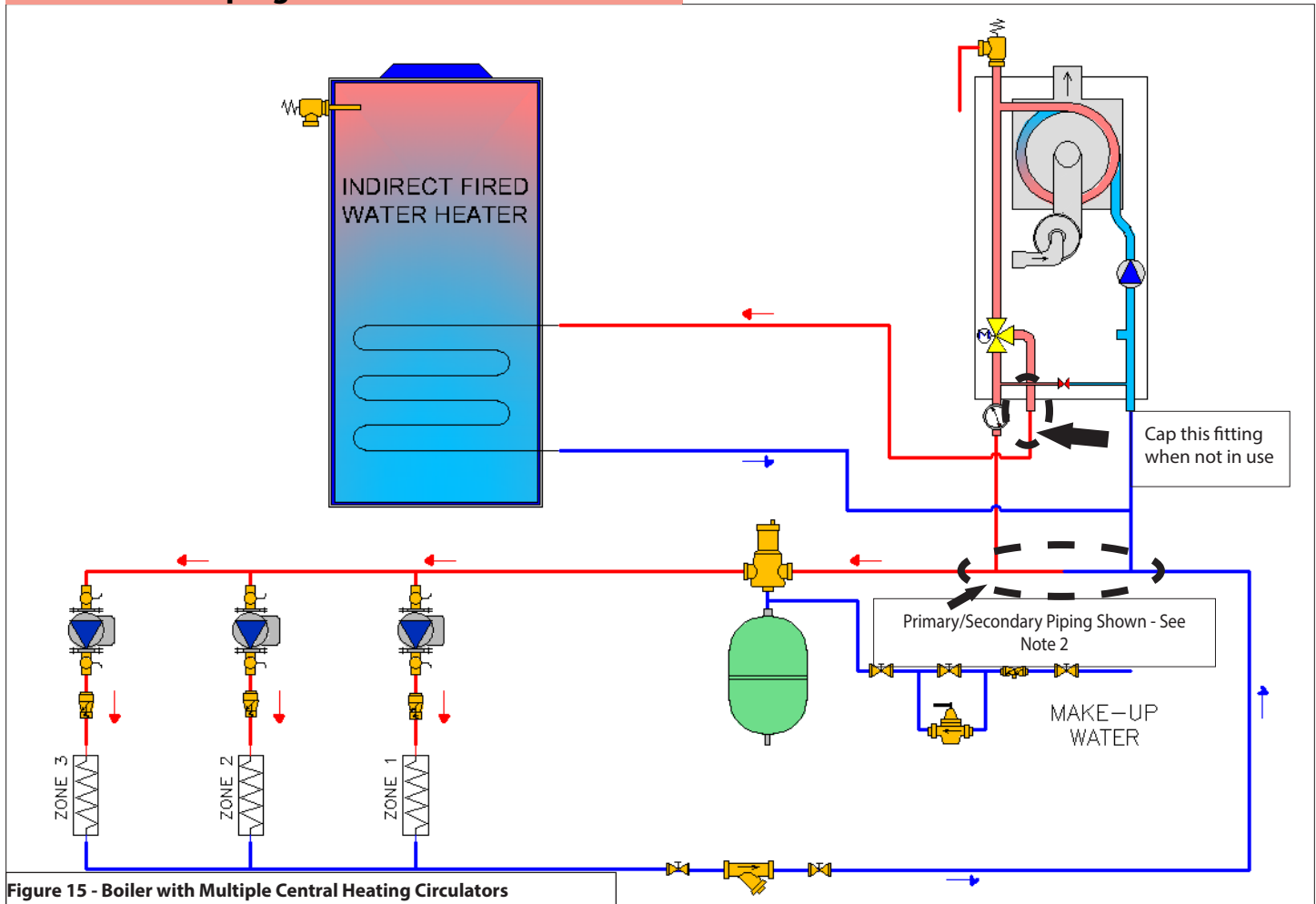

Figure 15 - Boiler with Multiple Central Heating Circulators

**NOTE:** In piping applications utilizing a single zone, it is recommended that the installer use flow / check valves with weighted seats at or near the appliance to prevent gravity circulation.

### NOTICE

Figure illustrates the basic plumbing requirements for a TRX150 / TRX199 boiler installation utilizing Primary/Secondary piping when the boiler circulator will not provide adequate flow for the system. Primary / Secondary is required to provide adequate flow for the secondary circuits.

### CAUTION

On TRX150 / TRX199 Models Only.  
If the boiler is to be used only in Heating Mode (not connected to an indirect water heater), cap the fitting as indicated in the figure above. A cap is included with the boiler. The electrical connection of the 3-way valve motor **MUST BE DISCONNECTED** while the boiler is operating in central heating mode. This will lock the valve motor in central heating mode and ensure freeze protection operates properly. Failure to disconnect the valve may disable boiler freeze protection and result in property damage.

### ! WARNING

The piping will not support the weight of the circulators. Refer to the circulator manufacturer's instructions to properly support the circulator. Failure to comply with these instructions could result in property damage, severe personal injury, or death.

### NOTES:

1. This drawing is meant to show system piping concept only. Installer is responsible for all equipment and detailing required by local codes.
2. Primary / Secondary Loop: All closely spaced tees shall be within 4 pipe diameters center to center spacing.
3. A minimum of 6 pipe diameters of straight pipe shall be installed upstream and downstream of all closely spaced tees.
4. The minimum pipe size of DHW piping should be  $\frac{3}{4}$ " diameter and CH piping should be 1" in diameter.
5. Circulators are shown with isolation flanges. The alternative is standard flanges with full port ball valves. Purge valves can be used with circulator flanges as an alternative.
6. Piping shown is Primary/Secondary.
7. Install a minimum of 12 diameters of straight pipe upstream of all circulators.
8. **VERY IMPORTANT** - Minimum flow rates outlined in this manual (2 gpm) must be maintained through the heat exchanger to minimize short cycling.
9. In a valve-based system, each heating zone has a zone valve which opens when that zone calls for heat. Each zone thermostat is wired to its corresponding zone valve. Contacts in the zone valves provide a signal to the boiler to operate when there is a call for heat.
10. **Unit is equipped with built-in primary pump.** This pump is sized to ensure proper flow rate through the boiler heat exchanger and related piping.
11. IWH Applications - a mixing valve is recommended if the DHW temperature is set above 119°F.



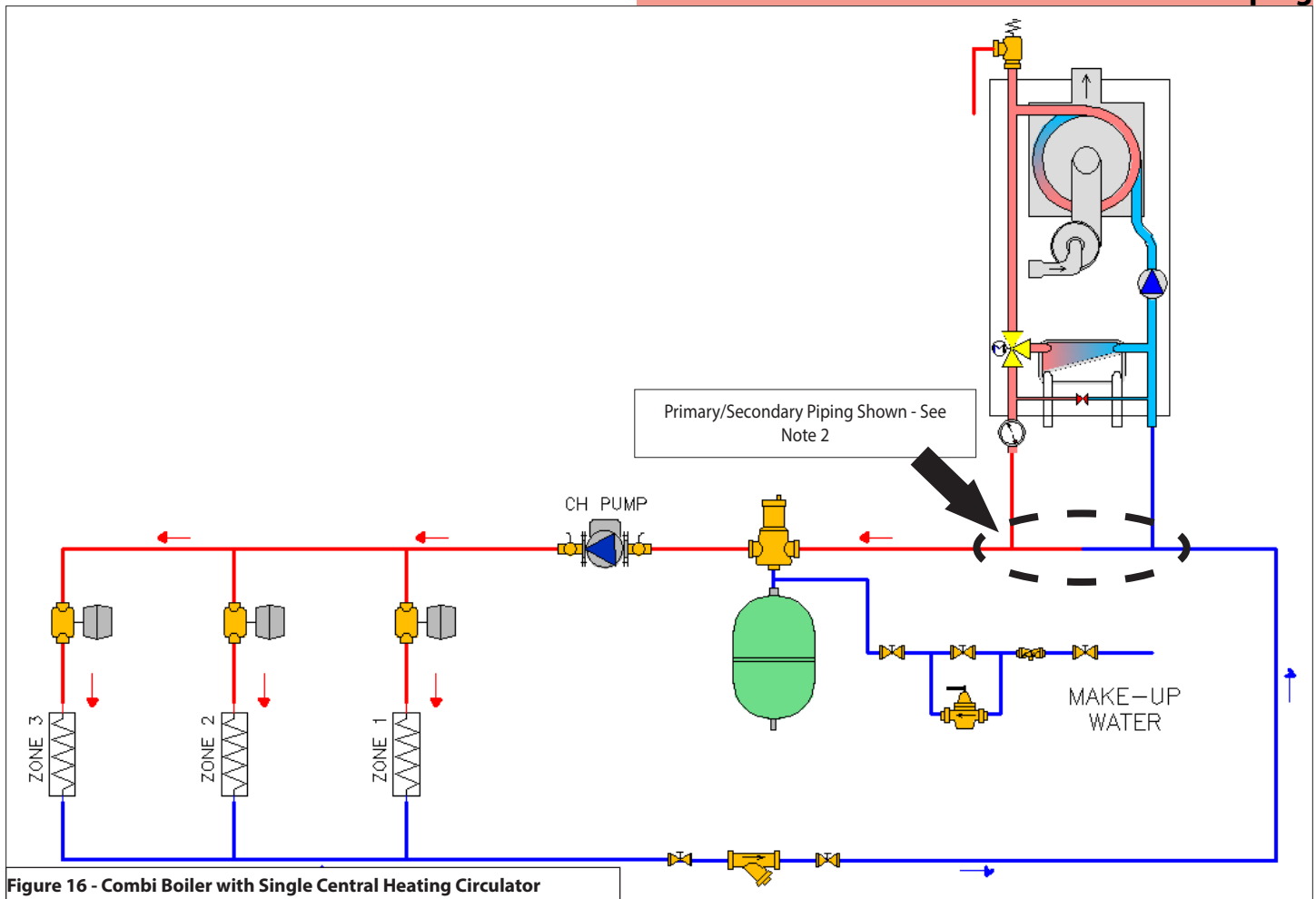

Figure 16 - Combi Boiler with Single Central Heating Circulator

**NOTE:** In piping applications utilizing a single zone, it is recommended that the installer use flow / check valves with weighted seats at or near the appliance to prevent gravity circulation.

**NOTICE**

Figure illustrates the basic plumbing requirements for a TRX199C boiler installation utilizing Primary/Secondary piping when the boiler circulator will not provide adequate flow for the system. Primary / Secondary is required to provide adequate flow for the secondary circuits.

**! WARNING**

The piping will not support the weight of the circulators. Refer to the circulator manufacturer's instructions to properly support the circulator. Failure to comply with these instructions could result in property damage, severe personal injury, or death.

**NOTES:**

1. This drawing is meant to show system piping concept only. Installer is responsible for all equipment and detailing required by local codes.
2. Primary / Secondary Loop: All closely spaced tees shall be within 4 pipe diameters center to center spacing.
3. A minimum of 6 pipe diameters of straight pipe shall be installed upstream and downstream of all closely spaced tees.
4. The minimum pipe size of DHW piping should be 3/4" diameter and CH piping should be 1" in diameter.
5. Circulators are shown with isolation flanges. The alternative is standard flanges with full port ball valves. Purge valves can be used with circulator flanges as an alternative.
6. Install a minimum of 12 diameters of straight pipe upstream of all circulators.
7. **VERY IMPORTANT** - Minimum flow rates outlined in this manual (2 gpm) must be maintained through the heat exchanger to minimize short cycling.
8. In a valve-based system, each heating zone has a zone valve which opens when that zone calls for heat. Each zone thermostat is wired to its corresponding zone valve. Contacts in the zone valves provide a signal to the boiler to operate when there is a call for heat.
9. **Unit is equipped with built-in primary pump.** This pump is sized to ensure proper flow rate through the boiler heat exchanger and related piping.

## Part 4 - Water Piping

### ! WARNING

For direct (not primary / secondary) piping applications, the expansion vessel must be placed on the return side of the boiler as illustrated. Placement of flow restricting devices, such as check valves, is prohibited between the boiler return and the expansion vessel. Failure to place the expansion vessel as instructed, may result in the release of the pressure relief valve, property damage, severe personal injury, or death.

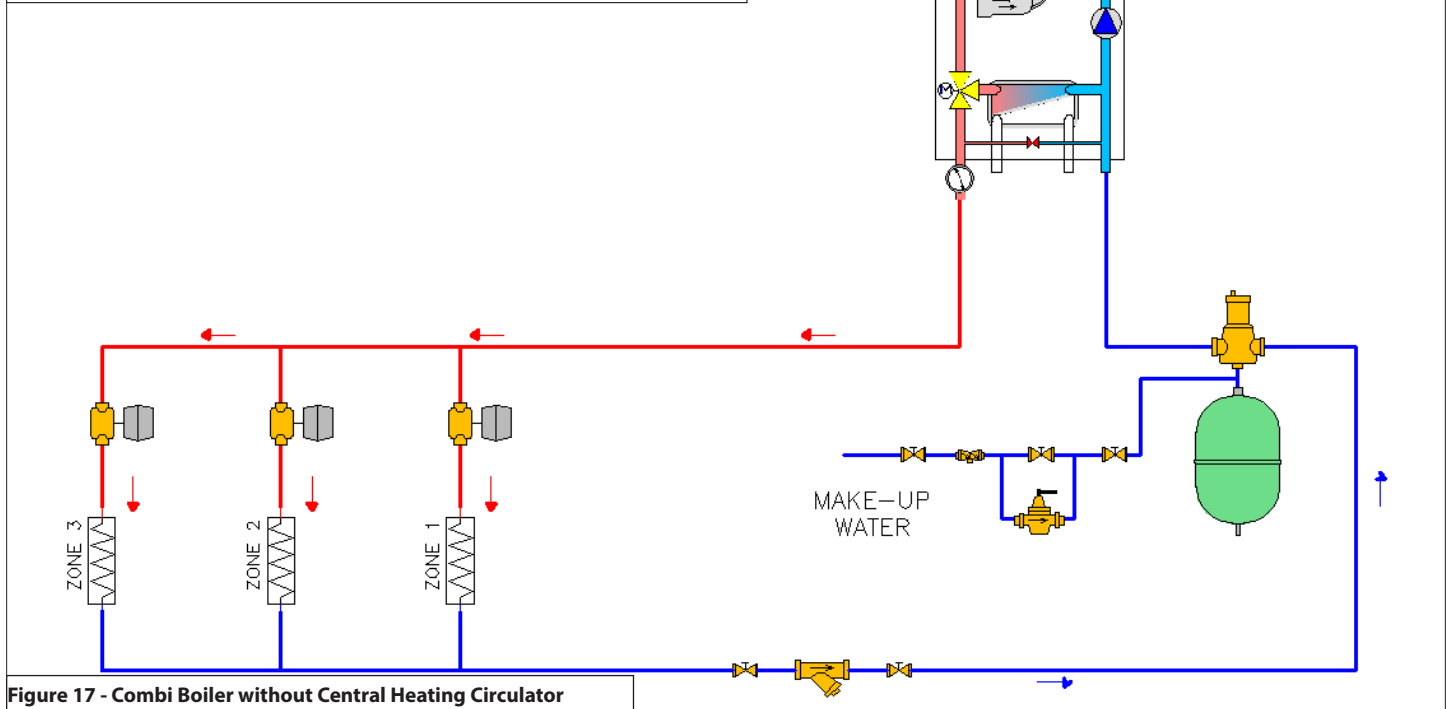

Figure 17 - Combi Boiler without Central Heating Circulator

**NOTE:** In piping applications utilizing a single zone, it is recommended that the installer use flow / check valves with weighted seats at or near the appliance to prevent gravity circulation.

### NOTICE

Figure illustrates the basic plumbing requirements for a TRX199C boiler installation without an external Central Heating circulator; the boiler's internal circulator delivers flow to the heating system. Application is limited to zone valve (or non-circulator) distribution systems with small flow requirements (e.g. systems requiring no more than 9 gpm at 9 ft. of head pressure).

### ! WARNING

The piping will not support the weight of the circulators. Refer to the circulator manufacturer's instructions to properly support the circulator. Failure to comply with these instructions could result in property damage, severe personal injury, or death.

### NOTES:

1. This drawing is meant to show system piping concept only. Installer is responsible for all equipment and detailing required by local codes.
2. The minimum pipe size of DHW piping should be  $\frac{3}{4}$ " diameter and CH piping should be 1" in diameter.
3. Circulators are shown with isolation flanges. The alternative is standard flanges with full port ball valves. Purge valves can be used with circulator flanges as an alternative.
4. Install a minimum of 12 diameters of straight pipe upstream of all circulators.
5. **VERY IMPORTANT** - Minimum flow rates outlined in this manual (2 gpm) must be maintained through the heat exchanger to minimize short cycling.
6. In a valve-based system, each heating zone has a zone valve which opens when that zone calls for heat. Each zone thermostat is wired to its corresponding zone valve. Contacts in the zone valves provide a signal to the boiler to operate when there is a call for heat.
7. **Unit is equipped with built-in primary pump for the heating loop.** This pump is sized to ensure proper flow rate through the boiler heat exchanger and related piping.
8. For direct (not primary / secondary) piping applications, it is required to install the expansion vessel on the return side of the boiler as illustrated.

## CAUTION

In mixed temperature applications, mixing valves are required for the protection of low temperature loops.

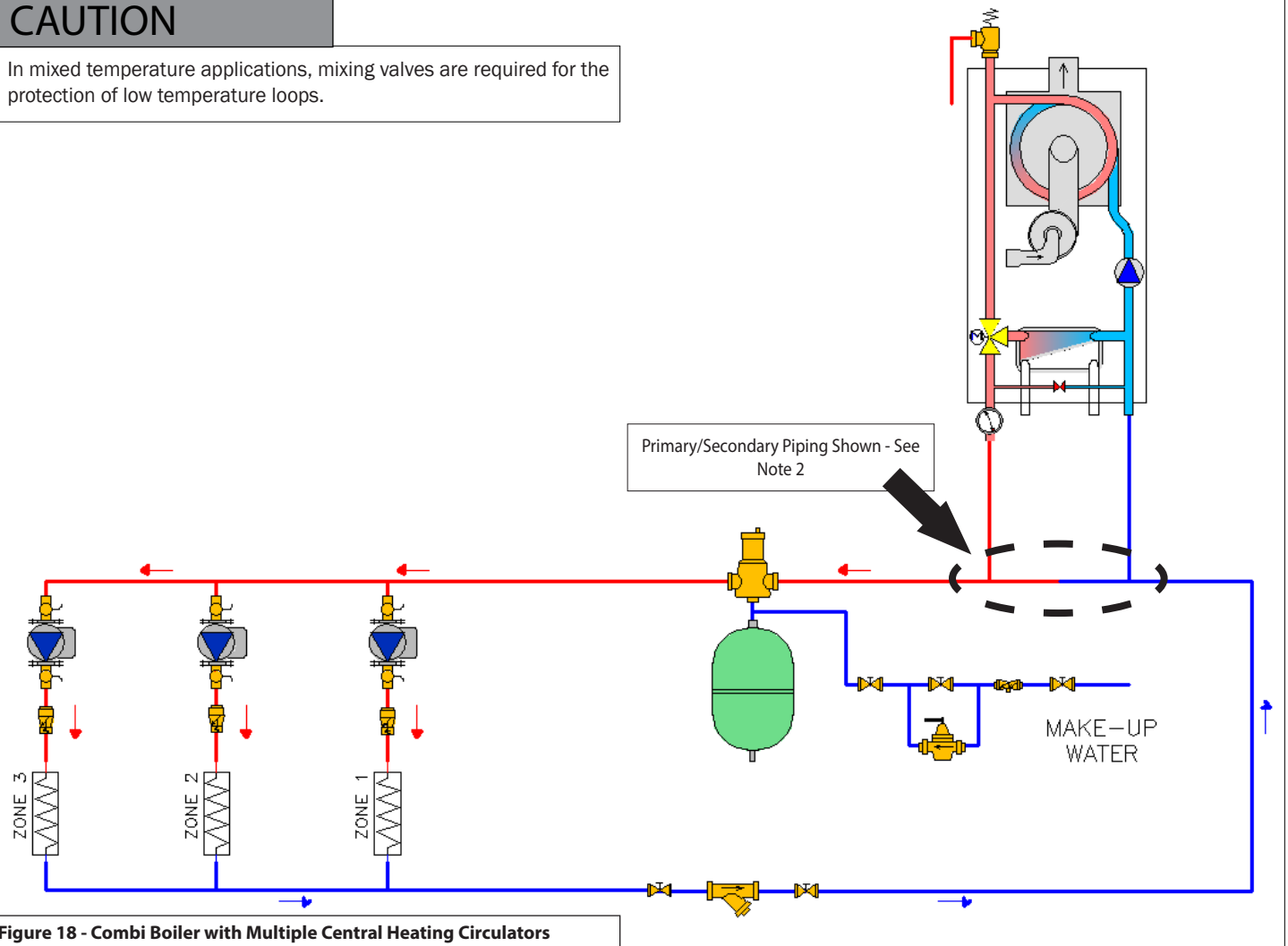

Figure 18 - Combi Boiler with Multiple Central Heating Circulators

**NOTE:** In piping applications utilizing a single zone, it is recommended that the installer use flow / check valves with weighted seats at or near the appliance to prevent gravity circulation.

## NOTICE

Figure illustrates the basic plumbing requirements for a TRX199C boiler installation utilizing Primary/Secondary piping when the boiler circulator will not provide adequate flow for the system. Primary / Secondary is required to provide adequate flow for the secondary circuits.

## ! WARNING

The piping will not support the weight of the circulators. Refer to the circulator manufacturer's instructions to properly support the circulator. Failure to comply with these instructions could result in property damage, severe personal injury, or death.

### NOTES:

1. This drawing is meant to show system piping concept only. Installer is responsible for all equipment and detailing required by local codes.
2. Primary / Secondary Loop: All closely spaced tees shall be within 4 pipe diameters center to center spacing.
3. A minimum of 6 pipe diameters of straight pipe shall be installed upstream and downstream of all closely spaced tees.
4. The minimum pipe size of DHW piping should be  $\frac{3}{4}$ " diameter and CH piping should be 1" in diameter.
5. Circulators are shown with isolation flanges. The alternative is standard flanges with full port ball valves. Purge valves can be used with circulator flanges as an alternative.
6. Install a minimum of 12 diameters of straight pipe upstream of all circulators.
7. **VERY IMPORTANT** – Minimum flow rates outlined in this manual (2 gpm) must be maintained through the heat exchanger to minimize short cycling.
8. In a valve-based system, each heating zone has a zone valve which opens when that zone calls for heat. Each zone thermostat is wired to its corresponding zone valve. Contacts in the zone valves provide a signal to the boiler to operate when there is a call for heat.
9. **Unit is equipped with built-in primary pump.** This pump is sized to ensure proper flow rate through the boiler heat exchanger and related piping.

## Part 4 - Water Piping

### J. Floor Drying Function

The Floor Drying Function is a special function that allows the installer, through a dedicated heating cycle, to use the boiler for drying a freshly poured radiant floor during a floor system installation.

The installer can set parameter 2.7.4 (Floor Drying Cycle) and choose the cycle's operation (Functional Heating, Curing Heating, a combination of Functional and Curing Heating, or Manual Heating).

This function can follow different flow temperature profiles according to the parameter 2.7.4 values:

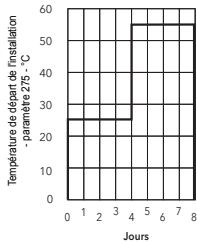
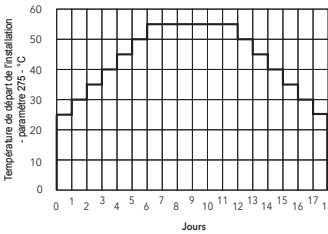
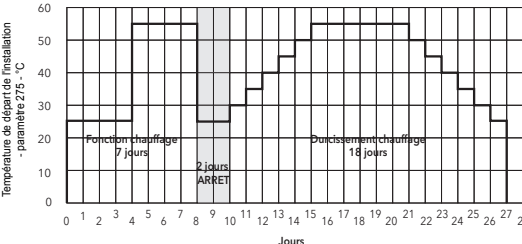
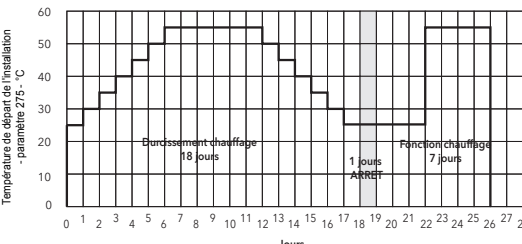
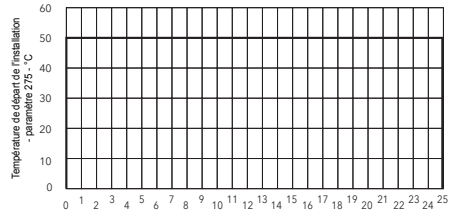
Value	Function mode description
0	OFF
1	 <p><b>Functional Heating:</b> The supply setpoint temperature is kept at 77°F for three (3) days, then increased to the target temperature (parameter 2.7.5 - default = 131°F) and kept at this temperature for four (4) days.</p>
2	 <p><b>Curing Heating:</b> Supply setpoint temperature increases from 77°F to the target temperature (defined by parameter 2.7.5) by 5F/day, stays at target temperature (defined by parameter 2.7.5) for "x" days, and decreases from target temperature to 77°F by 5F/day for a fixed total amount of days to 18. Example 1: Parameter 2.7.5 = 131°F; increasing phase from 77°F to 131°F = 6 days; stays at 131°F for 6 days; decreasing phase from 131°F to 77°F = 6 days. Example 2: Parameter 2.7.5 = 140°F; increasing phase from 77°F to 140°F = 7 days; stays at 140°F for 4 days; decreasing phase from 140°F to 77°F = 7 days.</p>
3	 <p><b>Functional Heating + Curing Heating:</b> The two operation modes are executed consecutively with a stop period of two (2) days in between.</p>
4	 <p><b>Curing Heating + Functional Heating:</b> The two operation modes are executed consecutively with a stop period of one (1) day in between.</p>
5	 <p><b>Manual Heating:</b> The supply setpoint temperature is fixed at the value defined by the parameter 2.7.5 "Floor Drying Flow Setpoint Temperature".</p>

**! DANGER**

The boiler must be vented as detailed in this section. Ensure exhaust vent and intake piping complies with these instructions regarding vent system. Inspect finished exhaust vent and intake piping thoroughly to ensure all joints are well secured, airtight, and comply with all applicable code requirements, as well as the instructions provided in this manual. Failure to properly install the vent system will result in severe personal injury or death.

**A. General****! DANGER**

This boiler is certified as a "Category IV" appliance and requires a special venting system. The vent system will operate with a positive pressure in the pipe. Exhaust gases must be piped directly outdoors using the vent materials and rules outlined in these instructions. Do not connect vent connectors serving appliances vented by natural draft into any portion of mechanical draft systems operating under positive pressure. Follow the venting instructions carefully. Failure to do so will result in substantial property damage, severe personal injury, or death.

Exhaust and intake are to be piped separately. This boiler cannot share a common exhaust or intake with multiple appliances. Failure to follow these instructions will result in substantial property damage, severe personal injury, or death.

1. Installation should be made in accordance with the regulations of the Authority Having Jurisdiction, local code authorities, and utility companies which pertain to this type of water heating equipment.
2. Install the venting system in accordance with these instructions and with the National Fuel Gas Code, ANSI Z223.1/NFPA 54, CAN/CGA B149, and / or applicable provisions of local building codes.
3. This boiler must be vented with materials, components, and systems listed and approved for Category IV appliances.

**NOTE:** To avoid contamination often contained in indoor air, it is best to pipe all intake combustion air directly to the outdoors.

**NOTE:** Care must be taken to prevent condensate freezing in the exhaust vent pipe system. See local, state, provincial, and national codes for best practices to prevent condensate freezing in the exhaust vent pipe system.

**! WARNING**

Improper seating of vent pipe gaskets can cause eventual gasket failure and exhaust gas leakage. Ensure the exhaust vent pipe is properly beveled and seated before insertion into the flue adapter. Failure to do so could result in property damage, severe personal injury, or death.

Exhaust vent connections are not designed as load-bearing devices, and must not be used to support exhaust vent piping. All vent pipes must be properly connected, supported, and the exhaust vent must be pitched a minimum of 1/4" per foot back to the boiler to allow drainage of condensate. Failure to properly support vent piping and follow the information in this statement could result in product damage, severe personal injury, or death.

It is required to insert the provided exhaust and intake screens into the vent terminations to prevent blockage caused by debris or birds. Failure to keep terminations clear could result in property damage, severe personal injury, or death.

**! WARNING****Breathing Hazard - Carbon Monoxide Gas**

- Do not operate heater if flood damaged.
- Install vent system in accordance with local codes and manufacturers installation instructions.
- Do not obstruct heater air intake or exhaust. Support all vent piping per manufacturers installation instructions.
- Do not place chemical vapor emitting products near unit.
- According to NFPA 720, carbon monoxide detectors should be installed outside each sleeping area.
- Never operate the heater unless it is vented to the outdoors.
- Analyze the entire vent system to make sure that condensate will not become trapped in a section of vent pipe and therefore reduce the open cross sectional area of the vent.

**Breathing carbon monoxide can cause brain damage or death. Always read and understand instruction manual.**

LP-304

**! DANGER**

Due to the extreme flammability of most glues, cements, solvents, and primers used to join plastic exhaust vent and intake pipes, explosive solvent vapors must be cleared from all vent piping before start-up. Avoid using excess cement or primer, as this may pool in the vent pipes. Vent assemblies should be allowed to cure for a period of at least 8 hours before powering a connected appliance. Failure to follow these instructions will result in substantial property damage, severe personal injury, or death. It is the installers' responsibility to understand the hazards associated with explosive solvents and take the necessary precautions to avoid these risks.

**! WARNING**

- Only Stainless Steel exhaust vent pipe material may be insulated.
- DO NOT insulate the first three (3) linear feet of the exhaust vent run.
- DO NOT insulate PVC, CPVC, or Polypropylene exhaust vent pipe material. Doing so will cause increased vent wall temperatures, which could result in vent pipe failure.
- CPVC, Polypropylene, or Stainless Steel pipe material MUST be used if the first three (3) linear feet of the exhaust vent run passes through an enclosed space greater than 6" in length, such as a wall or ceiling.\*
- If CPVC is used to meet these requirements, the balance may be installed with approved PVC pipe.
- If Polypropylene or Stainless Steel is used to meet these requirements, the balance of the vent run MUST be installed with the same material.
- Failure to comply with these requirements could result in property damage, severe personal injury, or death.

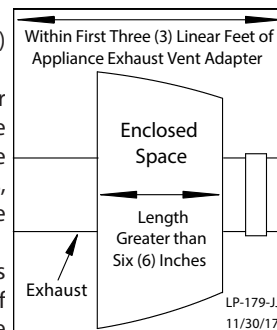

\*This rule applies when the exhaust vent passes through the enclosed space into another interior space, i.e. through a floor or wall from the mechanical room into another room. This rule DOES NOT apply when the exhaust vent passes through the enclosed space immediately to the exterior of the building.

## Part 5 - Venting

### B. Approved Materials for Exhaust Vent and Intake Pipe

Item	Material	Standards for Installation In:	
		United States	Canada
Pipe and Fittings Approved for Intake ONLY	ABS*	ANSI/ASTM D2661	ANSI/ASTM D2661
Pipe Approved for Intake OR Exhaust Vent	PVC Schedule 40/80	UL-1738 or ANSI/ASTM D1785	UL-1738 or ULC-S636
	PVC-DWV Schedule 40/80	UL-1738 or ANSI/ASTM D2665	
	CPVC Schedule 40/80	UL-1738 or ANSI/ASTM F441	
	Polypropylene	UL-1738 or ULC-S636	
	Stainless Steel AL29-4C	Certified for Category IV and Direct Vent Appliance Venting	
Pipe Fittings	PVC Schedule 40	UL-1738, ANSI/ASTM D2466 or D2665	UL-1738 or ULC-S636
	PVC Schedule 80	UL-1738, ANSI/ASTM D2467 or D2665	
	CPVC Schedule 40	UL-1738 or ANSI/ASTM F438	
	CPVC Schedule 80	UL-1738 or ANSI/ASTM F439	
Pipe Cement	ABS*	ANSI/ASTM D2235	IPEX System 636 Cements and Primers
	PVC	ANSI/ASTM D2564	
	CPVC	ANSI/ASTM F493	
Pipe Primer	PVC / CPVC	ASTM F656	

Table 11 - Approved Materials for Exhaust Vent and Intake Pipe

### DANGER

- The exhaust and intake components installed with this appliance must be used for near appliance piping BEFORE transitioning to the approved materials listed above. DO NOT REMOVE these installed components. Doing so WILL VOID appliance warranty.
  - In the US/Canada, PVC vent pipe and fittings SHALL NOT BE USED within the closet or alcove. Only approved CPVC, Polypropylene, or Stainless Steel vent pipe and fittings may be used.
  - PVC / CPVC pipe and fittings of the same diameter are considered interchangeable.
  - The use of cellular core PVC (ASTM F891), cellular core CPVC, or Radel® (polyphenolsulfone) in exhaust venting systems is prohibited.
  - Covering non-metallic vent pipe and fittings with thermal insulation is prohibited.
  - The boiler's vent and air intake connections are designed to accept 3" PVC/CPVC and Polypropylene directly. DO NOT insert PVC piping into the boiler's exhaust connection. When venting with PVC, insert the factory supplied 5" length of CPVC before transitioning to PVC.
  - When installing AL29-4C vent piping, install a PVC-to-stainless adapter at the boiler vent connection, and at the termination when using a PVC termination kit. DO NOT mix AL29-4C piping from different manufacturers unless using adapters specifically designed for the purpose by the manufacturer.
  - DO NOT mix components from different venting systems without proper adapters. The vent system could fail, causing leakage of flue products into the living space. Use only the approved pipe and fitting materials, and primer and cement specifically designed for the material used, as listed in the above table.
  - A double wall vent or insulated material may be used when using stainless steel vent material in a freezing climate.
  - \*ABS may be used for air intake applications ONLY.
  - Contact the venting material manufacturer if there is any question about the applicability of the proposed venting material.
- Failure to follow these directions will result in substantial property damage, severe personal injury, or death.

### CAUTION

High heat sources (generating heat 100°F / 37°C or greater, such as boiler flue pipes, space heaters, etc.) may damage plastic components of the boiler as well as plastic vent pipe materials. Such damages ARE NOT covered by warranty. It is recommended to keep a minimum clearance of 8" from high heat sources. Observe heat source manufacturer instructions, as well as local, state, provincial, and national codes, laws, regulations, and ordinances when installing this boiler and related components near high heat sources.

**NOTE:** The use of double-wall vent or insulated material for the combustion air intake pipe is recommended in cold climates to prevent the condensation of airborne moisture in the incoming combustion air.

### DANGER

You must not use "B" vent in an exhaust application. "B" vent is for intake applications ONLY. Using "B" vent in an exhaust application will result in serious injury or death.

### C. Additional Requirements for Installation in Canada

- Installations must be made with a vent pipe system certified to ULC-S636.
- The first three (3) feet of vent pipe from the boiler flue outlet must be readily accessible for visual inspection.
- The components of the certified vent system must not be interchanged with other vent systems or unlisted pipe / fittings.



D. Exhaust Vent and Intake Pipe Location

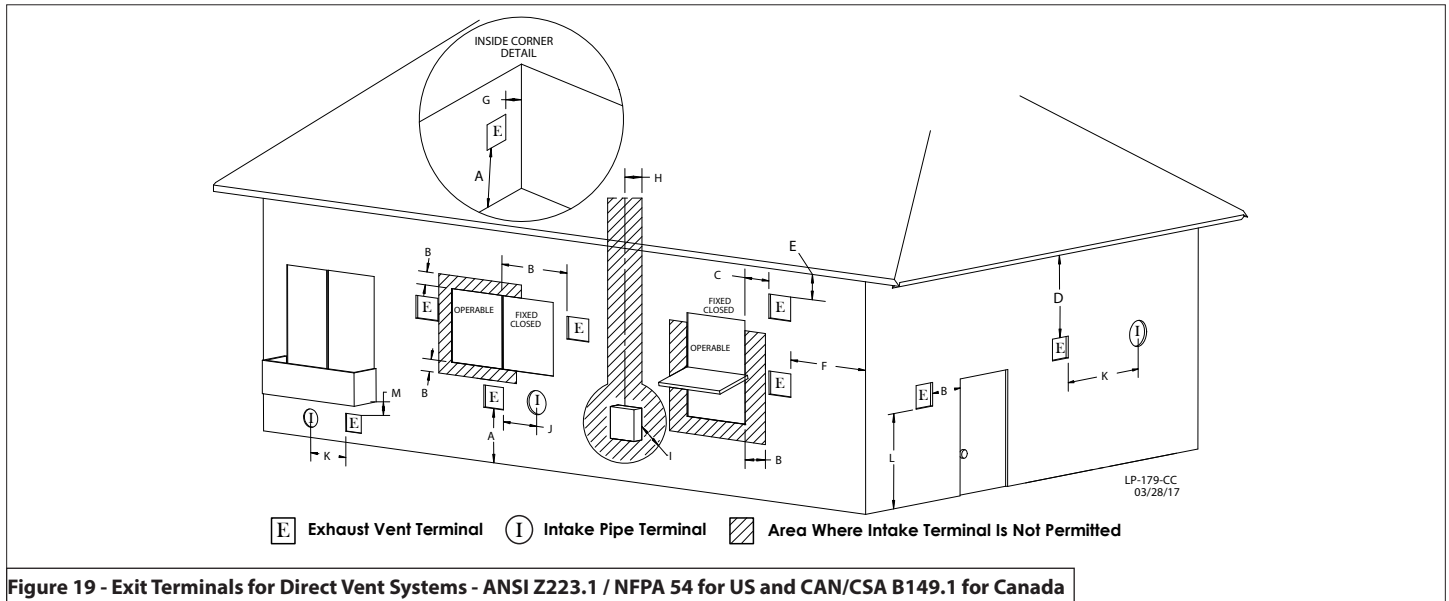

Figure 19 - Exit Terminals for Direct Vent Systems - ANSI Z223.1 / NFPA 54 for US and CAN/CSA B149.1 for Canada

DESCRIPTION		US	CANADA
<b>A</b>	Clearance above grade, veranda, porch, deck, or balcony	1 foot (30 cm)	
<b>B</b>	Clearance to window or door that may be opened	Direct Vent	1 foot
		Power Vent	4 ft below or to side of opening; 1 ft above opening
<b>C</b>	Clearance to permanently closed window	*	
<b>D</b>	Vertical clearance to ventilated soffit located above the terminal within a horizontal distance 2 feet (61 cm) from the center line of the terminal	*	
<b>E</b>	Clearance to unventilated soffit	*	
<b>F</b>	Clearance to outside corner	*	
<b>G</b>	Clearance to inside corner	*	
<b>H</b>	Clearance to each side of center line extended above meter / regulator assembly	*	
<b>I</b>	Clearance to service regulator vent outlet	*	Above a regulator within 3 feet (91 cm) horizontally of the vertical center line of the regulator vent outlet to a maximum vertical distance of 15 ft (4.5 m)
<b>J</b>	Clearance to nonmechanical air supply inlet to building or the combustion air inlet to any other appliance	Direct Vent	1 foot
		Power Vent	4 ft below or to side of opening; 1 ft above opening
<b>K</b>	Clearance to mechanical air supply inlet	3 feet above if within 10 feet horizontally	6 feet (1.83 m)
<b>L</b>	Clearance above paved sidewalk or paved driveway located on public property	Direct Vent	*
		Power Vent	7 feet (2.13 m)
<b>M</b>	Clearance under veranda, porch deck, or balcony	*	1 foot (30 cm)

Table 12 - Vent Termination Clearances - \*NOTE: For clearances not specified in ANSI Z223.1 / NFPA 54 for US and CAN/CSA B149.1 for Canada, please use clearances in accordance with local installation codes and the requirements of the gas supplier.

**! WARNING**

The building owner is responsible for keeping the exhaust and intake terminations free of snow, ice, or other potential blockages, as well as scheduling routing maintenance. Failure to keep the vent piping terminations clear and properly maintain the heater could result in property damage, severe personal injury, or death.

**! WARNING**

For each floor containing bedroom(s), a carbon monoxide detector and alarm shall be placed in the living area outside the bedrooms, as well as in the room that houses the heater. Detectors and alarms shall comply with NFPA 720 (latest edition). Failure to comply with these requirements could result in product damage, severe personal injury, or death.

## Part 5 - Venting

### E. Exhaust Vent and Intake Pipe Sizing

- All models ship with 3" diameter vent pipe exhaust vent and intake air pipe connections.
  - All 150 Models - Vent diameter may be DECREASED to 2".
  - 199 / 199C Models must be vented in 3" diameter pipe.
  - Increasing the vent diameter of ANY model boiler IS NOT an option.
- The total length of the intake air pipe run must not exceed **one hundred (100) feet in 2" pipe, or one hundred fifty (150) feet in 3" pipe.**  
**NOTE:** There is no minimum length for the intake air pipe run.
- The total length of the exhaust vent pipe run must not be less than six (6) feet.**
- The total length of the exhaust vent pipe run must not exceed one hundred (100) feet in 2" pipe, or one hundred fifty (150) feet in 3" pipe.**

Minimum - Maximum Vent Run Lengths		
Diameter	2"	3"
Intake Air Pipe Run	0 - 100 feet	0 - 150 feet
Exhaust Vent Run	6 - 100 feet	6 - 150 feet

Table 13 - Minimum - Maximum Vent Runs

- The equivalent length of elbows, tees, and other fittings are listed in the Friction Loss Table below.

Friction Loss Equivalent in Piping and Fittings	
Fittings or Piping	Equivalent Feet
	2" or 3"
90 Degree Elbow*	5'
45 Degree Elbow	3'
Coupling	0'
One Foot of Straight Pipe	1'
Concentric Kit	3'

Table 14 - \*Friction loss for long radius elbow is 1 foot less. **NOTE: Consult Polypropylene venting instructions for friction loss and pressure drop equivalents.**

#### Vent Sizing Example

If the exhaust vent run has two 90° elbows, 10 feet of straight pipe and a concentric kit we will calculate:

**Exhaust Vent Equivalent Length** = (2x5) + 10 + 3 = **23 feet** - Well below the maximum of 100 ft in 2" pipe, or 150 ft in 3" pipe.

If the intake air pipe run has one 90° elbow, two 45° elbows, and 14 feet of straight pipe:

**Intake Air Pipe Equivalent Length** = 5 + (2x3) + 14 = **25 feet** - Well below the maximum of 100 ft in 2" pipe, or 150 ft in 3" pipe.

**NOTE:** The intake air pipe and exhaust vent do not have to be of equal length. There is no balancing requirement between intake and exhaust.

### ! WARNING

Failure to install the boiler within the minimum and maximum vent length requirements could result in improper product operation and property damage, serious personal injury, or death.

### F. Tightening Boiler Collar to Exhaust Vent and Intake Pipe

Follow the steps to install exhaust vent pipe into the boiler vent collar. See Figure 20 for additional details.

**NOTE:** Clean and dry the boiler connection.

DO NOT use primer or cement on the boiler connection.

When preparing pipe for installation:

- Ensure cuts are square.
- Bevel cut edges by 1/16" - 1/8". Deburr the pipe.
- Lubricate the gasket.

- Push the length of pipe into the connection until it touches the bottom of the fitting.
- Tighten the clamps using a screwdriver.
- Ensure the pipe is secure before continuing installation.

**NOTE:** To install intake pipe, follow the steps for installing exhaust vent pipe.

### ! WARNING

When venting with PVC, first install the included 5" length of 3" CPVC into the boiler's exhaust connection, then adapt to PVC using approved CPVC to PVC transition cement. Installing PVC pipe into the boiler's exhaust connection is strictly prohibited - the strain of the gear clamp combined with heat can deform PVC over time and result in flue gas leakage causing property damage, severe personal injury, or death.

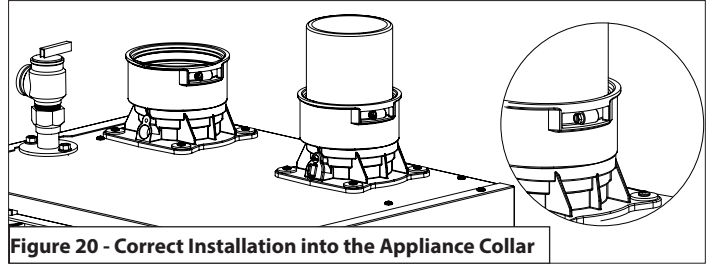

Figure 20 - Correct Installation into the Appliance Collar

#### Reducing Vent Diameter - 150 Models ONLY!

In order to use 2" pipe, it is required to reduce pipe size in a vertical length of pipe with a 3" x 2" reducing coupling (not included).

**NOTE:** A reducing coupling **MUST BE USED** when transitioning from 3" to 2" vent pipe. **DO NOT** use reducing bushings.

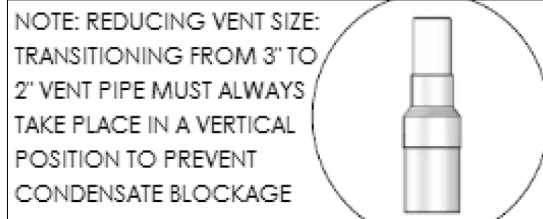

Figure 21 - Correct Installation into the Appliance Collar

### G. Exhaust Vent and Intake Pipe Installation

### ! WARNING

All joints of positive pressure vent systems must be sealed completely to prevent leakage of flue products into the living space. Failure to do so could result in property damage, serious injury, or death.

- Use only solid PVC, CPVC, or stainless steel pipe or a Polypropylene vent system approved for use with Category IV appliances. ABS pipe material may be used on air inlet piping **only**.
- Remove all burrs and debris from joints and fittings.
- When using PVC or CPVC pipe, all joints must be properly cleaned, primed, and cemented. Use only cement and primer approved for use with the pipe material. Cement must conform to ASTM D2564 for PVC and ASTM F493 for CPVC pipe. **NOTE: DO NOT CEMENT POLYPROPYLENE PIPE.**
- Ensure the vent is located where it will not be exposed to prevailing winds.
- In all roof venting applications, exhaust discharge must point away from the pitch of the roof.
- If the exhaust vent is to be terminated in a walled off area (such as a roof with a parapet wall), ensure the exhaust vent terminates a minimum of 10' from nearest wall and extends level with or above the top of the wall. This will ensure flue gas does not get trapped and possibly recirculated into the intake air pipe, which could contaminate the combustion air.

7. To prevent water leakage, install adequate roof flashing where the pipe enters the roof.
8. If it can be avoided do not locate vent directly over public walkways, driveways, or parking lots in climates where freezing conditions are possible. Condensate could drip and freeze, resulting in a slip hazard or damage to vehicles or machinery.
9. Due to potential moisture build-up, sidewall venting may not be the preferred venting option. To save time and cost, carefully consider venting installation and location.
10. Horizontal lengths of exhaust vent must slope back towards the boiler not less than ¼" per foot to allow condensate to drain from the vent pipe.
11. Do not terminate vent where vapors can accumulate and harm people or pets.
12. When it can be avoided, do not terminate vent where vapors can damage shrubs or plants. Such damages are not covered by product warranty.
13. Moisture in the exhaust gas will condense as it leaves the vent terminal. In cold weather this condensate can freeze on the exterior wall, under the eaves, and on surrounding objects, including shrubs. Some discoloration to the exterior of the building is to be expected. However, improper location or installation can result in severe damage to the structure or exterior finish of the building, and increase the opportunity for vent blockages and nuisance shutdowns.
14. In vacant chimney applications, install and seal a rain cap over existing chimney openings.
15. All piping must be fully supported. Use pipe hangers at a minimum of 4 foot intervals to prevent sagging of the pipe where condensate may form.
16. Do not use the boiler to support any piping.
17. Ensure the outdoor exhaust vent and intake pipe terminations are screened to prevent blockage caused by debris or birds. Vent screens are included with this boiler.
18. Maximum Snow Level Determination: These installation instructions reference snow levels in establishing a minimum height for the installation of exhaust vent or air intake terminations. Snow levels shall be determined as follows:
  - a. The installation location may, by ordinance, designate how snow levels are calculated in that location; or
  - b. In the absence of specific ordinances, snow levels shall be calculated from the average monthly maximum depth of snow accumulation as indicated by the National Weather Service's 10 year statistics for the installation location/geographical area.

In addition:

- Total length of vent piping shall not exceed the limits specified in this manual.
- The vent piping for this direct vented appliance is approved for zero clearance to combustible construction.
- The flue products coming from the exhaust vent will create a large plume when the heater is in operation. Avoid venting in areas that will affect neighboring buildings or be considered objectionable.
- DO NOT locate exhaust vent or intake pipe in a parking area where machinery may damage the pipe.
- DO NOT vent near soffit vents, crawl space vents, or other areas where condensate or vapor could create a nuisance or hazard or cause property damage.
- DO NOT vent where condensate vapor could cause damage or could be detrimental to the operation of regulators, relief valve, or other equipment.

**In the Commonwealth of Massachusetts and as Required by State and Local Codes:**

- The vented gas fueled appliance shall not be installed so its combustion, ventilation, or dilution air is obtained from a bedroom or bathroom.

- Signage: Whenever any through-the-wall (horizontal or sidewall) vent is installed less than seven feet above the finished grade, a metal or plastic identification plate shall be permanently mounted to the exterior of the building at a minimum height of eight feet above grade directly in line with the exhaust vent terminal. The sign shall read, in print no less than 0.5 inches in size, "GAS VENT DIRECTLY BELOW. KEEP CLEAR OF ALL OBSTRUCTIONS".
- Marking of Exhaust Vent and Intake Pipe: Piping used for ventilation, make-up, or combustion air intake shall be labeled as follows:
  - a. Throughout the entire developed length:
    - i. Labels must be placed every ten feet for exposed/visible piping; or
    - ii. Labels must be placed every three feet for concealed piping.
  - b. At all changes of direction;
  - c. On each side of a penetration through a partition, wall or ceiling; and
  - d. The labels shall be black lettering that:
    - i. Indicates that the piping is used for ventilation, make-up, or combustion air intake, and
    - ii. The letters shall be sized equal to a minimum of the pipe diameter. However, for piping with a diameter exceeding two inches, said lettering does not need to be larger than two inches.

The following table lists optional exhaust/intake terminations available from NTI:

Description	Stock Code
3" PVC Concentric Termination Kit	84634
3" PVC Low Profile Termination Kit	84357
2" PVC Low Profile Termination Kit	85062

**Table 15 - Optional Vent Kits**

## Part 5 - Venting

Description	Vent Size	Supplier Part Number	Figure	Vent Material Compatibility	Vent Option Availability	
					Roof	Wall
IPEX (or Equivalent) Low Profile (Wall) <sup>7</sup>	2"	196984 (NTI p/n 85062)	23, 27	PVC/CPVC	No	Yes
	3"	196985 (NTI p/n 84357)	23, 27			
IPEX (or Equivalent) Concentric (Wall/Roof) <sup>4, 5, 6, 7</sup>	2"	196125	24, 28, 35, 39			
	3"	196116 (NTI p/n 84634)	24, 28, 35, 39			
		196117	24, 28, 35, 39			
DuraVent Polypro® Concentric (Wall)	2 - 3"	2PPS-HK, 3PPS-HK	25, 29		Polypro® Polypropylene	No
DuraVent Polypro® Concentric (Roof)	2 - 3"	2PPS-VK, 3PPS-VK	36, 40	Yes		No
InnoFlue® Flush Mount (Wall)	2 - 3"	ISLPT0202, ISLPT0303	23, 27	InnoFlue® Polypropylene	No	Yes
InnoFlue® Concentric (Wall)	2 - 3"	ICRT2439, ICTC0224	25, 29		No	Yes
InnoFlue® Concentric (Roof)	2 - 3"	ICRT3539, ICTC0335	36, 40		Yes	No
Z-DENS® Concentric (Wall)	2 - 3"	2ZDHK2, 2ZDHK3	Not Shown	Z-DENS® Polypropylene	No	Yes
Z-DENS® Concentric (Roof)	2 - 3"	2ZDVK2, DZDVK3	Not Shown		Yes	No

### NOTES:

- 1 Instructions included with termination kits contain detailed assembly and installation instructions.
- 2 Clearance requirements in this manual supersede those of the instructions included with the vent terminal.
- 3 Piping **MUST** be secured to the vent terminal during installation.
- 4 IPEX Concentric Terminal **MUST** be cemented together and to the vent pipes during installation.
- 5 Vent Screens provided with boiler may be used with the IPEX Concentric Vent Kits; otherwise use IPEX vent screens (2 in. vent screen p/n 196050; 3 in. vent screen p/n 196051 - each sold separately).
- 6 IPEX Low Profile and Concentric kits (excluding p/n 197117) are constructed out of ULC-S636 approved PVC. Check with your local authority for the acceptance of PVC as a venting material prior to use.
- 7 IPEX Concentric kits can be shortened to fit the requirements of the installation. See instructions included with the kit for more details.

**Table 16 - Optional Vent Termination Kits**

## H. Applications

### 1. Direct Vent Installation of Exhaust and Intake

If installing a direct vent option, combustion air must be drawn from the outdoors directly into the boiler intake, and exhaust must terminate outside. There are three basic direct vent options detailed in this manual:

1. Side Wall Venting,
2. Roof Venting, and
3. Unbalanced Venting.

Be sure to locate the boiler such that the exhaust vent and intake pipe can be routed through the building and properly terminated. Different vent terminals can be used to simplify and eliminate multiple penetrations in the building structure (see Optional Equipment in Venting Section). The exhaust vent and intake pipe lengths, routing and termination methods must all comply with the methods and limits given in the Venting section of this manual.

When installing a combustion air intake from outdoors, care must be taken to utilize uncontaminated combustion air.

**NOTE:** To prevent combustion air contamination, see Table 6.

### WARNING

All vent pipes must be glued, properly supported, and the exhaust pitched a minimum of 1/4" per foot back to the boiler to allow drainage of condensate. When placing support brackets on vent piping, the first bracket must be within 1 foot of the boiler and the balance of 4 foot intervals on the vent pipe. Venting must be readily accessible for visual inspection from the first three feet from the boiler.

Take extra precaution to adequately support the weight of vent pipes terminating through the roof. Failure to properly support roof terminated piping could result in property damage, serious injury, or death.

## Part 5 - Venting

### Sidewall Venting Options - Direct Vent Installation

#### Two Pipe Termination

#### ! WARNING

Exhaust must terminate a minimum of 18" above the air intake termination. See Figure 26 for more details.

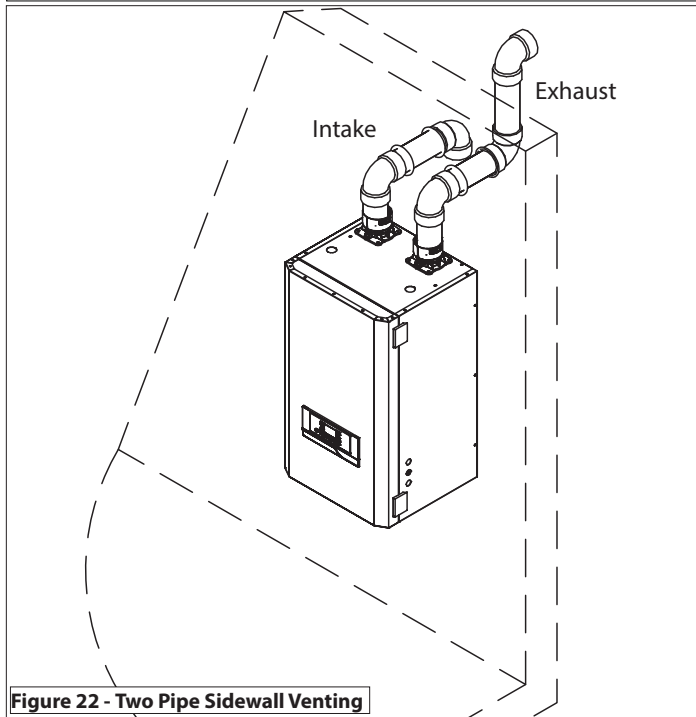

Figure 22 - Two Pipe Sidewall Venting

#### Concentric Termination

#### ! WARNING

3" IPEX Concentric Termination illustrated. See Figure 28 for more details.

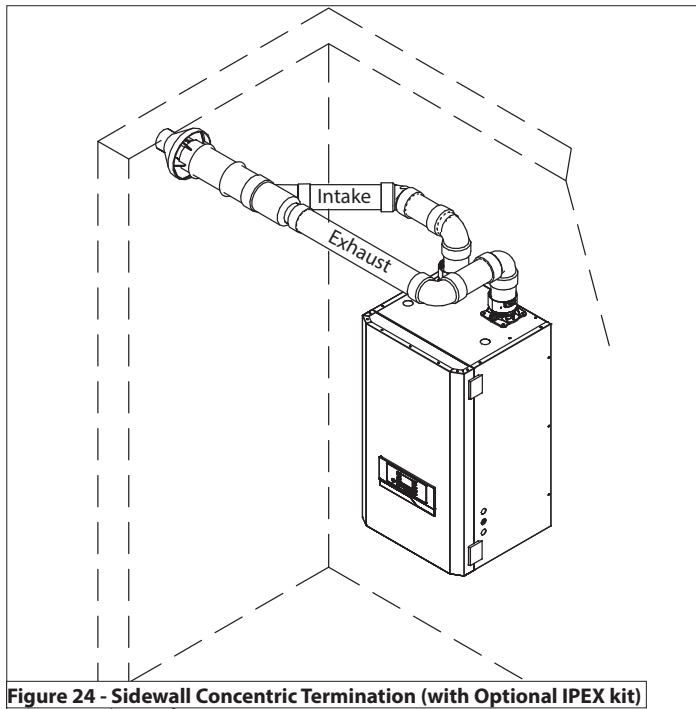

Figure 24 - Sidewall Concentric Termination (with Optional IPEX kit)

**NOTE:** These drawings are meant to demonstrate system venting only. The installer is responsible for all equipment and detailing required by local codes.

#### Low Profile Termination

#### ! WARNING

Exhaust must terminate a minimum of 18" above the air intake termination. See Figure 27 for more details.

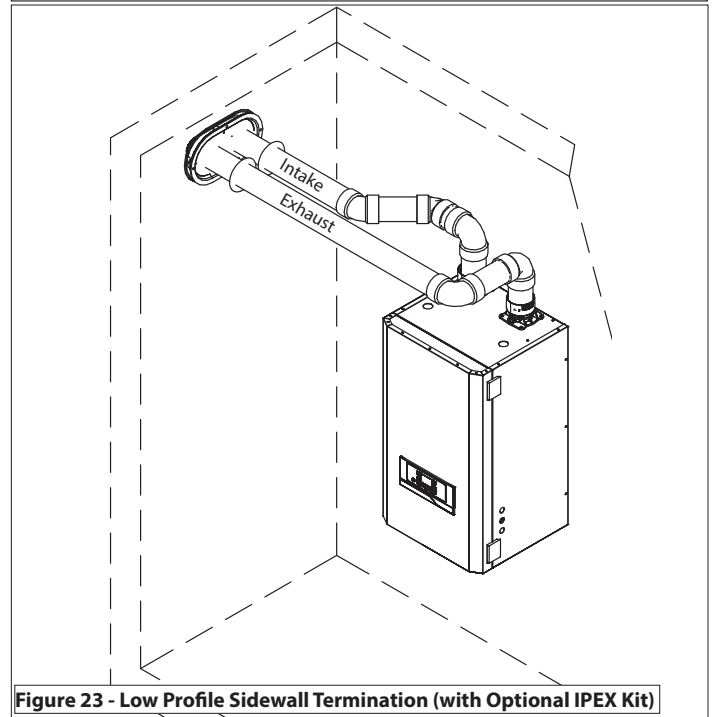

Figure 23 - Low Profile Sidewall Termination (with Optional IPEX Kit)

#### ! WARNING

3" Duravent / Innoflue Concentric Termination illustrated. See Figure 29 for more details.

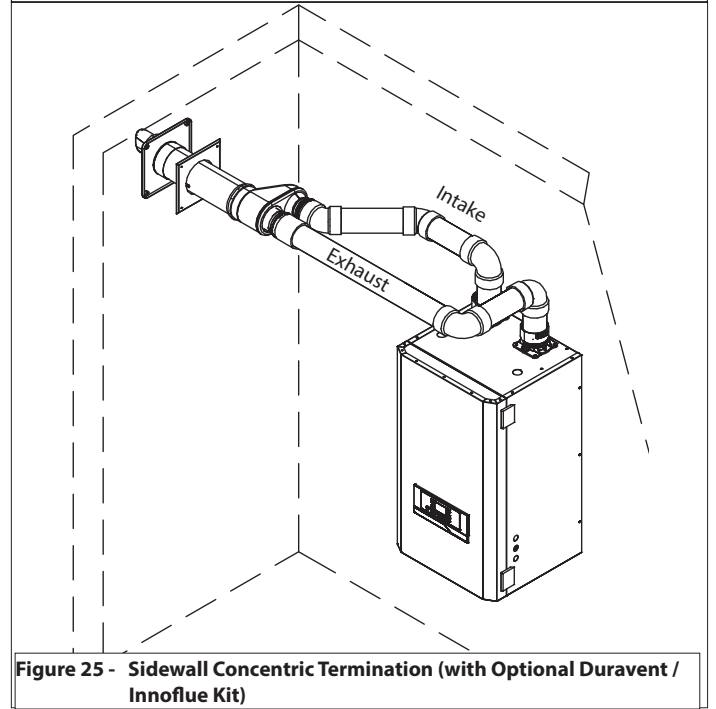

Figure 25 - Sidewall Concentric Termination (with Optional Duravent / Innoflue Kit)



Sidewall Venting Options - Direct Vent Installation

Two Pipe Termination

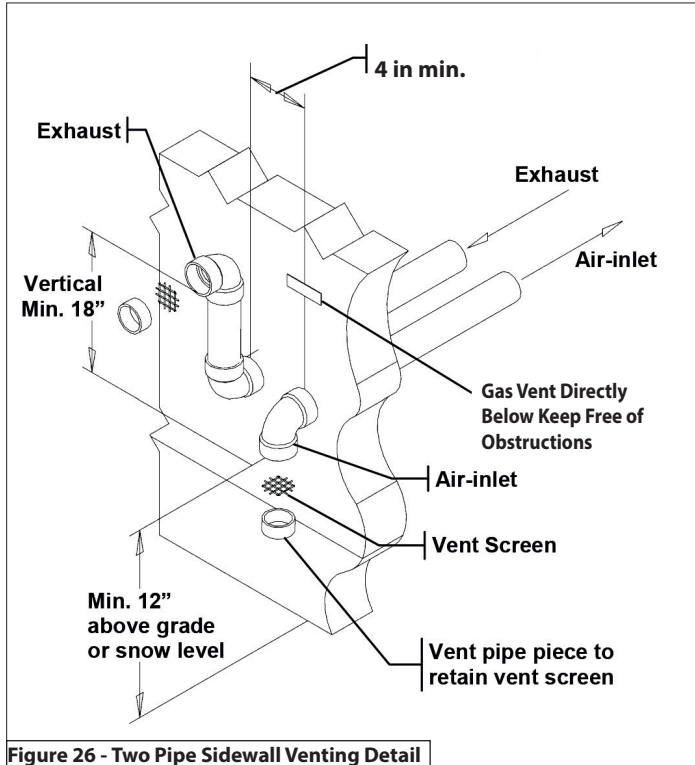

Figure 26 - Two Pipe Sidewall Venting Detail

Low Profile Termination

**! WARNING**

Refer to documentation included with termination kit for complete installation instructions.

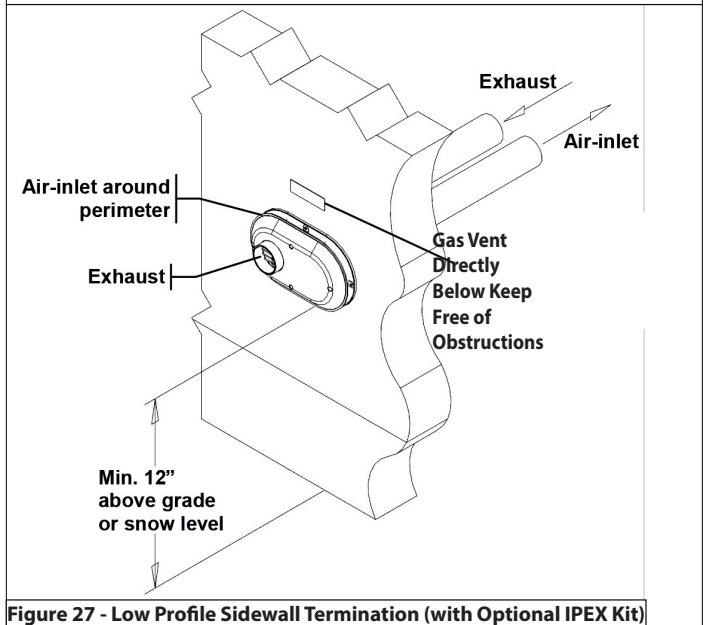

Figure 27 - Low Profile Sidewall Termination (with Optional IPEX Kit)

Concentric Termination

**! WARNING**

Refer to documentation included with termination kit for complete installation instructions.

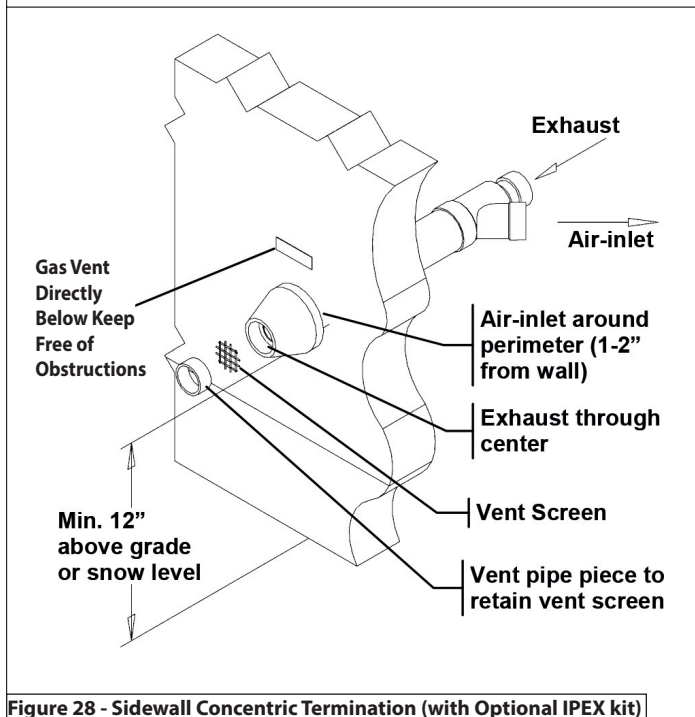

Figure 28 - Sidewall Concentric Termination (with Optional IPEX kit)

**! WARNING**

Refer to documentation included with termination kit for complete installation instructions.

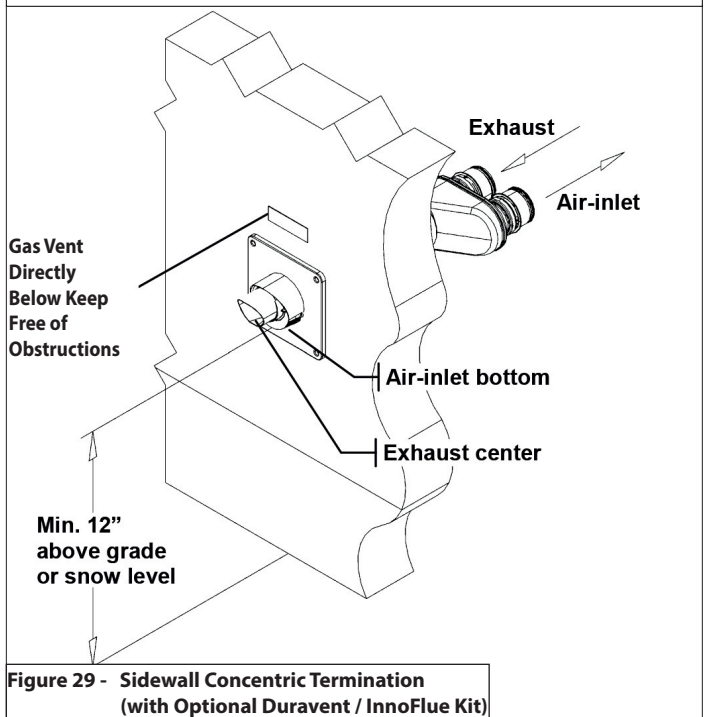

Figure 29 - Sidewall Concentric Termination (with Optional Duravent / InnoFlue Kit)

**NOTE:** These drawings are meant to demonstrate system venting only. The installer is responsible for all equipment and detailing required by local codes.

## Part 5 - Venting

### Snorkel Venting (Two Pipe Sidewall Venting Terminations Beneath an Overhang)

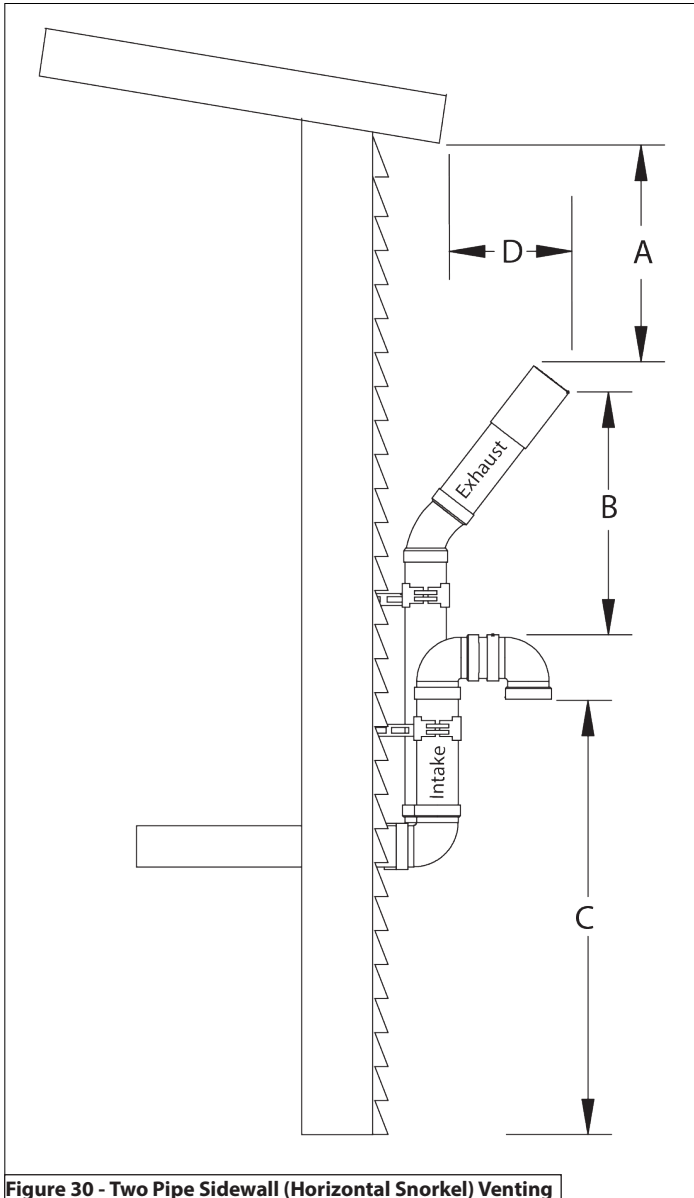

Figure 30 - Two Pipe Sidewall (Horizontal Snorkel) Venting

#### NOTES:

- For every 1" of overhang, the exhaust vent must be located 1" vertical below the overhang (12" minimum). Overhang means top of building structure (roof) and not two adjacent walls (corner of building).
- Maintain minimum separation between exhaust vent and air intake sidewall terminations, as required by local codes.
- Maintain 12" minimum clearance above highest anticipated snow level or grade (whichever is greater).
- The exhaust vent must extend a minimum of 12" to a maximum of 24" beyond the building.

**NOTE:** These drawings are meant to demonstrate system venting only. The installer is responsible for all equipment and detailing required by local codes.

### Venting Below Grade

For installations that exit the wall below grade:

- Excavate the site to a point where the pipes are to exit as shown in Figure 31.
- Ensure the wall is fully sealed where the pipes penetrate.
- The exhaust vent / air intake piping **MUST** be secured to the side of the building above grade, as shown, to provide rigidity.
- Ensure that the exhaust vent / air intake clearances are maintained.

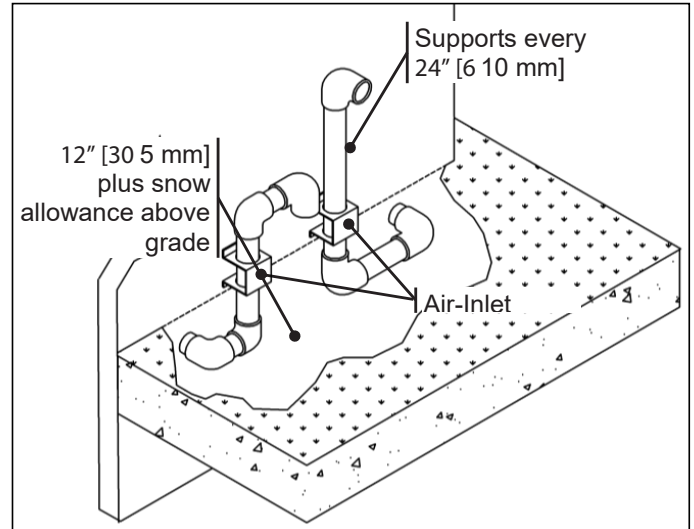

Figure 31 - Venting Below Grade

### Outdoor Venting

Vent piping outside the building is permitted under the following conditions:

- The maximum length outside the building is 20 feet (6.1 m). Note that outdoor length must be included in the overall vent length calculation.
- All normal termination clearances are maintained.
- The pipe is supported every 24" (610 mm).
- The exhaust and air intake are sloped back to the boiler 1/2" elevation for every linear foot (13 mm for every linear 305 mm).

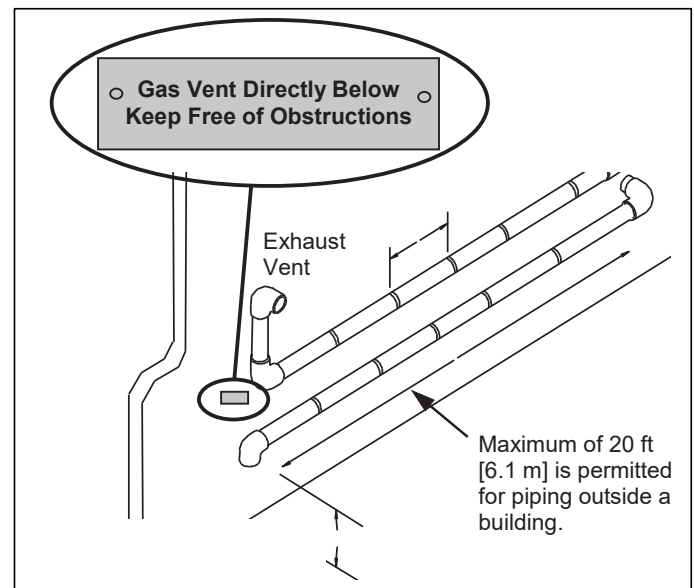

Figure 32 - Outdoor Venting

Roof Venting Options - Direct Vent Installation

Two Pipe Termination

**! WARNING**

Exhaust must terminate a minimum of 18" above the air intake termination. See Figure 37 for more details.

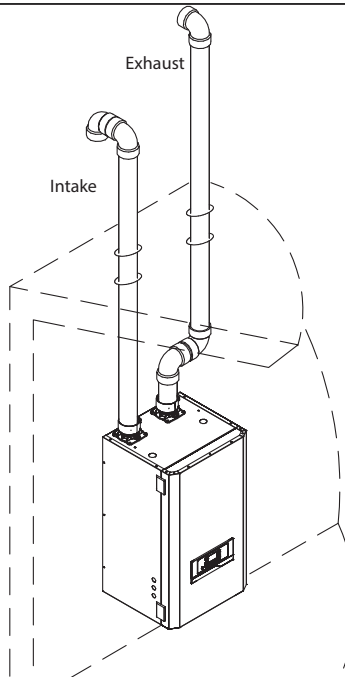

Figure 33 - Two Pipe Roof Venting

Unbalanced Termination (Roof Exhaust / Sidewall Intake)

**! WARNING**

Exhaust must terminate a minimum of 12" above snow level. See Figure 38 for more details.

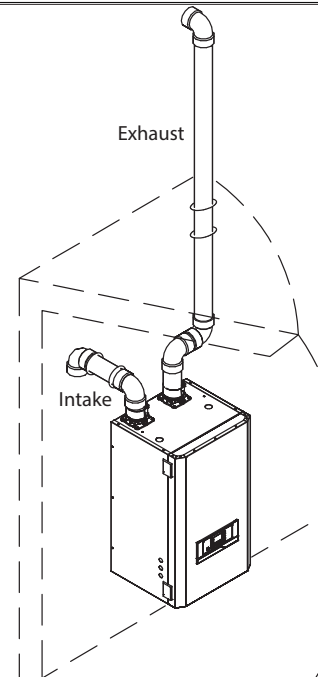

Figure 34 - Unbalanced Venting - Roof Exhaust and Sidewall Intake

Concentric Termination

**! WARNING**

3" IPEX Concentric Termination illustrated. See Figure 39 for more details.

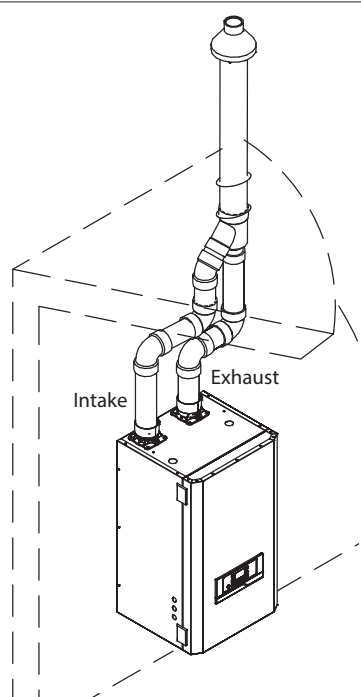

Figure 35 - Roof Concentric Termination (with Optional IPEX kit)

**! WARNING**

3" Polypro / InnoFlue Concentric Termination illustrated. See Figure 40 for more details.

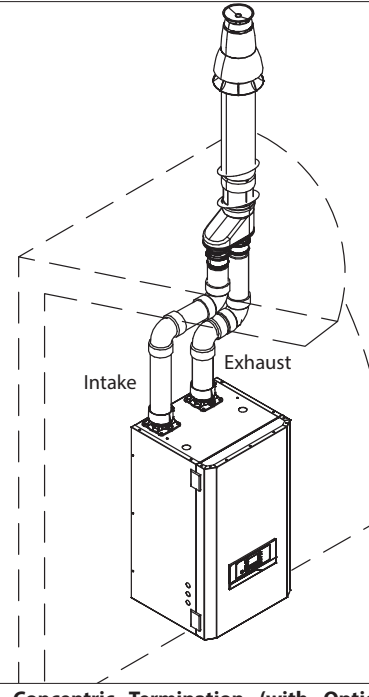

Figure 36 - Roof Concentric Termination (with Optional Duravent / InnoFlue Kit)

**NOTE:** These drawings are meant to demonstrate system venting only. The installer is responsible for all equipment and detailing required by local codes.

## Part 5 - Venting

### Roof Venting Options - Direct Vent Installation

#### Two Pipe Termination

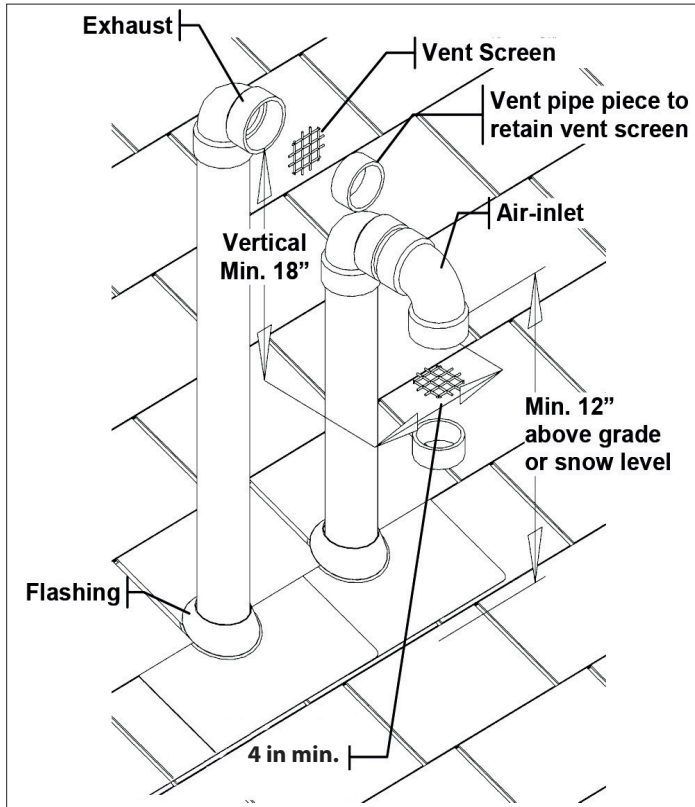

Figure 37 - Two Pipe Roof Venting Detail

### Unbalanced Venting - Roof Exhaust Termination

#### ! WARNING

Figure illustrates two options for exhaust termination only. Neither vent pipe illustrated is intended for combustion air intake.

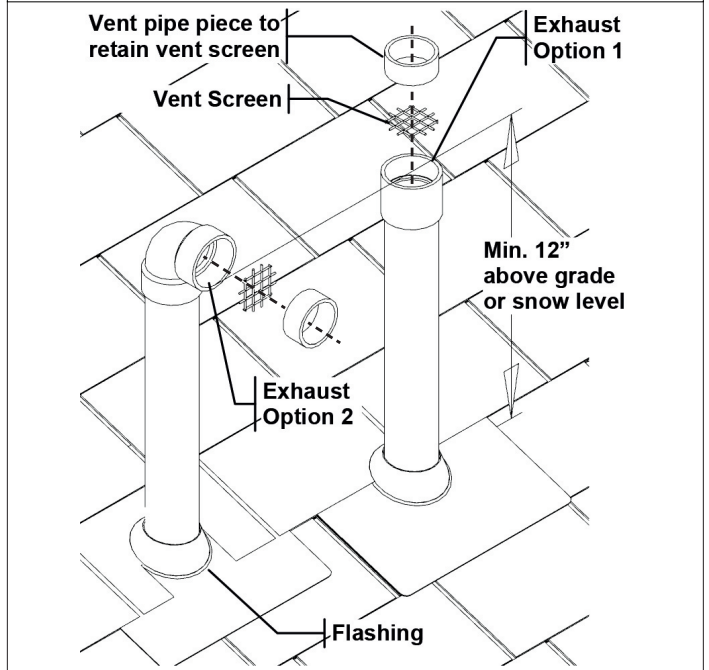

Figure 38 - Unbalanced Venting - Roof Exhaust Termination Options

#### Concentric Termination

#### ! WARNING

Refer to documentation included with termination kit for complete installation instructions.

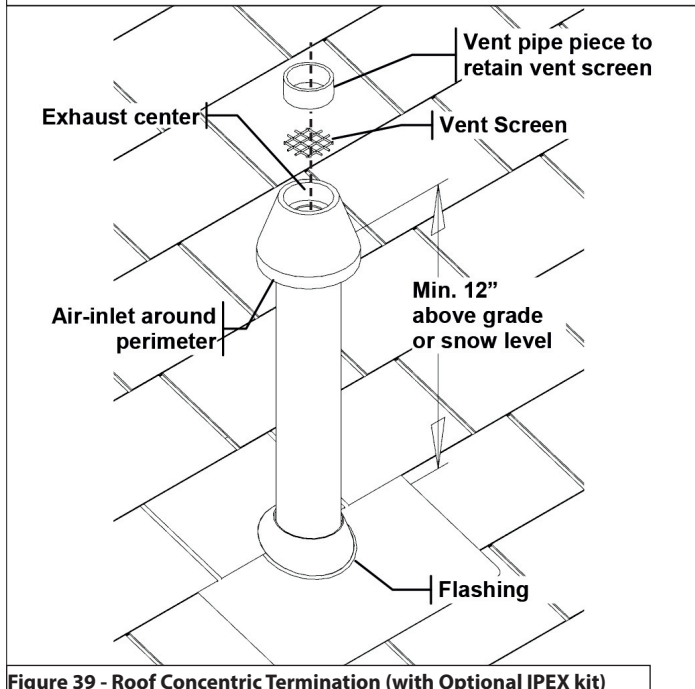

Figure 39 - Roof Concentric Termination (with Optional IPEX kit)

#### ! WARNING

Refer to documentation included with termination kit for complete installation instructions.

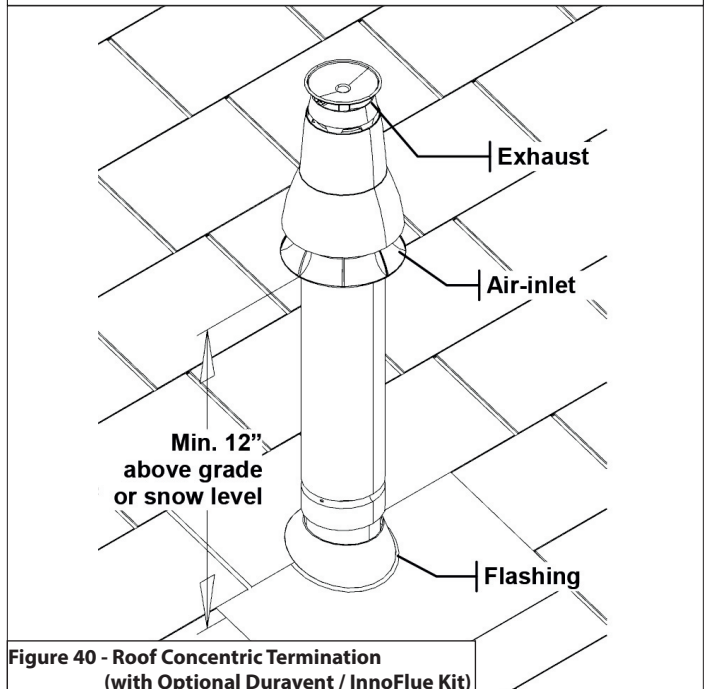

Figure 40 - Roof Concentric Termination (with Optional Duravent / InnoFlue Kit)

**NOTE:** These drawings are meant to demonstrate system venting only. The installer is responsible for all equipment and detailing required by local codes.

**2. Venting Through an Existing System**

This boiler may be vented through an existing unused vent system. The inner diameter of the existing vent system is utilized for the combustion air source. Two methods have been approved for such venting: Concentric Venting Through an Existing System and Venting as a Chase.

Vent / Air Inlet Size	Minimum Existing Vent / Chase Size
2"	4"
3"	5"

Table 17 - Minimum Existing Vent / Chase Sizing

**! DANGER**

Do not install the boiler into a common existing vent with any other appliance. This will cause flue gas spillage or boiler malfunction, resulting in substantial property damage, serious personal injury, or death.

The upper and lower vent terminations as well as all joints in the venting system must be properly sealed to ensure that all combustion air is drawn properly and exhaust does not leak from the system. Failure to properly seal the venting system will result in property damage, serious personal injury, or death.

**CAUTION**

Contractors must check state and local codes before installing through an existing vent opening. State and local codes always take precedence over manufacturer's instructions. Failure to check state and local codes before installing through an existing opening could result in property damage and add significantly to installation costs.

If an existing venting system is converted for use with this boiler, the installer must ensure that the existing venting system is clean and free from particulate contamination that could damage the boiler. Failure to do so could result in property damage and boiler failure. Such failure IS NOT covered under warranty.

**Concentric Venting Through an Existing System**

NOTE: The following instructions refer only to venting through an existing vent system, and not to venting with NTI's optional concentric vent kits. Refer to Concentric Vent Kit installation manual (LP-166) for further information on venting with the optional concentric vent kits. Concentric venting through an existing system must run vertically through the roof. See Table 17 for proper minimum vent sizing. Use only the approved venting materials specified in Table 11 for piping the system. All instructions listed in this Venting section apply. See Figures 41-1 and 41-2 for venting demonstrations.

**Chase Venting Through an Existing System**

When venting as a chase, follow all instructions included in this Venting section, including those in the previous Concentric Venting Through an Existing System section. See Figure 41-3 for chase venting demonstration.

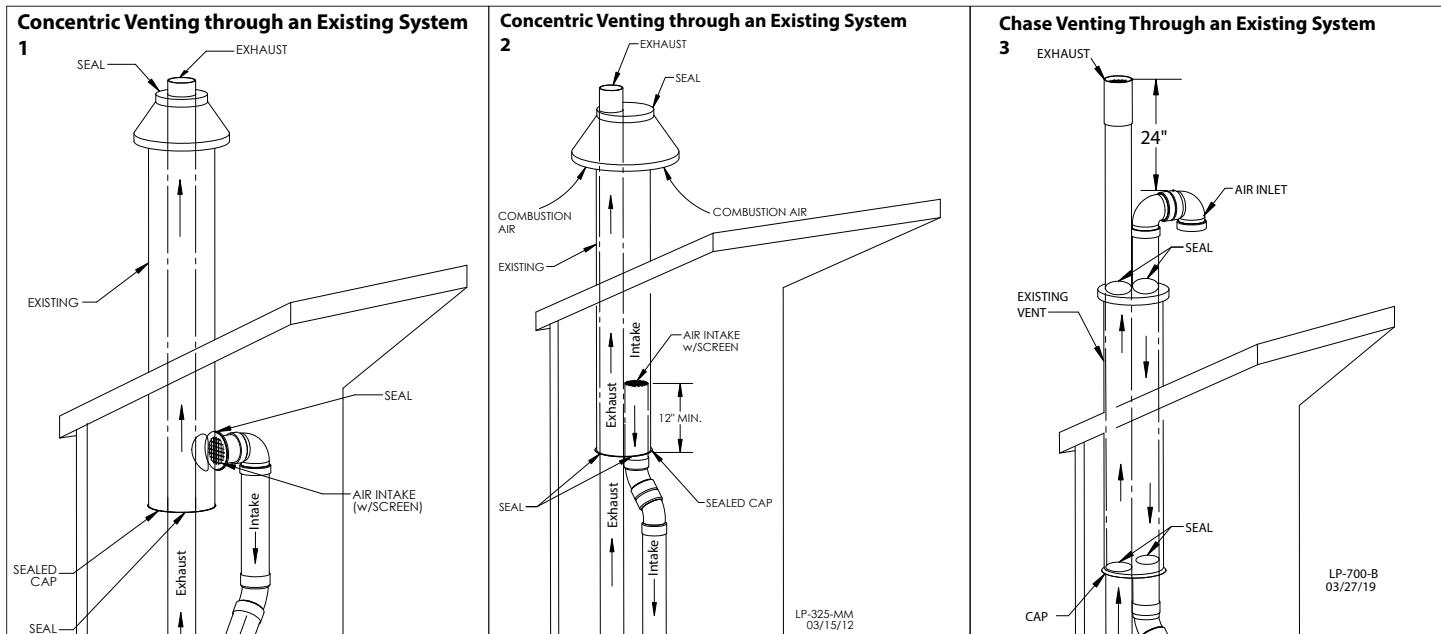

Figure 41 - 1, 2 - Concentric Venting Through an Existing System, 3, Chase Venting Through an Existing System

NOTE: These drawings are meant to demonstrate system venting only. The installer is responsible for all equipment and detailing required by local codes.



## Part 5 - Venting

### 3. Power Venting, Indoor Combustion Air in Confined or Unconfined Space

This boiler requires fresh, uncontaminated air for safe operation and must be installed in a mechanical room where there is adequate combustion and ventilating air. **NOTE: To prevent combustion air contamination, see Table 6.**

When the installation uses Indoor Combustion Air, provisions for combustion and ventilation air, in accordance with section "Air for Combustion and Ventilation," of the National Fuel Gas Code, ANSI Z223.1/NFPA 54 (USA), or Clause 8.2, 8.3 or 8.4 of the Natural Gas and Propane Installation Code, CAN/CSA B149.1 (Canada), or applicable provisions of the local building codes, must be adhered to.

Combustion air from the indoor space can be used if the space has adequate area or when air is provided through a duct or louver to supply sufficient combustion air based on the boiler input. **Never obstruct the supply of combustion air to the boiler.** If the boiler is installed in areas where indoor air is contaminated (see Figure 42) it is imperative that the boiler be installed as direct vent so that all combustion air is taken directly from the outdoors into the boiler intake connection.

**Unconfined space** is space with volume greater than 50 cubic feet per 1,000 Btu/hour (4.8 cubic meters per kW) of the total input rating of all fuel-burning appliances installed in that space. Rooms connected directly to this space, through openings not furnished with doors, are considered part of the space.

**Confined space** is space with volume less than 50 cubic feet per 1,000 Btu/hour (4.8 cubic meters per kW) of the total input rating of all fuel-burning appliances installed in that space. Rooms connected directly to this space, through openings not furnished with doors, are considered part of the space.

When drawing combustion air from inside a conventionally constructed building to a confined space, such space should be provided with two permanent openings: one located 6" (15 cm) below the space ceiling, the other 6" (15cm) above the space floor. Each opening should have a free area of one square inch per 1,000 Btu/hr (22cm<sup>2</sup>/kW) of the total input of all appliances in the space, but not less than 100 square inches (645cm<sup>2</sup>).

If the confined space is within a building of tight construction, air for combustion must be obtained from the outdoors as outlined in the Venting section of this manual. See Figure 43.

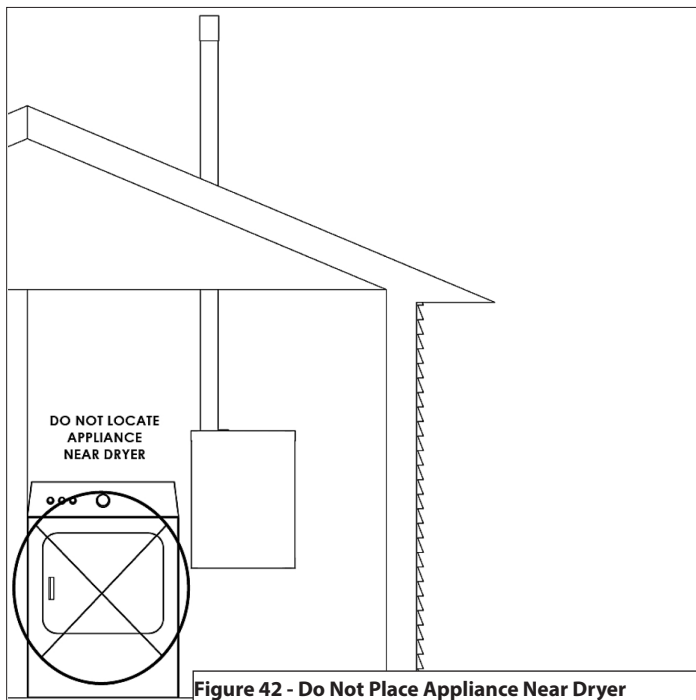

Figure 42 - Do Not Place Appliance Near Dryer

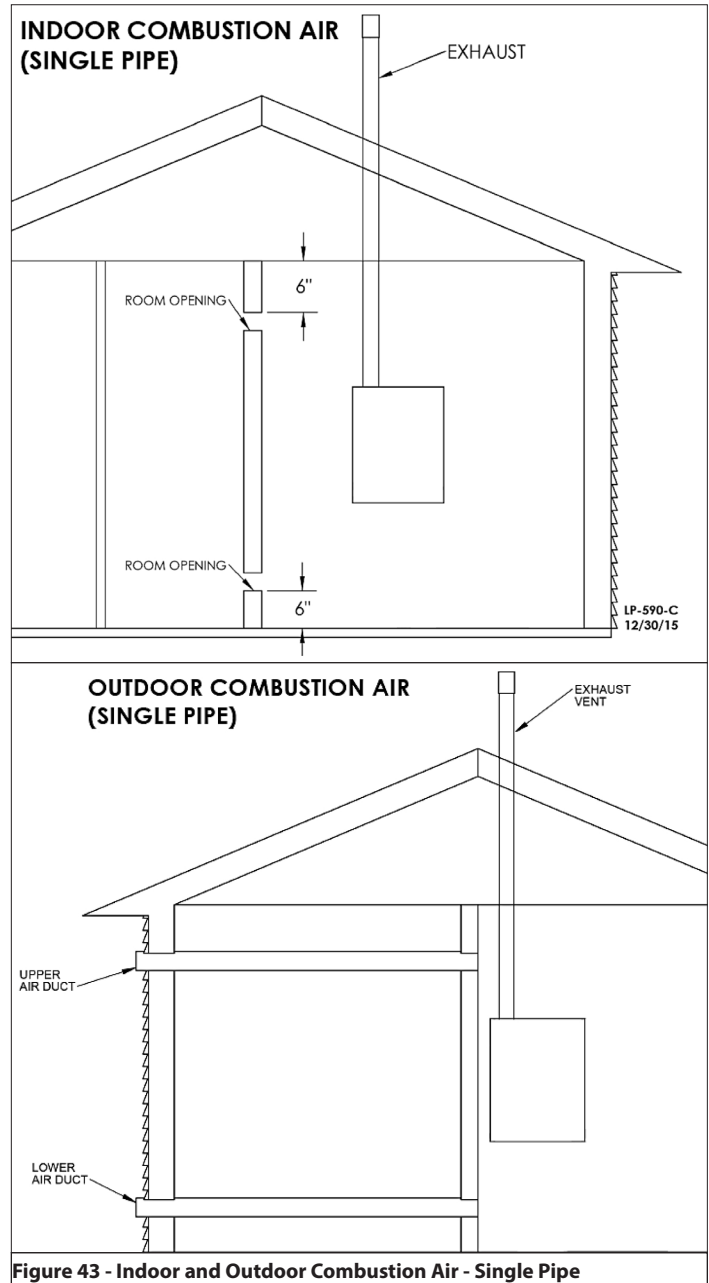

Figure 43 - Indoor and Outdoor Combustion Air - Single Pipe

**WARNING**

Breathing Hazard - Carbon Monoxide Gas

- Do not operate heater if flood damaged.
- Install vent system in accordance with local codes and manufacturers installation instructions.
- Do not obstruct heater air intake or exhaust. Support all vent piping per manufacturers installation instructions.
- Do not place chemical vapor emitting products near unit.
- According to NFPA 720, carbon monoxide detectors should be installed outside each sleeping area.
- Never operate the heater unless it is vented to the outdoors.
- Analyze the entire vent system to make sure that condensate will not become trapped in a section of vent pipe and therefore reduce the open cross sectional area of the vent.

Breathing carbon monoxide can cause brain damage or death. Always read and understand instruction manual.

LP-304



## CAUTION

This condensing high efficiency boiler has a condensate removal system. Condensate is water vapor derived from combustion products, similar to that produced by an automobile when it is initially started. It is very important that the condensate line is sloped down away from the boiler and to a suitable drain.

The condensate line must remain unobstructed. If allowed to freeze in the line or obstructed in any other manner, condensate can exit from the boiler tee, resulting in potential water damage to property.

When installing a condensate pump, select one approved for use with condensing boilers and furnaces. The condensate pump should have an overflow switch to prevent property damage from spillage.

Condensate from the boiler will be slightly acidic (pH from 2 to 4.5). Check with your local gas company to determine if combustion condensate disposal is permitted in your area. Install a neutralizing filter if required by local codes.

### NOTES:

1. Due to its efficient design, the boiler produces condensate (water) as a normal by-product. This condensate is acidic, with a pH level between 2 and 4.5. This condensate must be drained away from the boiler and disposed in accordance with all local regulations.
2. The condensate line should be as short as possible and must be pitched at least 1/4" per foot to properly drain. If this cannot be done, increase the condensate line to a minimum of 1" ID and place a tee in the line to properly reduce vacuum lock in the drain line. Tees should be placed after the condensate neutralizer (if used).
3. Use corrosion-resistant materials to drain condensate. Use the included flexible plastic hose and flexible tube, PVC, or CPVC pipe. PVC or CPVC pipe must comply with ASTM D1785, F441, or D2665. Cement must comply with ASTM D2564 for PVC pipe or F493 for CPVC pipe. For Canadian applications, use CSA or ULC certified flexible tube, PVC or CPVC pipe, fittings, and cement.
4. If using flexible tube, place an overflow tee in the tube line to prevent

condensate backing up into the boiler if the tube should kink. Ensure the overflow tee is positioned near a drain or in a location that will not damage the surrounding area.

5. Do not reduce the size of the condensate line. The line must at minimum equal the diameter of the line included with the appliance.

6. A frozen condensate line could result in a blocked vent condition. It is very important to protect the condensate line from freezing temperatures or any type of blockage. In installations that may encounter sustained freezing conditions, the use of heat tape is recommended to avoid freezing of the condensate line. Longer condensate runs are more prone to freezing.

7. Support of the condensate line may be necessary to avoid blockage of the condensate flow.

8. Local building codes may require an in-line neutralizer to be installed (not included) to treat the condensate. See Figure 45. If required by local authorities, a condensate filter of lime crystals, marble, or phosphate chips will neutralize slightly acidic condensate. Follow all the installation instructions included with the neutralizer. If a neutralizer is installed, periodic replacement of the limestone (or neutralizing agent) will be required. The rate of depletion of the limestone varies with usage of the boiler. During the first year of boiler operation, check the neutralizer every few months for depletion.

9. Route the drain line to a nearby floor drain, laundry tub, or condensate pump. If the boiler condensate outlet is lower than the drain, you must use a condensate removal pump.

**NOTE:** If a nearby laundry tub is used as a disposal for waste water from the washing machine, draining the condensate into this tub allows the soapy water discharge to neutralize the acidic condensate.

10. An error will appear on the boiler display if condensate line is blocked. The boiler will not operate with a blocked condensate line. It is extremely important to have this condition repaired by a qualified service technician.

11. Damages due to frozen or blocked condensate lines or leaks ARE NOT covered by warranty.

**NOTE:** To clean out condensate trap, see Maintenance section.

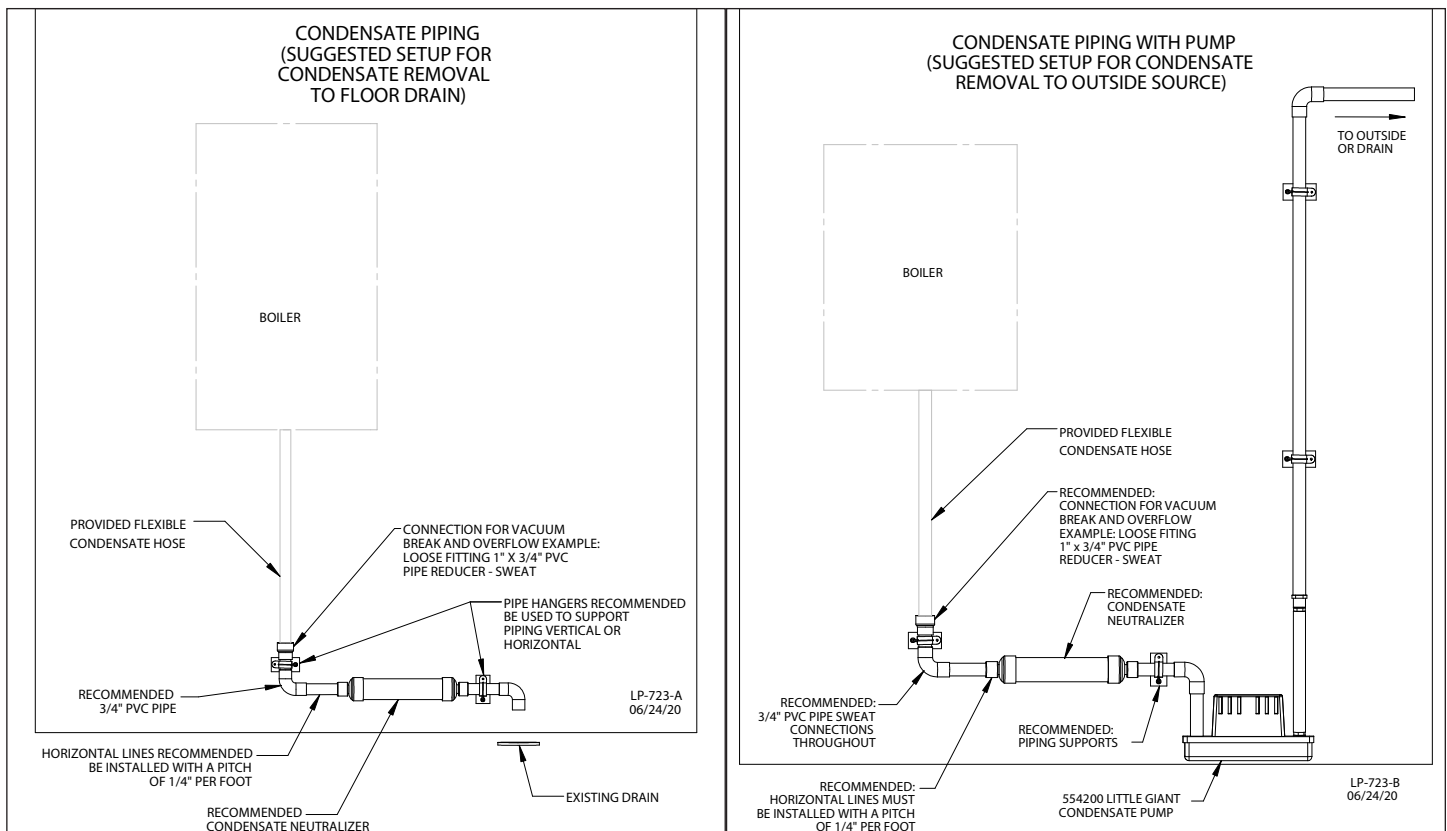

Figure 44 - Condensate Piping Suggestions

**! WARNING**

Install wiring and electrically ground boiler in accordance with the authority having jurisdiction or, in the absence of such an authority, follow the National Electrical Code, NFPA 70, and/or CSA C22.1 Electrical Code-Part 1 in Canada. Failure to follow all applicable local, state, and national regulations, mandates, and building supply codes for guidelines to install the electrical power supply could result in property damage, serious personal injury, or death.

**ELECTRICAL SHOCK HAZARD** - To ensure safety, turn off electrical power supply at service entrance panel before making any electrical connections to avoid possible electric shock hazard. Failure to do so could result in property damage, serious personal injury, or death.

Jumping out control circuits or components **WILL VOID** product warranty and can result in property damage, personal injury, or death.

It is of extreme importance that this unit be properly grounded. It is very important that the building system ground is inspected by a qualified electrician prior to making this connection. Electrical power must only be turned on when the boiler is completely filled with cold water. Failure to follow these instructions could result in component or product failure, serious injury, or death.

**CAUTION**

Label all wires prior to disconnecting when servicing the boiler. Wiring errors can cause improper and dangerous operation. Failure to follow these instructions may result in property damage or personal injury.

**A. Wiring**

The boiler is equipped with a three prong power cord. The boiler is limited to a maximum of 15 amps at 120 volts in use.

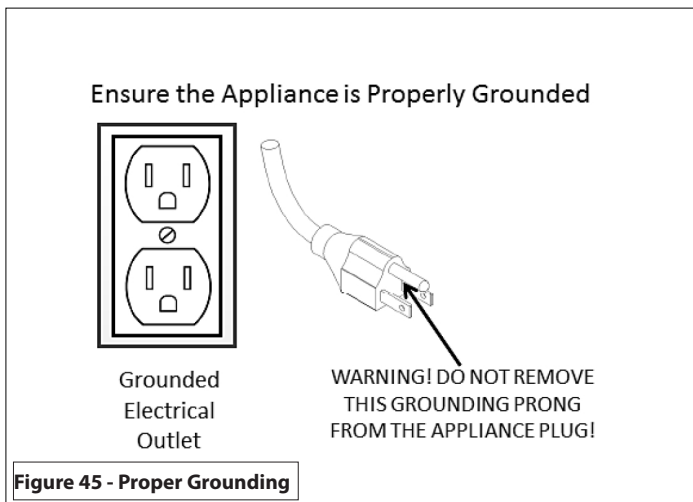

1. This boiler must be properly grounded. Ensure the electrical receptacle is properly grounded. Do not remove the grounding prong from the boiler plug.
2. Do not attach the ground wire to either the gas or water piping.
3. The wiring diagrams in this manual are to be used for reference purposes only.
4. Refer to these diagrams and the wiring diagrams of any external controls used with the installation when wiring the boiler. Read, understand, and follow all wiring instructions supplied with the controls.
5. Do not disconnect the power supply when the boiler is in normal operation.

**NOTE:** For additional electrical protection, the use of a whole house surge protector is recommended. Damage caused by power surges IS NOT covered by the warranty.

**1. Connecting Power (120V) for DHW and CH Circulators**

To connect power for the CH and DHW external pump at the boiler junction box:

1. Shut off the power supply at the boiler and at the circuit breaker.
2. Shut off the gas at the manual shutoff.
3. Remove the boiler front cover.
4. Disconnect the three clips and open the junction box
5. Insert the circulator power cable through the hole in the side panel; use an appropriate strain relief/conduit hub to secure the cable to the side panel.
6. Connect the cable on the connector CN5 (CH pump) and CN4 (DHW pump). See Figure 46 and Electrical Wiring Diagram, Figure 51.

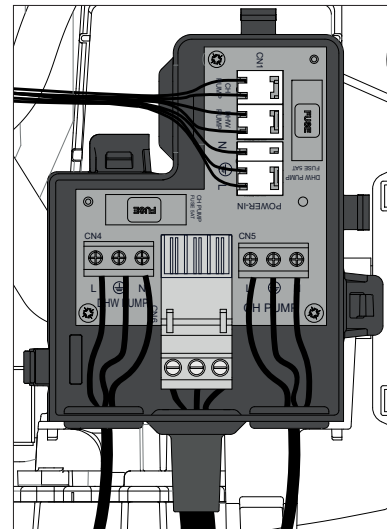

**Figure 46 - 120V Connections for DHW and CH Circulators**

7. Verify that the new cable is correctly positioned inside the control panel.
8. Reconnect the cover of the junction box.
9. Reinstall the boiler front cover
10. Restore gas to the boiler.
11. Restore power to the boiler.

**2. Low Voltage Wiring Connections**

To access the low voltage wiring connections:

1. Shut off the power supply at the boiler and at the circuit breaker.
2. Shut off the gas at the manual shutoff.
3. Remove the boiler front cover.
4. Remove the screw securing the control panel to the cross-member.
5. Push in the tabs and pull the control panel housing forward.
6. Disconnect the two clips See Figure 47.

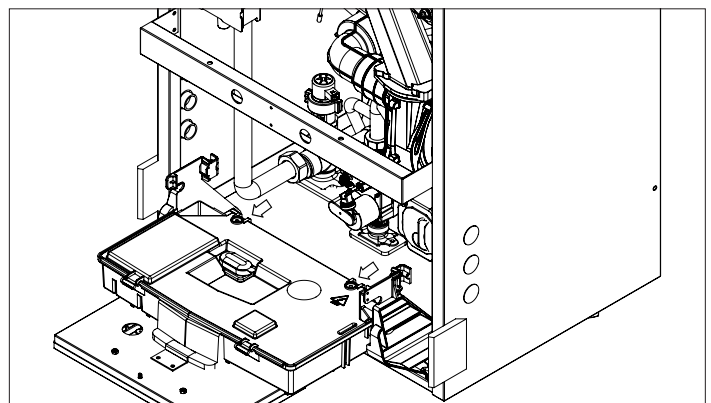

**Figure 47 - Disconnecting the Two Clips**

- Open the control panel cover to have access to the main PCB. See Figure 48.

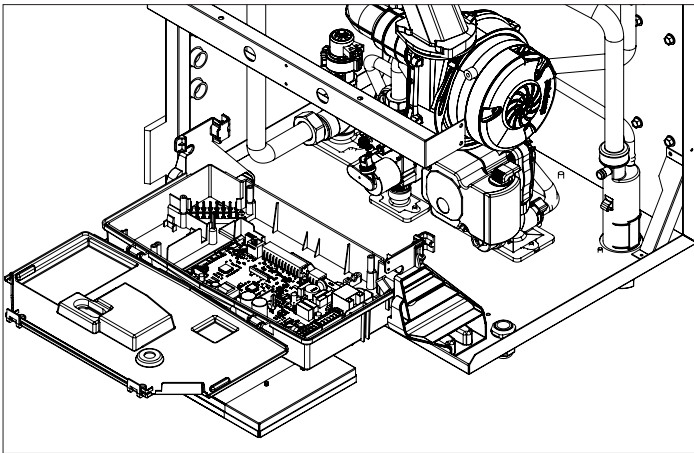

Figure 48 - Access to Low Voltage Wiring Connections

Low Voltage Wiring Connections	
<b>BUS</b>	Remote Control Connection
<b>TT2</b>	Room Thermostat 2
<b>OD</b>	Outdoor Sensor
<b>TNK</b>	Tank Temperature Sensor (Probe / Aquastat)
<b>SYS</b>	System Sensor (Cascade Manager)
<b>TT1</b>	Room Thermostat 1

Table 18 - Low Voltage Wiring Connections

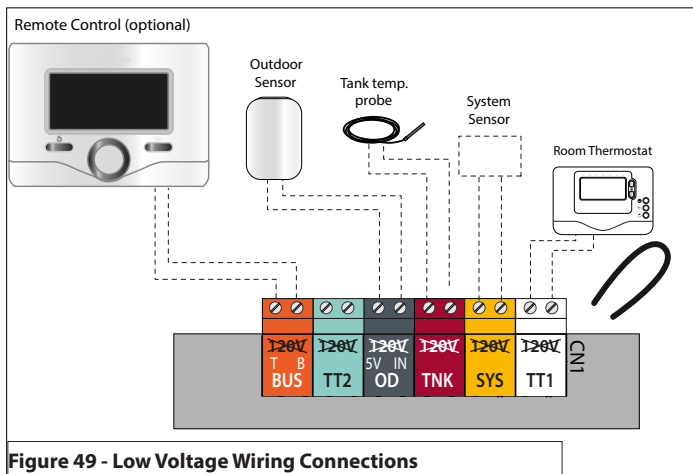

Figure 49 - Low Voltage Wiring Connections

## CAUTION

DO NOT CONNECT 120V TO ANY CONTROL WIRING CONNECTION! DOING SO WILL RESULT IN IMPROPER OPERATION AND POSSIBLE DAMAGE TO THE BOILER. SUCH DAMAGES ARE NOT COVERED BY PRODUCT WARRANTY!

### 3. Room Thermostat Wiring Connections

To connect a room thermostat:

- Access the low voltage wiring connections by following the directions in Item 2, Low Voltage Wiring Connections.
- Loosen the cable clamp using a screwdriver and insert the wires leading from the room thermostat.
- Connect the room thermostat wires to the terminals indicated in Table 18 and Figure 49.
- Ensure that the wires are well connected and not subject to stress when the control panel or cabinet cover are closed.

## CAUTION

NOTE: Some newer thermostat models may draw too much power from the boiler and will require an additional power supply to operate properly. Review the instructions provided with the thermostat to determine if an additional power supply is needed. Failure to do so could result in improper boiler and/or thermostat operation.

### 4. Outdoor Sensor Connections

NOTE: WHEN CONNECTING THE BOILER TO EXTERNAL CONTROLS, DO NOT RUN 120V CABLES AND CABLES FOR CONTROL CIRCUITS (WHICH ARE LOW VOLTAGE) TOGETHER. USE SEPARATE CABLES TO PREVENT INDUCED VOLTAGE ON THE LOW VOLTAGE CIRCUITS.

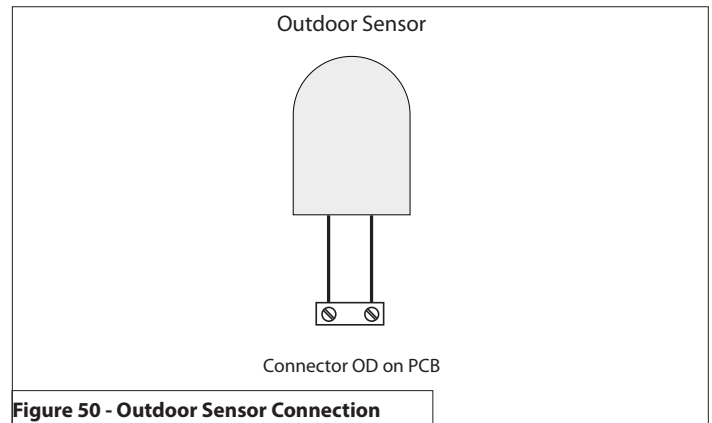

Figure 50 - Outdoor Sensor Connection

### 5. Aquastat (Default) and Tank Sensor (Optional) Connections (non-Combi Models)

The boiler is designed for managing the production of domestic hot water via an indirect water heater (IWH) in one of two ways:

**i. AQUASTAT (default)** - with parameter 228 = 2, the tank temperature is managed through an ON/OFF aquastat installed in the tank.

When an aquastat is equipped, the boiler target temperature for DHW IWH demands can be adjusted via parameter 2.10.1 - default setting is 179°F.

**ii. TANK SENSOR (optional)** - with parameter 228 = 1, the boiler manages the IWH temperature directly via an NTC sensor installed in the tank and connected to the boiler (see electrical diagram). The setting of the tank temperature is done through the "+" and "-" buttons on the left side of the display.

When a tank sensor is equipped, the boiler target temperature for DHW IWH demands can be adjusted via parameter 2.10.1 - default setting is 179°F.

# Part 7 - Connecting Electrical Service

## B. Internal Wiring Details

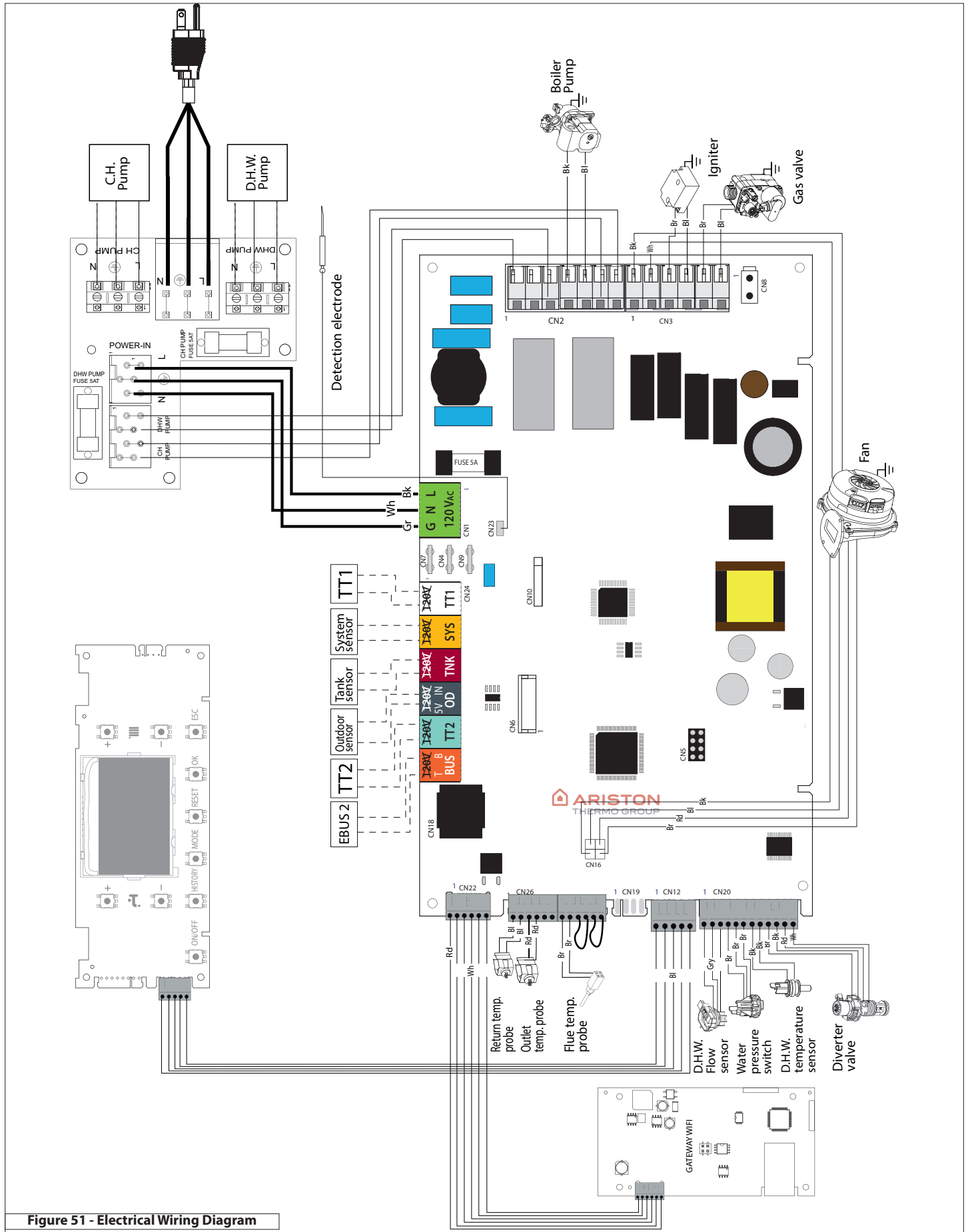
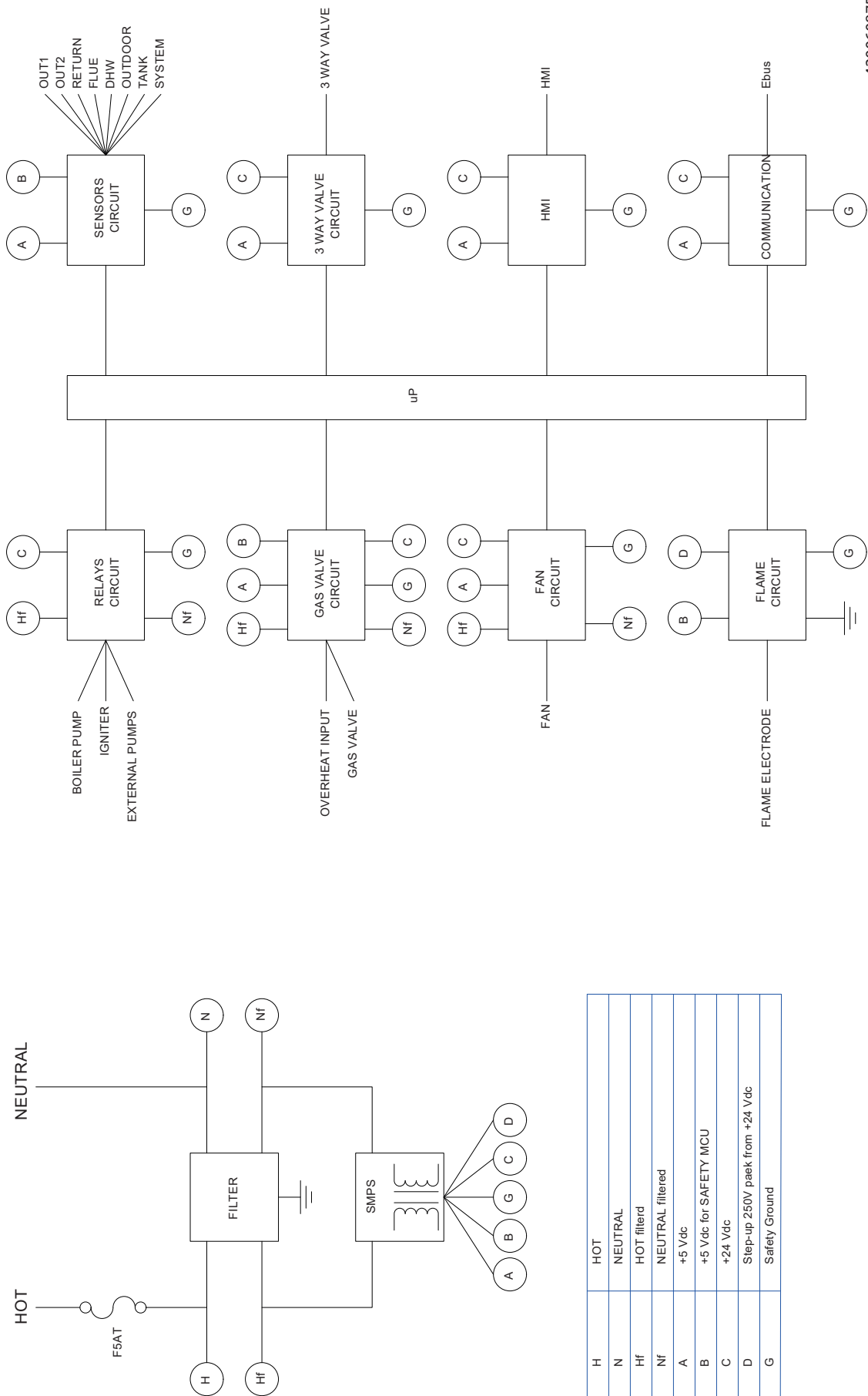

Figure 51 - Electrical Wiring Diagram



420060875300

Figure 52 - Ladder Diagram

## Part 7 - Connecting Electrical Service

Connector		Pin	Description	HT Selv
No. of Location				
CN1	POWER SUPPLY	1	120 VAC LIVE INPUT	HT (120V~) AC
		2	120 VAC NEUTRAL INPUT	
		3	PROTECTIVE EARTH	
CN2	EXTERNAL PUMP 2 / Hi-V DIVERTER VALVE (DHW)	1	120 VAC EXT. PUMP2 INPUT / 120VAC LINE DIV1	HT (120V~) AC
		2	120 VAC NEUTRAL	
		3	120 VAC EXT. PUMP2 (NO) / 120VAC LINE DIV2	
	BOILER PUMP	4	120 VAC LIVE (NO)	
		5	120 VAC NEUTRAL	
	EXTERNAL PUMP 1 (CH)	6	120 VAC EXT. PUMP1 INPUT	
		7	120 VAC EXT. PUMP1 (NO)	
CN3	FAN ON/OFF	1	120 VAC LIVE	HT (120~) AC
		2	120 VAC NEUTRAL	
	IGNITER	3	120 VAC LIVE (NO)	
		4	120 VAC NEUTRAL	
	GAS VALVE	5	120 VRAC + (NO)	
		6	120 VRAC - (NO)	
CN8	POWER SUPPLY OUT	1	120 VAC LINE	HT (120V~) AC
		2	120 VAC NEUTRAL	
CN4	PROTECTIVE EARTH	1		
CN7	PROTECTIVE EARTH	1		
CN9	PROTECTIVE EARTH	1		
CN26	NTC HEAT RETURN	1	+5V	SELV (5V)
		2	CH RETURN NTC SENSOR SIGNAL	
	NTC HEAT FLOW 1	3	+5V	
		4	CH FLOW 1 NTC SENSOR SIGNAL	
		5	NOT USED	
		6		
	NTC FLUE	7	+5V	
		8	FLUE NTC SENSOR SIGNAL	
	AIR PRESSURE SWITCH (Bridged on 150, 199, and 199C models)	9	+24V	SELV (24V)
		10	APS DETECTION SIGNAL	
	Bridged	11	DO NOT REMOVE	
		12		
CN20	DHW FLOW SENSOR	1	+5V	SELV (5V)
		2	GROUND	
		3	DHW FLOW DETECTION SIGNAL	
	WATER PRESSURE SWITCH	4	+5V	
		5	GROUND	
		6	CH WATER PRESSURE SWITCH SIGNAL	
	NTC HEAT DHW	7	+5V	
		8	DHW OUTLET NTC SENSOR SIGNAL	
	DIVERTER VALVE	9	STEPPER DIVERTER VALVE COIL 1 START	
		10	STEPPER DIVERTER VALVE COIL 1 END	
		11	STEPPER DIVERTER VALVE COIL 2 START	
		12	STEPPER DIVERTER VALVE COIL 2 END	

Table 19 - Boiler Wiring - 1



Connector		Pin	Description	HT Selv
No. of Location				
CN24	ROOM THERMOSTAT	1	+24V	SELV (24V)
		2	ROOM THERMOSTAT 1 SIGNAL	
	NTC SYSTEM	3	+5V	SELV (5V)
		4	CASCADE NTC SENSOR SIGNAL	
	NTC TANK	5	+5V	
		6	BOILER NTC SENSOR SIGNAL	
	OUTDOOR SENSOR	7	+5V	
		8	OUTDOOR NTC SENSOR SIGNAL	
	ROOM THERMOSTAT 2	9	+24V	SELV (24V)
		10	ROOM THERMOSTAT 2 SIGNAL	
	EBUS2	11	EBUS2 SIGNAL	SELV (24V)
		12	GROUND	
CN16	FAN MANAGEMENT	1	GROUND	SELV (24V)
		2	PWM FAN-DRIVER	
		3	HALL_EFFECT SENSOR	
		4	+24V	
CN19	EXTERNAL CLIP-IN	1	+24V	SELV (24V - 5V)
		2	GROUND	
		3	CLIP-IN SERIAL TX SIGNAL	
		4	CLIP-IN SERIAL RX SIGNAL	
CN12	HMI	1	+5V	SELV (24V - 5V)
		2	GROUND	
		3	HMI SERIAL TX SIGNAL	
		4	HMI SERIAL RX SIGNAL	
		5	+24V	
CN22	PWM PUMP	1	PWM PUMP SIGNAL	SELV (24V)
		2	NOT USED	
		3	GROUND	
CN23	FLAME	1	FLAME SENSOR SIGNAL	HT (110Vrms) AC
CN18	SERVICE TOOL SERIAL INTERFACE	1	+5V	SELV (24V - 5V)
		2	GROUND	
		3	MODE	
		4	SERIAL TX SIGNAL TO PC	
		5	SERIAL RX SIGNAL FROM PC	
		6	+24V	

**Table 20 - Boiler Wiring - 2**

**! WARNING**

**FIRE AND/OR EXPLOSION HAZARD**

To avoid serious injury or death, the gas line installation and the gas line inlet pressure test must be done by a licensed professional.

Ensure the gas on which the boiler will operate is the same type specified on the rating plate (natural gas or LP gas). This boiler must be converted to propane operation. Follow Gas Conversion Manual instructions (separate document). Failure to follow these instructions could result in property damage, personal injury, or death.

**! WARNING**

Make sure the gas line pressures are within normal limits. Pressures outside normal limits can result in poor performance and hazardous operating conditions, property damage, personal injury, or death.

**NOTICE**

Do not operate the boiler on Natural Gas or LP gas with average sulfur rates greater than 30 mg/m<sup>3</sup>. Doing so could result in improper product operation and failure, and WILL VOID the boiler warranty.

**A. Gas Pipe Sizing Tables**

**1. Gas Pipe Sizing**

This information is for reference use only. Refer to gas pipe manufacturer specifications for actual delivery capacity. The DOE standard for Natural Gas is 1100 BTU/ft<sup>3</sup>. Contact the local gas supplier for actual BTU/ft<sup>3</sup> rating.

**2. Natural Gas Pipe Sizing**

The following tables list maximum capacity of pipe in cubic feet of gas per hour for gas pressures of 14" or less and a pressure drop of 0.5 inches water column, based on a 0.60 specific gravity for natural gas.

Pipe Size (in.)	Length of Pipe (Feet)										BTU's Per Hour x 1,000  Schedule 40 Metallic Pipe  (0.60 Specific Gravity, 0.5 WC Pressure Drop)
	10	20	30	40	50	60	80	100	150	200	
3/4	360	247	199	170	151	137	117	104	83	71	
1	678	466	374	320	284	257	220	195	157	134	
1 1/4	1390	957	768	657	583	528	452	400	322	275	
1 1/2	2090	1430	1150	985	873	791	677	600	482	412	
2	4020	2760	2220	1900	1680	1520	1300	1160	928	794	
3	11300	7780	6250	5350	4740	4290	3670	3260	2610	2240	
4	23100	15900	12700	10900	9660	8760	7490	6640	5330	4560	

Table 21 - Natural Gas Delivery Capacity - Refer to ANSI Z223.1 - National Fuel Gas Code, Latest Edition

**3. LP (Liquid Propane) Gas Pipe Sizing**

Contact gas supplier to size pipes, tanks, and 100% lockup gas pressure regulator. Adjust propane supply regulator provided by the gas supplier for 14 inches w.c. maximum pressure.

**B. Gas Connection Requirements**

- The gas connection fitting is 3/4" NPT.  
**NOTE:** The gas pipe size must not be less than 3/4".  
**NOTE:** DO NOT USE 1/2" quick flex gas lines! Doing so will result in improper appliance operation.
- The supply line must be sized for the maximum input of the boiler being installed. If there are additional gas appliances on the main supply line, measure the size of the supply line according to the COMBINED total maximum BTUH draw for the appliances as if they were operating at the same time.
- Measure the length of the gas supply line from the gas meter to the boiler. The boiler must be installed downstream of the gas meter to ensure adequate gas supply. Use the tables in this manual or refer to the gas line manufacturer's sizing information to determine the correct supply pipe size.
- The National Fuel Gas Code (NFPA 54) requires that a sediment trap (drip leg) be installed in the gas line on boilers not so equipped. The drip leg must be accessible, a minimum of 3" in length, and not subject to freezing conditions. See Figure 53.

- A manual gas shut-off valve should be installed in the gas supply line close to the boiler. See Figure 53.
- To facilitate any future maintenance, it is also recommended that an approved gas union fitting be installed in the supply line between the shut-off valve and the 3/4" NPT connection on the boiler.

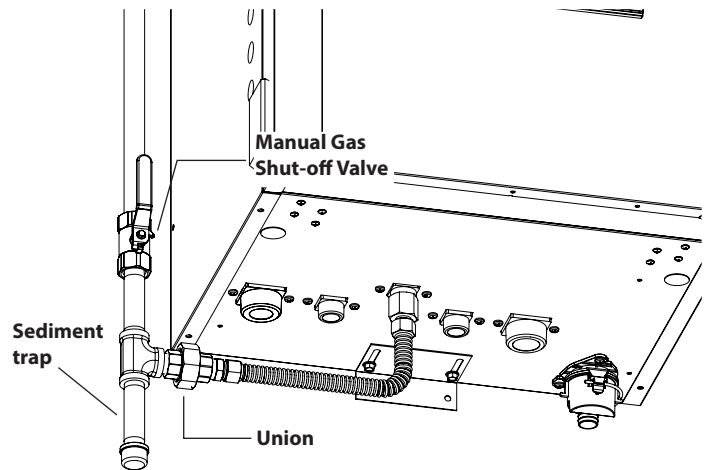

Figure 53 - Gas Line with Shut-Off and Sediment Trap Detail

7. Use a manometer to test the gas pressure to make sure it meets the minimum standards and does not exceed the maximum standards of the boiler.
8. Leak test the gas line pipe before placing the boiler in operation. Only use approved leak detector liquid solutions to check for leaks.
9. Do not operate the boiler until all connections have been completed and the heat exchanger is filled with water.

**C. Additional Precaution for Excess Flow Valve (EFV)**

If an excess flow valve (EFV) is in the gas line, check the manufacturer's minimum and maximum flow capacity ratings. An improperly sized EFV will not allow for a full flow of gas to the boiler and will cause the boiler to malfunction. See Figure 54.

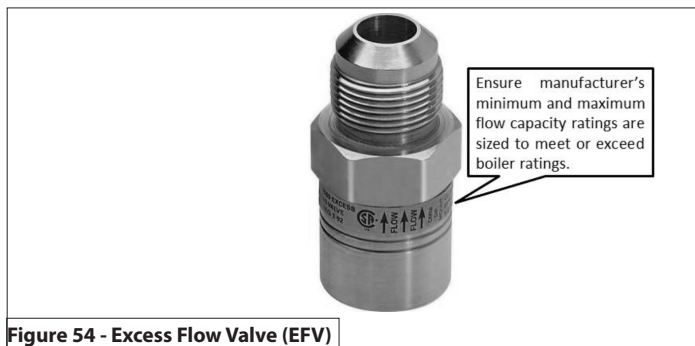

Figure 54 - Excess Flow Valve (EFV)

**! WARNING**

When performing a pressure test on the gas line piping, be sure the boiler is disconnected or isolated if the test pressure is expected to exceed 1/2 PSI (14" WC), as damage to the gas valve could occur. Such damage could result in fire, property damage, serious personal injury, or death.

**D. Checking Gas Pressure at the Boiler for Proper Operation**

**NOTE:** Refer to Figure 55 when checking gas pressure. Loosen the bolts before checking the gas inlet pressure.

1. The boiler and its individual shutoff valve must be disconnected from the gas supply piping system during any pressure testing of the system at test pressures greater than 1/2 psi (3.5 kPa).
2. The boiler must be isolated from the gas supply piping system by closing its individual manual shutoff valve during any pressure testing of the gas supply piping system at test pressures equal to or less than 1/2 psi (3.5 kPa).

The minimum and maximum inlet gas line pressures must meet the requirements shown in Table 22.

Natural Gas	
Minimum Pressure	3.5"WC
Maximum Pressure	10.5"WC
LP Gas	
Minimum Pressure	8"WC
Maximum Pressure	13"WC

Table 22 - Gas Pressure Requirements

**NOTICE**

Do not fire (operate) the boiler until all connections have been completed and the heat exchanger is filled with water. Doing so will damage the boiler and void the warranty.

**! WARNING**

DO NOT REMOVE OR ATTEMPT TO MAKE AN ADJUSTMENT TO SCREWS 2 and 4 WITHOUT A CALIBRATED COMBUSTION ANALYZER. DOING SO COULD RESULT IN FIRE, PROPERTY DAMAGE, SERIOUS PERSONAL INJURY, OR DEATH.

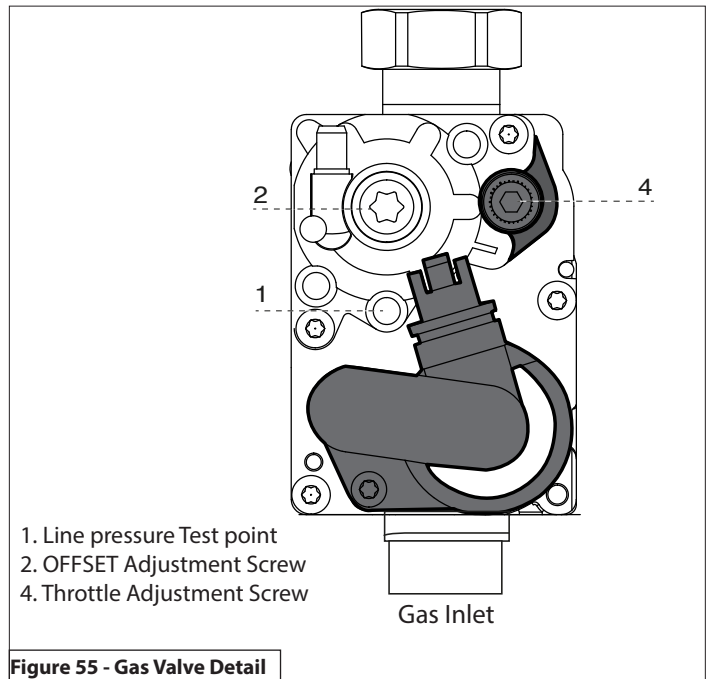

1. Line pressure Test point
2. OFFSET Adjustment Screw
4. Throttle Adjustment Screw

Figure 55 - Gas Valve Detail

A. Control and Display Overview

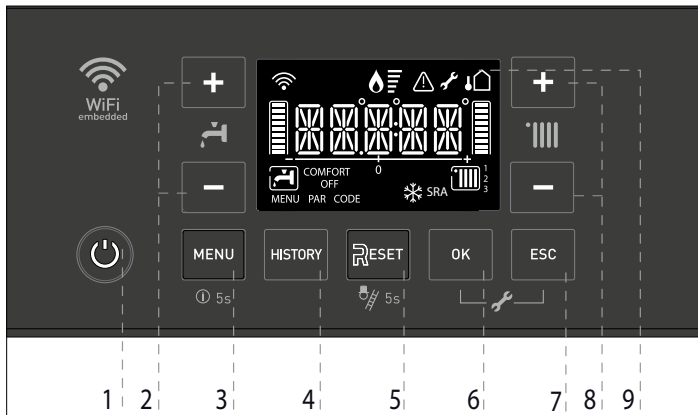
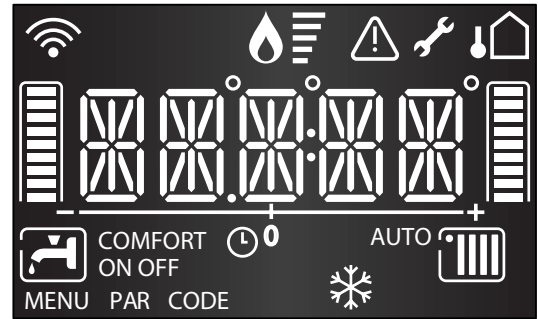

Figure 56 - Control and Display Overview

Item #	Description
1	ON / OFF Button (see NOTICE below)
2	Domestic Hot Water Adjustment Button +/-
3	MENU (short press = User Menu); (long press = Info Menu)
4	HISTORY Button - view last 10 errors
5	RESET Button (see NOTICE below)
6	OK – confirms menu selection
7	ESC – exits menu selection
8	Heating Temperature Adjustment Button +/-
9	Display

Table 23 - Control Descriptions

NOTICE	
Operating Description	
	<b>On / Off Button</b> The button lights (white) when the boiler is electrically powered.
	<b>On / Off Button</b> The button is not lit in the event of an error or power failure.
	<b>RESET BUTTON</b> The button lights (red) in the event of a lockout error. After pressing the Reset button to clear an error condition, the button will flash for five (5) seconds.



Display Icon	Description
	Digits Indicating: <ul style="list-style-type: none"> <li>Boiler Status</li> <li>Temperature (°F) with bar level</li> <li>Error Codes (ERROR)</li> <li>Press Reset Button Request (RESET) (boiler lockout)</li> <li>Menu Settings</li> </ul>
	Technical assistance request
	Flame detected with indication of power level
	CH Heating Operation Set
	CH Heating Operation Active
	DHW Operation Set
	DHW Operation Active
<b>COMFORT</b>	Hot Water Comfort Activated (Combi Only)
<b>OFF</b>	Boiler off with Antifreeze Function Active
	Antifreeze Function Active
<b>AUTO</b>	Automatic Temperature Control activated
	Error signal - Display will also show a code and description
	Outdoor Sensor Connected - Optional
	WiFi Active

Table 24 - Display Icon Descriptions

### B. Ignition Procedure

Press the ON/OFF button  on the control panel to power on the boiler. The display shows the current operating mode.

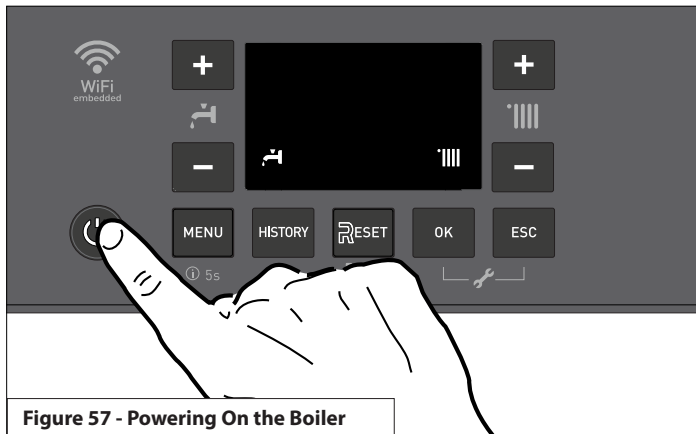







Figure 57 - Powering On the Boiler

### Operating Mode

Description	Display
Stand-by	
CH request supply temperature displayed	
DHW request DHW setpoint displayed	
Purging Cycle	
Central Heating Post Circulation	
DHW Circuit Post Circulation	

### C. Central Heating (CH) Temperature Adjustment

It is possible to adjust the central heating (CH) temperature setpoint from the home screen by pressing the CH +/- buttons. See Figure 58. The allowable operating range is limited by the Max and Min Temperature Settings (e.g., Parameters 4.2.5 and 4.2.6) which are adjustable via the Technical Menu. See P. Technical Menu - Access and Navigation.

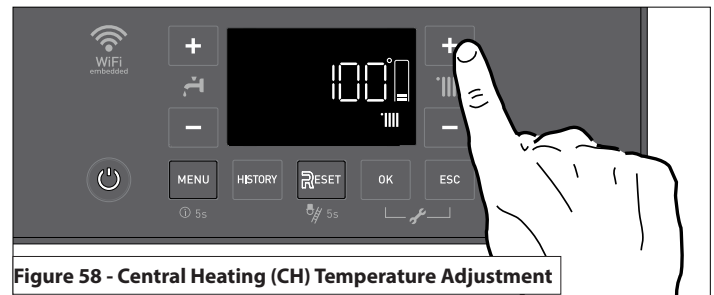

Figure 58 - Central Heating (CH) Temperature Adjustment

**NOTE:** When set to AUTO - Automatic Temperature Control (e.g., Outdoor Reset), the CH Temperature Setpoint is calculated in accordance with the type of automatic temperature control selected. The resulting setpoint can be offset/shifted up or down by pressing the CH +/- buttons from the home screen. See K. Parallel Shift of Reset Curve.

### D. Domestic Hot Water (DHW) Temperature Adjustment

#### Not Applicable to Non-Combi Models using an Aquastat

It is possible to adjust the domestic hot water (DHW) temperature setpoint from the home screen by pressing the DHW +/- buttons. See Figure 59.

The DHW temperature range is 97 - 140°F. The previously set value will flash on the display.

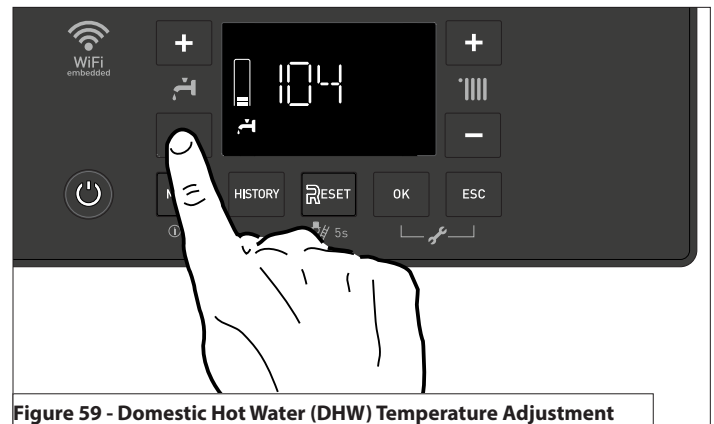
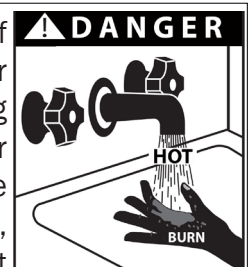

Figure 59 - Domestic Hot Water (DHW) Temperature Adjustment

## DANGER

Hotter water increases the risk of scald injury. Scalding may occur within five (5) seconds at a setting of 140°F. Water temperature over 125°F can instantly cause severe burns or death from scalds. Children, disabled, and elderly persons are at the highest risk of being scalded.

See instruction manual before setting temperature at the appliance. Feel water before bathing or showering.



## Part 9 - Controls

Approximate Time / Temperature Relationships in Scalds	
120°F	More than 5 minutes
125°F	1 1/2 to 2 minutes
130°F	About 30 seconds
135°F	About 10 seconds
140°F	Less than 5 seconds
145°F	Less than 3 seconds
150°F	About 1 1/2 seconds
155°F	About 1 second

Table 25 - Time and Temperature Relationship in Scalds

## ! WARNING



An ASSE 1017 or ASSE 1070 temperature limiting or mixing valve is recommended in installations servicing disabled or elderly persons, or children. Mixing valves do not eliminate the risk of scalding. To avoid scalding:

- Set the water heater set point temperature as low as possible.
- Feel water before bathing or showering.
- If thermostatic valves are required, use devices specifically designed for such purpose. Install these devices in accordance with instructions provided by the manufacturer.



Failure to install a temperature limiting or mixing valve and follow these instructions could result in property damage, severe personal injury, or death due to scalds.

### E. User Menu

Press the MENU button to open the user menu.

To navigate within the menu or parameters, press the + and - buttons (  or  ).

To change a parameter, select it by pressing the OK button.

To change the set value, press the + and - buttons (  or  ).

Press the OK button to save.

To exit without saving the changes, press the ESC button.

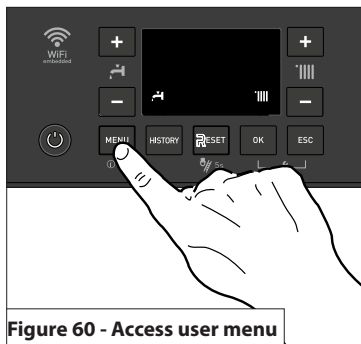



Figure 60 - Access user menu

For parameters 4 to 11 in Table 26, it is also possible to adjust the same parameters for Zones 2 and 3, if applicable.

**NOTE:** Zone 3 is only applicable when using an optional NTI zone controller.

By pressing the HISTORY button after accessing the parameter, the number 1 or 2 of the selected zone appears next to the heating symbol:  / .

Continue to change the setting as described above.

Activate change by pressing the **OK** button. + / - buttons scroll through and change values. Press **OK** button to confirm a change. Press **ESC** to return without change.







































1. I-NET		
	WIFI	ON/OFF Wi-Fi
	AP	Access point open for 10 minutes
	SN	Shows Wi-Fi (Not Appliance) serial number
	RESET	Delete Wi-Fi settings and Disconnect user account
	ITIME	ON/OFF - Date and time set via the Internet.
	ITEMP	Use Internet weather (only without outdoor sensor)
2. Date and Time (Only visible when ITIME is set to OFF)		
	The following values are displayed in a sequence.	
	Day (1-31)	
	Month (1-12)	(*) Press +/- button for setting hours
	Year (year)	Press +/- button for setting the minutes)
	Time (hh: mm) (*)	Press OK to confirm the entered data.
3. DHW Comfort Function (Only applicable with Combi models)		
	OFF	DHW Comfort function deactivated
	ON	DHW Comfort function Active
4. Time programs – DHW Comfort Function  (Only visible with Combi models - Not Operable)		
	0+24 h	Always active
	P1	Family program
	P2	Program no lunch
	P3	Program with lunch
	06-22 h	DHW Comfort active from 06:00 to 22:00
5. Automatic C.H. temperature control / AUTO function 		
	OFF	AUTO function deactivated
	ON	AUTO function Active (AUTO appears on the display)
6. Room temperature Day  /  <sup>1</sup> /  <sup>2</sup> only applicable if using NTI room sensor(s)		
7. Room temperature Night  /  <sup>1</sup> /  <sup>2</sup> only applicable if using NTI room sensor(s)		
8. Time programs – heating schedule  /  <sup>1</sup> /  <sup>2</sup>  only applicable if using NTI room sensor(s)		
	0+24 h	Always active
	P1	Family program
	P2	Program no lunch
	P3	Program with lunch
	06-22 h	C.H. active from 06:00 to 22:00
	P EXT	Time program defined by REMOCON room unit or NTI NET app.
9.  /  <sup>1</sup> /  <sup>2</sup> Outdoor Reset Curve Slope (only with AUTO function active)  /  <sup>1</sup> /  <sup>2</sup>		
10.  /  <sup>1</sup> /  <sup>2</sup> Outdoor Reset Curve Parallel Shift (only with AUTO function active)  /  <sup>1</sup> /  <sup>2</sup> Setting range + -7 at low temperature and + -14 at high temperature range (each step + or - 1.8°C)		
11.  /  <sup>1</sup> /  <sup>2</sup> Automatic summer / winter changeover  /  <sup>1</sup> /  <sup>2</sup>		
	ON	Active
	OFF	Function deactivated
12.  /  <sup>1</sup> /  <sup>2</sup> Summer / winter changeover temperature  /  <sup>1</sup> /  <sup>2</sup>		

Table 26 - User Menu



**F. INFO Menu**

Press the MENU button for 5 seconds to access the **INFO** menu, navigate within the **INFO** menu with + and - (both possible,  or .

Attention: No values can be changed here, only information can be read! Changes can only be made in the user menu or in the specialist area.

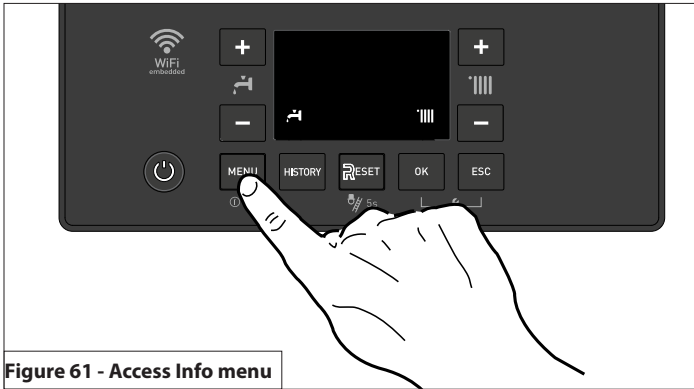

Figure 61 - Access Info menu

Info Menu	Parameter	Description
01.	8.5.7	Floor drying remaining days (with Floor Drying function active)
06.	8.3.1	Supply water temperature [°F]
07.	8.3.2	Return water temperature [°F]
08.	8.3.3 / 8.4.0	DHW outlet or storage temperature [°F]
09.	8.3.5	Outdoor temperature [°F]
10.	8.3.4	Exhaust flue temperature [°F]
11.	8.7.8	Burner power level [%]
12.	4.3.0/5.3.0	Room temperature [°F] (only with NTI Room Sensor connected) (Zone 1/2)
13.	8.2.5	DHW flow rate [gpm] (TRX199C only)
18.	8.2.2	Actual fan speed [RPM/10]
20.	8.7.9	Burner flame signal

Table 27 - Info menu

**G . Date and Time (If ITIME is set to OFF)**

The control unit is equipped with a 365-day clock that displays the day, month, year and time.

In order to ensure correct operation of the boiler when using time programs, the date and time must be set correctly. If the boiler is connected to the Wifi application, the Internet time is automatically taken into account. Manual entry:

Day (1-31)

Months (1-12)

Year (2019)

Time (00:00)

Buttons  /   (item 2 - Figure 56)  
for the hour setting

Buttons  /   (item 8 - Figure 56)  
for setting minutes

## Part 9 - Controls

### H. Automatic CH Temperature Control (AUTO)

The Automatic Temperature Control (AUTO) function allows the boiler to automatically adjust the target temperature of each heating zone to adapt to outdoor and/or indoor temperature conditions and/or heat demand cycles.

Select the type of Temperature Control via parameters 4.2.1 (Zone 1), 5.2.1 (Zone 2), or 6.2.1 (Zone 3). The default setting is 3 - Outdoor Reset. See Table 28.

**NOTE:** Automatic Temperature Control is only possible when the AUTO function is turned ON. To activate the AUTO Function, set to "ON" via the User Menu, or set parameter 2.2.4 = 1 via the technical menu.

### NOTICE

In order for the boiler to detect changes in room temperature it is necessary to install an NTI Room Sensor. Other thermostats (not NTI) can only switch the boiler ON and OFF.

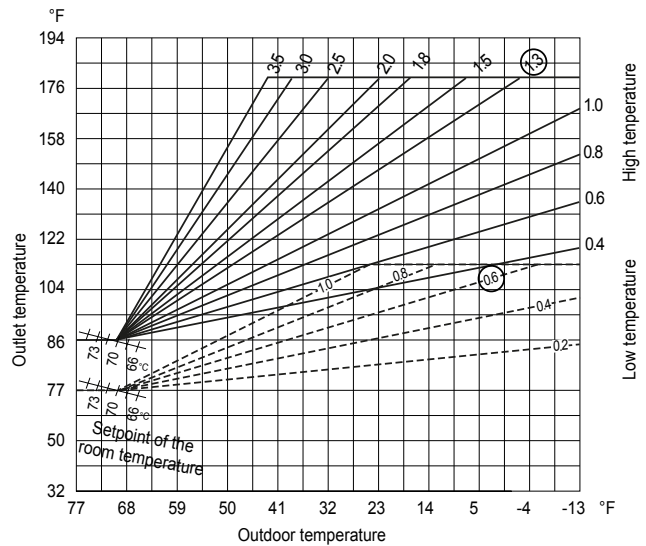

Figure 62 - Reset Slopes

### Parameters of Automatic CH Temperature Control

#### Example: Zone 1 - 400 Level Parameters

**NOTE:** Zones 2 and 3 can be changed in the equivalent 500 and 600 level parameters, respectively

Parameter	Range	Factory Settings
<b>4 Zone 1</b>		
<b>4.2 Zone 1 Settings</b>		
4.2.0 Temperature Range	0 = Low Temperature (LT 68-122°F) 1 = High Temperature (HT 86-179°F)	Select the range that best matches the needs of the heating zone. 1 (HT)
4.2.1 Type of Temperature Control*	0 = Fixed Outlet Temperature - Automatic Temperature Control (AUTO) OFF 1 = Basic Temp. Control (without Optional Room Sensor or Outdoor Sensor) 2 = Indoor Temp. Reset (With Optional Room Sensor) 3 = Outdoor Temp. Reset (With Included Outdoor Sensor or weather from the internet if the boiler is connected to WiFi) 4 = Indoor and Outdoor Temp. Reset (With Optional Room Sensor and Included Outdoor Sensor or weather from the internet if the boiler is connected to WiFi)	3
4.2.2 Slope of Outdoor Reset Curve	0.2 - 0.8 (when 4.2.0 = 0) 0.4 - 3.5 (when 4.2.0 = 1)	The greater the slope, the quicker the boiler target temperature rises as the outdoor temperature decreases. Applicable when 4.2.1 = 3 or 4. 1.3 (HT) 0.6 (LT)
4.2.3 Parallel Shift of Reset Curve	-12 to +12 (when 4.2.0 = 0) -25 to +25 (when 4.2.1 = 1)	Provides a means of adjusting (shifting) the calculated reset boiler target temperature up or down. Applicable when 4.2.1 = 1, 2, 3, or 4. 0
4.2.4 Room Sensor Influence	0 - 20	Adjusts the influence of room temperature on target boiler temperature - a higher setting causes a greater increase to the boiler target temperature as the indoor temperature drops below room setpoint. Applicable when 4.2.1 = 2 or 4. 4 (HT) 2 (LT)
4.2.5 Maximum Temperature Setting	68-122°F (when 4.2.0 = 0) 86-179°F (when 4.2.0 = 1)	179 (HT) 120 (LT)
4.2.6 Minimum Temperature Setting	68-122°F (when 4.2.0 = 0) 86-179°F (when 4.2.0 = 1)	120 (HT) 80 (LT)
<b>4.7 Zone 1 Regulation Parameters</b>		
4.7.5 Auto Boost	0 = OFF 1 = ON	When ON, the boiler automatically adjusts the slope based on the 4.2.2 parameter setting. The slope increases 10% for every 10 minutes a call for heat is active, and decreases 1% every minute after the call for heat has been satisfied. 0

Table 28 - Default Parameters for the Heating System Zone 1 - \*See the Following Page for Description of 4.2.1

**I. Type of Temperature Control**

(e.g. Parameter 4.2.1 for Zone 1)

**0 = Fixed Outlet Temperature** - When operating for central heating, the boiler operates at a fixed supply temperature equal to the setting of parameter 4.0.2, which is adjustable via the CH + and - buttons on the home screen, with a range defined by parameters 4.2.5 and 4.2.6. The supply temperature is fixed and does not change due to indoor or outdoor temperature conditions.

**1 = Basic Temp. Control** - The boiler uses the ON/OFF condition of the room thermostat to boost/reduce the boiler target temperature. With a starting\* (first time) boiler target temperature of 136°F (4.2.0 = 1) or 95°F (4.2.0 = 0), the function boosts the target temperature by 7°F every 16 minutes\*\* a call for heat is continuously active. Similarly, the target temperature is reduced 7°F every 16 minutes\*\* that the heat call is continuously inactive. The temperature will boost/reduce a maximum of 3 times (21°F)\*\*\* for a given thermostat ON/OFF cycle.

**\*NOTE:** The boiler starting target temperature can be manually offset up or down via the Parallel Shift setting (4.2.3), which is adjustable from the home screen via the CH + and - buttons.

**\*\*NOTE:** The default boost interval of 16 minutes can be adjusted via parameter 2.4.4.

**\*\*\*NOTE:** The boiler supply temperature is limited upwards by the fixed maximum temperature (4.2.5) and downwards by the fixed minimum temperature (4.2.6).

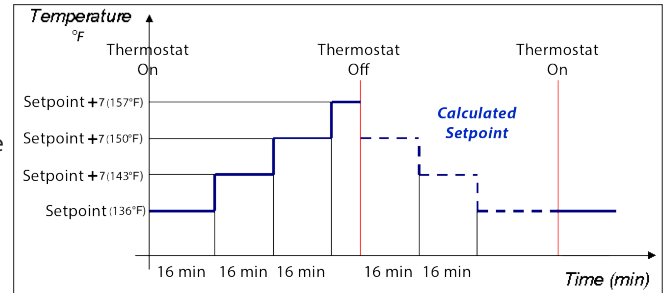

Figure 63 - Basic Temp. Control Example (4.2.0 = 1)

**2 = Indoor Temp. Reset** - The boiler target temperature automatically adjusts between the Min and Max Temperature Settings (4.2.6 and 4.2.5), based on the input temperature provided by an optional NTI Room Sensor, in accordance with the following formula:

$$\text{Boiler Target Temp} = \text{Min Temp (4.2.6)} + \text{Room Sensor Influence (4.2.4)} \times [\text{Room Setpoint} - \text{Room Temp}] + \text{Parallel Shift of Reset Curve (4.2.3)}$$

**3 = Outdoor Temp. Reset** - The boiler target temperature automatically adjusts between the Min and Max Temperature Settings (4.2.6 and 4.2.5), based on the input temperature provided by the included Outdoor Sensor (or Internet Weather via WiFi connection), in accordance with the following formula:

$$\text{Boiler Target Temp} = \text{Min Temp (4.2.6)} + \text{Slope of Outdoor Reset Curve (4.2.2)} \times [\text{Room Setpoint (4.0.0)} - \text{Outdoor Temp}] + \text{Parallel Shift of Reset Curve (4.2.3)}$$

Where: Room Setpoint, in the absence of an NTI Room Sensor, defaults to 66°F and is adjustable via parameter 4.0.0.

**4 = Indoor and Outdoor Temp. Reset** - The boiler target temperature automatically adjusts between the Min and Max Temperature Settings (4.2.6 and 4.2.5), based upon the input temperatures provided by an optional NTI Room Sensor AND the included Outdoor Sensor (or Internet Weather via WiFi connection), in accordance with the following formula:

$$\text{Boiler Target Temp} = \text{Min Temp (4.2.6)} + \text{Slope of Outdoor Reset Curve (4.2.2)} \times [\text{Room Sensor Influence (4.2.4)} \times [\text{Room Setpoint} - \text{Room Temp}] + [\text{Room Setpoint} - \text{Outdoor Temp}]] + \text{Parallel Shift of Reset Curve (4.2.3)}$$

**J. Slope of Outdoor Reset Curve**

(e.g. Parameter 4.2.2 for Zone 1)

The boiler control adjusts the supply temperature according to the outdoor temperature. The lower the outdoor temperature, the higher the boiler supply temperature, and vice versa.

The supply temperature needed to efficiently satisfy a call for heat from a thermostat depends on the heating system and building conditions (building materials, insulation, etc.)

The Slope of the Outdoor Reset Curve may be adjusted to adapt the boiler supply temperature to installation conditions.

**NOTE:** The boiler supply temperature is limited upwards by the fixed maximum temperature (4.2.5) and downwards by the fixed minimum temperature (4.2.6).

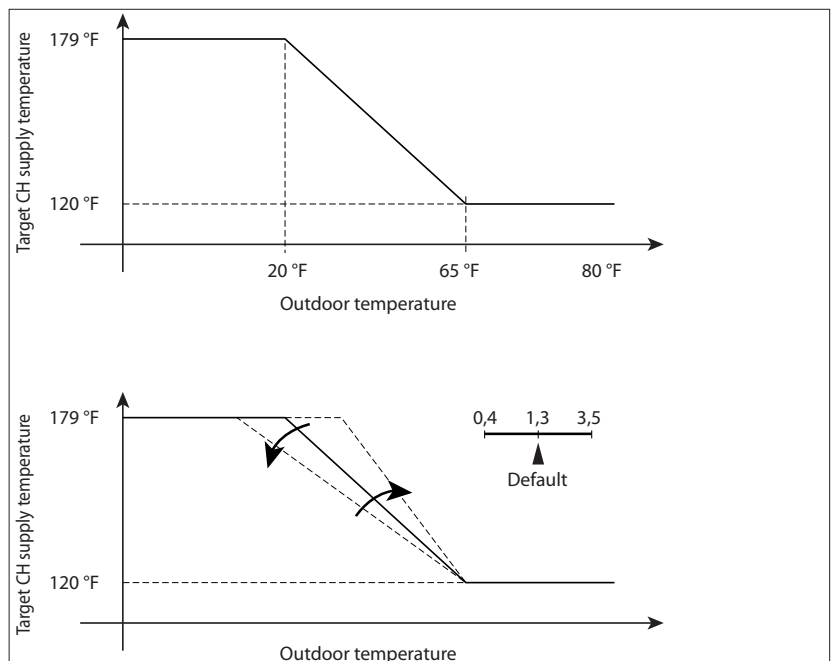

Figure 64 - Adjusting the Slope of the Outdoor Reset Curve

## K. Parallel Shift of Reset Curve

(e.g. Parameter 4.2.3 for Zone 1)

When the Reset Curve results in a boiler target temperature that is too high or too low (i.e., heats the building too quickly or slowly), Parallel Shift can be used to offset the curve up or down to increase or decrease the boiler target temperature.

**NOTE:** Adjusting Parallel Shift is only possible when Auto Boost is OFF (4.7.5 = 0).

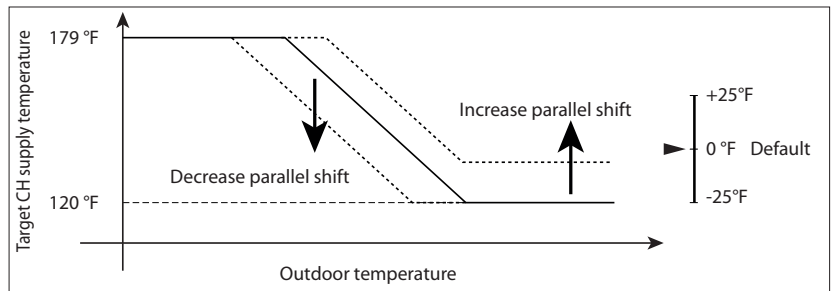

Figure 66 - Parallel Shift of Reset Curve

The Parallel Shift can be adjusted from the home screen using the CH + and - buttons (Figure 56, Item 8).

With the first press of the CH + or - button, the display shows the current CH target temperature (e.g., 130°F).

After a 3-5 second delay, the display begins flashing the current offset (Parallel Shift) setting. Subsequent CH + or - button presses adjusts the offset up or down.

After a few seconds the display shows the new CH target temperature (e.g., 138°F), then returns to the home screen.

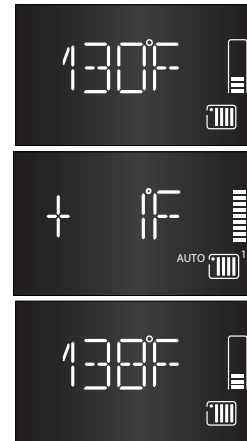

## L. Auto Boost

(e.g. Parameter 4.7.5 for Zone 1)

When enabled (4.7.5 = 1), Auto Boost acts to automatically adjust the Slope of the Outdoor Reset Curve to better match the needs of the heating system. The function boosts the boiler target temperature by increasing the Slope 10% every 10 minutes a call for heat is continuously active, to a maximum of 2X the nominal Slope setting (4.2.2). While the heat call is satisfied, the Slope decreases by 1% every minute to a minimum of the nominal Slope setting (4.2.2). Auto Boost is only applicable when 4.2.1 = 3 or 4.

**NOTE:** The boiler supply temperature is limited upwards by the fixed maximum temperature (4.2.5) and downwards by the fixed minimum temperature (4.2.6).

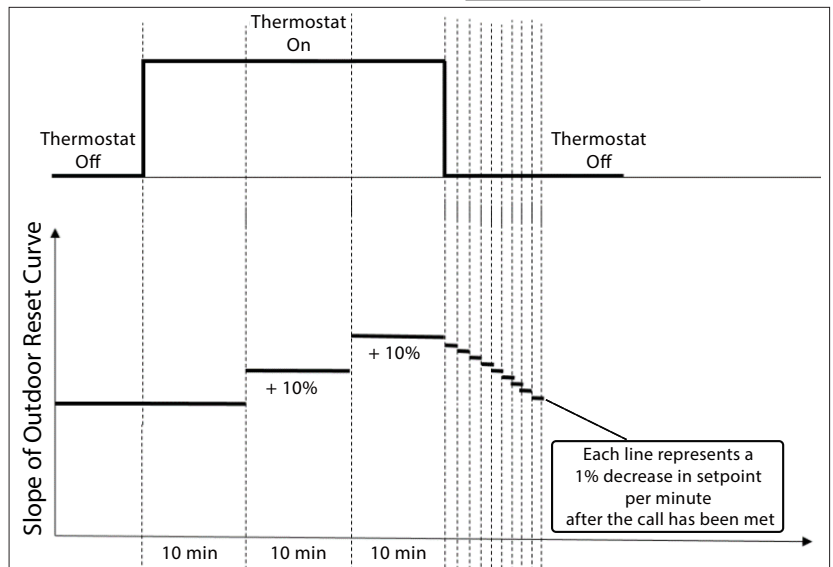

Figure 65 - Automatic Boost

**M. Room Temperature Day /Night**  
(Only applicable when using NTI room sensor)

The room temperatures (both zones 1/2) can be set to different setpoints. These setpoints become effective with the selected operating mode and the time program, so that different temperature levels can occur in each zone. The range of adjustable target values is limited by their interdependence, which can be seen in the accompanying graph.  
Daily setpoint (comfort), factory setting 70°F  
Night setpoint (reduced), factory setting 61 °F

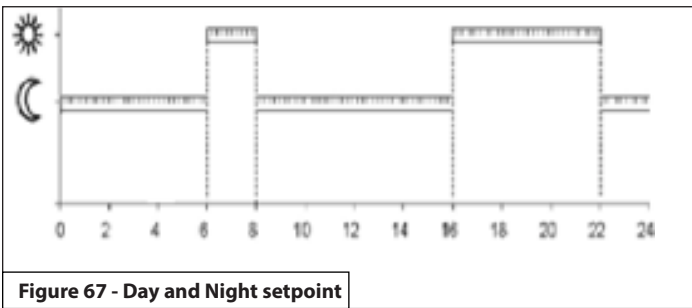

Figure 67 - Day and Night setpoint

**N. Time Programs – Heating Schedule**  
(Only applicable when using NTI room sensor)

The end user can choose from five predefined time programs to heat according to his wishes. When a time program is activated, the boiler will operate in the desired time periods to maintain the room temperature at comfort temperature level. Outside these periods, the boiler operates at a reduced temperature level.

<b>0-24h</b>	Mo-Su	00:00 – 24:00		
<b>P1 Family Program</b>	Mo-Th	06:00 – 22:00		
	Fr-Sa	06:00 – 23:00		
	Su	07:00 – 22:00		
<b>P2 Program without lunch</b>	Mo-Th	06:00 – 08:00	16:00 – 22:00	
	Fr	06:00 – 08:00	15:00 – 23:00	
	Sa	07:00 – 23:00		
	Su	08:00 – 22:00		
<b>P3 Program with lunch</b>	Mo-Th	06:00 – 08:00	11:30 – 13:00	16:00 – 22:00
	Fr	06:00 – 08:00	11:30 – 23:00	
	Sa	06:00 – 23:00		
	Su	07:00 – 22:00		
<b>6-22h</b>	Mo-Su	06:00 – 22:00		
<b>EXT</b>	<b>Time program defined by external source (app or room unit). The details can not be displayed on the boiler display.</b>			
<b>Time program defined by external source (app or room unit). The details can not be displayed on the boiler display.</b>				

Table 29 - Time programs heating

**NOTICE**

Time programs heating are active only with NTI Room Thermostat or Sensor

**O. Automatic Summer / Winter Changeover**

When this function is activated, the boiler automatically switches from “winter” mode (🔥 + 🌬️) to “summer” mode (🌬️), based on outdoor temperature conditions.

This means that the appliance can independently activate or deactivate the heating mode.

The criteria for the change are:

If the outdoor temperature is more than 1°F above the desired summer / winter switchover temperature during 5h (delay time), the boiler goes from winter to summer mode.

If the outdoor temperature is more than 1°F lower than the desired summer / winter switchover temperature during 5h (delay time), the boiler will go from summer to winter mode.

**Summer / winter changeover temperature**

External temperature criterion to switch from winter operation to summer operation, factory setting is 68 °F.

## P. Technical Menu - Access and Navigation

To access advanced setup and troubleshooting parameters, it is necessary to enter the Technical Menu. The Technical Menu includes a number of Quick Access Menus which allow easy access to commonly used parameters. See Q. Technical Menu - Menu Structure. The Quick Access Menu option, "MENU", provides access to all parameters. See R. Technical Menu - Complete Menu. Instructions on how to access and change the menus are provided below.

The various parameters can be activated and changed using the buttons shown below:

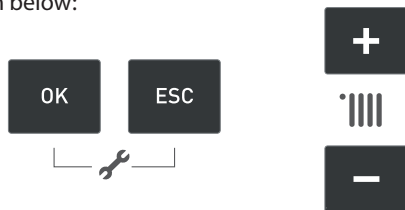

OK and ESC buttons together for 5 seconds to access the technical menu. CH + and - buttons to scroll through the menus and adjust settings. OK button to select parameters and save settings. ESC button to exit menu level / parameter without saving.

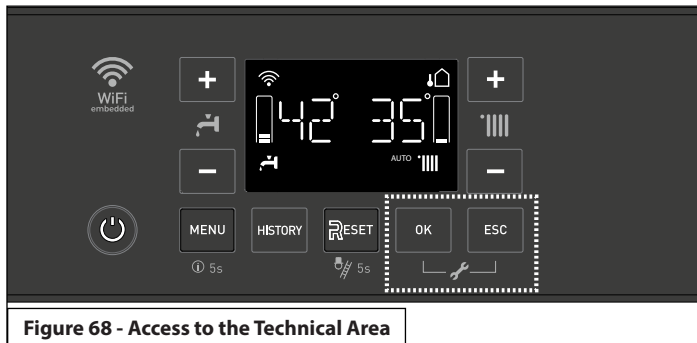

The menu and parameter numbers are shown on the display. **CAUTION!** THE MENUS RESERVED FOR QUALIFIED TECHNICIANS MAY ONLY BE ACCESSED AFTER ENTERING THE ACCESS CODE.

To access the Menus, open the cover and proceed as follows (in this example: Parameter **2.3.1**)

1. Simultaneously press the **OK** and **ESC** buttons for 5 seconds. The display shows **222**.

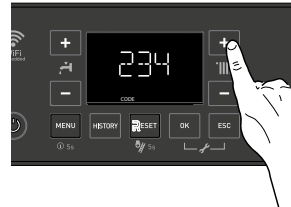

2. Press the **+** button to select **234**, the service code.

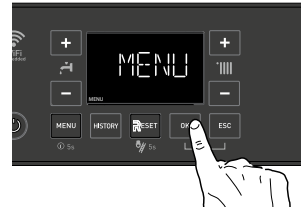

3. Press the **OK** button. The display shows **MENU**.



4. Press the **OK** button. The display shows menu **0**.



5. Press the **+** button to select menu **2**.



6. Press the **OK** button to access the menu. The display shows sub-menu **20**.



7. Press the **+** button to select the sub-menu **23**.



9. Press **OK** to access the sub-menu. The display shows the parameter **231**.

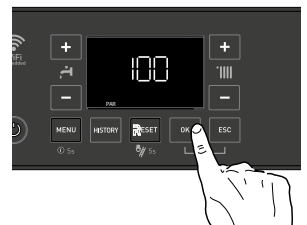

10. Press **OK** to access the parameter. The display shows the current parameter value. In this example, **100**.

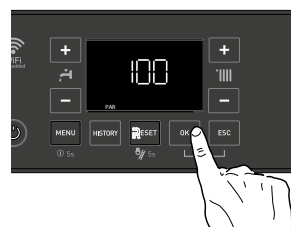

11. Press the **+** or **-** buttons to select a new value. In this example, **96**.
12. Press **OK** to save the change, or press the **ESC** button to exit without saving. In this example press OK.

After making changes, press the **ESC** button until the normal display screen is restored.



Q. Technical Menu - Menu Structure

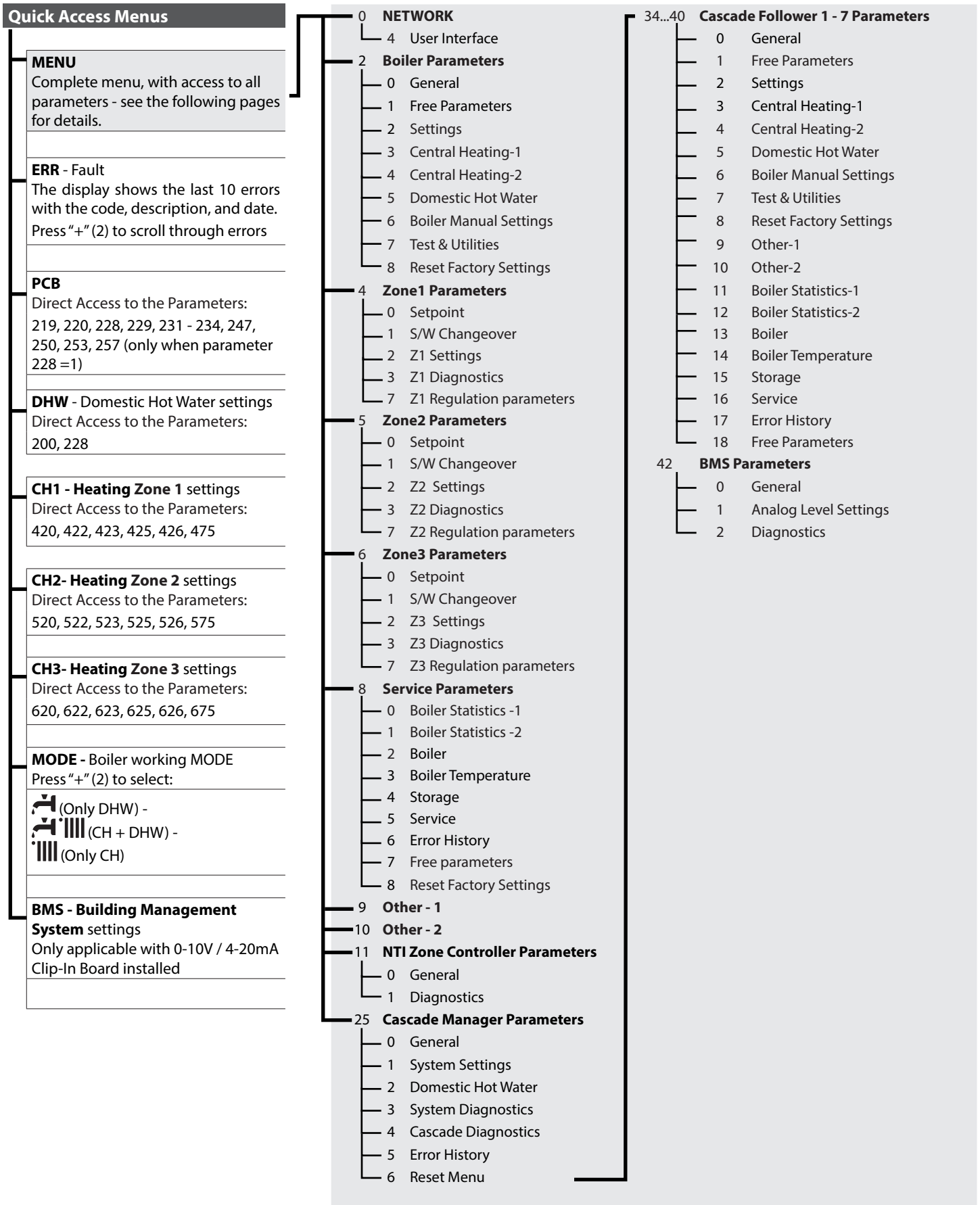

Figure 69 - Menu Structure

## Part 9 - Controls

### R. Technical Menu - Complete Menu

Menu	Sub-Menu	Parameter	Description	Value	Default Setting	
<b>ACCESS the Complete Menu</b>						
<ol style="list-style-type: none"> <li>1. Simultaneously press the the <b>OK</b> and <b>ESC</b> buttons for 5 seconds. The display shows <b>222</b>.</li> <li>2. Press the "+" button to select <b>234</b>, the service code.</li> <li>3. Press the <b>OK</b> button. Then press the "+" button until the display shows <b>MENU</b>.</li> <li>4. Press the <b>OK</b> button to enter the complete menu. See the instructions on page 68 and complete menu list below.</li> </ol>						
<b>0</b>	<b>NETWORK</b>					
<b>0</b>	<b>4</b>	<b>USER INTERFACE</b>				
<b>0</b>	<b>4</b>	<b>0</b>	Heating zone to be set from the home screen	1 = 1 Zone, 2 = 2 Zones, 3 = 3 Zones	1	
<b>0</b>	<b>4</b>	<b>1</b>	Backlight timing	1 - 10 minutes or 24 hours	10	
<b>0</b>	<b>4</b>	<b>6</b>	Cascade Boiler Configuration	UNDEF = undefined, b-SIN = single boiler, b-MAS = master boiler, b-FL1 = follower #1 boiler, b-FL2 = Follower #2, b-FL3 = Follower #3, b-FL4 = Follower #4, b-FL5 = Follower #5, b-FL6 = Follower #6, b-FL7 = Follower #7	b--SIN	Reserved for Cascade applications. See Cascade Instruction Manual for details.
<b>0</b>	<b>4</b>	<b>7</b>	Units	0 = Metric (°C), 1 = US (°F)	1	
<b>2</b>	<b>BOILER PARAMETERS</b>					
<b>2</b>	<b>0</b>	<b>GENERAL</b>				
<b>2</b>	<b>0</b>	<b>0</b>	DHW Setpoint Temperature <b>TRX COMBI</b>	97 - 140°F	125	Also settable via the home screen - see item 2 Figure 56 (not applicable when 2.2.8 = 2)
			DHW Setpoint Temperature <b>TRX non-COMBI</b>	104 - 149°F	125	
<b>2</b>	<b>0</b>	<b>1</b>	DHW Preheating	0 = Disabled, 1 = Enabled	1	Enables/disables comfort on/off setting via parameter 2.5.0.
<b>2</b>	<b>1</b>	<b>FREE PARAMETERS (DO NOT USE)</b>				
<b>2</b>	<b>1</b>	<b>1</b>	DO NOT USE			
<b>2</b>	<b>1</b>	<b>2</b>	DO NOT USE			
<b>2</b>	<b>1</b>	<b>3</b>	DO NOT USE			
<b>2</b>	<b>1</b>	<b>5</b>	DO NOT USE			
<b>2</b>	<b>1</b>	<b>6</b>	DO NOT USE			
<b>2</b>	<b>1</b>	<b>9</b>	DHW Flow Detection Device Type	0 = Flow Switch, 1 = Flow Meter	1	TRX199C uses a flow meter. Not applicable for non-Combi models.
<b>2</b>	<b>2</b>	<b>BOILER GENERAL SETTINGS</b>				
<b>2</b>	<b>2</b>	<b>0</b>	Ignition Power	0 - 100	Must be set in accordance with Table 32.	
<b>2</b>	<b>2</b>	<b>3</b>	TT2 Input Configuration	0 = Auxiliary Limit Switch, 1 = Room thermostat zone 2	1	
<b>2</b>	<b>2</b>	<b>4</b>	Automatic Temperature Control	0 = Disabled, 1 = Enabled	1	
<b>2</b>	<b>2</b>	<b>5</b>	Heating ignition delay (for new demand)	0 = Disabled, 1 = 10 seconds, 2 = 90 seconds, 3 = 210 seconds	0	
<b>2</b>	<b>2</b>	<b>8</b>	Combi Version - <b>TRX C</b> CANNOT BE MODIFIED	0 = Combi	0	
			Boiler Version - <b>TRX</b> Type of DHW control for Indirect Hot Water Heater (Tank Sensor or Aquastat)	0 = NOT USED 1 = Storage with Tank Sensor 2 = Storage with Aquastat	2	
<b>2</b>	<b>2</b>	<b>9</b>	Boiler Heating Capacity (MBH)	0 - 200		Only if the PCB is changed

Menu	Sub-Menu	Parameter	Description	Value	Default Setting	
2	3	<b>BOILER CH PARAMETERS - 1</b>				
2	3	1	Adjustable max CH power percentage	0 - 100	100	Limited by the absolute values defined by parameters 2.3.3 and 2.3.4, i.e., 0 = min power and 100 = max power.
2	3	2	Absolute Max DHW power percentage CANNOT BE MODIFIED	0 - 100		RESERVED FOR TECHNICAL ASSISTANCE Only if the gas or PCB is changed. See Table 32.
2	3	3	Absolute Min boiler power percentage CANNOT BE MODIFIED	0 - 100		
2	3	4	Absolute Max CH percentage CANNOT BE MODIFIED	0 - 100		
2	3	5	CH Anti-cycling time mode	0 = Manual, 1 = Automatic	1	
2	3	6	CH Anti-cycling Ignition Time Delay (when 2.3.5 = 0)	0 - 7 (minutes)	3	
2	3	7	Boiler Pump Post Circulation Time (After CH)	0 - 15 minutes or OC (On Continuously)	3	
2	4	<b>BOILER PARAMETER - PART 2</b>				
2	4	3	CH Fan Post-Purge	0 = 2 minutes, 1 = 5 minutes	0	
2	4	4	CH Boost Interval	0 - 60 (minutes)	16	Only applicable when the type of temperature control is set to Basic Temp. Control (Parameter 4.2.1 - 5.2.1 - 6.2.1 = 1)
			Sets the time delay between the automatic adjustments of the boiler target temperature in increments of +/- 7°F.			
2	4	7	CH Pressure Safety	1 = pressure switch at minimum	1	RESERVED FOR TECHNICAL ASSISTANCE Only if the PCB is changed
2	4	9	Outdoor Temperature Reading Correction	-5 - +5 (°F)	0	Only active with outdoor sensor connected
2	5	<b>DOMESTIC HOT WATER PARAMETER</b>				
2	5	0	DHW COMFORT function	0 = deactivated, 1 = timed, 2 = always on	0 - Combi 2 - Boiler	
			<b>TRX Non-Combi models set to 2 – Always On</b> = This is not changeable. <b>TRX Combi models set to 0 – Deactivated</b> = COMFORT function is not active. <b>TRX Combi models set to 1 or 2 – On</b> (activates conditionally once per Comfort Anti-cycling Time) = Activating the COMFORT function keeps the DHW heat exchanger temperature warm when a DHW demand is not active. This reduces the amount of time it takes for the boiler to meet a hot water demand. COMFORT will display when this function is active. <b>NOTE:</b> Parameter 251 "Comfort Anti-cycling Time", is defaulted to 60 min, and has a range [0 - 120] min.			
2	5	1	DHW Comfort Anti-cycling Time	0 - 120 (minutes)	60	
2	5	2	DHW Start Delay	5 - 200 (0.5 to 20 seconds)	5	Anti "water hammering"
2	5	3	DHW Switch Off Logic	0 = anti-scale (stop at > 144°F) 1 = + 7 °F /setting	0	
2	5	4	DHW Post Purge and Pump Cycle	0 = OFF, 1 = ON	0	OFF = 30 second post-circulation and 2 minute post-ventilation (or 3 minute post-circulation and 5 minute post-ventilation if the boiler temperature requires it) ON = When setting is ON, time for post-circulation is 3 minutes, while the time for post-ventilation is 5 minutes.
2	5	5	CH Start Delay Following DHW	0 - 30 (minutes)	0	
2	5	7	Anti-legionella Function	0 = OFF 1 = ON	0	<b>TRX Non-Combi</b> = Activated when the boiler is connected to a tank by an NTC sensor. (Parameter 228 = 1)
			This function prevents the formation of Legionnaire's disease bacteria which may develop in piping and indirect water heaters (IWH) at temperatures between 68°F and 104°F. When activated, if the IWH temperature stays below 138°F for over 100 hours, the boiler will heat the water in the IWH until it reaches 149°F for 30 minutes.			

## Part 9 - Controls

Menu	Sub-Menu	Parameter	Description	Value	Default Setting	
2	5	8	Antilegionella frequency	24 - 720 (Hours), or 30 days	30 days	TRX <b>Non-Combi</b> = Activated when the boiler is connected to a tank by an NTC sensor. (Parameter 228 = 1)
2	6	<b>BOILER MANUAL SETTINGS</b>				Only to test components
2	6	0	Manual mode activation	0 = OFF, 1 = ON	0	
2	6	1	Boiler pump control	0 = OFF, 1 = ON	0	Set Parameter 260=1
2	6	2	Fan control	0 = OFF, 1 = ON	0	Set Parameter 260=1
2	6	3	3 way valve control	0 = DHW, 1 = Heating	0	Set Parameter 260=1
2	7	<b>TEST &amp; UTILITIES</b>				
2	7	0	Test Mode	TEST+     = Max Heating power TEST+     = Max DHW power TEST+     = Minimum power.		TEST Mode can also be activated by pressing the <b>Reset</b> button for 10 seconds. Test Mode deactivates after 30 minutes or by pressing <b>Reset</b> .
2	7	1	Air-purge cycle	0 = OFF, 1 = ON		See First Ignition section.
2	7	4	Floor drying cycle	0 = OFF 1 = Functional Heating 2 = Curing Heating 3 = Functional Heating + Curing Heating 4 = Curing Heating + Functional Heating 5 = Manual	0	
2	7	5	Floor dry Supply setpoint temperature	77 - 140°F	131	
2	8	<b>RESET FACTORY SETTINGS</b>				
2	8	0	Automatically resets all parameters to the factory defaults. <b>WARNING:</b> Always check PCB settings if restoring factory default settings on a replacement controller. Replacement controllers have generic settings that may not be specific to the boiler model.	Reset: OK = yes, ESC = no		To Reset all parameter settings, press the OK button.
2	10	0	CH On Differential Temperature	0 - 36°F	11	Determines how much the boiler outlet temperature can drop below target before turning the boiler back on.
2	10	1	DHW Modulation Setpoint	68 - 179°F	179	Boiler target temperature during a DHW demand. Not applicable for Combi models.
2	10	2	DHW On Differential Temperature	0 - 36°F	0	Determines how much the DHW storage tank temperature can drop below target before initiating a DHW demand. Only applicable when 2.2.8 = 1.
2	10	3	Emergency Setpoint	68 - 179°F	113	Sets Follower boiler operating temperature when communication with the Master is lost, or when the System Sensor is disconnected. See Cascade Instruction Manual.
2	10	4	CH/DHW Shifting Priority Timer	0 - 1440 minutes	45	Determines how long a CH or DHW demand can last before the priority is switched. First priority is with DHW. A value of 0 keeps the priority with DHW indefinitely.

Menu	Sub-Menu	Parameter	Description	Value	Default Setting	
2	10	5	CH Off Differential Temperature	4 - 36°F	11	Determines how much the boiler outlet temperature can go over target before turning the burner off.
<b>4 ZONE 1 PARAMETERS</b>						
<b>4 0 ZONE 1 TEMPERATURE SETTINGS</b>						
4	0	0	Temperature Day	50 - 86 °F	66	Only applicable when using an NTI room sensor
4	0	1	Temperature Night	32 - 86 °F	61	
4	0	2	Zone Fixed Temperature	86 - 179 °F	179	Parameter 4.2.0 = 1
				68 - 122 °F	120	Parameter 4.2.0 = 0
4	0	3	Zone Freeze Protection Temperature	36 - 59 °F	41	Only applicable when using an NTI room sensor - Changes all zones
<b>4 1 SUMMER/WINTER CHANGEOVER</b>						
4	1	0	S/W function activation	0 = OFF, 1 = ON	0	
4	1	1	S/W temperature threshold	50 - 86 °F	68	
4	1	2	S/W delay time	0 - 300 minutes	60	
<b>4 2 ZONE 1 SETTINGS</b>						
4	2	0	Temperature Range	0 = 68 - 122°F (low temperature) 1 = 86 - 179°F (high temperature)	1	
4	2	1	Type of Temperature Control	0 = Fixed Outlet Temperature 1 = Basic Temp. Control 2 = Indoor Temp. Reset 3 = Outdoor Temp. Reset 4 = Indoor and Outdoor Temp. Reset	3	See Table 28 and F. Type of Temperature Control for details.
4	2	2	Slope of Outdoor Reset Curve	0.2 - 0.8 (when 4.2.0 = 0)	0.6	(low temperature)
				0.4 - 3.5 (when 4.2.0 = 1)	1.3	(high temperature)
<p>The graph illustrates the relationship between outdoor temperature and boiler outlet temperature for different slope settings. The y-axis represents the outlet temperature in degrees Fahrenheit, ranging from 32 to 194. The x-axis represents the outside temperature in degrees Fahrenheit, ranging from 77 to -13. Solid lines represent high temperature slopes, and dashed lines represent low temperature slopes. A horizontal line at 86°F is labeled 'Setpoint of the room temperature'.</p>						
						<p>The greater the slope, the quicker the target temperature rises as the outdoor temperature decreases. Applicable when 4.2.1 = 3 or 4.</p> <p>See J. Slope of Outdoor Reset Curve.</p>

## Part 9 - Controls

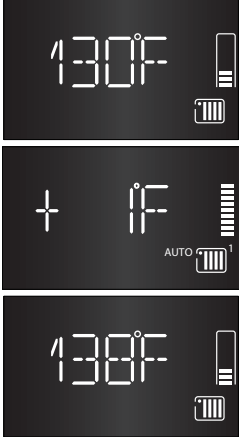
Menu	Sub-Menu	Parameter	Description	Value	Default Setting	
4	2	3	Parallel Shift of Reset Curve	-12 - +12 (when 4.2.0 = 0) -25 - +25 (when 4.2.0 = 1)	0	See K. Parallel Shift of Reset Curve.
			<p>When the Reset Curve results in a boiler target temperature that is too high or too low (i.e., heats the building too quickly or slowly), Parallel Shift can be used to offset the curve up or down to increase or decrease the boiler target temperature.</p> <p><b>NOTE:</b> Adjusting Parallel Shift is only possible when Auto Boost is OFF (4.7.5 = 0).</p> <p>The Parallel Shift can be adjusted from the home screen using the CH + and - buttons (Figure 56, Item 8).</p> <p>With the first press of the CH + or - button, the display shows the current CH target temperature (e.g., 130°F).</p> <p>After a 3-5 second delay, the display begins flashing the current offset (Parallel Shift) setting. Subsequent CH + or - button presses adjusts the offset up or down.</p> <p>After a few seconds the display shows the new CH target temperature (e.g., 138°F), then returns to the home screen.</p>			
4	2	4	Room Sensor Influence	0 - 20	2	if Parameter 4.2.0 = 0
			<p>Adjusts the influence of room temperature on target boiler temperature - a higher setting causes a greater increase to the boiler target temperature as the indoor temperature drops below room setpoint. <b>Only applicable when using an optional NTI Room Sensor and when 4.2.1 = 2 or 4.</b></p>	4	if Parameter 4.2.0 = 1	
4	2	5	MAXIMUM Temperature Setting	86 - 179 °F 68 - 122 °F	179	if Parameter 4.2.0 = 1
			4.2.5 sets the allowable boiler operating temperature range for Zone 1 heating, limiting Automatic Temperature Control and manual adjustments from the User Menu.	120	if Parameter 4.2.0 = 0	
4	2	6	MINIMUM Temperature Setting	86 - 179 °F 68 - 122 °F	120	if Parameter 4.2.0 = 1
			4.2.6 sets the allowable boiler operating temperature range for Zone 1 heating, limiting Automatic Temperature Control and manual adjustments from the User Menu.	80	if Parameter 4.2.0 = 0	
4	3	<b>ZONE 1 DIAGNOSTICS</b>				
4	3	0	Room Temperature	Read only		Only applicable when using an NTI room sensor
4	3	1	Room Temperature Setpoint	Read only		
4	3	4	Heat Call	0 = OFF, 1 = ON (Read only)		
4	7	<b>ZONE 1 REGULATION PARAMETERS</b>				
4	7	5	Auto Boost	0 = OFF, 1 = ON	0	See L. Auto Boost.
5	<b>ZONE 2 PARAMETERS</b>					
5	0	<b>ZONE 2 TEMPERATURE SETTINGS</b>				
5	0	0	Temperature Day	50 - 86 °F	66	Only applicable when using an NTI room sensor
5	0	1	Temperature Night	32 - 86 °F	61	
5	0	2	Fixed Temperature	86 - 179 °F	179	Parameter 5.2.0 = 1
				68 - 122 °F	120	Parameter 5.2.0 = 0
5	0	3	Zone Freeze Protection Temperature	36 - 59 °F	41	Only applicable when using an NTI room sensor - Changes all zones
5	1	<b>SUMMER/WINTER CHANGEOVER</b>				
5	1	0	S/W function activation	0 = OFF, 1 = ON	0	
5	1	1	S/W temperature threshold	50 - 86 °F	68	
5	1	2	S/W delay time	0 - 300 minutes	60	
5	2	<b>ZONE 2 SETTINGS</b>				
5	2	0	Temperature Range	0 = 68 - 122°F (low temperature) 1 = 86 - 179°F (high temperature)	1	



Menu	Sub-Menu	Parameter	Description	Value	Default Setting	
5	2	1	Type of Temperature Control	0 = Fixed Outlet Temperature 1 = Basic Temp. Control 2 = Indoor Temp. Reset 3 = Outdoor Temp. Reset 4 = Indoor and Outdoor Temp. Reset	3	See Table 28 and F. Type of Temperature Control for details.
5	2	2	Slope of Outdoor Reset Curve  See graph and description of Parameter 422.	0.2 - 0.8	0.6	(low temperature)
				0.4 - 3.5	1.3	(high temperature)
5	2	3	Parallel Shift of Reset Curve  See description of Parameter 423.	-12 - +12 (when 4.2.0 = 0)	0	
				-25 - +25 (when 4.2.0 = 1)		
5	2	4	Room Sensor Influence	0 - 20	2	if Parameter 4.2.0 = 0
			Adjusts the influence of room temperature on target boiler temperature - a higher setting causes a greater increase to the boiler target temperature as the indoor temperature drops below room setpoint. <b>Only applicable when using an optional NTI Room Sensor and when 5.2.1 = 2 or 4.</b>		4	if Parameter 4.2.0 = 1
5	2	5	MAXIMUM temperature setting	86 - 179 °F	179	if parameter 5.2.0 = 1
			5.2.5 sets the allowable boiler operating temperature range for Zone 2 heating, limiting Automatic Temperature Control and manual adjustments from the User Menu.	68 - 122 °F	120	if parameter 5.2.0 = 0
5	2	6	MINIMUM temperature setting	86 - 179 °F	120	if parameter 5.2.0 = 1
			5.2.6 sets the allowable boiler operating temperature range for Zone 2 heating, limiting Automatic Temperature Control and manual adjustments from the User Menu.	68 - 122 °F	80	if parameter 5.2.0 = 0
5	3	<b>ZONE 2 DIAGNOSTICS</b>				
5	3	0	Room Temperature	Read only		Only applicable when using an NTI room sensor
5	3	1	Room Temperature Setpoint	Read only		
5	3	4	Heat Call	0 = OFF, 1 = ON (Read only)		
5	7	<b>ZONE 2 REGULATION PARAMETERS</b>				
5	7	5	Auto Boost	0 = OFF, 1 = ON	0	See description of Parameter 475.
6	<b>ZONE 3 PARAMETERS</b>					
6	0	<b>ZONE 3 TEMPERATURE SETTINGS</b>				
6	0	0	Temperature Day	50 - 86 °F	66	Only applicable when using an NTI room sensor
6	0	1	Temperature Night	32 - 86 °F	61	
6	0	2	Fixed Temperature	86 - 179 °F	179	Parameter 6.2.0 = 1
				68 - 122 °F	120	Parameter 6.2.0 = 0
6	0	3	Zone Freeze Protection Temperature	36 - 59 °F	41	Only applicable when using an NTI room sensor - Changes all zones
6	1	<b>SUMMER/WINTER CHANGEOVER</b>				
6	1	0	S/W function activation	0 = OFF, 1 = ON	1	
6	1	1	S/W temperature threshold	50 - 86 °F	68	
6	1	2	S/W delay time	0 - 300 minutes	60	
6	2	<b>ZONE 3 SETTINGS</b>				
6	2	0	Temperature Range	0 = 68 - 122°F (low temperature) 1 = 86 - 179°F (high temperature)	1	
6	2	1	Type of Temperature Control	0 = Fixed Outlet Temperature 1 = Basic Temp. Control 2 = Indoor Temp. Reset 3 = Outdoor Temp. Reset 4 = Indoor and Outdoor Temp. Reset	3	See Table 28 and F. Type of Temperature Control for details.

## Part 9 - Controls

Menu	Sub-Menu	Parameter	Description	Value	Default Setting	
6	2	2	Slope of Outdoor Reset Curve	0.2 - 0.8	0.6	(low temperature)
				0.4 - 3.5	1.3	(high temperature)
See graph and description of Parameter 422.						
6	2	3	Parallel Shift of Reset Curve	-12 - +12 (when 4.2.0 = 0)	0	
				-25 - +25 (when 4.2.0 = 1)		
See description of Parameter 423.						
6	2	4	Room Sensor Influence	0 - 20	2	if Parameter 4.2.0 = 0
					4	if Parameter 4.2.0 = 1
Adjusts the influence of room temperature on target boiler temperature - a higher setting causes a greater increase to the boiler target temperature as the indoor temperature drops below room setpoint. <b>Only applicable when using an optional NTI Room Sensor and when 6.2.1 = 2 or 4.</b>						
6	2	5	MAXIMUM temperature setting	86 - 179 °F	179	if Parameter 6.2.0 = 1
				68 - 122 °F	120	if Parameter 6.2.0 = 0
6.2.5 sets the allowable boiler operating temperature range for Zone 3 heating, limiting Automatic Temperature Control and manual adjustments from the User Menu.						
6	2	6	MINIMUM temperature setting	86 - 179 °F	120	if Parameter 6.2.0 = 1
				68 - 122 °F	80	if Parameter 6.2.0 = 0
6.2.6 sets the allowable boiler operating temperature range for Zone 3 heating, limiting Automatic Temperature Control and manual adjustments from the User Menu.						
6	3	<b>DIAGNOSTICS</b>				
6	3	0	S/W function activation	0 = OFF, 1 = ON	0	Only applicable when using an NTI room sensor
6	3	1	S/W temperature threshold	50 - 86 °F	68	
6	3	4	S/W delay time	0 - 300 minutes	60	
6	7	<b>ZONE 3 REGULATION PARAMETERS</b>				
6	7	5	Auto Boost	0 = OFF, 1 = ON	0	See description of Parameter 475.
8	<b>SERVICE PARAMETERS</b>					
8	0	<b>BOILER STATISTICS-1 - Read Only</b>				
8	0	0	3 way valve cycles No. (n x10)			
8	0	1	Boiler Pump On Hours (h x10)			
8	0	2	Boiler pump cycles No. (n x10)			
8	0	3	Boiler Power On Time (h x10)			
8	0	4	Fan On Hours (h x10)			
8	0	5	Number of fan cycles (n x10)			
8	0	6	CH number of flame detections (n x10)			
8	0	7	DHW number of flame detections (n x10)			
8	1	<b>BOILER STATISTICS-2 - Read Only</b>				
8	1	0	CH Burner On Hours (h x10)			
8	1	1	DHW Burner On Hours (h x10)			
8	1	2	Number Of Flame Faults (n x10)			
8	1	3	Number Of Ignition Cycles (n x10)			
8	1	4	Average CH Cycle Length (min)			
8	1	6	Number of times the Priority Timer (2.10.4) has elapsed, switching priority from DHW to CH (or vice versa).			
8	2	<b>BOILER CURRENT STATUS - Read Only</b>				
8	2	1	Fan Status	0 = OFF, 1 = ON		
8	2	2	Fan Speed RPM			
8	2	3	Boiler Pump Status	0 = OFF, 1 or 2 = ON		
8	2	4	3 Way Valve Position	0 = DHW, 1 = Central Heating		
8	2	5	DHW Flow Rate (in US gpm)			Not applicable to Non-Combi models
8	2	6	APS Status	0 = Open, 1 = Closed		
8	2	8	Gas Power (kW)			
8	3	<b>BOILER CURRENT TEMPERATURES - Read Only</b>				
8	3	0	CH Supply Setpoint (in °F)			

Menu	Sub-Menu	Parameter	Description	Value	Default Setting		
8	3	1	CH Supply Temperature (in °F)				
8	3	2	CH Return Temperature (in °F)				
8	3	3	DHW Outlet Temperature (in °F)			Not applicable to Non-Combi models	
8	3	4	Exhaust Flue Temperature (in °F)				
8	3	5	Outdoor Temperature (in °F)			Only with outdoor sensor connected	
8	4	<b>DHW TANK TEMPERATURE (ONLY ACTIVE WITH CONNECTED NTC TANK SENSOR) - Read Only</b>					
8	4	0	Displays current tank temperature (in °F)			Only with NTC tank sensor connected	
8	5	<b>SERVICE</b>					
8	5	0	Months to next maintenance	0 - 60 (months)	12		
			If enabled (8.5.1 = 1), a notification is made on the display (and via the Tele-diagnostic Service, if applicable), warning that it is time for maintenance				
8	5	1	Enable Maintenance advice	0 = OFF, 1 = ON	0		
8	5	2	Maintenance Warning Reset	Reset? OK= Yes, Esc = No			
			Resets Maintenance Advice and clears the Warning.				
8	5	4	SW Version - Display Interface				
8	5	5	SW Version - Main Controller				
8	6	<b>ERROR HISTORY</b>					
8	6	0	10 last errors	ERROR 0 - ERROR 9			
			This parameter displays the last 10 boiler errors, indicating the error code, day, month and year of occurrence. When the parameter is accessed, the errors are listed from ERROR 0 to ERROR 9.				
8	6	1	Error list reset - Clears Error History	Reset? OK = yes, ESC = no			
8	7	<b>FREE PARAMETERS - Read Only</b>					
8	7	0	NOT USED				
8	7	1	NOT USED				
8	7	2	NOT USED				
8	7	3	NOT USED				
8	7	4	Boiler flow switch	0= OFF, 1= ON			
8	7	6	Safety flame sensor	0= OFF, 1= ON			
8	7	8	Boiler power level (%)	0 - 100 (0 = minimum power, 100 = maximum power)			
8	7	9	Boiler Flame Signal Measured by the Control	The flame signal must exceed 18 to initially detect the presence of flame. Flame loss is detected if the signal drops below 15.			

Table 30 - Complete Parameters List

### WARNING

Thoroughly clean and flush any system that has used glycol before installing the boiler. Provide the customer with a material safety data sheet (MSDS) on the fluid used.

#### A. Check / Control Water Chemistry

### CAUTION

Chemical imbalance of the water supply may affect efficiency and cause severe damage to the appliance and associated equipment. It is important that the water chemistry on both the domestic hot water and central heating sides are checked before installing the appliance. Water quality must be professionally analyzed to determine whether it is necessary to treat the water. Various solutions are available to adjust water quality. Adverse water quality will affect the reliability of the system. In addition, operating temperatures above 135oF will accelerate the build-up of lime scale and possibly shorten appliance service life. Failure of an appliance due to lime scale build-up, low pH, or other chemical imbalance IS NOT covered by the warranty.

To ensure extended service life, it is recommended to test water quality prior to installation. Listed below are some guidelines.

### CAUTION

Do not use petroleum-based cleaning or sealing compounds in the boiler system. Damage to elastomer seals and gaskets in the system could occur, resulting in substantial property damage.

The water must be potable, free of corrosive chemicals, sand, dirt, and other contaminants. It is up to the installer to ensure the water does not contain corrosive chemicals or elements that can damage the heat exchanger. Potable water is defined as drinkable water supplied from utility or well water in compliance with EPA secondary maximum contaminant levels (40 CFR Part 143.3). If the water contains contaminants higher than outlined by the EPA, water treatment is recommended and additional, more frequent maintenance may be required. See Table 1.

If you suspect that your water is contaminated in any way, discontinue use of the appliance and contact an authorized technician or licensed professional.

#### Clean system to remove sediment\*

1. You must thoroughly flush the system (without boiler connected) to remove sediment. The high-efficiency heat exchanger can be damaged by buildup or corrosion due to sediment.
2. For zoned systems, flush each zone separately through a purge valve. (If purge valves and isolation valves are not already installed, install them to properly clean the system.)
3. Check the return Y strainer (if installed). Remove and clean sediment and debris if necessary.
4. Flush system until water runs clean and you are sure piping is free of sediment.

**\*NOTE: Boiler failure due to improper water chemistry is not covered by warranty.**

**NOTE: Combi Models:** It is recommended to clean the DHW side of the heat exchanger at least once a year to prevent lime scale buildup. Follow the maintenance procedure to clean the heat exchanger in the Maintenance Section of this manual.

#### B. Check for Gas Leaks

### WARNING

Before starting the boiler, and during initial operation, smell near the floor and around the boiler for gas odorant or any unusual odor. Remove boiler front door and smell interior of boiler enclosure. Do not proceed with startup if there is any indication of a gas leak. Repair any leaks at once.

**PROPANE BOILERS ONLY** – The propane supplier mixes an odorant with the propane to make its presence detectable. In some instances the odorant can fade, and the gas may no longer have an odor. Before startup (and periodically thereafter), have the propane supplier verify the correct odorant level in the gas.

If you discover any evidence of a gas leak shut down the boiler at once. Find the leak source with a bubble test and repair immediately. Do not start the appliance again until the leak is repaired. Failure to comply could result in substantial property damage, severe personal injury, or death.

#### C. Freeze Protection (When Used)

### WARNING

NEVER use automotive or standard glycol antifreeze. Do not use ethylene glycol made for hydronic systems. Use only freeze-protection fluids certified by fluid manufacturer as suitable for use with stainless steel boilers, verified in the fluid manufacturer's literature. Thoroughly clean and flush any system that has used glycol before installing the new boiler. Provide the boiler owner with a material safety data sheet (MSDS) on the fluid used.

#### NOTE: Loops Serving Indirect Water Heaters (IWHs)

Glycol used in IWH loops should be food grade propylene glycol, FDA rated as "generally recognized as safe" (GRAS). If using a glycol / potable water mix, the water chemistry must meet the requirements in this manual. The glycol content of the liquid must not exceed 50%, unless the manufacturer specifies a different ratio. Glycol should be checked periodically to prevent it from becoming acidic. Please refer to guidelines provided by the glycol manufacturer regarding glycol maintenance.

**NOTE:** Glycol not recognized as GRAS may only be used in closed loop CH applications.

1. Determine the freeze protection fluid quantity using total system water content following the fluid manufacturer's instructions. Remember to include expansion tank water content.
2. Local codes may require back flow preventer or actual disconnect from city water supply.
3. When using freeze protection fluid with automatic fill, install a water meter to monitor water makeup. Freeze protection fluid may leak before the water begins to leak, causing concentration to drop, reducing the freeze protection level.
4. Glycol in hydronic applications should include inhibitors that prevent the glycol from attacking metallic system components. Make certain that the system fluid is checked for the correct glycol concentration and inhibitor level.
5. The glycol solution should be tested at least once a year or as recommended by the glycol manufacturer.

- Anti-freeze solutions expand more than water. For example: A 50% by volume solution expands 4.8% in volume for a temperature increase from 32 - 80°F, while water expands 3% over the same temperature rise. Allowances must be made in system design for expansion.
- A 30% mixture of glycol will result in a BTU output loss of 15% with a 5% increase in head against the system circulator.
- A 50% mixture of glycol will result in a BTU output loss of 30% with a 50% increase in head against the system circulator.

**NOTE:** BTU losses apply to both CH and DHW.

### CAUTION

It is highly recommended to carefully follow the glycol manufacturer's recommended concentrations, expansion requirements, and maintenance recommendations (pH additive breakdown, inhibitor reduction, etc.) You must carefully calculate the additional friction loss in the system as well as the reduction in heat transfer coefficients.

#### D. System Water Fill, Purge, and Test

### ! WARNING

Ensure the boiler is full of water before firing the burner. Failure to do so will damage the boiler. Such damage IS NOT covered by warranty, and could result in property damage, severe personal injury, or death.

### CAUTION

Connect the condensate discharge pipe before filling and purging the heating circuit.

It is important to purge the system of air to avoid damage to the boiler.

The boiler and heating system must be thoroughly purged of air during the initial installation or system maintenance. Proceed as follows to purge the boiler and heating system:

- An automatic air purge valve has been provided inside the boiler to aid the purging process.
- Gradually open the main water valve until water flows. Do not open fully.
- Thoroughly purge each zone starting with the lowest point and close them only when clear water free of air is visible.
- Continue filling the system until at least 12 psi registers on the pressure gauge.

### ! WARNING

Eliminate all system leaks. Continual fresh make-up water will reduce boiler life. Minerals can build up in the heat exchanger, reducing heat transfer, overheating the heat exchanger and causing heat exchanger failure.

#### E. Purge Air from DHW System

- Make sure the CH and DHW lines are open and full of water. Turn on all electric power to boiler.

### ! WARNING

Ensure the boiler is full of water before firing the burner. Failure to do so will damage the boiler. Such damage IS NOT covered by warranty, and could result in property damage, severe personal injury, or death.

- Open hot water faucets in the DHW system. Start with the faucets nearest the boiler.
- Keep faucets open until water runs freely and all air is purged. Then move on to faucets further away from the boiler in the system.
- When water flows freely from all hot water faucets, DHW purging is complete.

#### F. Check Thermostat Circuit(s)

- Disconnect the two external wires connected to the boiler thermostat terminals TT1/TT2 (low voltage terminal strip).
- Connect a voltmeter across these two incoming wires with power supplied to the thermostat circuits. Close each thermostat, zone valve and relay in the external circuit one at a time and check the voltmeter reading across the incoming wires.
- There should NEVER be a voltage reading.
- If a voltage reading does occur under any condition, check and correct the external wiring. (This is a common problem when using 3-wire zone valves.)
- Once the external thermostat circuit wiring is checked and corrected if necessary, reconnect the external thermostat circuit wires to the boiler low voltage terminal strip. Allow the boiler to cycle.

#### G. Condensate Removal

- The boiler is a high efficiency condensing appliance. Therefore, the unit has a condensate drain. Condensate fluid is nothing more than water vapor, derived from combustion products, similar to that produced by an automobile when it is initially started. Condensation is slightly acidic (typically with a pH of 3 to 5) and must be piped with the correct materials. Never pipe the condensate using steel, copper, brass or other materials that will be subject to corrosion. Plastic PVC or CPVC pipe are the only approved materials. A condensate neutralizer, if required by local authorities, can be made up of lime crystals, marble or phosphate chips that will neutralize the condensate.
- The boiler is equipped with a barbed outlet fitting, to which the supplied hose must be installed and routed to a local drain. It is very important that the condensate line is sloped downward away from the boiler to a suitable indoor drain.

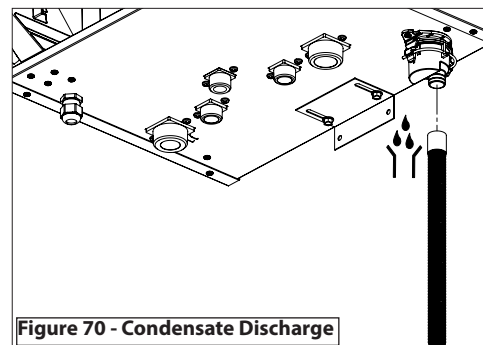

Figure 70 - Condensate Discharge

If the condensate outlet on the boiler is lower than the drain, you must use a condensate removal pump. This pump is equipped with two leads that can be connected to an alarm or another type of warning device to alert the user of a condensate overflow, which, if not corrected, could cause property damage.

## Part 10 - Start-Up Preparation

3. If a long horizontal run is used, it may be necessary to create a vent in the horizontal run to prevent a vacuum lock in the condensate line.
4. Do not expose the condensate to freezing temperatures.
5. It is very important you support the condensation line to assure proper drainage.



## ! WARNING

### FOR YOUR OWN SAFETY READ BEFORE OPERATING

1. This boiler does not have a pilot. It is equipped with an ignition device which automatically lights the burner. Do not try to light the burner by hand.

2. BEFORE OPERATING: Smell all around the boiler area for gas. Be sure to smell next to the floor because some gas is heavier than air and will settle on the floor.

#### 3. WHAT TO DO IF YOU SMELL GAS

- Do not try to light any boiler.
- Do not touch any electric switch, do not use any phone in your building.
- Immediately call your gas supplier from a neighbor's phone. Follow the gas suppliers' instructions.
- If you cannot reach your gas supplier, call the fire department.
- Turn off the gas shutoff valve (located outside the boiler) so that the handle is crosswise to the gas pipe. If the handle will not turn by hand, don't try to force or repair it, call a qualified service technician. Force or attempted repair may result in a fire or explosion.

4. Do not use this boiler if any part has been under water. Immediately call a qualified service technician to inspect the boiler and to replace any part of the control system and any gas control that has been damaged.

5. The boiler shall be installed so the gas ignition system components are protected from water (dripping, spraying, rain, etc.) during boiler operation and service (circulator replacement, condensate trap, control replacement, etc.)

Failure to follow these instructions could result in property damage, serious personal injury, or death.

If you discover any evidence of a gas leak, shut down the boiler at once. Find the leak source with a bubble test and repair immediately. Do not start the boiler again until the leak is repaired. Failure to comply could result in substantial property damage, severe personal injury, or death.

gauge. If not, repeat the procedure.

d. The purge function can be accessed at any time by pressing ESC for five (5) seconds. Press ESC to exit.

**NOTE:** It is recommended to run through the full initial purge cycle at install. Do not cut the purge cycle short.

**5.** The exhaust vent piping for combustion products should be suitable and free from any obstructions.

**6.** Any necessary ventilation inlets in the room should be open (**power vent** installation).

**7.** Set the room thermostat to the highest setting to start the boiler and test Lockout Error 501.

**NOTE:** The boiler will display a **Lockout Error 501** after the 3rd consecutive failed ignition attempt.

- The combustion fan will pre-purge for a short time before activating the igniter.

- Ensure the combustion fan post-purges for at least 5 seconds before reactivating the igniter.

- After the boiler displays Error 501, set the room thermostat to the normal setting to start the boiler.

**8.** Open the gas valve and check the connection seals, including the boiler connection seals. Check for and eliminate any leaks.

**9.** Press the RESET button to clear Error 501. The display will show **OK**.

**10.** Start the boiler by selecting CH or DHW operation.

**11. Proceed with Combustion Checking Procedure.**

### A. First Ignition

1. Make sure that the gas valve is closed and the electrical connections have been properly wired and grounded.

2. Ensure that the system pressure is at least 12 psi on the tridicator and no hot water or heating requests will be made.

**NOTE:** It is recommended to fill and purge the entire system before powering the boiler.

3. Power on the boiler (press the ON/OFF button).

4. **The boiler air purge function starts automatically.** This seven (7) minute cycle removes excess air from the CH and DHW systems.



a. During the cycle open the manual air vent within the boiler (if applicable). Close the air vent when clear water free of air is visible (after purging).

b. As air is purged boiler pressure may drop. The boiler needs to maintain at least 12-15 psi for proper purging.

**NOTE:** The water pressure switch safety is set at 8 psi to protect the boiler. Error 108 will occur if boiler pressure drops too low. After pressure is restored Error 108 will clear and the boiler will return to the purge function for another 7 minutes.

c. After the cycle has ended ensure the system is completely purged of air and verify that system pressure is at least 12 psi on the pressure

## Part 11 - Start-Up

### B. Combustion Checking Procedure

The order of operations for this procedure must always be respected.

#### Operation 1 - Gas inlet pressure check

Loosen screw 1 (Torx 10 - Line Pressure Test Port) and connect a manometer to the port using applicable tubing.

Ensure the boiler is powered on. Then enable Test Mode by pressing the RESET button for 10 seconds. The display will show TEST and the icon .

The gas line pressure must remain within the range provided in Table 22 for the gas type during all operating conditions. Upon completion of the combustion analysis and adjustment (Operations 2 through 5), remove the pressure gauge and tighten screw 1. Verify and repair any gas leaks.

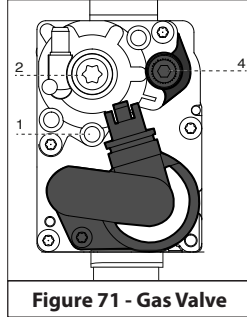

Figure 71 - Gas Valve

#### Operation 2 - Combustion Analysis

Remove the combustion test port plug as illustrated, and insert a calibrated combustion analyzer.

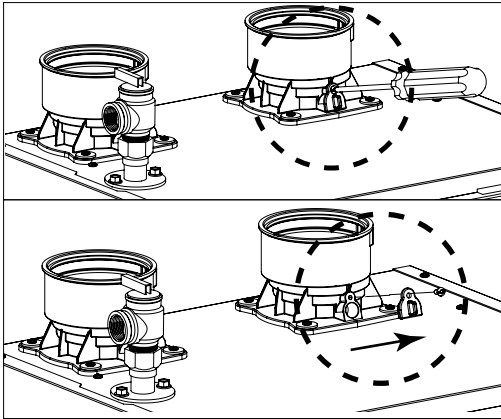

Figure 72 - Combustion Test Port

### ! WARNING

Make sure the calibrated combustion analyzer is set to the appropriate gas type. Failure to do so could result in serious personal injury or death.

It is required to use a calibrated combustion analyzer to verify final adjustment according to the combustion chart (Table 32). Failure to do so could result in serious personal injury or death.

It is very important that the combustion system be set within the recommended CO measurements listed in Table 32. Visually looking at the burner does not determine combustion quality. Failure to measure combustion with a calibrated combustion analyzer and set the throttle within the recommended CO measurements could result in property damage, severe personal injury, or death.

#### Operation 3 - Adjusting the CO<sub>2</sub> at Maximum Gas Flow Rate (High Fan Speed)



Set the thermostat at the highest possible setting or draw off the domestic hot water at the maximum water flow rate to create a demand for heat. **Note:** For only Heating Boiler Applications, open all thermostatic valves present in the CH circuit.

Select the TEST Function by pressing and holding the RESET button for 10 seconds.

**WARNING! When the Test Function is activated the temperature of the water coming out of the boiler may be more than 150°F.**

TEST and the  icon will appear on the display when Test Function is active. The boiler will operate at maximum heating power.



Press the  button to operate the boiler at the maximum power. The  icon will display.

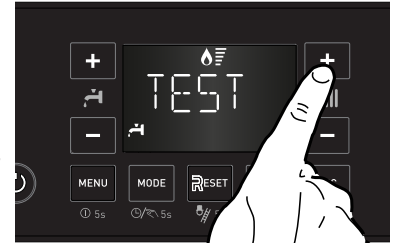

Wait 1 minute for the boiler to stabilize before carrying out the combustion analyses. Read the CO<sub>2</sub> value (%) and compare it with the values given in the table below:

Fan Speed	Natural Gas		LP Gas	
	Low	High	Low	High
CO PPM	≤175		≤175	
CO <sub>2</sub> (%)	8.5 - 9.7		9.5 - 10.7	

The CO<sub>2</sub> at minimum gas flow rate (Low Fan Speed) must be set lower than the CO<sub>2</sub> reading at maximum gas flow rate (High Fan Speed) by 0.5 to 1.0%.

For Example: If CO<sub>2</sub> at High = 9.2%, then CO<sub>2</sub> at Low must = 8.7% - 8.2%

Table 31 - Combustion Settings

**ATTENTION!! Obtain all values with the front cover installed.**

If the CO<sub>2</sub> (%) reading differs from the values given in the table, adjust the gas valve following the instructions below. Otherwise move directly to Operation 4.

#### Adjusting the Gas Valve at Maximum Gas Flow

Adjust the gas valve by turning setting screw 4 clockwise to increase the CO<sub>2</sub> level; counterclockwise to reduce the CO<sub>2</sub> level (1 turn adjusts the CO<sub>2</sub> level by approximately 0.3%). Wait 1 minute after each change in setting for the CO<sub>2</sub> value to stabilize.

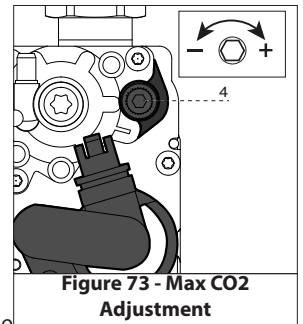



Figure 73 - Max CO<sub>2</sub> Adjustment

If the value measured corresponds to the value given in the Table 32, max adjustment is complete. Otherwise continue the setting procedure.

**ATTENTION!!** The Test Function will automatically deactivate after 30 minutes, or Test Function can be turned off manually by pressing the RESET button.

**⚠ WARNING**

**Breathing Hazard - Carbon Monoxide Gas**





- Do not operate heater if flood damaged.
- Install vent system in accordance with local codes and manufacturers installation instructions.
- Do not obstruct heater air intake or exhaust. Support all vent piping per manufacturers installation instructions.
- Do not place chemical vapor emitting products near unit.
- According to NFPA 720, carbon monoxide detectors should be installed outside each sleeping area.
- Never operate the heater unless it is vented to the outdoors.
- Analyze the entire vent system to make sure that condensate will not become trapped in a section of vent pipe and therefore reduce the open cross sectional area of the vent.

**Breathing carbon monoxide can cause brain damage or death. Always read and understand instruction manual.**

LP-304

#### Operation 4 - Checking the CO<sub>2</sub> at Minimum Gas Flow (Low Fan Speed)

With the Test Function active, press the  button to operate the boiler at minimum DHW power. The  and  icons will display.

Wait 1 minute for the boiler to stabilize before carrying out the combustion analyses.

If the CO<sub>2</sub> (%) reading at min gas flow is greater than the CO<sub>2</sub> (%) reading at max flow, or if it is less than the reading at max flow by more than 0.3%, adjust the gas valve following the instructions below. Otherwise move directly to Operation 5.

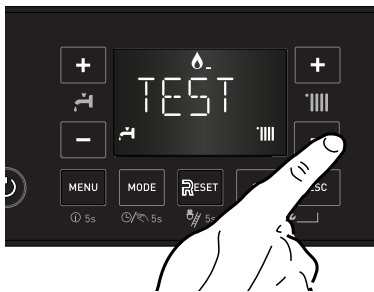

#### Adjusting the Gas Valve at Minimum Gas Flow

Remove cap and adjust screw **2** by turning counter-clockwise to reduce the CO<sub>2</sub> level; clockwise to increase the CO<sub>2</sub> level. Wait 1 minute after each adjustment for the CO<sub>2</sub> value to stabilize.

**WARNING! Minimum Gas Flow Adjustment is very sensitive.**

If the value measured corresponds to the value given in Table 32 adjustment is complete. Otherwise continue the setting procedure.

**Attention!! If the value of the CO<sub>2</sub> at minimum power has been changed, it is necessary repeat the adjusting at maximum gas flow.**

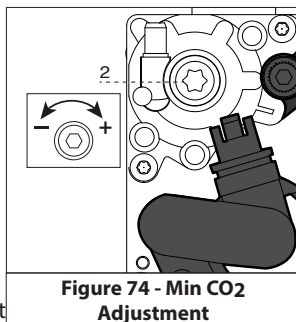

#### Operation 5 - Ending Adjustment

1. Exit Test Mode by pressing RESET.
2. Turn down the thermostat and / or stop the DHW draw-off. For Only Heating Boiler applications reset all thermostatic valves.
3. Check for and repair any leaks of gas.
4. Reinstall the front cover.
5. Reinstall the combustion test port - see Figure 72.

## Part 11 - Start-Up

TRX Models	Parameter	150		199 / 199C	
		Natural	Propane	Natural	Propane
Inlet Gas Pressure Nominal (Inches WC)		7	11	7	11
Inlet Gas Pressure Min/Max (Inches WC)		3.5 - 10.5	8 - 13	3.5 - 10.5	8 - 13
Ignition Power	220	40		65	
Maximum CH Power Adjustable (%)	231	100		100	
Minimum Power (%)	233	5		6	
Max Power (%)	232 & 234	95		97	
Gas Diaphragm (Ø) mm		none	5.7	none	5.7
Gas Input (MBH)	Max	150		197	
	Min	15		19.7	

Table 32 - Table Summarizing Powers

### C. Checking Combustion Parameters

Menu 2. - Boiler Parameters

Submenu 3. - Parameter 1 Maximum Heating Power Adjustment

Submenu 2. - Parameter 0 Ignition Power

Submenu 3. - Parameter 5 Heating Ignition Delay

#### Maximum Heating Power Adjustment 2.3.1

The maximum heating power can be adjusted to between the maximum and minimum power allowed by the boiler.

The display shows the heating power value between 100% ("100" on the display) and 0% ("0") of this interval.

To check the maximum heating power, access menu 2/sub menu 3/parameter1 (231) - see page 60.

Check the value. If necessary, modify it as indicated in Table 32.

#### Checking Ignition Power 2.2.0

To check the Ignition power access menu 2/sub menu 2/parameter 0 (220) - see page 60.

If necessary, modify it as indicated in Table 32.

#### Heating Ignition Delay Adjustment 2.3.5

This parameter is used to manually (0) or automatically (1) set the heating ignition delay time. This is the time the boiler delays igniting the burner after it has met the central heating mode setpoint and switched off.

To change this parameter, access menu 2/sub menu 3/parameter 5 (2.3.5) - see page 60.

After selecting manual, access the successive parameter 2.3.6 to set the delay between 0 and 7 minutes.

Automatic selection means that the boiler will establish the delay time based on the set-point temperature.

### D. Converting the Appliance from Natural Gas to Propane Operation

NTI boilers are factory set to operate on Natural Gas. BEFORE OPERATING ON PROPANE the boiler must be converted to Propane using the included conversion kit specific to the boiler model.

#### ! WARNING

These instructions CANNOT be used to convert NTI appliance models not referenced within these instructions. Contact NTI for the availability of conversion kits and instructions for other models.

Failure to apply these instructions properly may result in dangerous Carbon Monoxide levels, fire, or explosion, leading to property damage, serious personal injury, or death.

**ATTENTION:**

**LIQUEFIED PETROLEUM (LP) PROPANE**

Liquefied Petroleum (LP) propane gas is heavier than air; therefore, it is imperative that your boiler is not installed in a pit or similar location that will permit heavier than air gas to collect.

Local Codes may require appliances fueled with LP gas be provided with an alarm or an approved means of removing unburned gases from the room. Check your local codes for this requirement.

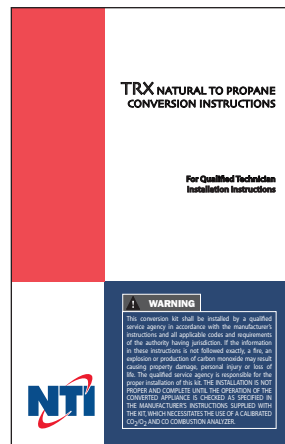



Figure 75 - Conversion Kit Instruction Cover

**! WARNING**

**Breathing Hazard - Carbon Monoxide Gas**



- Do not operate heater if flood damaged.
- Install vent system in accordance with local codes and manufacturers installation instructions.
- Do not obstruct heater air intake or exhaust. Support all vent piping per manufacturers installation instructions.
- Do not place chemical vapor emitting products near unit.
- According to NFPA 720, carbon monoxide detectors should be installed outside each sleeping area.
- Never operate the heater unless it is vented to the outdoors.
- Analyze the entire vent system to make sure that condensate will not become trapped in a section of vent pipe and therefore reduce the open cross sectional area of the vent.

**Breathing carbon monoxide can cause brain damage or death. Always read and understand instruction manual.**

LP-304

Before Installing	Yes	Note
Is there enough space to ensure proper installation?		
Does installation location allow for proper service clearances?		
Are water and gas lines properly sized and set at proper pressures for the installation?		
Is boiler location as near the exhaust vent / intake pipe terminations as possible?		
Have combustible materials been cleared from the installation location?		
Is there a drain close to the boiler?		
Water Piping	Yes	Note
Does boiler loop piping meet the minimum sizing requirements listed? <b>NOTE:</b> Smaller piping will cause performance problems.		
Does the system have an adequate air removal / CH Air separator?		
Has water chemistry been checked?		
Does water chemistry meet requirements?		
If water chemistry does not meet requirements, have treatment measures been put in place?		
Has the system been cleaned and flushed?		
Install Exhaust Vent and Intake Piping	Yes	Note
Has the boiler been vented with the approved materials listed in this manual or to meet local codes?		
Is air supply sufficient for proper boiler operation?		
Is total vent piping length within the maximum vent length restriction listed in this manual?		
Have venting lengths been minimized?		
Are terminations properly spaced from windows, doors, and other intake vents?		
Have all vent terminations been installed at least one foot above exterior grade and one foot above maximum snow accumulation level?		
Is vent piping properly supported?		
Has vent piping been checked for leaks?		
Has the exhaust vent line been pitched back to the boiler at a rate of 1/4" per foot?		
Have the exhaust vent and intake pipes been properly installed to the boiler?		
Is the condensate drain supported so as to not place strain on the boiler's condensate outlet fitting?		
Install Condensate Piping / Tubing and Components	Yes	Note
Have all condensate components included with the boiler been installed?		
Is the condensate line piped with the approved materials listed in this manual?		
Has the condensate line been routed to a laundry tub or other drain?		
Install Gas Piping	Yes	Note
If operating on Propane, has the appropriate LP Conversion Kit been installed and the LP Conversion Instructions been followed?		
Is the gas supply line a minimum of 3/4" in diameter?		
Is the gas supply line length and diameter adequate to deliver the required BTUs?		
When operating at maximum and minimum gas input rates, does the gas line pressure remain between 3.5 and 14"WC for Natural Gas, or between 8 and 13"WC for Propane?		
Does the gas type match the type indicated on the boiler rating plate? If converted to Propane, has the LP Conversion Label been affixed adjacent to the boiler's rating plate label?		
Has a union and shut-off valve been installed?		
Relief Valve	Yes	Note
Is the CH Pressure Relief Valve rated to 30 psi properly installed and the at least 3/4" discharge line run to an open drain and protected from freezing?		
Is the DHW Pressure Relief Valve rated to 150 psi properly installed and the at least 3/4" discharge line run to an open drain and protected from freezing?		

## Part 12 - Installation Checklist

<b>Wiring</b>	<b>Yes</b>	<b>Note</b>
Has the power and control been wired per boiler wiring diagram, this manual?		
Is the main electrical connection polarity within boiler requirements?		
Does the power supply voltage agree with the boiler rating plate? 120V AC?		
<b>Start-Up, Adjust, and Test</b>	<b>Yes</b>	<b>Note</b>
Has the boiler been started?		
If necessary, has the boiler gas valve been adjusted?		
Has the installation been customized per installation location requirements?		
Have all customized system parameters been tested?		
Has proper boiler operation been confirmed?		
<b>Burner Flame</b>	<b>Yes</b>	<b>Note</b>
Has the burner flame been checked?		
Have combustion values been verified with a calibrated combustion analyzer?		
If the flame does not appear normal, it may need to be cleaned by a qualified service technician. See flame sight glass window location.		
<b>Final Installation Approvals</b>		
<b>Signed by Technician</b>		<b>Date</b>

Table 33 - Installation Checklist



## A. Boiler Protection Devices

The boiler is protected from malfunctioning by means of internal checks performed by the electronic microprocessor PCB, which stops the boiler from operating if necessary. In the event of the boiler being shut off in this manner, a code appears on the display which refers to the type of shut-off and the reason behind it.

There are two types of shut-off:

### 1. Blocking Error

A blocking error means the boiler will restart automatically as soon as the problem which caused the error clears or is removed; the error is indicated by the «ERROR» symbol which appears on the display followed by the error code.

For example, if the boiler indicates a 110 error code, the error will clear automatically when the CH temperature decreases. The boiler will restart and operate normally.

**NOTE:** Contact a qualified service technician if the error continues to occur.

In the event of **Error 108 - Shut-off due to insufficient water pressure inside the heating circuit** - Pressure can be increased by filling the heating circuit. See filling and purging procedures, this manual.



Figure 76 - Blocking Error Example



Figure 77 - Shut-Off Error for Low Water Pressure

If Error 108 occurs frequently and system needs repeated refilling, turn the boiler off. Turn the external electric power to the OFF position. Shut off the main gas valve. Contact a qualified service technician to check for any leaks of water.

### 2. Lockout Error

A lockout error means the boiler does not return to operation after the error condition goes away. The **RESET** button must be pressed on the control panel to restore boiler operation.

If the error condition occurs often contact a qualified service technician.

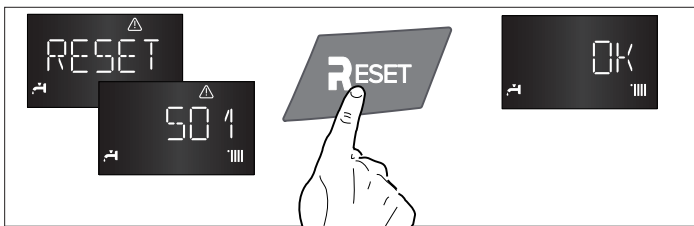

Figure 78 - Lockout Error Example

## ! WARNING

### Important

Contact a qualified service technician for assistance if a Lockout Error occurs frequently. For safety reasons, the boiler will permit a maximum of five (5) resets in 15 minutes (five [5] presses of the RESET button). A sixth (6th) attempt within this 15 minute period will lock out the boiler. The boiler will only operate again after the electrical supply has been disconnected and reconnected.

Repeated Lockout Error conditions could indicate a serious error with the boiler or installation. Failure to contact a qualified service technician to troubleshoot the error could result in substantial property damage, serious personal injury, or death.

## 3. Malfunction Warning

This warning is shown by the display in the following format:

5 P1 = FIRST IGNITION ATTEMPT UNSUCCESSFUL

The first part of the error code (e.g. 1 01) indicates the affected operational assembly.

- 1 - Primary Circuit
- 2 - Domestic Hot Water Circuit
- 3 - Internal Electronic Part
- 4 - External Electronic Part
- 5 - Ignition and Detection
- 6 - Air inlet - flue gas outlet
- 7 - Multi-zone Heating

## Part 13 - Troubleshooting

### B. Boiler Error Codes

Display	Description	Possible Remedies	Error Type	
<b>CH Circuit</b>				
<b>1 01*</b>	Overheat	Press the Reset button to clear the Error Code. If Error happens again: 1. Check for the correct functioning and positioning of the supply and return temperature probes. 2. Check for the correct functioning and positioning of the circulation pump. 3. Check the water pressure on the pressure gauge.	Blocking (Manual Reset)	
<b>1 03*</b>	Insufficient circulation or low water pressure: Gradient T supply > 12.6 °F / sec, three times	Press Reset to clear the Error Code. If Error happens again: 1. Check the water pressure on the pressure gauge. 2. Purge the air from the central heating circuit. 3. Check for the correct functioning and positioning of the supply and return temperature probes. 4. Check for the correct functioning and positioning of the circulation pump.	Blocking (Manual Reset)	
<b>1 04*</b>	Insufficient circulation or low water pressure: Gradient T supply > 27 °F / sec. or gradient T return > 27 °F / sec.	Press Reset to clear the Error Code. If Error happens again: 1. Check the water pressure on the pressure gauge. 2. Purge the air from the central heating circuit. 3. Check for the correct functioning and positioning of the supply and return temperature probes. 4. Check for the correct functioning and positioning of the circulation pump.		
<b>1 05*</b>	Insufficient circulation or low water pressure: T supply - T Return > 99 °F, three times	Press Reset to clear the Error Code. If Error happens again: 1. Check the water pressure on the pressure gauge. 2. Purge the air from the central heating circuit. 3. Check for the correct functioning and positioning of the supply and return temperature probes. 4. Check for the correct functioning and positioning of the circulation pump.		
<b>1 06*</b>	Insufficient circulation or low water pressure: T Return - T supply > 18 °F, three times	Press Reset to clear the Error Code. If Error happens again: 1. Check the water pressure on the pressure gauge. 2. Purge the air from the central heating circuit. 3. Check for the correct functioning and positioning of the supply and return temperature probes. 4. Check for the correct functioning and positioning of the circulation pump.		
<b>1 07*</b>	Insufficient circulation or water: T Return - T supply > 63 °F	Press Reset to clear the Error Code. If Error happens again: 1. Check the water pressure on the pressure gauge. 2. Purge the air from the central heating circuit. 3. Check for the correct functioning and positioning of the supply and return temperature probes. 4. Check for the correct functioning and positioning of the circulation pump.		
<b>1 08</b>	Fill system: No water in the primary circuit (P < Pmin).	This Error Code will go away when the condition is remedied. If Error happens again: 1. Ensure the system is filled with water. Ensure all valves are open to the appliance and there are no leaks. 2. Check wiring connections to low water pressure switch. Ensure all are secure. 3. Check low water pressure switch resistance. If resistance is not zero, replace the sensor. 4. If the problem persists, replace the main control.		Blocking (Auto Reset)
<b>1 10</b>	CH Flow temp. probe circuit open / short circuit	This Error Code will go away when the CH temperature decreases. If Error happens again: 1. Check CH temperature sensor. Ensure connections are secure. 2. Check sensor resistance. If resistance is zero, replace the sensor. 3. If the problem persists, replace the main control.		
<b>1 12</b>	CH Return temp. probe circuit open / short circuit	This Error Code will go away when operating temperature decreases. If Error happens again: 1. Check return temperature sensor. Ensure connections are secure. 2. Check return sensor resistance. If resistance does not match Table 36 – Sensor Temperature Resistance - replace the sensor. 3. If the problem persists, replace the main control.		
<b>1 14</b>	External sensor circuit open / short circuit	The Error Code will go away when the condition is remedied. If Error happens again: 1. Check outdoor sensor. Ensure all wiring connections are intact and secure. If the sensor wires were secured to the wall with staples, the wires may have been damaged. 2. Check outdoor sensor resistance. If resistance does not match Table 36 – Sensor Temperature Resistance - replace the sensor. 3. If the problem persists, replace the outdoor sensor. <b>NOTE:</b> When this error occurs, the appliance will operate at a fixed temperature for CH demands, equal to setting 4.0.2 (or 5.0.2/6.0.2 for Zones 2/3).	Warning	
<b>1 16</b>	Floor Thermostat contact open	1. If parameter 223 is set to 1 and a floor safety thermostat is not present, set the parameter 223 to 0 or connect a floor safety thermostat. 2. If parameter 223 is set to 1 and a floor safety thermostat is present reduce the CH set-point.	Blocking (Auto Reset)	

Display	Description	Possible Remedies	Error Type
<b>1 P1</b>	Insufficient circulation or missing water: Gradient T supply > 12.6 °F / sec		Warning
<b>1 P2</b>	Insufficient circulation or missing water: T supply - T return > 99 °F		Warning
<b>1 P3</b>	Inadequate circulation or missing water: T return - T supply > 18 °F		Warning
<b>DHW Circuit</b>			<b>Reset?</b>
<b>2 01</b>	Damaged or shorted DHW temperature probe	Applicable to Combi models only. 1. Check DHW outlet temperature probe and wiring. Ensure connections are secure. 2. Check sensor resistance. If resistance does not match Table 36 - Sensor Temperature Resistance - replace the sensor. 3. If problem persists, replace the main control. <b>NOTE:</b> When this error occurs, the controller references the boiler return temperature sensor instead of the DHW outlet sensor and continues to function for both CH and DHW demands.	Warning
<b>2 03</b>	Storage temp. probe circuit open / short circuit	Only applicable to Non-Combi boilers with DHW tank sensor. Check tank sensor wiring. If not using a tank sensor, set parameter 2.2.8 = 2. <b>NOTE:</b> When this error occurs the appliance continues to meet CH demands.	Blocking (Auto Reset)
<b>2 05</b>	DHW In Probe Open Circuit		
<b>2 09</b>	Storage overheating (> 176 °F = on; <175 °F; off)	Check tank sensor and wiring. Replace if damaged. <b>NOTE:</b> When this error occurs the appliance will continue to operate for CH demands.	
<b>2 P2</b>	Anti - Legionella function not completely finished		Warning
<b>Internal PCB's</b>			<b>Reset?</b>
<b>3 01</b>	Display error Eeprom	Switch the boiler OFF and ON at the main electrical power supply. If the problem happens again replace the main PCB.	Blocking (Auto Reset)
<b>3 02</b>	Communication error GP - GIU	Switch the boiler OFF and ON at the main electrical power supply. If the problem happens again: 1. Check the connection between the main PCB and the HMI 2. Replace the main PCB.	
<b>3 03</b>	PCB internal error	Switch the boiler OFF and ON at the main electrical power supply. If the problem happens again replace the main PCB.	
<b>3 04</b>	Too many (> 5) resets in 15 minutes (1) Turn Off the Power to the Boiler	Switch the boiler OFF and ON at the main electrical power supply.	
<b>3 05</b>	PCB internal error	Switch the boiler OFF and ON at the main electrical power supply. If the problem happens again replace the main PCB.	Blocking (Manual Reset)
<b>3 06</b>	PCB internal error	Switch the boiler OFF and ON at the main electrical power supply. If the problem happens again replace the main PCB.	
<b>3 07</b>	PCB internal error	Switch the boiler OFF and ON at the main electrical power supply. If the problem happens again replace the main PCB.	
<b>3 09</b>	Gas relay check failed	Switch the boiler OFF and ON at the main electrical power supply. If the problem happens again replace the main PCB.	
<b>3 P9</b>	Sched. Maintenance-Call for Service	Reset the error with the parameter 852	Warning
<b>External P.C.B.'s</b>			
<b>4 11</b>	Room sensor circuit open or short circuit Zone 1		Blocking (Auto Reset)
<b>4 12</b>	Room sensor circuit open or short circuit Zone 2		
<b>4 13</b>	Room sensor circuit open or short circuit Zone 3		
<b>4 30</b>	Detected accessory wired to BUS connection	If connecting an NTI zone controller to the BUS connection, ensure parameter 11.0.0 = 1.	Warning
<b>4 31</b>			
<b>Ignition and Detection</b>			
<b>5 01</b>	No flame detected (3 times)	Press the Reset button to clear the error code. If Error happens again: 1. Monitor the gas pressure to the appliance while in operation. Ensure pressure is between 3.5 and 10.5" WC (Natural Gas), or between 8 and 13" WC for boilers converted to Propane (LP) operation. 2. Check gas valve wire. Ensure connection is secure. 3. Check flame detection sensor. Ensure connections are secure. Normal operating settings are more than 2.5DC before ignition; less than 2.5DC after ignition. 4. Check igniter transformer for proper connection. 5. Clean the spark igniter with steel wool to remove oxides. Ensure proper separation (3-4 mm). 6. Replace the spark igniter if damaged. 7. Ensure that the flame is stable when lit. 8. If the problem persists, replace the main control.	Blocking (Manual Reset)

## Part 13 - Troubleshooting

Display	Description	Possible Remedies	Error Type
<b>5 02</b>	Flame detected with gas valve closed	This Error Code will go away when the condition is remedied. <ol style="list-style-type: none"> <li>1. If Error happens again disconnect the flame detection electrode. Then press Reset.</li> <li>2. If the error does not happen again replace the flame detection electrode.</li> <li>3. If the error happens again replace the main PCB.</li> </ol>	Blocking (Auto Reset)
<b>5 04</b>	Detection of 10 flame lifts in one operating cycle	Press Reset to clear the error code. If Error happens again: <ol style="list-style-type: none"> <li>1. Monitor the gas pressure to the appliance while in operation. Ensure pressure is between 3.5 and 10.5"WC.</li> <li>2. Check gas valve wire. Ensure connection is secure.</li> <li>3. Check flame detection sensor. Ensure connections are secure. Normal operating settings are more than 2.5DC before ignition, less than 2.5DC after ignition.</li> <li>4. Check vent terminations. Ensure there are no blockages.</li> <li>5. Ensure that the flame is stable when lit.</li> <li>6. If the problem persists, replace the main control.</li> </ol>	Blocking (Manual Reset)
<b>5 P1</b>	1st Ignition Failed	<ol style="list-style-type: none"> <li>1. Monitor the gas pressure to the appliance while in operation. Ensure pressure is between 3.5 and 10.5"WC (Natural Gas), or between 8 and 13"WC for boilers converted to Propane (LP) operation.</li> <li>2. Check gas valve wire. Ensure connection is secure.</li> <li>3. Check flame detection sensor. Ensure connections are secure. Normal operating settings are more than 2.5DC before ignition; less than 2.5DC after ignition.</li> <li>4. Check igniter transformer for proper connection.</li> <li>5. Clean the spark igniter with steel wool to remove oxides. Ensure proper separation (2/16"-3/16").</li> <li>6. Replace the spark igniter if damaged.</li> <li>7. Ensure that the flame is stable when lit.</li> <li>8. If the problem persists, replace the main control.</li> </ol>	Warning
<b>5 P2</b>	2nd Ignition Failed	<ol style="list-style-type: none"> <li>1. Monitor the gas pressure to the appliance while in operation. Ensure pressure is between 3.5 and 10.5"WC (Natural Gas), or between 8 and 13"WC for boilers converted to Propane (LP) operation.</li> <li>2. Check gas valve wire. Ensure connection is secure.</li> <li>3. Check flame detection sensor. Ensure connections are secure. Normal operating settings are more than 2.5DC before ignition; less than 2.5DC after ignition.</li> <li>4. Check igniter transformer for proper connection.</li> <li>5. Clean the spark igniter with steel wool to remove oxides. Ensure proper separation (2/16"-3/16").</li> <li>6. Replace the spark igniter if damaged.</li> <li>7. Ensure that the flame is stable when lit.</li> <li>8. If the problem persists, replace the main control.</li> </ol>	Warning
<b>5 P3</b>	Detection of Flame loss during run	<ol style="list-style-type: none"> <li>1. Monitor the gas pressure to the appliance while in operation. Ensure pressure is between 3.5 and 10.5"WC (Natural Gas), or between 8 and 13"WC for boilers converted to Propane (LP) operation.</li> <li>2. Check gas valve wire. Ensure connection is secure.</li> <li>3. Check flame detection sensor. Ensure connections are secure. Normal operating settings are more than 2.5DC before ignition, less than 2.5DC after ignition.</li> <li>4. Check vent terminations. Ensure there are no blockages.</li> <li>5. Ensure that the flame is stable when lit.</li> <li>6. If the problem persists, replace the main control.</li> </ol>	Warning
<b>5 P6</b>	3rd and 4th Ignition Failed	<ol style="list-style-type: none"> <li>1. Monitor the gas pressure to the appliance while in operation. Ensure pressure is between 3.5 and 10.5"WC (Natural Gas), or between 8 and 13"WC for boilers converted to Propane (LP) operation.</li> <li>2. Check gas valve wire. Ensure connection is secure.</li> <li>3. Check flame detection sensor. Ensure connections are secure. Normal operating settings are more than 2.5DC before ignition; less than 2.5DC after ignition.</li> <li>4. Check igniter transformer for proper connection.</li> <li>5. Clean the spark igniter with steel wool to remove oxides. Ensure proper separation (2/16"-3/16").</li> <li>6. Replace the spark igniter if damaged.</li> <li>7. Ensure that the flame is stable when lit.</li> <li>8. If the problem persists, replace the main control.</li> </ol>	Warning

Display	Description	Possible Remedies	Error Type
<b>Air Intake / Exhaust Gas Outlet</b>			
<b>6 02</b>	Exhaust NTC detects Vent Temperature is greater than 204°F (96°C)	<p>Press the Reset button to clear the error code.</p> <p>If Error happens again:</p> <ol style="list-style-type: none"> <li>1. Check exhaust temperature sensor. Ensure connections are secure.</li> <li>2. Check sensor resistance. If resistance is zero, replace the sensor.</li> <li>3. Check flue gas temperature. Compare it to the reading on parameter 834. If the parameter 834 reading is significantly higher, replace the flue sensor.</li> <li>4. Check exhaust vent for blockage.</li> <li>5. If the problem persists, check the combustion chamber and clean, if necessary. Also, descale the heat exchanger.</li> <li>6. If the problem persists, replace the control.</li> <li>7. If the problem persists, replace the heat exchanger.</li> </ol>	Blocking (Manual Reset)
<b>6 03</b>	APS Open	<p>Press the Reset button to clear the error code.</p> <ol style="list-style-type: none"> <li>1. Check APS and main controller connections. Ensure all are secure.</li> <li>2. Check APS resistance. If resistance is not zero, replace the switch.</li> <li>3. Check APS hose. Ensure it is connected and in good condition.</li> <li>4. Check condensate line and termination for blockages.</li> <li>5. Check exhaust vent for blockages.</li> <li>6. If the problem persists, replace the main control.</li> </ol>	
<b>6 05</b>	Exhaust NTC circuit open or short circuit	<p>This Error Code will go away when the condition is remedied.</p> <ol style="list-style-type: none"> <li>1. Check exhaust temperature sensor. Ensure connections are dry and secure.</li> <li>2. If flue is very cold, &lt; 14°F (-10°C), remove sensor and warm it, then reinstall.</li> <li>3. If flue is very hot – see error 6 02.</li> <li>4. Check exhaust vent for blockages.</li> </ol>	Blocking (Auto Reset)
<b>6 12*</b>	Insufficient fan speed (<500 for 3 seconds or RPM min -300 for 3 minutes)	<p>Press the Reset button to clear the error code.</p> <p>If Error happens again:</p> <ol style="list-style-type: none"> <li>1. Check the connections to the fan. Ensure all are secure.</li> <li>2. If the fan does not rotate during the ignition sequence, check for 8Vac 26.5VDC power at the fan connection. If 8Vac 26.5VDC power is present at the control, replace the fan. If the blower does not have 8Vac 26.5VDC power, check power at the control. If 8Vac 26.5VDC power is not present at the control, replace the control.</li> <li>3. If the problem persists, replace the main control.</li> </ol>	Blocking (Manual Reset)
<b>NOAVL</b>	PCB Error	<ol style="list-style-type: none"> <li>1. Check parameter 046. If it is set to UNDEF, it must be changed according to the boiler's application. For example: <ul style="list-style-type: none"> <li>• <b>b--SIN</b> - Sets the boiler as a single boiler (default setting).</li> <li>• <b>b--MAS</b> - Sets the master boiler of a cascade system.</li> <li>• <b>b--FL1</b> - Sets follower #1 of a cascade system.</li> <li>• <b>b--FL2</b> - Sets follower #2 of a cascade system.</li> <li>• <b>b--FL3</b> - Sets follower #3 of a cascade system.</li> <li>• <b>b--FL4</b> - Sets follower #4 of a cascade system.</li> <li>• <b>b--FL5</b> - Sets follower #5 of a cascade system.</li> <li>• <b>b--FL6</b> - Sets follower #6 of a cascade system.</li> <li>• <b>b--FL7</b> - Sets follower #7 of a cascade system.</li> </ul> </li> <li>2. If the problem persists, check the eBus2 wires. Ensure they are not shorted together.</li> <li>3. If the problem persists, replace the main control.</li> </ol>	After the issue is corrected the error will clear.
<b>EMERG</b>	Incorrect wiring to BUS connection (When in Emergency mode, the boiler operates in CH mode with a target boiler temperature of 113°F)	<ol style="list-style-type: none"> <li>1. The control has sensed a short circuit on the BUS connection – disconnect field wiring from BUS connection.</li> <li>2. If connecting an NTI room sensor or zone controller to the BUS connection, check for correct polarity and short circuits of the wiring.</li> <li>3. If boiler is part of a cascade, check for proper daisy-chain wiring between the BUS connection of each boiler.</li> </ol> <p><b>NOTE:</b> It is possible to adjust the Emergency Setpoint via parameter 2.10.3.</p>	

Table 34 - Boiler Error Codes

**Important**

Contact a qualified service technician for assistance if a Lockout Error occurs frequently. For safety reasons, the boiler will permit a maximum of five (5) resets in 15 minutes (five [5] presses of the RESET button). A sixth (6th) attempt within this 15 minute period will lock out the boiler permanently. The boiler will only operate again after the electrical supply has been disconnected and reconnected. Repeated Lockout Error conditions could indicate a serious error with the boiler or installation. Failure to contact a qualified service technician to troubleshoot the error could result in substantial property damage, serious personal injury, or death.

\*Error is resettable remotely via NTI Tele-Diagnostic Service, NTI Remote Contractor.

### DANGER

The boiler must be inspected and serviced annually, preferably at the start of the heating season, by a qualified service technician. In addition, the maintenance and care of the boiler as outlined in this manual must be performed by the user/owner to assure maximum efficiency and reliability. Follow the maintenance procedures given throughout this manual. Failure to perform the service and maintenance or follow the directions in this manual could damage the boiler or system components, resulting in substantial property damage, severe personal injury, or death.

#### A. Procedures

Periodic maintenance should be performed once a year by a qualified service technician to ensure that all the equipment is operating safely and efficiently. The owner should make necessary arrangements with a qualified heating contractor for periodic maintenance of the boiler. The installer must also inform the owner that a lack of proper care and maintenance of the boiler may result in a hazardous condition.

#### B. Maintenance That May be Performed by the User

##### Check the Surrounding Area

### DANGER

To prevent the potential of substantial property damage, severe personal injury, or death, eliminate all the materials listed in Table 6 from the area surrounding the boiler and the vicinity of the combustion air intake. If contaminants are found:

- Remove products immediately from area.
- If contaminants have been there for an extended period, call a qualified service technician to inspect the boiler for possible damage from acid corrosion.

If products cannot be removed, immediately call a qualified service technician to re-pipe the combustion air intake piping away from the contaminated areas.

##### Ensure the Cabinet is Closed When the Boiler is Operating

The boiler cabinet must be closed when the boiler is operating.

##### Combustible/Flammable Materials

Do not store combustible materials, gasoline, or other flammable vapors or liquids near the boiler. If found, remove these materials immediately.

##### Air Contaminants

If allowed to contaminate combustion air, products containing chlorine or fluorine will produce acidic condensate that will cause significant damage to the boiler. Read the list of potential contaminants and areas likely to have these contaminants in Table 6. If any of these contaminants are in the room where the boiler is located, or combustion air is taken from one of the areas listed, the contaminants must be removed immediately or the intake pipe must be relocated to another area.

##### Check the Power Source

Make sure the power cord and the main power line are properly connected to the manual switch box inside the boiler.

##### Check the Status of the Control Panel

Observe the Control Panel to ensure the boiler is powered on and to check for any error codes. Clear any debris from the panel.

##### Check CH Pressure Gauge

Ensure the pressure reading on the CH gauge does not exceed 30 psig. Higher pressure readings may indicate a problem with the expansion tank. Immediately contact a qualified service technician to inspect the boiler and system.

##### Check Exhaust Vent and Intake Pipe Terminations

Verify that the boiler exhaust vent and intake pipe terminations are clean and free of obstructions. Remove any debris from the exhaust vent or intake pipe openings. If removing the debris does not allow the boiler to operate correctly, contact your qualified service technician to inspect the boiler and the vent system.

##### Check Exhaust Vent and Intake Piping

Visually inspect the exhaust vent for any signs of blockage, leakage, or deterioration of the piping. Inspect the exhaust vent bracing. Ensure bracing is undamaged and in good condition. Notify a qualified service technician immediately if any problems are found.

### WARNING

Failure to inspect the venting system and have it repaired by a qualified service technician can result in vent system failure, causing severe personal injury or death.

##### Check Pressure Relief Valve

1. Visually inspect the primary pressure relief valve and discharge pipe for signs of weeping or leakage.
2. If the pressure relief valve often weeps, the expansion tank may not be operating properly. Immediately contact a qualified service technician to inspect the boiler and system.

##### Operate Pressure Relief Valve

1. Before proceeding, verify that the relief valve outlet has been piped to a safe place of discharge, avoiding any possibility of scalding from hot water.
2. Shut power off to the boiler. To avoid scalding, wait for boiler to cool before operating the relief valve.

### WARNING

To avoid water damage or scalding due to relief valve operation, a discharge line must be connected to the valve outlet and directed to a safe place of disposal. This discharge line must be installed by a qualified service technician in accordance with the boiler installation manual. The discharge line must be terminated so as to eliminate possibility of severe burns or property damage should the valve discharge.

3. Lift the relief valve lever. If water flows freely, release the lever and allow the valve to seat. Watch the end of the relief valve discharge pipe to ensure that the valve does not weep after the line has had time to drain. If the valve weeps, lift the lever again to attempt to clean the valve seat. If the valve does not properly seat and continues to weep, contact a qualified service technician to inspect the valve and system.
4. If water does not flow from the valve when you completely lift the lever, the valve or discharge line may be blocked. Immediately shut the boiler down per instructions on page 2 and call a qualified service technician to inspect the valve and system.
5. If relief valve seats properly, restore power to the boiler. Observe operation for five minutes and ensure it operates properly.

##### Check the Condensate Drain System

1. While the boiler is running, check the discharge end of the condensate drain tubing. Ensure no flue gas is leaking from the condensate drain tubing by holding your fingers near the opening.
2. If you notice flue gas leaking from the opening, this indicates a dry condensate drain trap. If problem persists, contact a qualified service technician to inspect the boiler, condensate line and condensate trap.



- If applicable, check the condensate neutralizer and ensure it is full of condensate neutralizing marble chips.

### C. Maintenance Only to be Performed by a Qualified Service Technician

#### Removing the Cabinet Cover and Inspecting the Boiler

Before carrying out any work on the boiler, switch off the power supply at the external power switch and circuit breaker. Close the external gas shutoff.

## ! DANGER

Ensure power and gas to the appliance are shut off before performing the following operations. Failure to do so will result in substantial property damage, severe personal injury, or death.

See Figure 79 to access the interior of the boiler:

- Release the four (4) latches from the front cover (two [2] each side). Lift and remove the front cover from the cabinet (a).
- Remove the screw securing the control panel to the cross-member (b).
- Push in the tabs and pull the control panel housing forward (c).

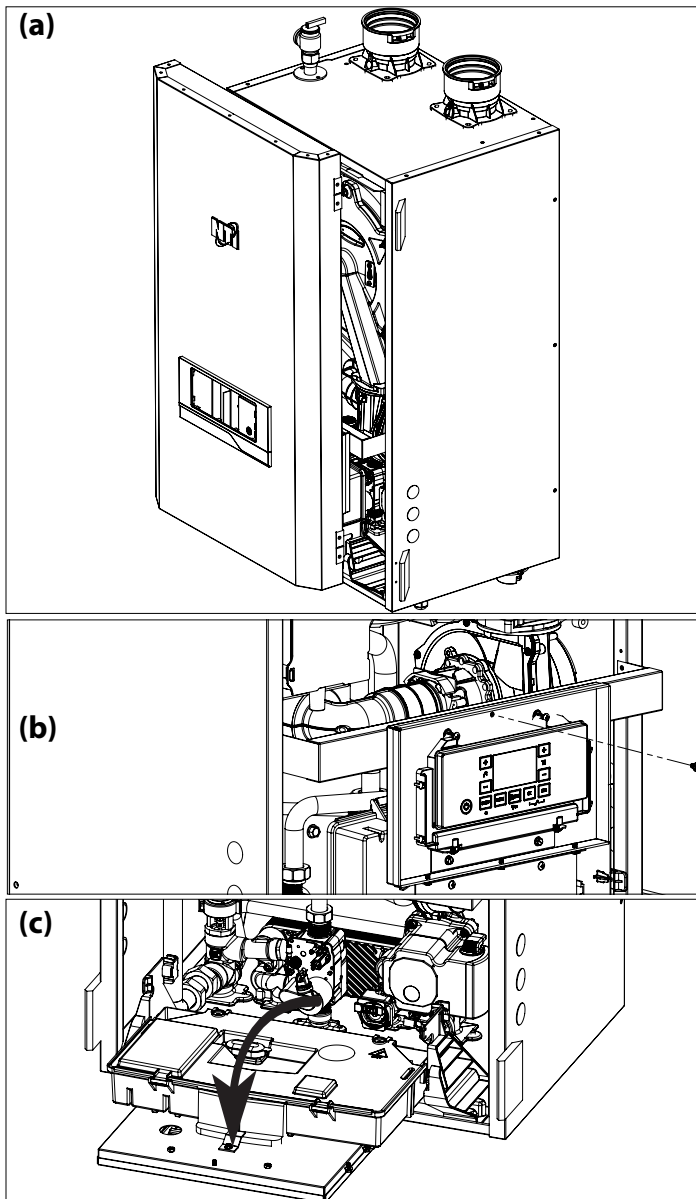

Figure 79 - Removing the Cover and Control Panel Housing

#### Check Water and Gas Piping

- Remove the boiler cover and perform a gas leak inspection following Operating Instructions on page 2 of this manual. If gas odor or leak is detected, follow procedures on page 2. Call a qualified service technician.
- Visually inspect for leaks around the boiler water connections and around the heat exchanger. Visually inspect the external system piping, circulators, and system components and fittings. Immediately call a qualified service technician to repair any leaks.

## ! WARNING

Have leaks fixed at once by a qualified service technician. Failure to comply could result in substantial property damage, severe personal injury, or death.

#### Before Starting Maintenance:

- Ensure the power and gas remain off.
- Close the valves of heating and hot water circuit.
- Remove the front panel as shown in Figure 79.
- If necessary, empty the appliance on the water side.

#### Draining Procedure

To drain the heating system:

- Ensure the boiler power and gas remain off.
- Open the system drain valve and collect the escaping water in a container.
- Drain the water from the lowest points of the system (where applicable).

If the system is to be inactive in areas where the room temperature may fall below 0°C during winter, it is recommended that anti-freeze liquid be added to the heating system in order to avoid the need for repeated draining. Ensure the antifreeze used is compatible with the stainless steel boiler heat exchanger.

It is recommended to use antifreeze which contains PROPYLENE GLYCOLS as these inhibit corrosion. Use the quantities and formulation suggested by the antifreeze manufacturer to protect against freezing in your region and prevent scaling and corrosion.

## ! WARNING

NEVER use any toxic chemical, including automotive, standard glycol antifreeze, or ethylene glycol made for hydronic (non-potable) systems. These chemicals can attack gaskets and seals in water systems, are poisonous if consumed, and can cause personal injury or death.

Regularly check the pH level of the water/anti-freeze mix in the boiler circuit and replace it when the value measured is lower than the limit prescribed by the manufacturer.

#### DO NOT MIX DIFFERENT TYPES OF ANTI-FREEZE.

The manufacturer will not be held liable for any damage caused by the appliance or the system due to the use of inappropriate antifreeze substances or additives.

#### Draining the DHW System and Indirect Water Heater

Every time there is a danger of freezing, the domestic hot water system must be drained as follows:

- Shut off the main water inlet valve.
- Open all the hot and cold water taps.
- Drain the water from the lowest points of the system.

## Part 14 - Maintenance

### ! WARNING

Water drained from the boiler could be scalding hot. Wait for the boiler to cool before draining water, and take precautions when draining water. Failure to do so could result in property damage, personal injury, or death.

### ! WARNING

Allowing the boiler to operate with a dirty combustion chamber will hurt operation. Failure to clean the heat exchanger as needed by the installation location could result in boiler failure, property damage, personal injury, or death. Such product failures ARE NOT covered under warranty.

The combustion chamber insulation in this product contains ceramic fiber material. Ceramic fibers can be converted to cristobalite in very high temperature applications. The International Agency for Research on Cancer (IARC) has concluded, "Crystalline silica inhaled in the form of quartz or cristobalite from occupational sources is carcinogenic to humans (Group 1)."

- Avoid breathing dust and contact with skin and eyes.
- Use a NIOSH certified dust respirator (N95). This type of respirator is based on the OSHA requirements for cristobalite at the time this document was written. Other types of respirators may be needed depending on job site conditions. Current NIOSH recommendations can be found on the NIOSH website: <http://www.cdc.gov/niosh/homepage.html>. NIOSH approved respirators, manufacturers, and phone numbers are also listed on this website.
- Wear long-sleeved, loose fitting clothing, gloves, and eye protection.
- Apply enough water to the combustion chamber lining to prevent dust.
- Wash potentially contaminated clothes separately from other clothing. Rinse clothes washer thoroughly.

NIOSH stated First Aid.

- Eye: Irrigate immediately.
- Breathing: Fresh air.

### Cleaning the Heat Exchanger Combustion Chamber

\*Before beginning this procedure, have on hand the following items:

- a nylon or other non-metallic brush
- an FDA approved liquid lime scale remover in a spray bottle
- gloves and eye protection

1. Remove the silencer.

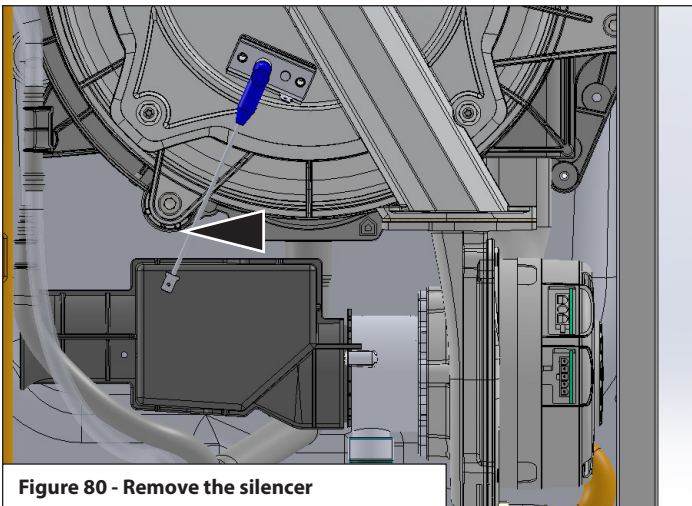

Figure 80 - Remove the silencer

2. Unscrew the two nuts and remove the gas pipe.

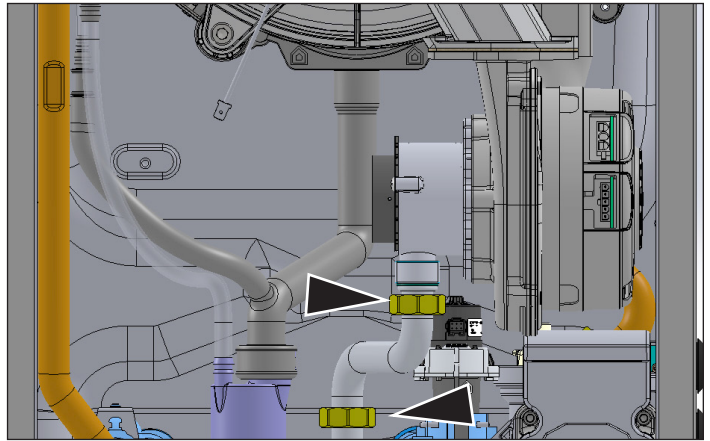

Figure 81 - Remove the gas pipe

3. Remove the gas diaphragm (if present).

4. Disconnect the electrical connections from the electrodes, igniter, and blower.

5. Unscrew the four (4) nuts on the burner door and remove it.

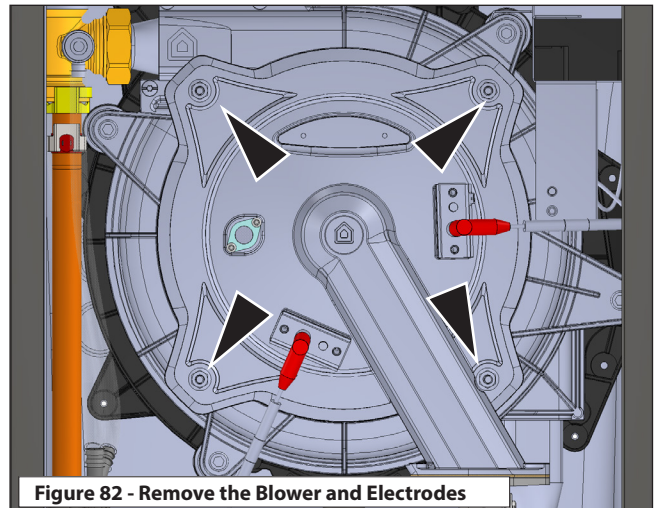

Figure 82 - Remove the Blower and Electrodes

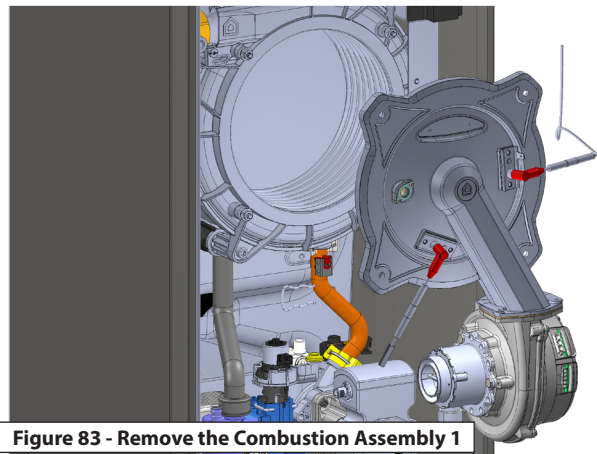

Figure 83 - Remove the Combustion Assembly 1

6. Check the back wall insulation and replace if necessary.

7. Disconnect the condensate hose and siphon cap from the boiler.

- Clean the combustion chamber by spraying water or solution into the combustion assembly and monitor the flow through the combustion system. Liquid should flow freely through each tube. If there is an obstruction, increase the flow on the tube to force the blockage out.

**! WARNING**

Protect the back wall insulation from water before performing any cleaning. Failure to do so could result in damage to the insulation, improper boiler operation, personal injury, or death.

Do not use solvents to clean any of the boiler components. The components could be damaged, resulting in unreliable or unsafe boiler operation, substantial property damage, severe personal injury, or death.

- After all maintenance is complete, reinstall the combustion assembly. Ensure all gaskets are installed and all components are tightened properly.
- Restore power and gas to the boiler. Restart the boiler. Check for leaks in the combustion system. Observe operation for 5 to 10 minutes.

If boiler is operating properly, condensate is flowing normally, and no gas leaks are detected, combustion coil cleaning is complete.

**Checking the Burner**

While the combustion assembly is removed from the heat exchanger, inspect the burner. Proceed as follows:

- Unscrew the four screws securing the two electrodes to the burner plate.

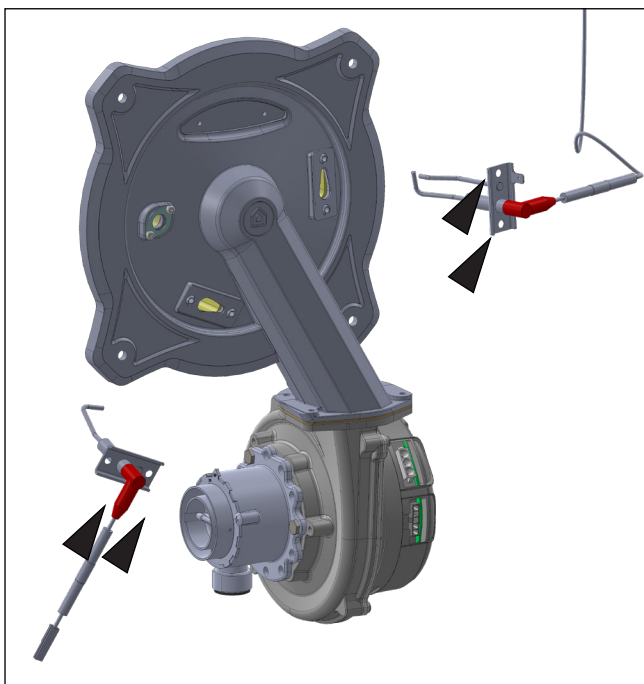

**Figure 84 - Remove the Electrodes**

- Remove the ceramic fiber.
- Remove the four screws and pull the burner toward you.

**NOTE:** Whenever replacing the burner, ALWAYS replace the burner gasket.

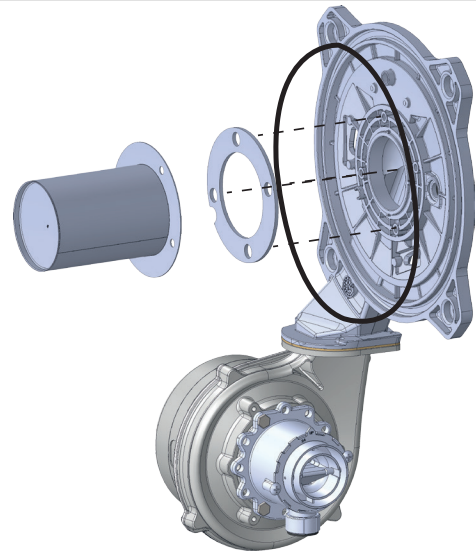

**Figure 85 - Disassembled Burner Assembly**

- Verify and replace the other gaskets if they are damaged or showing signs of deterioration.
- Make sure that the burner is not damaged. Replace if necessary.
- Reassemble the burner assembly.
- Ensure the combustion assembly sealing ring is not damaged. Replace if necessary.

**! DANGER**

Failure to replace a damaged sealing ring will result in exhaust gas leaks, substantial property damage, severe personal injury, or death.

- Reinstall the two removed electrodes with the four removed screws.
- Reassemble the combustion assembly and tighten the four screws.
- Reconnect the gas line. Replace the sealing ring.
- Reconnect the electrode electrical connections.
- Reinstall the silencer.

**Clean the Condensate Trap**

- Remove the condensate drain hose from the bottom of the boiler.

**! WARNING**

Take care when removing the condensate hose, as condensate may escape. Failure to do so could result in property damage due to leaks, personal injury, or death.

- Working from below the boiler, remove the siphon cap retaining clip. Then remove the siphon cap by depressing the two (2) lateral hinges (use a tool if necessary).
- Remove the cone and the ball.
- Clean each part.
- When the condensate trap is sufficiently clean, reassemble in the reverse order.

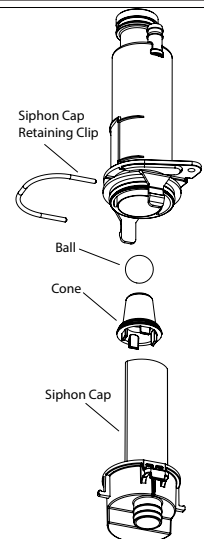

**Figure 86 - Clean the Condensate Trap**

**NOTE:** Ensure all parts shown in Figure 86 are installed with the boiler. If any parts are missing DO NOT operate the boiler. Replace the entire condensate trap assembly.



## Part 14 - Maintenance

### **! WARNING**

Do not install the condensate assembly if a component is lost or missing. Replace the entire assembly. Failure to follow this warning could result in property damage, serious personal injury, or death.

6. If a condensate neutralizer kit is installed, check the assembly when cleaning the condensate trap, and replenish the limestone chips if necessary. When replacing the limestone chips, take care to ensure chips are no smaller than ½" to avoid blockage in condensate piping. See Figure 44 for piping details.
7. Check condensate piping for sagging and/or leakage. Repair any sags or leaks before restoring power to the boiler.
8. If the boiler has a condensate pump, ensure the pump operates properly before considering maintenance complete.

#### **Cleaning the DHW Filter (Combi Models ONLY)**

1. Remove the clip on the flow meter (1).

### **! DANGER**

When servicing is complete, make sure the siphon cap and retaining clip are replaced securely. The condensate trap assembly **MUST BE PROPERLY INSTALLED** according to these instructions when operating the boiler. Operating the boiler without the condensate trap assembly will cause flue gases to leak and result in serious personal injury or death.

### **CAUTION**

It is very important that the condensate piping be no smaller than ¾". To prevent sagging and maintain pitch, condensate piping should be supported with pipe supports, and pitched ¼" per foot to allow for proper drainage.

The condensate line must remain unobstructed, allowing free flow of condensate. If condensate freezes in the line, or if line is obstructed in any other manner, condensate can exit from the tee, resulting in potential water damage to property.

2. Remove the flow meter cap (2).

### **! WARNING**

Ensure the combi boiler DHW heating system has been valved off from the system and drained **BEFORE** attempting to remove the DHW filter. Failure to do so could result in property damage, serious personal injury, or death.

Water drained from the boiler could be scalding hot. Wait for the boiler to cool before draining water, and take precautions when draining water. Failure to do so could result in property damage, personal injury, or death.

3. Remove the flow meter turbine (3).
4. Remove and clean the filter (4).

5. Clean the filter with a toothbrush and clean running water.
6. Reinstall the DHW inlet filter.
7. Refill the DHW circuit following the filling and purging instructions in this manual.
8. Restore gas and power to the boiler.

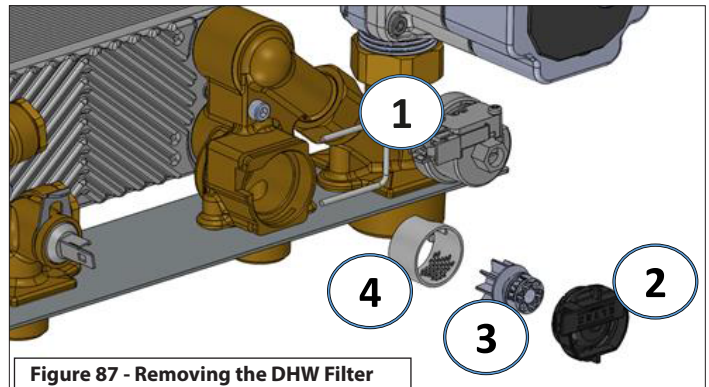

Figure 87 - Removing the DHW Filter

#### **D. Replacing Components**

At any point in time over the boiler's service life it may be necessary to replace boiler components. If the boiler displays an error message, determine its cause and possible remedies.

If the remedy is replacement of a component, ensure:

1. That the boiler is powered OFF. Press the ON/OFF button to turn the boiler off. Then turn the main electrical power to the boiler off at the circuit breaker.
2. The boiler electrical connection is connected properly. A loose electrical connection could be the root cause of problems.
3. The front cover has been removed.
4. The main shutoff gas valve is closed.
5. All water valves to and from the boiler (supply, return, inlet, outlet) are closed.
6. If necessary, the water has been drained from the boiler and/or appropriate circuit.
7. No water can get into the display / control panel.

#### **Replacing the Burner**

1. Remove the front cover and pivot the electronic housing following the instructions described in **Removing the Cabinet Cover and Inspecting the Boiler**.
2. Remove the combustion assembly as described in **Cleaning the Heat Exchanger Combustion Chamber**.
3. Remove, inspect, and replace the burner as described in **Checking the Burner**.
4. Replace all damaged seals that are damaged or showing signs of wear.

### **! DANGER**

Failure to replace a damaged sealing ring will result in exhaust gas leaks, substantial property damage, severe personal injury, or death.

5. Proceed in the reverse order to reinstall the components.

### Replacing the Fan

1. Remove the silencer and gas line as described in Cleaning the Heat Exchanger Combustion Chamber.
2. Loosen the three [3] screws to release the Mixer (1) from the fan (5). Ensure the O-Ring (4) is not damaged or deteriorating.
3. Loosen the three [3] screws to release the fan from the heat exchanger.

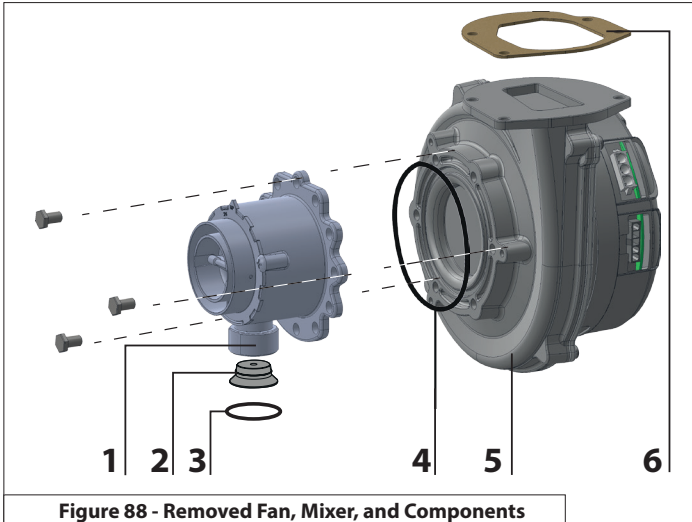

Figure 88 - Removed Fan, Mixer, and Components

**Legend:**

- |  |                                     |
|--|-------------------------------------|
| 1 - Mixer (when converting to Propane, install the Mixer included in the Natural Gas to Propane Conversion Kit)                            | 3 - Gas Seal                        |
| 2 - Gas Diaphragm if applicable (Models converted to Propane require a Gas Diaphragm - see Natural Gas to Propane Conversion Instructions) | 4 - O-Ring                          |
|  | 5 - Fan                             |
|  | 6 - Fan to Air Inlet Channel Gasket |

4. Reassemble the mixer and fan assembly in the reverse order. Ensure the O-Ring (4) is installed between the mixer and fan.

**! DANGER**

Ensure that the correct gas diaphragm and mixer are used for the correct fuel type for the boiler - Natural Gas or Propane. See Conversion Kit Instructions. Failure to do so will result in substantial property damage, severe personal injury, or death.

5. Reinstall the fan and combustion assembly components as described in Cleaning the Heat Exchanger Combustion Chamber. Ensure the gasket (6) is assembled between the fan and air inlet channel.

**! DANGER**

Failure to replace damaged or deteriorating gaskets or O-Rings will result in exhaust gas leaks, substantial property damage, severe personal injury, or death.

### Replacing the Main Heat Exchanger

1. Drain the boiler and remove the combustion assembly as described in **Cleaning the Heat Exchanger Combustion Chamber**.
2. Remove the exhaust vent adapter on the top of the boiler.
3. Remove the two (2) screws securing the CH relief valve pipe assembly to the top of the boiler.
4. Remove the three clips on the automatic air purging device (b), then remove the CH relief valve pipe (a) from the top of the boiler.
5. Disconnect the bottom of the heating supply pipe (c) from the hydraulic group, then from the automatic air purging device (b).

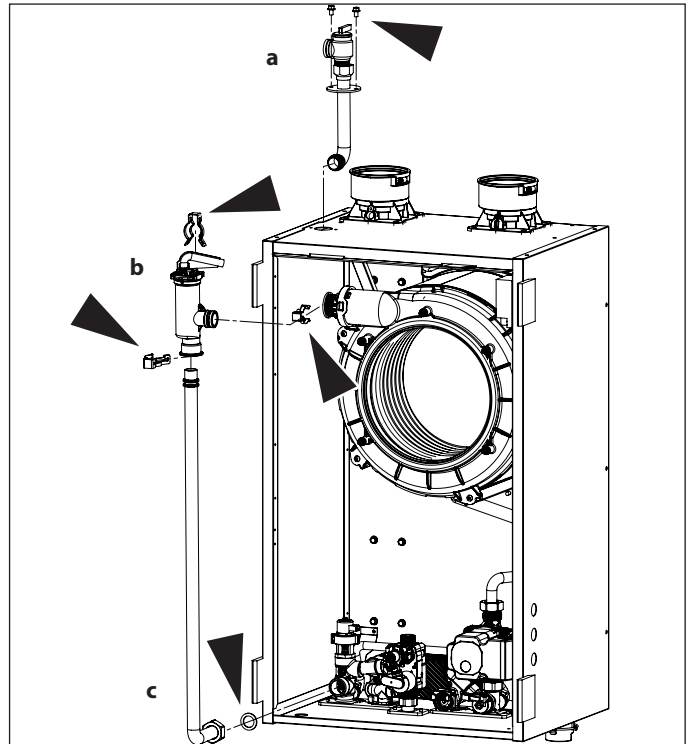

Figure 89 - Remove the CH Pressure Relief Valve and CH Outlet Pipe

6. Remove the automatic air purging device (b) from the heat exchanger.
7. Disconnect the return pipe (e) from the top of the pump, then remove the clip securing it to the heat exchanger and remove it from the boiler.

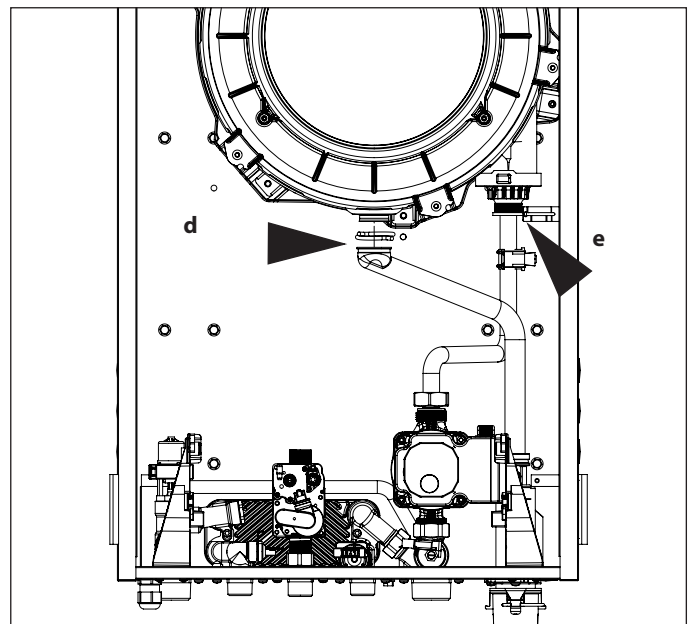

Figure 90 - Remove the Condensate Pipe and CH Return Pipe

## Part 14 - Maintenance

- Remove the six (6) fixing screws from the heat exchanger. If accessing the screws on the left part of the heat exchanger is difficult remove the lateral panel.
- Proceed in the reverse order to install the new heat exchanger.

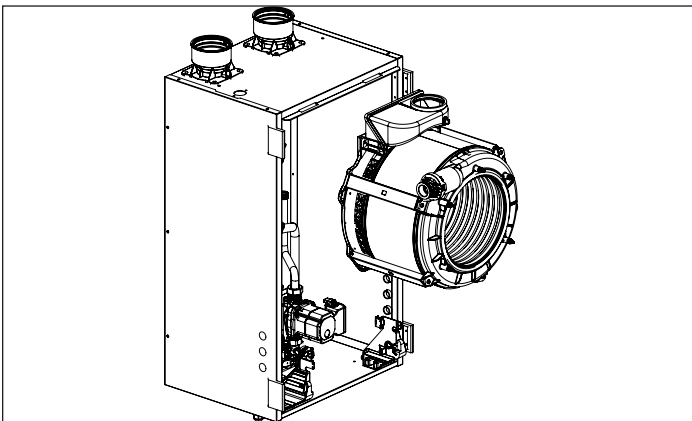
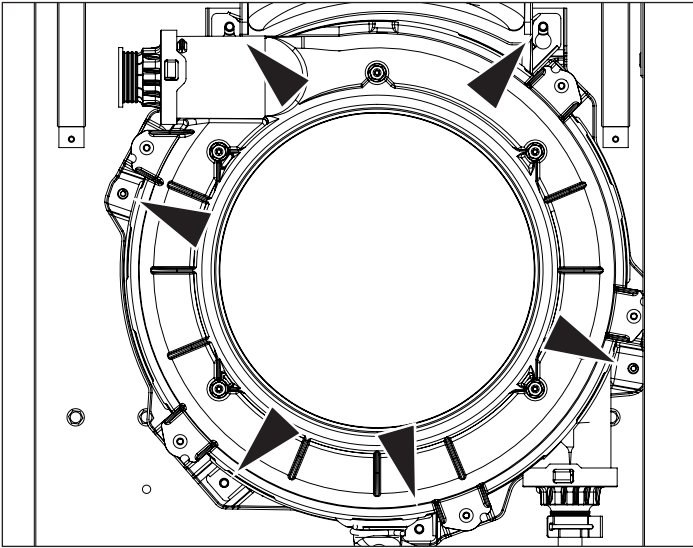

Figure 91 - Remove the Heat Exchanger

### Replacing the Gas Valve

- First remove the gas pipe as described in **Cleaning the Heat Exchanger Combustion Chamber**.
- Remove the electrical connection from the gas valve.
- Remove the two nuts above and below the gas valve. See Figure 92.

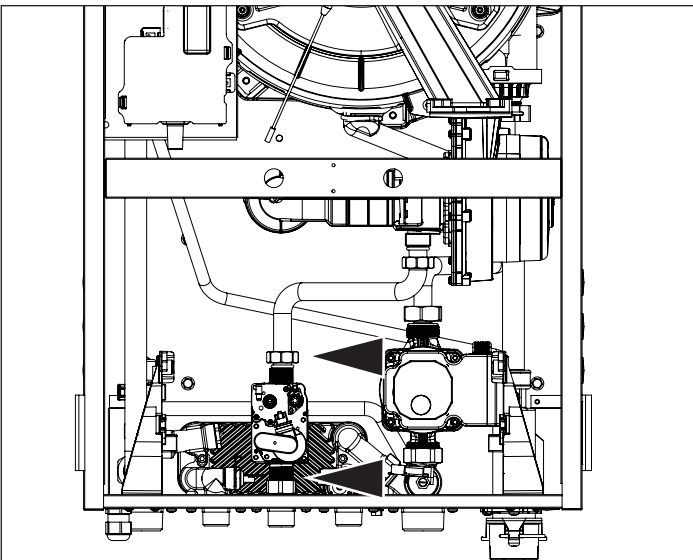

Figure 92 - Disconnect the Gas Line

- Remove the gas valve.
- Reinstall the new gas valve in reverse order.
- BE SURE TO USE NEW SEALING RINGS.**

## ! DANGER

Failure to replace the sealing rings will result in gas leaks, and could cause an explosion or fire, substantial property damage, severe personal injury, or death.

- Ensure there are no gas leaks.

### Replace the Main PCB

- Fold down the electronics box.
- Unlock the two clips and open the electronics box cover.
- Disconnect the electrical connections.
- Unhook the controller board and remove it.
- Proceed in reverse order to install the new PCB.

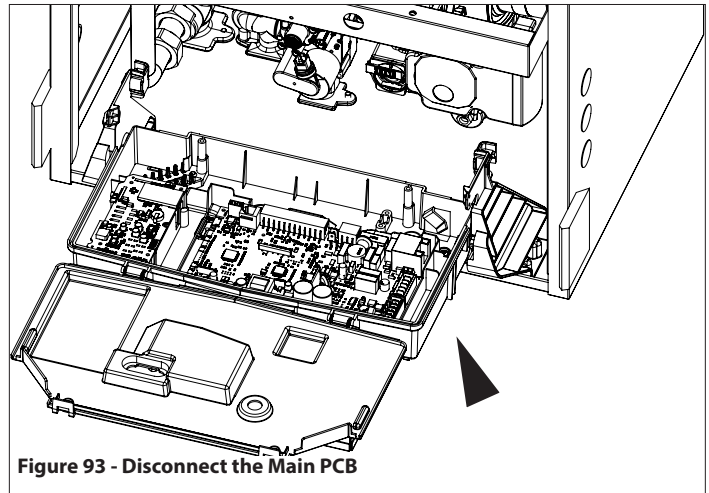

Figure 93 - Disconnect the Main PCB

- Follow the instructions provided with the replacement PCB kit for setting all necessary parameters.

## E. After Maintenance is Complete

### Functional Test

After maintenance is complete, ensure the CH circuit is filled and purged with a pressure of 12 psi. Ensure the DHW circuit is filled and purged.

- Power the boiler on.
- If necessary, purge air again from the CH and DHW circuits.
- Check the boiler and system settings and components. Ensure all adjustments are working properly.
- Ensure the exhaust pipe is connected properly.
- Reinstall the boiler front cover.
- If necessary, set the maintenance interval.

### Inform the User

- Inform the user of any changes / adjustments / replacements in the system.
- Ensure the user understands how the system works.
- Hand the instructions to the user. Ensure the instructions will be kept close to the unit.
- Have the user perform these regular tasks:
  - Check the system water pressure regularly.
  - If necessary, restore pressure and vent the system.
  - Set the setpoints and control systems to ensure correct and economical control of the system.
  - Have the system serviced in accordance with regulations at regular intervals.
  - NEVER attempt to service the boiler or adjust the combustion system.



**CAUTION**

In unusually dirty or dusty conditions, care must be taken to keep boiler cabinet door in place at all times. Failure to do so VOIDS WARRANTY!

**! WARNING**

Allowing the boiler to operate with a dirty combustion chamber will hurt operation. Failure to clean the heat exchanger as needed by the installation location could result in boiler failure, property damage, personal injury, or death. Such product failures ARE NOT covered under warranty.

The combustion chamber insulation in this product contains ceramic fiber material. Ceramic fibers can be converted to cristobalite in very high temperature applications. The International Agency for Research on Cancer (IARC) has concluded, "Crystalline silica inhaled in the form of quartz or cristobalite from occupational sources is carcinogenic to humans (Group 1)."

- Avoid breathing dust and contact with skin and eyes.
- Use a NIOSH certified dust respirator (N95). This type of respirator is based on the OSHA requirements for cristobalite at the time this document was written. Other types of respirators may be needed depending on job site conditions. Current NIOSH recommendations can be found on the NIOSH website: <http://www.cdc.gov/niosh/homepage.html>. NIOSH approved respirators, manufacturers, and phone numbers are also listed on this website.
- Wear long-sleeved, loose fitting clothing, gloves, and eye protection.
- Apply enough water to the combustion chamber lining to prevent dust.
- Wash potentially contaminated clothes separately from other clothing. Rinse clothes washer thoroughly.

NIOSH stated First Aid.

- Eye: Irrigate immediately.
- Breathing: Fresh air.

The boiler requires minimal periodic maintenance under normal conditions. However, in unusually dirty or dusty conditions, periodic vacuuming of the cover to maintain visibility of the display and indicators is recommended.

Periodic maintenance should be performed once a year by a qualified service technician to ensure that all the equipment is operating safely and efficiently. The owner should make necessary arrangements with a qualified heating contractor for periodic maintenance of the boiler. Installer must also inform the owner that the lack of proper care and maintenance of the boiler may result in a hazardous condition.

## Part 15 - Maintenance Report

INSPECTION ACTIVITIES		DATE LAST COMPLETED			
		1st YEAR	2nd YEAR	3rd YEAR	4th YEAR*
<b>PIPING</b>					
Near boiler piping	Check boiler and system piping for any sign of leakage. Leaking pipes could cause property damage. Make sure all piping is properly supported. See User's Information manual for instructions.				
Vent	Check condition of all vent pipes and joints. Ensure all vent piping is properly supported. Check for obstructions at exhaust and intake termination points.				
Gas	Check Gas piping, test for leaks and signs of aging. Make sure all pipes are properly supported.				
<b>SYSTEM</b>					
Visual	Do a full visual inspection of all system components.				
Functional	Test all functions of the system (central heat, water heating, Safeties)				
Temperatures	Verify safe settings on boiler or Anti-Scald Valve				
Temperatures	Verify programmed temperature settings				
<b>ELECTRICAL</b>					
Connections	Check wire connections. Make sure they are tight.				
Smoke and CO detector	Verify devices are installed and working properly. Change batteries if necessary.				
Circuit Breakers	Ensure the circuit breaker is clearly labeled. Exercise circuit breaker.				
Switch and Plug	Verify ON/OFF switch and convenience plug are both functional				
<b>CHAMBER/BURNER</b>					
Combustion Chamber	Check burner tube and combustion chamber coils. Clean according to maintenance section of manual. Vacuum combustion chamber.				
Spark Electrode	Clean. Set gap at 1/8".				
<b>CONDENSATE</b>					
Condensate Trap	Clean debris from the condensate trap. Fill with clean water.				
Neutralizer	Check condensate neutralizer. Replace if necessary.				
Condensate hose	Disconnect condensate hose. Clean out dirt and re-install. <b>(NOTE: Verify the flow of condensate, making sure that the hose is properly connected during final inspection.)</b>				
<b>GAS</b>					
Pressure	Measure incoming gas pressure (3.5 to 10.5" W.C. NG, 8 to 13" W.C. LP)				
Pressure Drop	Measure drop in pressure on light off (no more than 1" W.C.)				
Check for leaks	Check gas piping for leaks. Verify that all are properly supported.				
<b>COMBUSTION</b>					
CO/CO2 Levels	Check CO and CO2 levels in Exhaust. Record at high and low fire.				
<b>SAFETIES</b>					
ECO (Energy Cut Out)	Check continuity on flue temperature sensor. Replace the flue gas temperature sensor if corroded. Check continuity on Water ECO. Check position and sensor resistance. Ensure air pressure switch is properly connected (electrical connections and silicone pipe).				
<b>DHW LOOP - Combi Models</b>					
	It is recommended to flush the DHW heat exchanger annually if water hardness exceeds 12 grains per gallon (considered extremely hard water). If water hardness falls below 12 grains per gallon it is recommended to flush the heat exchanger every two to three years. It is also recommended to clean the CH and DHW inlet filters annually.				
<b>FINAL INSPECTION</b>					
Check list	Verify that you have completed entire check list. WARNING: FAILURE TO DO SO COULD RESULT IN SERIOUS INJURY OR DEATH.				
Homeowner	Review what you have done with the homeowner.				
<b>TECH SIGN OFF</b>					

Table 35 - \*Continue annual maintenance beyond the 4th year as required.

**A. Shutdown Procedure**

Turn the boiler off at the on/off power switch. Wait for the combustion blower to stop, so all latent combustion gases are purged from the system. This could take a maximum of 5 minutes.

**B. Failure to Operate**

Should the burner fail to light, the control will perform four more ignition trials prior to entering a lockout state. Note that each subsequent ignition trial will not occur immediately. After a failed ignition trial, the blower must run for approximately 5 seconds to purge the system.

If the burner lights during any one of these five ignition trails, normal operation will resume.

If the burner does not light after the fifth ignition trial, the control will enter a lockout state.

This lockout state indicates that a problem exists with the boiler, the controls, or the gas supply.

Under such circumstances, a qualified service technician should be contacted immediately to properly service the boiler and correct the problem. If a technician is not available, press a button on the display to wake it. Then press the RESET button to remove the lockout state so additional trials for ignition can be performed.

If the RESET key is not pressed (error code 501 or 503), the boiler will reset automatically after an hour.

**C. Important**

**! WARNING**

It is extremely important that whenever work is performed on the plumbing system that either:

- The appliance is powered off, and,
- The area that is being worked on is valved off and isolated.

Failure to take these measures could result in a dry-firing condition, explosion or fire, substantial property damage, severe personal injury, or death.

Outdoor Sensor		Supply/Return Temperature Sensors Tank Sensor DHW Outlet Sensor	
Outside Temperature (°F)	Resistance (ohms)	Water Temp. (°F)	Resistance (Ohms)
-22	178605	32	27219
-13	132045	41	22021
-4	98438	50	17926
5	73995	59	14674
14	56079	68	12081
23	42846	77	10000
32	32997	86	8315
41	25609	95	6948
50	20027	104	5834
59	15777	113	4917
68	12517	122	4161
77	10000	131	3535
86	8042	140	3014
95	6510	149	2586
104	5302	158	2228
113	4343	167	1925
		176	1669
		185	1452
		194	1268
		202	1110
		212	974

**Table 36 - Sensor Temperature Resistance**



**Customer Installation Record Form**

The following form should be completed by the qualified installer / service technician for you to keep as a record of the installation in case of a warranty claim. After reading the important notes at the bottom of the page, please also sign this document.

Customer's Name	
Date of Installation	
Installation Address	
Product Name / Serial Number(s)	
Comments	
Installer's Code / Name	
Installers Phone Number	
Signed by Installer	
Signed by Customer	
Installation Notes	

**IMPORTANT**

Customer: Please only sign after the qualified installer / service technician has fully reviewed the installation, safety, proper operation, and maintenance of the system. If the system has any problems please call the qualified installer / service technician. If you are unable to make contact, please call your sales representative.

Distributor / Dealer: Please insert contact details.



Visit us online

**NTI Boilers Inc.**

30 Stonegate Drive Saint John,  
NB E2H 0A4 Canada  
Technical Assistance: 1-800-688-2575  
Website: [www.ntiboilers.com](http://www.ntiboilers.com)  
Fax: 1-506-432-1135

