

# HALSEY TAYLOR OWNERS MANUAL

## *OVL™ Series Barrier-Free Water Coolers Refrigerated Fountains with Back Panel*



Figure 1 – OVL-II ER-Q



Figure 2 – OVL-II SR-Q



Figure 3 – OVLII SER-Q



Figure 4 – OVL-II ESR-Q

| Figure | Model        | Description                       |
|--------|--------------|-----------------------------------|
| 1      | OVL-II ER-Q  | OVL-II Series - Extended Reach    |
| 2      | OVL-II SR-Q  | OVL-II Series - Standard Reach    |
| 3      | OVL-II SER-Q | OVL-II Series - Dual Installation |
| 4      | OVL-II ESR-Q | OVL-II Series - Dual Installation |

### INSTALLER

**CAUTION:** Review these instructions before beginning installation. Be sure that installation conforms to all plumbing, electrical and other applicable codes.

**WARNING:** When installation is complete, ensure these instructions are left in the plastic bag provided inside the installed unit for future reference.

**WARNING:** Service to be performed by authorized service personnel only.

**NOTE:** It is common practice to ground electrical hardware such as telephones, computers and other devices to available water lines. This can, however, cause electrical feedback in the plumbing circuit, which results in an “electrolysis” effect occurring in the fountain. This may result in water which has a metallic taste to it or has a noticeable increase in the metallic content of the water.

When inspecting plumbing circuit, remember the line may be grounded some distance from the installation, and may occur outside the building or area in which the unit is being installed.

This condition can be avoided (in most cases) by using recommended materials during installation. Any drain fittings provided by the installer should be made of **plastic** which will electronically isolate the fountain from the remainder of the building’s plumbing circuits.

OVLERQ\*D OVLSRQ\*D OVLESRQ\*G OVLSERQ\*G

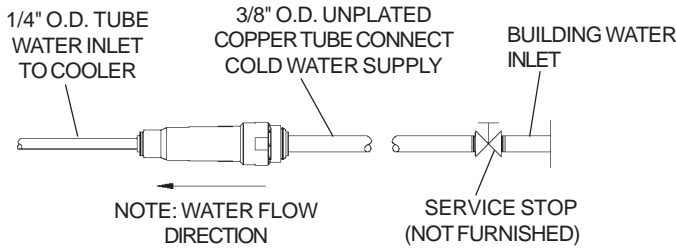

Figure 5 – Water Supply Connections

**Installation Package**

The components for installation are packed in three separate boxes, regardless of the type of unit being installed. The boxes contain the following:

- Box No. 1: Wall Frame(s)
- Box No. 2: Remote Chiller, SJ8-Q
- Box No. 3: Fountain(s), Arm(s) and Panels

Additional materials, as noted in the Parts List, are also shipped in these boxes.

**Parts List** **Number Required**

| Item | Part No.     | Description                           | OVL-II ER-Q | OVL-II SR-Q | OVL-II SER-Q | OVL-II ESR-Q | See Fig. |
|------|--------------|---------------------------------------|-------------|-------------|--------------|--------------|----------|
| 1    | 26990C       | Bottom Cover - Standard Reach         | -           | 1           | 1            | 1            | 23       |
|      | 26988C       | Bottom Cover - Extended Reach         | 1           | -           | 1            | 1            | 23       |
| 2    | 55836C       | Push Arm Actuator                     | 1           | 1           | 2            | 2            | 20       |
|      | 55991C       | Push Arm Actuator - A.G.              | 1           | 1           | 2            | 2            | 20       |
| 3    | 51546C       | Bubbler - S.S.                        | 1           | 1           | 2            | 2            | 23       |
|      | 45396C       | Bubbler - A.G.                        | 1           | 1           | 2            | 2            | 23       |
|      |              | Bubbler - EasyFlex (option)           | 1           | 1           | 2            | 2            | -        |
| 4    | 100322740560 | Bubbler Gasket                        | 2           | 2           | 4            | 4            | 23       |
| 5    | 160270508640 | Strainer Plate - S.S.                 | 1           | 1           | 2            | 2            | 23       |
|      | 45400C       | Strainer Plate - A.G.                 | 1           | 1           | 2            | 2            | 23       |
| 6    | 101570540560 | Drain Gasket                          | 1           | 1           | 2            | 2            | 23       |
| 7    | 51575C       | Packing Ring                          | 1           | 1           | 2            | 2            | 23       |
| 8    | 110346220550 | Drain Nut                             | 2           | 2           | 4            | 4            | 23       |
| 9    | 101637451550 | Friction Ring                         | 1           | 1           | 2            | 2            | 23       |
| 10   | 161637308640 | Drain Plug - S.S.                     | 1           | 1           | 2            | 2            | 23       |
|      | 45398C       | Drain Plug - A.G.                     | 1           | 1           | 2            | 2            | 23       |
| 11   | 45683C       | Drain Tube                            | 1           | -           | 1            | 1            | 23       |
|      | 45682C       | Drain Tube                            | -           | 1           | 1            | 1            | 23       |
| 12   | 100023340560 | Waste Tube Gasket                     | 1           | 1           | 2            | 2            | 23       |
| 13   | 161570808550 | Slip Nut                              | 1           | 1           | 2            | 2            | 23       |
| 14   | 61314C       | Regulator                             | 1           | 1           | 2            | 2            | 22       |
| 15   | 50986C       | Regulator Holder                      | 1           | 1           | 2            | 2            | 22       |
| 16   | 27006C       | Basin - S.S.                          | 1           | 1           | 2            | 2            | 23       |
|      | 27342C       | Basin - A.G.                          | 1           | 1           | 2            | 2            | 23       |
|      |              | Basin - Galaxy Gray Marblyte (option) | 1           | 1           | 2            | 2            | -        |
|      |              | Basin - Golden Sand Marblyte (option) | 1           | 1           | 2            | 2            | -        |
|      |              | Basin - Black Onyx Marblyte (option)  | 1           | 1           | 2            | 2            | -        |
| 17   | 27000C       | Basin Liner - S.S.                    | 1           | 1           | 2            | 2            | 23       |
|      | 27344C       | Basin Liner - A.G.                    | 1           | 1           | 2            | 2            | 23       |
| 18   | 70861C       | Screw - #10-24 X 2.00                 | 4           | 4           | 8            | 8            | 23       |
| 19   | 55840C       | Top Plate - Actuator                  | 1           | 1           | 2            | 2            | 20       |
| 20   | 55839C       | Bottom Plate - Actuator               | 1           | 1           | 2            | 2            | 20       |
| 21   | 27002C       | Extended Reach Arm - S.S.             | 1           | -           | 1            | 1            | 23       |
|      | 27338C       | Extended Reach Arm - A.G.             | 1           | -           | 1            | 1            | 23       |
|      | 27004C       | Standard Reach Arm - S.S.             | -           | 1           | 1            | 1            | 23       |
|      | 27340C       | Standard Reach Arm - A.G.             | -           | 1           | 1            | 1            | 23       |
| 22   | 28328C       | Regulator Mounting Bracket            | 1           | 1           | 2            | 2            | 21       |
| 23   | 15005C       | Nut - Retaining                       | 1           | 1           | 2            | 2            | 22       |
| 24   | 40045C       | Hex Nut - Unplated                    | 1           | 1           | 2            | 2            | 22       |

OVLERQ\*D OVLSRQ\*D OVLESRQ\*G OVLSESRQ\*G

Parts List Continued

| Item | Part No. | Description                         | OVL-II<br>ER-Q | OVL-II<br>SR-Q | OVL-II<br>SER-Q | OVL-II<br>ESR-Q | See<br>Fig. |
|------|----------|-------------------------------------|----------------|----------------|-----------------|-----------------|-------------|
| 25   | 27008C   | Reaction Bracket                    | 1              | 1              | 2               | 2               | 21          |
| 26   | 70856C   | Screw - #10-24 x .38 PHMS           | 1              | 1              | 2               | 2               | 21          |
| 27   | 70854C   | Rod - Pivot                         | 1              | 1              | 2               | 2               | 21          |
| 28   | 50198C   | Bushing Snap                        | 4              | 4              | 8               | 8               | 21          |
| 29   | 51667C   | Bumper - Regulator Valve Assy       | 1              | 1              | 2               | 2               | 21          |
| 30   | 28327C   | Arm - Regulator Activating          | 1              | 1              | 2               | 2               | 21          |
| 31   | 28326C   | Arm - Regulator Adjustment          | 1              | 1              | 2               | 2               | 21          |
| 32   | 22797C   | Upper Panel (OVL-II ER) - S.S.      | 1              | -              | -               | -               | 13, 23      |
|      | 27886C   | Upper Panel (OVL-II ER) - A.G.      | 1              | -              | -               | -               | 13, 23      |
|      | 22799C   | Upper Panel (OVL-II SR) - S.S.      | -              | 1              | -               | -               | 13, 23      |
|      | 27888C   | Upper Panel (OVL-II SR) - A.G.      | -              | 1              | -               | -               | 13, 23      |
|      | 26958C   | Upper Panel (OVL-II SER) - S.S.     | -              | -              | 1               | -               | 13, 23      |
|      | 27890C   | Upper Panel (OVL-II SER) - A.G.     | -              | -              | 1               | -               | 13, 23      |
|      | 22795C   | Upper Panel (OVL-II ESR) - S.S.     | -              | -              | -               | 1               | 13, 23      |
|      | 27892C   | Upper Panel (OVL-II ESR) - A.G.     | -              | -              | -               | 1               | 13, 23      |
| 33   | 26833C   | Lower Panel (OVL-II ER/SR) - S.S.   | 1              | 1              | -               | -               | 15, 23      |
|      | 27894C   | Lower Panel (OVL-II ER/SR) - A.G.   | 1              | 1              | -               | -               | 15, 23      |
|      | 27026C   | Lower Panel (OVL-II SER/ESR) - S.S. | -              | -              | 1               | 1               | 15, 23      |
|      | 27896C   | Lower Panel (OVL-II SER/ESR) - A.G. | -              | -              | 1               | 1               | 15, 23      |
| 34   | 55996C   | Strainer (Supplied with Chiller)    | 1              | 1              | 1               | 1               | 17, 18      |
| 35   | 70683C   | Union - 1/4"                        | 1              | 1              | -               | -               | 17          |
| 36   | 70682C   | Tee - 1/4"                          | -              | -              | 1               | 1               | 18          |
| 37   | 56092C   | Poly Tubing - 1/4" (Cut To Length)  | 1              | 1              | 1               | 1               | 17, 18      |
| N-S  | 56159C   | Bubbler Nipple Assembly             | 1              | 1              | 2               | 2               | -           |

NOTE: S.S. means Stainless Steel  
A.G. means Aztec Gold  
N-S means not shown

OVLERQ\*D OVLSRQ\*D OVLESRQ\*G OVLSERQ\*G

Models

OVL-II SER-Q – OVL-II ESR-Q

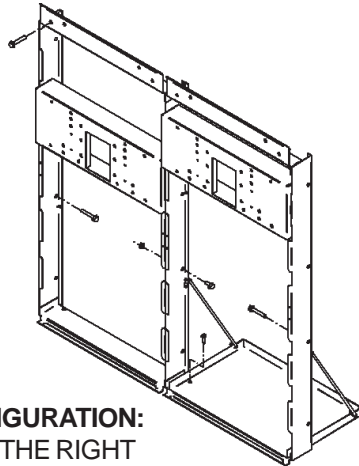

Figure 6 – OVL-II SER-Q Rough-In

1. **Cut a rectangular wall opening** 37-1/2" (953 mm) W x 37-3/4" H (959 mm) and 4-1/2" (114 mm) above the floor line (see Figure 7). The dimensions are required to obtain proper rim and bubbler heights for compliance with ANSI standard A117.1.
2. **Reinforce the wall opening** on all sides to adequately support the water fountain. This reinforcement must support up to 150 lbs. static load and provide a means for securing the frame assembly in place.  
**NOTE:** Building construction must allow for adequate air flow on both sides and top of remote chiller unit a minimum of 4" (102 mm) is required.
3. **Install plumbing and electrical rough-ins.** A junction box for a (3) wire, 10 amp branch circuit is provided on the inside of the chiller. (Standard 120 Volts, 60 Hz, and single phase.)
4. **Remove frames and related hardware** from packaging. Release the two shelf rods by cutting cable ties. Attach the two frames together through the upright supports with (4) 5/16" x 3/4" (19 mm) long bolts and nuts (provided). Tighten securely.

**MAKE SURE FRAME CONFIGURATION MATCHES THE COOLER TO BE INSTALLED**

**REVERSED CONFIGURATION:  
HIGHER UNIT ON THE RIGHT**



5/16" SCREWS OR BOLTS  
(12 REQ'D-NOT FURNISHED)

FRAME

5/16" HEX NUT  
(4 REQ'D - PROVIDED)  
P/N 111577343890

SCREWS OR BOLTS  
(NOT PROVIDED)

INSTALL (3) SCREWS  
(P/N 111008343890) IN FRAME  
BEFORE INSTALLING IN OPENING

HOOK RODS (2)  
P/N 101567443730

**STANDARD CONFIGURATION:  
HIGHER UNIT ON THE LEFT**

BOLT FRAMES TOGETHER  
WITH 5/16" X 3/4" (19mm) BOLTS  
(4 REQ'D-PROVIDED)  
P/N 111577243890

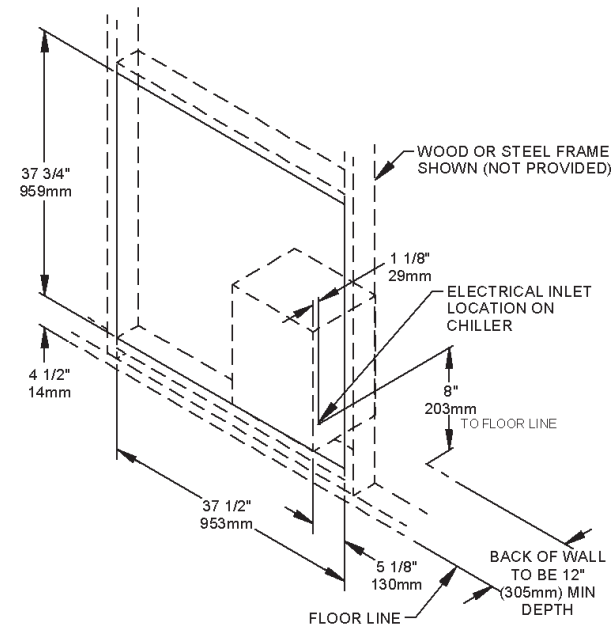

Figure 7 – Rough-In Assembly  
Dual-Station Mounting Frames

OVLERQ\*D OVLSRQ\*D OVLESRQ\*G OVLSERQ\*G

5. **Install the frame assembly squarely in wall opening** with frame upright support edges flush with the finished wall face. Secure the frame to the wall through holes with (12) 5/16" bolts or screws (not provided). Tighten securely.

**NOTE:** Be sure that frame is squared in location. Do not use less than required screw quantity and size.

6. **Attach the chiller shelf support rods** to the right side of the frame uprights at the second set of holes counting from the bottom and to the shelf at the (2) side holes. Line up the other shelf holes with the frame bottom holes and fasten the assembly to the wall opening using appropriately sized screws or bolts and nuts (not provided).

**MODEL OVL-SER SHOWN**

**MODEL OVL-ESR**

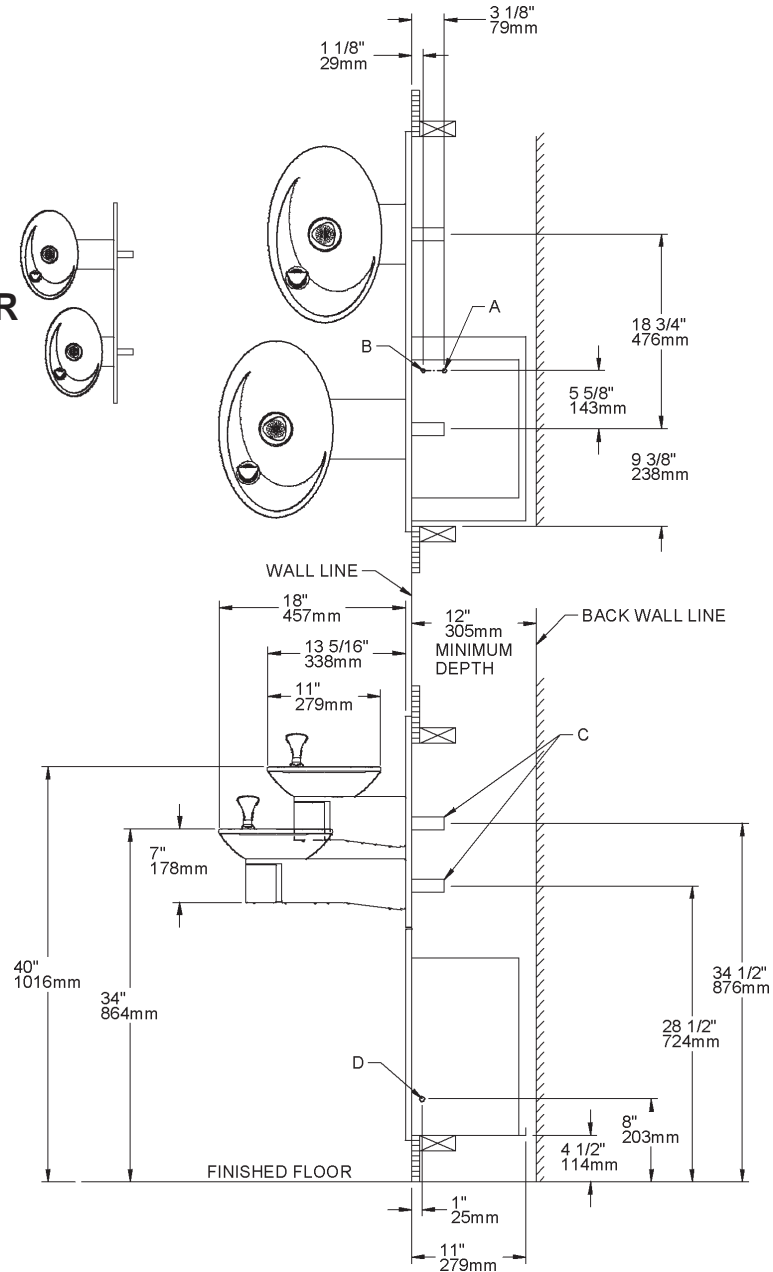

**Legend**

| Item | Description                              |
|------|--|
| A    | 1/4" O.D. Tube - Water Outlet Connection |
| B    | 3/8" O.D. Tube - Water Inlet Connection  |
| C    | 1-1/4" O.D. Waste Tube                   |
| D    | Electrical Inlet on Chiller              |

Figure 8 – OVL-II SER-Q/OVL-II ESR-Q Rough-In Dimensions

OVLERQ\*D OVLSRQ\*D OVLESRQ\*G OVLSERQ\*G  
 Models  
 OVL-II ER-Q – OVL-II SR-Q



Figure 9 – OVL-II ER-Q/OVL-II SR-Q Rough-In

1. **Cut a rectangular wall opening** 18-3/4" (475 mm) W x 37-3/4" H (959 mm) and 4-1/2" (114 mm) above the floor line (see Figure 10). The dimensions are required to obtain proper rim and bubbler heights for compliance with ANSI standard A117.1.
2. **Reinforce the wall opening** on all sides to adequately support the water fountain. This reinforcement must support up to 150 lbs. static load and provide a means for securing the frame assembly in place.  
**NOTE:** Building construction must allow for adequate air flow on both sides and top of remote chiller unit. Minimum of 4" (102 mm) is required.
3. **Install plumbing and electrical rough-ins.** A junction box for a (3) wire, 10 amp branch circuit is provided on the inside of the chiller. (Standard 120 Volts, 60 Hz, and single phase.)
4. **Remove frame and related hardware** from packaging. Release the two shelf rods by cutting cable ties.

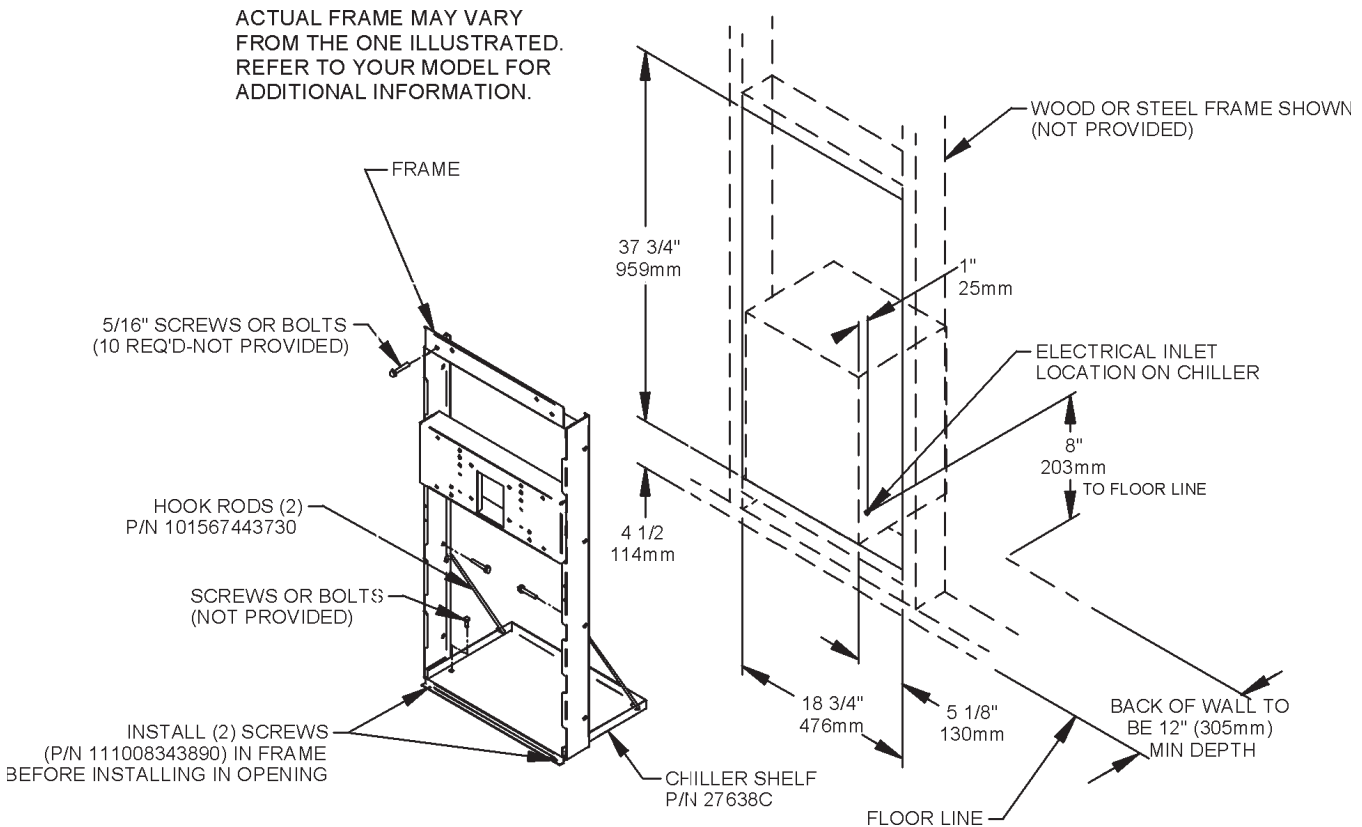

Figure 10 – Rough-In Assembly  
 Single-Station Mounting Frames

OVLERQ\*D OVLSRQ\*D OVLESRQ\*G OVLSERQ\*G

5. **Install the frame squarely in wall** opening with frame upright edges flush with the finished wall surface. Place shelf inside frame and line up the (2) holes on each. Insert loose ends of rods into holes on sides of shelf panel. Using appropriately sized screws or bolts

(not provided), fasten the shelf and frame to the bottom of wall opening. Secure the frame sides and top to the wall opening using (10) 5/16" bolts or screws (not provided).

**NOTE:** Be sure that frame is squared in location. Do not use less than the required screw quantity and size.

**MODEL OVL-ER**

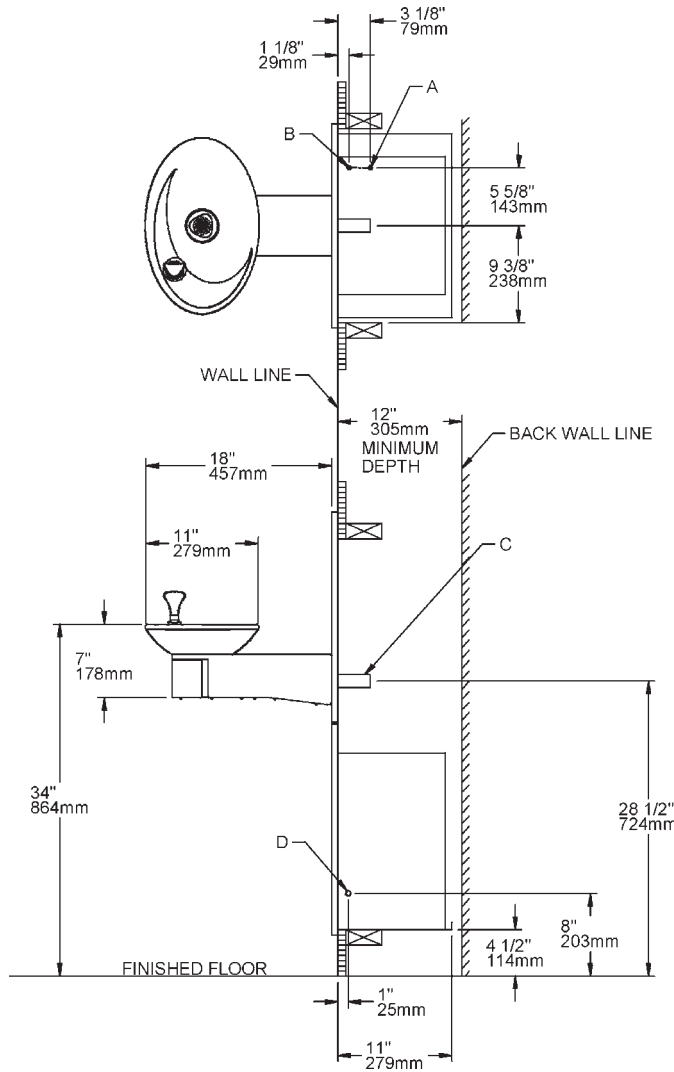

**MODEL OVL-SR**

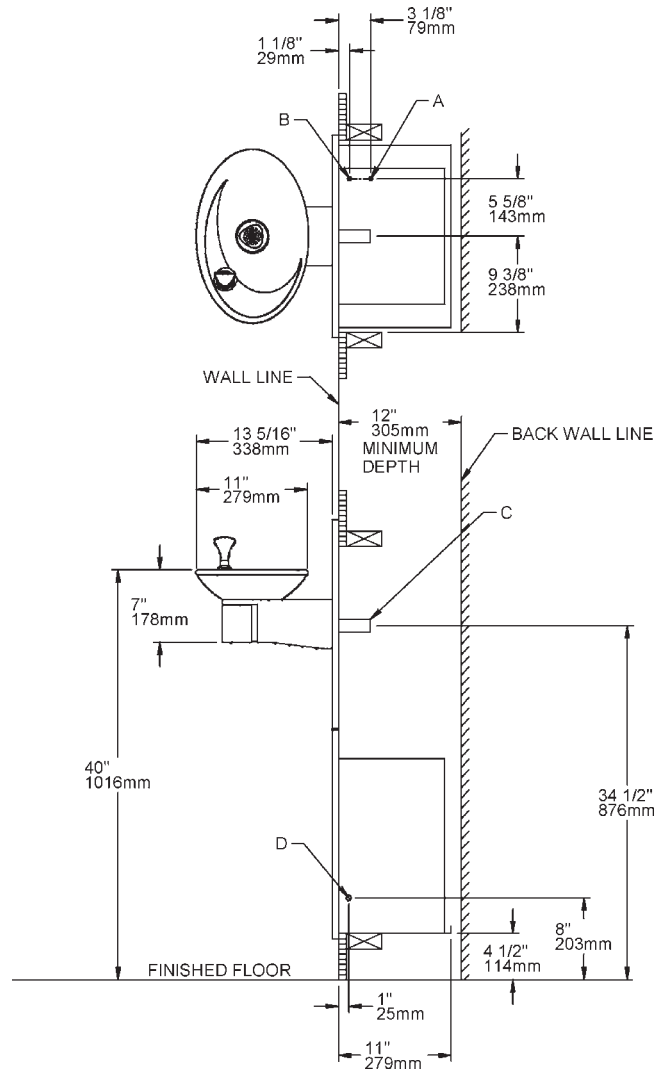

**Legend**

| Item | Description                              |
|------|--|
| A    | 1/4" O.D. Tube - Water Outlet Connection |
| B    | 3/8" O.D. Tube - Water Inlet Connection  |
| C    | 1-1/4" O.D. Waste Tube                   |
| D    | Electrical Inlet on Chiller              |

Figure 11 – OVL-II ER-Q/SR-Q Rough-In Dimensions



**REQUIRED TOOLS AND MATERIALS**

These tables show special tools and/or additional materials (not provided) which are necessary to complete installation of these units:

**Special Tools**

| Item | Description | Quantity |
|------|-------------|----------|
|      | NONE        |          |

**Additional Materials**

| Item | Description                | Quantity |
|------|----------------------------|----------|
| 1    | Unplated copper inlet pipe |          |
| 2    | Service Stop               |          |

**OVL-II ER-Q/SR-Q/SER-Q/ESR-Q INSTALLATION**

1. **Assemble and** place frame in wall as shown on preceding pages.
2. **Install chiller:** Remove front panel of chiller. **Remove and discard cardboard inner pack from between compressor and side panel.** Slide chiller onto the shelf and position it to the left within the guides on the shelf.

**NOTE:** Building construction must allow for adequate air flow on both sides, top and back of chiller. A minimum of 4" (102mm) on both sides and top is required. See chiller installation for additional instructions.



Figure 12 – Chiller Installation

3. **Make water supply connections.** Inlet port is marked on the chiller (1/4" O.D. copper tube). Bend the copper tube (provided) at an appropriate length from the chiller to opening in frame. Install the in-line strainer (provided with chiller) by pushing it in until it reaches a positive stop, approximately 3/4" (19mm) on the marked chiller inlet port. Attach an unplated and deburred copper water inlet line and a service stop (not provided) to the chiller. Turn on the water supply and flush the line thoroughly.
4. **Hang the upper panel on the mounting frame hanger.** Align holes in the panel with the holes in the mounting frame. Be sure that panel is engaged with hanger at top of frame before releasing it.

5. **Install fountain.** Remove access cover plate on underside of fountains and **SAVE** the screws. Mount the fountains to the upper panel and frame with (4) 5/16" x 3/4" (19mm) long bolts and nuts provided. Tighten securely.



Figure 13 – Upper Panel Installation

**Note:** With OVL-II SER-Q or OVL-II ESR-Q models, the standard reach fountain must be mounted at the upper position on panel.



Figure 14 – Fountain Installation

6. **Connect the fountain drain waste tube to the building sanitary sewer system.** Connection should be made in compliance with local plumbing code requirements. (Note: Plumbing trap is not included with the fountain).
7. **Make connection between remote chiller outlet tube and fountain(s).** Outlet port is marked on the chiller (1/4" O.D. copper tube). Install a 1/4" union/tee (provided) on the marked chiller outlet port. Insert the 1/4" poly tubing coming from the fountain(s) into the union/tee. Turn on water supply and check for leaks.



**CAUTION:** DO NOT SOLDER tubes while inserted into the strainer as damage to o-rings may result.

8. **These products are designed to operate on 20-105 PSIG supply line pressure.** If inlet pressure is above 105 PSIG, a pressure regulator must be installed in the supply line.

**CAUTION:** Any damage caused by connecting these products to a supply line with pressure lower than 20 PSIG or higher than 105 PSIG IS NOT covered under warranty.

9. **Make electrical connections to the chiller.** See chiller instructions.
10. **Check stream height from bubbler.** Stream height is factory set at 35-40 PSI. If supply pressure varies greatly from this, remove items 2, 19, and 20 (push arm and the bottom and the top actuator plates – Figure 20) by removing the screws holding assembly together and adjust the screw on the regulator (Item 14 – Figs. 21& 22). Clockwise adjustment will raise stream height and counterclockwise movement will lower stream height. For best adjustment, stream height should be approximately 1-1/2" (38mm) above the bubbler guard. (See Figure 16).
11. **Mount lower panel.** Loosen the two (2) #10-24 x 5/8" (16mm) screws at frame bottom lip. Slide upper tongue of lower panel under lower edge of already installed upper panel. Tighten previously loosened screws securely.
12. **Replace bottom access panel** to fountain basin using screws provided. Tighten securely.



Figure 15 – Lower Panel Installation

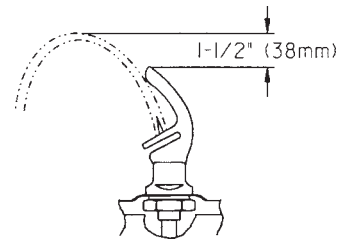

Figure 16 – Stream Height

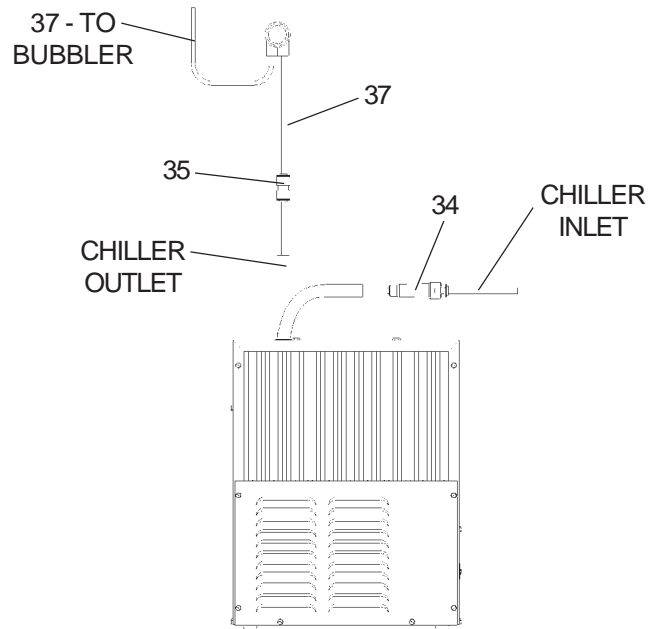

Figure 17 – OVL-II ER-Q/SR-Q Tube Routing

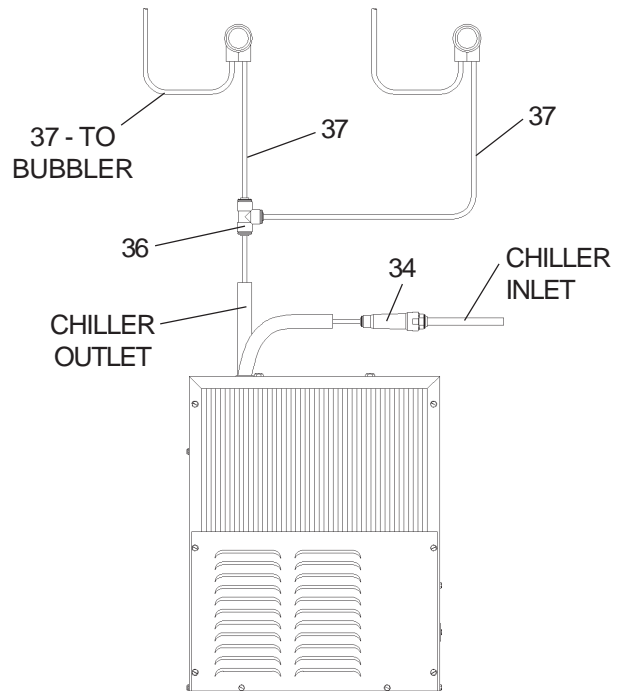

Figure 18 – OVL-II SER-Q/ESR-Q Tube Routing

**TROUBLESHOOTING & MAINTENANCE**

**Orifice Assembly:** Mineral deposits on orifice can cause water flow to spurt or not regulate. Mineral deposits may be removed from the orifice by poking with a small round file not over 1/8" diameter, or using a small diameter wire.

**CAUTION:** DO NOT file or cut orifice material.

**Stream Regulator:** If orifice is clean, regulate flow as in Step 10 of the installation instructions. If replacement is necessary, see parts list for correct regulator part number.

**CAUTION:** To preserve the quality and keep this AZTEC GOLD finish clean and spot free, clean this surface with only mild detergent or window cleaner and polish with a soft cloth. DO NOT use any abrasive cleaners or harsh chemicals. They WILL damage the finish!

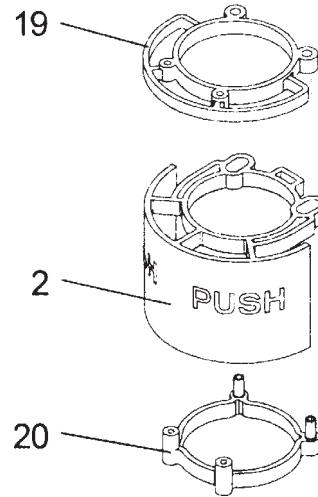

Figure 20 – Push Arm Mechanism

**Actuation of Quick Connect Water Fittings:** Cooler is provided with lead-free connectors which utilize an o-ring water seal. To remove tubing from the fitting, relieve water pressure, push in on the gray collar while pulling on the tubing. (See Figure 19) To insert tubing, push tube straight into fitting until it reaches a positive stop (approximately 3/4").

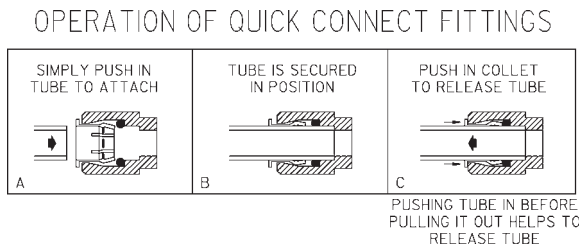

Figure 19 – Quick Connect Fittings

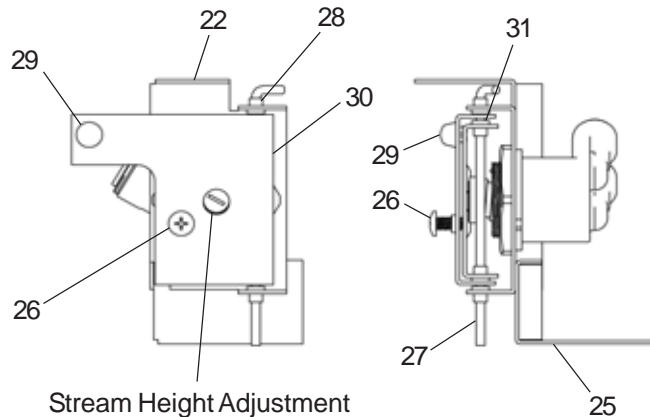

Figure 21 – Regulator Mounting Mechanism

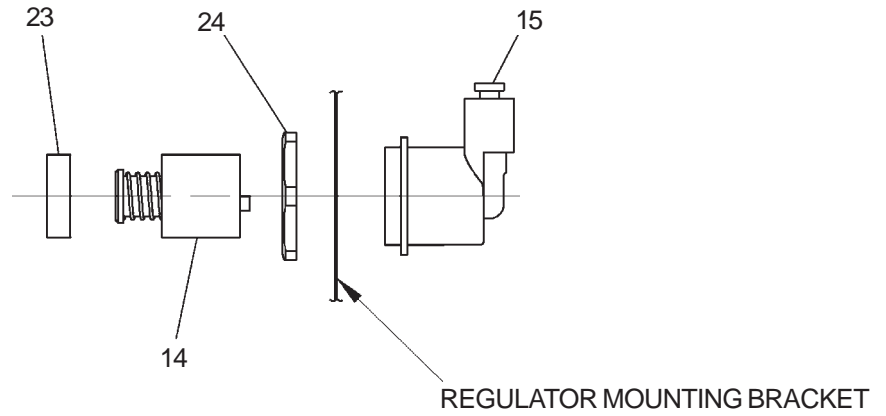

Figure 22 – Regulator Assembly

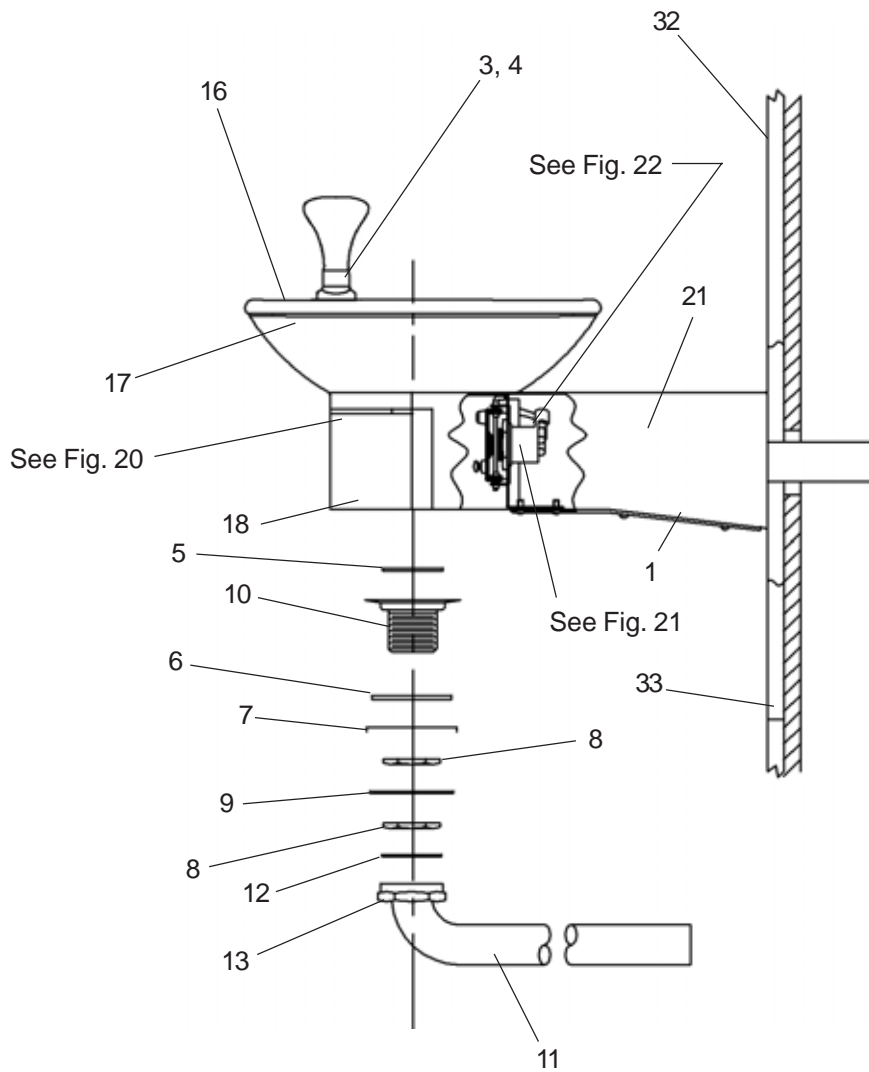

Figure 23 – Fountain Assembly - Side View

OVLERQ\*D OVLSRQ\*D OVLESRQ\*G OVLSERQ\*G

***Halsey Taylor***<sup>®</sup>  
2222 CAMDEN COURT  
OAK BROOK, IL 60523  
630.574.3500

PRINTED IN U.S.A.

FOR PARTS CONTACT YOUR LOCAL DISTRIBUTOR OR VISIT OUR WEBSITE [WWW.HALSEYTAYLOR.COM](http://WWW.HALSEYTAYLOR.COM)

97881C - (Rev. E - 4/07)