

INSTALLATION GUIDE

GB1-CT 15 GPM Super-Capacity Grease Interceptor for Indoor Use

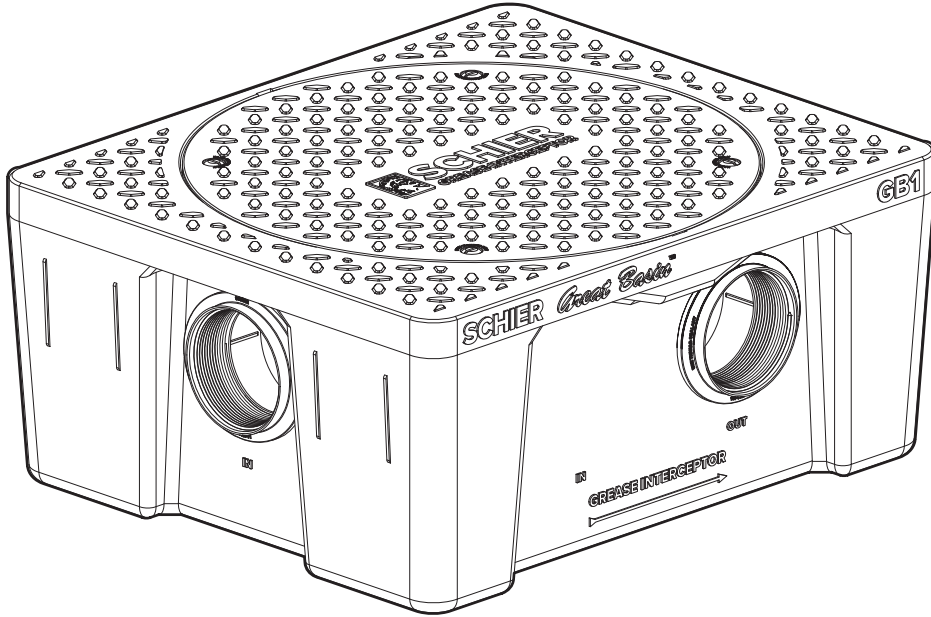

Contents

Special Precautions	2
Getting to Know the GB1-CT	3
On the Floor Installation	4-6
Buried Installation	7-9



SCHIER
LIFETIME GUARANTEED
GREASE INTERCEPTORS



SPECIAL PRECAUTIONS

For Schier Grease Interceptor Installations - Failure to follow this guidance voids your warranty

WARNING! DO NOT AIR TEST UNIT OR RISER SYSTEM!
Doing so may result in property damage, personal injury or death.

CAUTION! Do not install this unit in any manner except as described in these instructions.

Installation Instructions

Installation instructions and additional components are included with the interceptor. Read all instructions prior to installation. This interceptor is intended to be installed by a licensed plumber in conformance with all local codes.

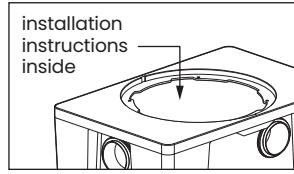

When Installing Interceptor Inside

If your dishwashing sink(s) discharges into a floor drain/sink (drain), you must regulate the flow into the drain to avoid an overflow of water onto the kitchen floor. This can be done by installing a valve or flow restriction cap on the sink piping that discharges into the drain. See drawing for guidance. For detailed guidance on indirect connections, go to:

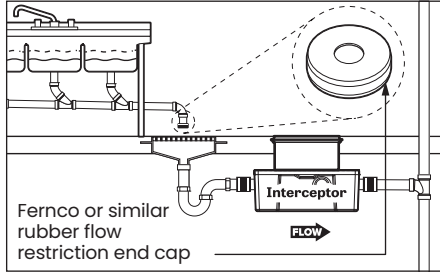

webtools.schierproducts.com/Technical_Data/Indirect_Connections.pdf

Flush-to-Grade Burials

Flush-to-Grade buried installations (without a riser) are not recommended for heavy foot traffic areas without the use of an internal gusset support kit **SGK2** (for GB2) or **SGK3** (for GB3).

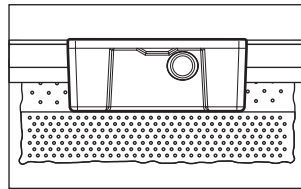

High Temperature Kitchen Water

If water is entering the interceptor at excessive temperature (over 140° F), a drain water tempering valve (DTV) and approved backflow prevention assembly must be installed. Most state and local plumbing codes prohibit water above 140° F being discharged into the sanitary sewer. Water above 140° F will weaken or deform PVC Schedule 40 pipe, poly drainage fixtures like interceptors and erode the coating of cast iron (leading to eventual failure).

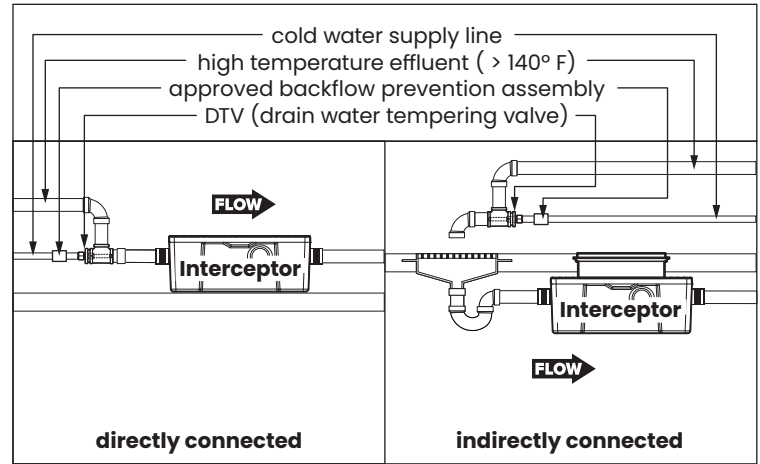

Fully Support Base of Unit

Install unit on solid, level surface in contact with the entire footprint of unit base; for suspended installations design trapeze to support the wet weight of the unit. Do not partially support unit or suspend unit using metal U-channel to create a trapeze

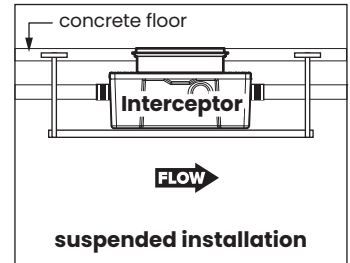

Support Inlet and Outlet Piping

For above grade installations ensure heavy inlet and outlet piping (such as cast iron or long runs) is properly supported or suspended during the entire installation process to prevent connection failure or damage to bulkhead fittings.

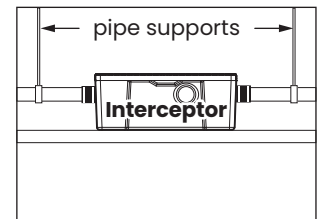

GETTING TO KNOW THE GBI-CT

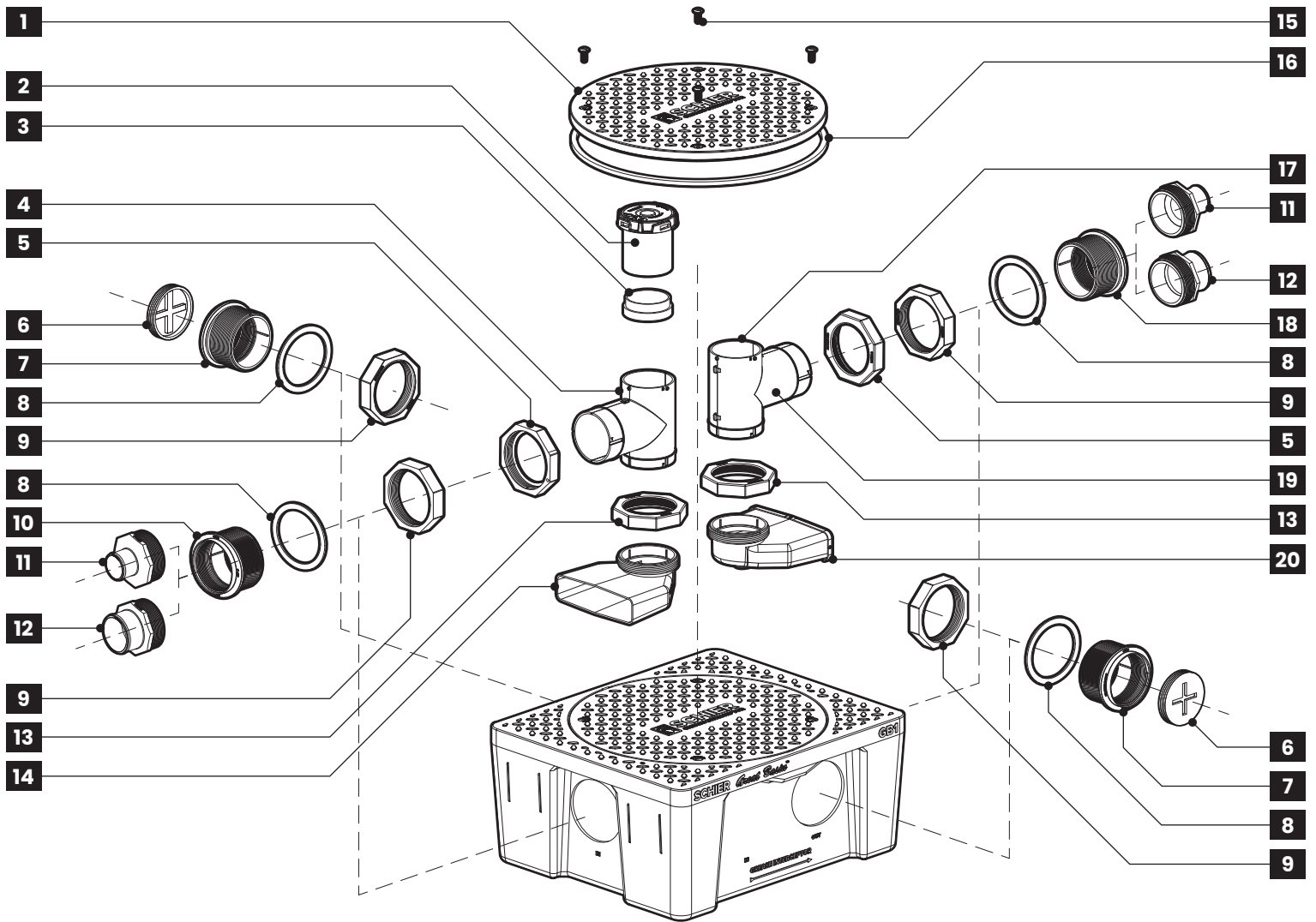

1. Cover
2. Standard Installation Flow Control Cartridge
3. 15 GPM Flow Control Extension (>5' below kitchen only)
4. Inlet Diffuser (Top)
5. Diffuser Retaining Nuts (x2)
6. 4" Cleanout Plugs (x2)
7. Optional Side Outlets 4" FPT (x2)

8. Connection Fitting Gaskets (x4)
9. Bulkhead Connection Retaining Nuts (x4)
10. Inlet 4" FPT Connection
11. 2" Plain End Fittings (x2)
12. 3" Plain End Fittings (x2)
13. Diffuser Foot Retaining Nuts (x2)
14. Inlet Diffuser (Foot)

15. Cover Bolts (x4)
16. Cover Gasket
17. Air Relief/Visual Access
18. Outlet 4" FPT Connection
19. Outlet Diffuser (Top)
20. Outlet Diffuser (Foot)

ON THE FLOOR INSTALLATION

Special Precautions

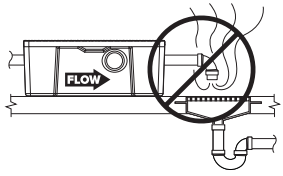
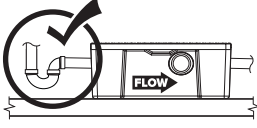
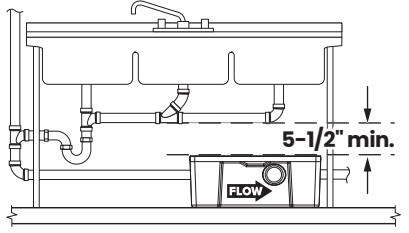
<p>1 ODOR ALERT! Do not install air gap on outlet side of interceptor.</p> 	<p>3 ODOR ALERT! Interceptor is not a sewer gas trap. All upstream fixtures must be trapped.</p> 	<p>4 Provide at least 5-1/2" clearance above unit for routine maintenance.</p> 
<p>2 Install interceptor as close as possible to fixtures being served</p>		

1 Test Tank for Water Tightness

1a Cap all connection points with 4" cleanout plugs using pipe thread sealant or tape approved for use with plastics.

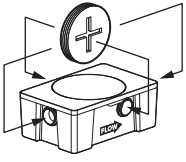

1b Remove cover and fill with water to just above the highest connection. For riser system testing (if required) fill to finished grade level. **CAUTION:** Support risers before filling to prevent tipping. Inspect unit, connections and gaskets for leaks. Check water level at specific time intervals per local code.

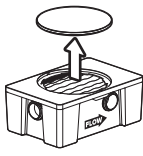

Leak?
Call customer care at 913-951-3300
8a - 5p M - F CST

2 Set Up Outlet Diffuser and Install Cleanout Plugs

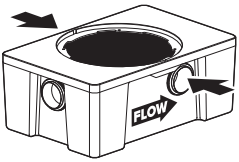
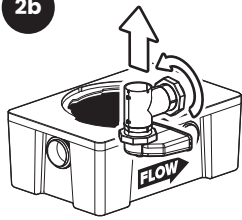
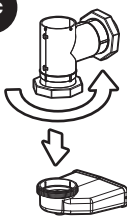
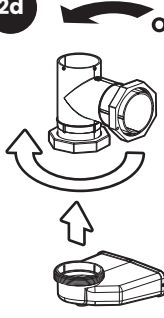
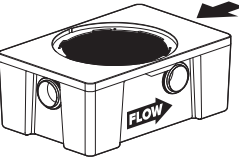
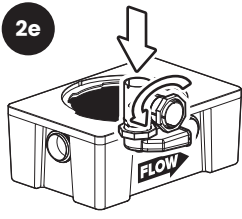
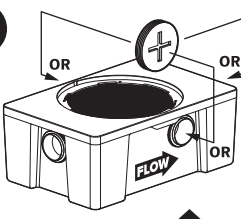
<p>2a Choose outlet location.</p>  <p>Side outlet</p>	<p>2b</p>  <p>Unscrew diffuser retaining nut and remove outlet diffuser.</p>	<p>2c</p>  <p>Unscrew diffuser foot retaining nut and remove outlet diffuser foot.</p>	<p>2d</p>  <p>OR</p> <p>Rotate diffuser toward chosen outlet, replace foot ensuring it will point to the back wall of the unit and hand tighten foot retaining nut.</p>
<p>OR</p>  <p>Straight-through</p>	<p>2e</p>  <p>Insert diffuser into chosen outlet and hand tighten retaining nut.</p>	<p>2f</p>  <p>OR</p>	<p>Cap all unused connection points with 4" cleanout plugs using pipe thread sealant or tape approved for use with plastics.</p>

ON THE FLOOR INSTALLATION

3 Calibrate Flow Control

Figure 1

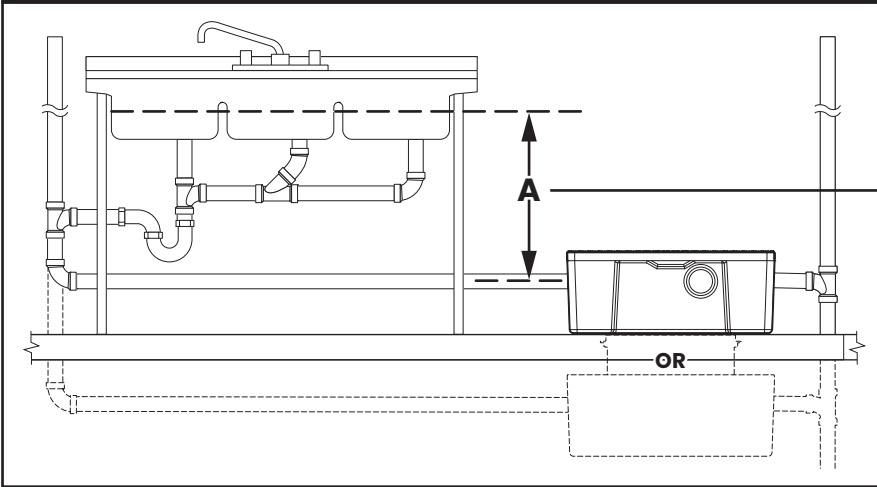

Note to Plumbing Inspector This interceptor includes certified internal flow control and does not require a dedicated "Flow Control Vent" (air intake).

- If dimension **A** is 5 feet or less **go to Step 4**.
- If dimension **A** is greater than 5 feet **follow Steps below**.

3a1

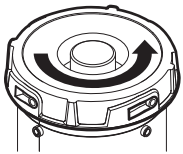

3a2

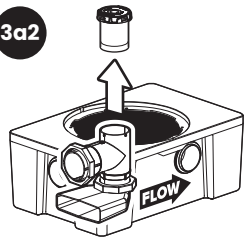

3b

Attach the 15 GPM Flow Control Cartridge Extension using PVC primer/cement. **Make sure extension is fully inserted into the cartridge and hold both components firmly together (until cement grabs) to prevent push-out.**

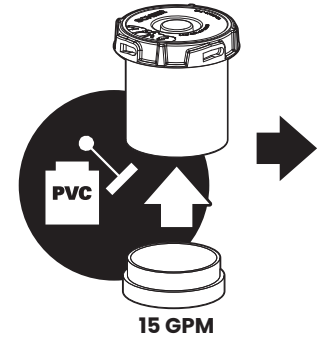

Rotate flow control cartridge counter-clockwise to release and remove from inlet diffuser

3c1

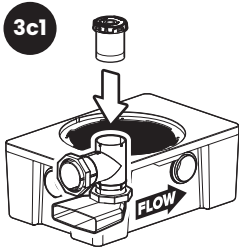

3c2

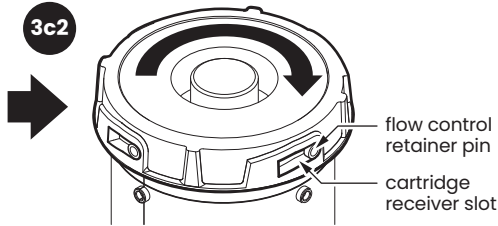

Slide flow control cartridge into top of inlet diffuser and rotate clockwise until cartridge drops onto flow control retainer pins. Continue rotating clockwise until pins are fully seated.

ON THE FLOOR INSTALLATION

4 Connect Piping

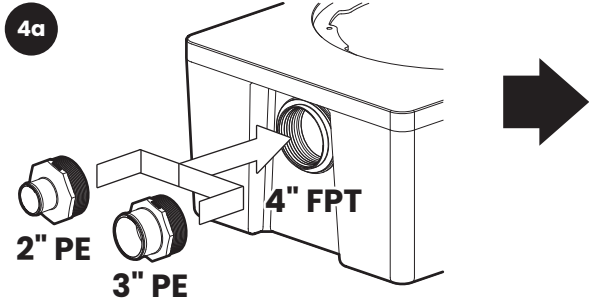

Choose inlet and outlet fittings (included) based on pipe size.

4b Connect piping using pipe thread sealant or tape approved for use with plastics. Ensure all upstream fixtures are trapped. **Vent per local code.**

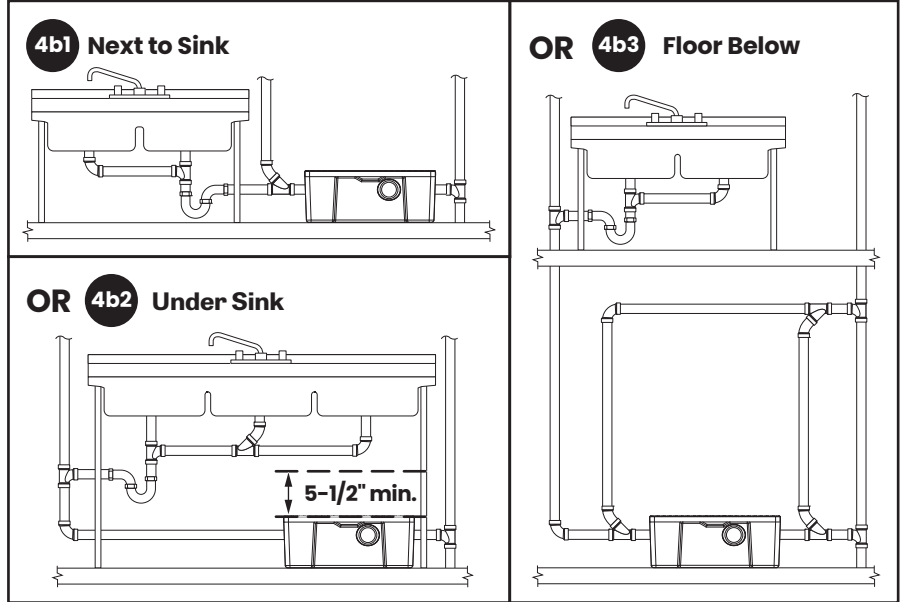

5 Wet or Air Test Piping Per Local Code

1 **WARNING!** DO NOT AIR TEST UNIT OR RISER SYSTEM!
Doing so may result in property damage, personal injury or death.



Leak? Call customer care at
913-951-3300
8a – 5p M – F CST

BURIED INSTALLATION

Special Precautions

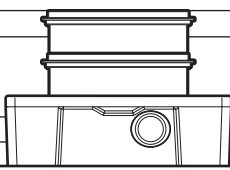
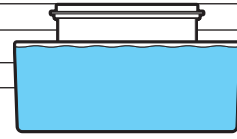
1 Install interceptor as close as possible to fixtures being served	2 2 Risers (25") Max 	3 Max Water Level Risers are not designed to retain water 
---	--	---

1 Test Tank for Water Tightness

1a Cap all connection points with 4" cleanout plugs using pipe thread sealant or tape approved for use with plastics.

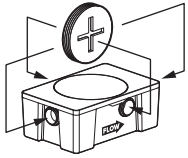

1b Remove cover and fill with water to just above the highest connection. For riser system testing (if required) fill to finished grade level. **CAUTION:** Support risers before filling to prevent tipping. Inspect unit, connections and gaskets for leaks. Check water level at specific time intervals per local code.

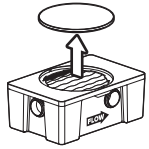

Leak?
Call customer care at 913-951-3300
8a - 5p M - F CST

2 Set Up Outlet Diffuser and Install Cleanout Plugs

2a Choose outlet location.

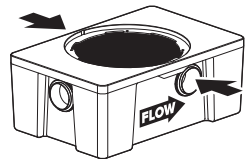

Side outlet

OR

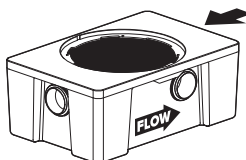

Straight-through

2b Unscrew diffuser retaining nut and remove outlet diffuser.

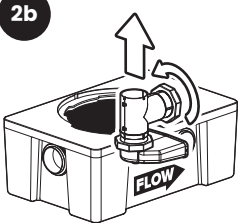

2c Unscrew diffuser foot retaining nut and remove outlet diffuser foot.

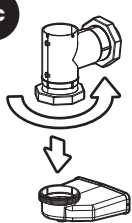

2d Rotate diffuser toward chosen outlet, replace foot ensuring it will point to the back wall of the unit and hand tighten foot retaining nut.

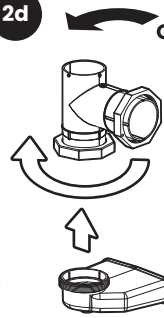

2e Insert diffuser into chosen outlet and hand tighten retaining nut.

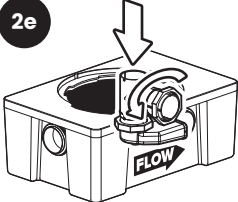

2f Cap all unused connection points with 4" cleanout plugs using pipe thread sealant or tape approved for use with plastics.

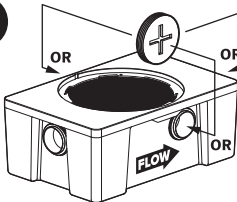

BURIED INSTALLATION

3 Calibrate Flow Control

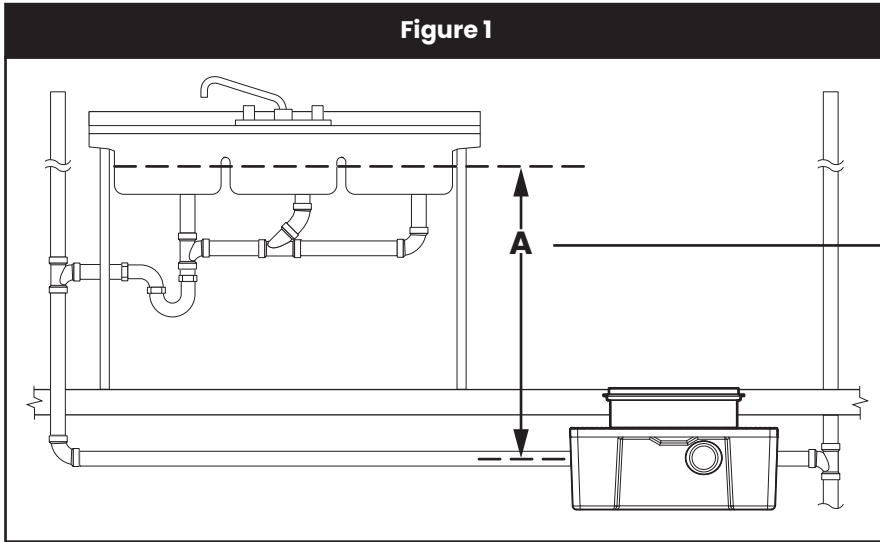

Note to Plumbing Inspector This interceptor includes certified internal flow control and does not require a dedicated "Flow Control Vent" (air intake).

- If dimension **A** is 5 feet or less **go to Step 4.**
- If dimension **A** is greater than 5 feet **follow Steps below.**

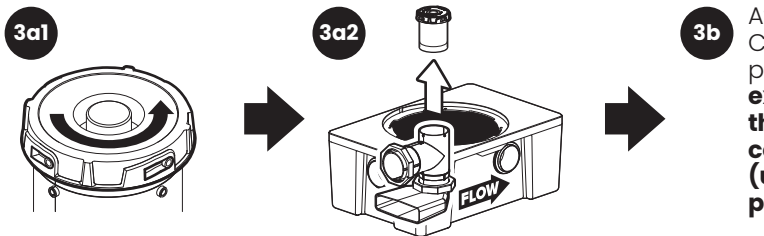

Attach the 15 GPM Flow Control Cartridge Extension using PVC primer/cement. **Make sure extension is fully inserted into the cartridge and hold both components firmly together (until cement grabs) to prevent push-out.**

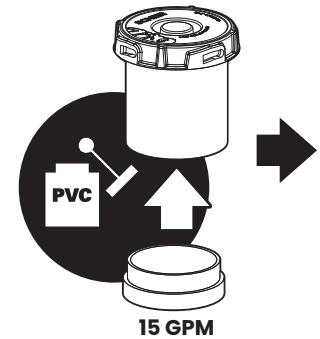

Rotate flow control cartridge counter-clockwise to release and remove from inlet diffuser

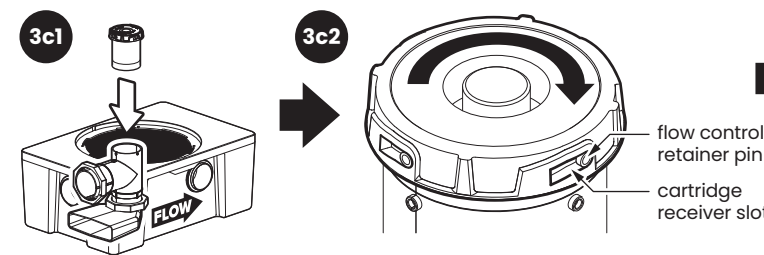

Slide flow control cartridge into top of inlet diffuser and rotate clockwise until cartridge drops onto flow control retainer pins. Continue rotating clockwise until pins are fully seated.

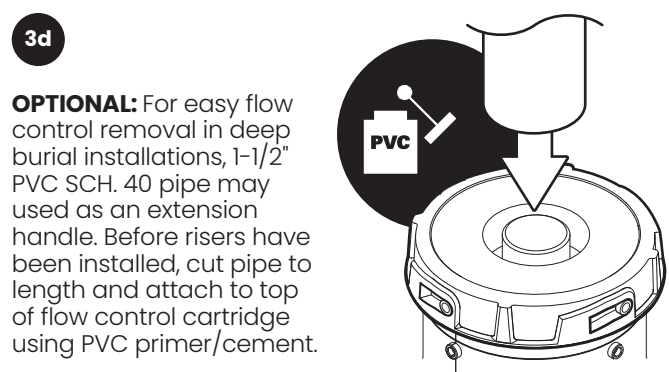

4 Excavation

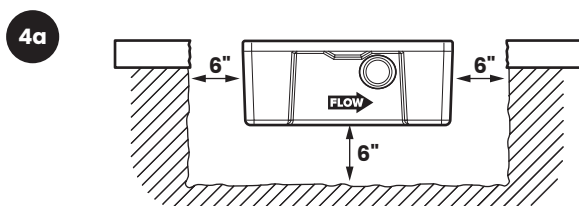

Excavate hole 6" larger than interceptor on all sides.

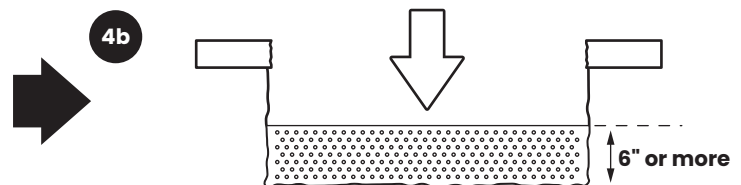

Add crushed aggregate (approximately 3/4" size rock or sand, with no fines) to base of hole.

BURIED INSTALLATION

5 Connect Piping

⚠ Floor Sink Installation

If your dishwashing sink(s) discharges into a floor drain/sink (drain), you must regulate the flow into the drain to avoid an overflow of water onto the kitchen floor. This can be done by installing a valve or flow restriction cap on the sink piping that discharges into the drain.

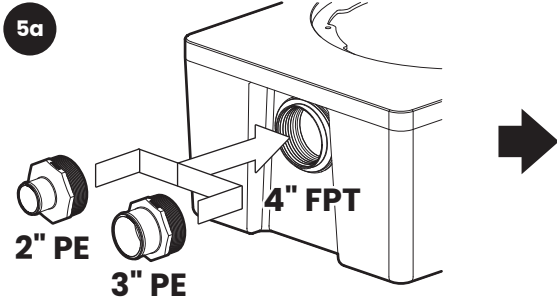
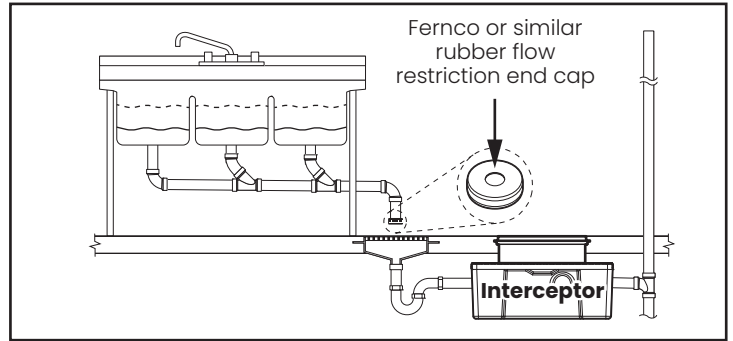

Choose inlet and outlet fittings (included) based on pipe size.

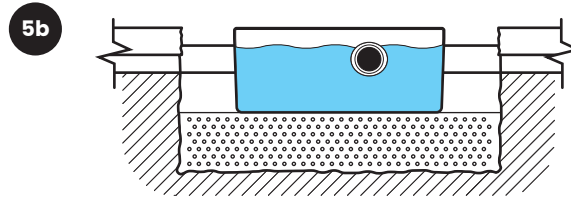

Set interceptor and connect piping using pipe thread sealant or tape approved for use with plastics. **Vent per local code.** Fill tank with water so that it remains in place during backfill.

6 Wet or Air Test Piping Per Local Code

⚠ WARNING! DO NOT AIR TEST UNIT OR RISER SYSTEM!
Doing so may result in property damage, personal injury or death.

Leak? Call customer care at 913-951-3300
8a – 5p M – F CST

7 Backfill and Finished Grade

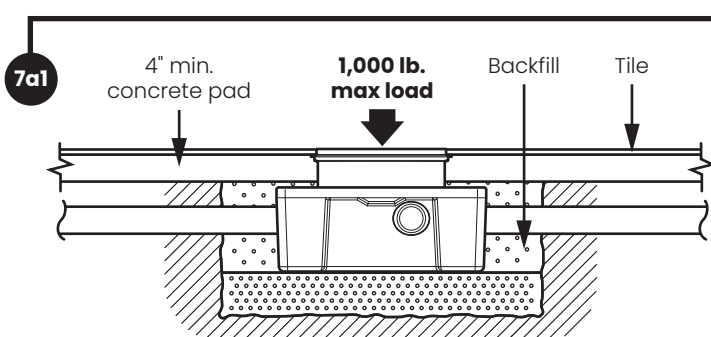

Below Grade with Riser (preferred): See instructions included with FCRI riser. Backfill evenly around tank using crushed aggregate (approximately 3/4" size rock or sand, with no fines), finish with a minimum 4" thick concrete pad.

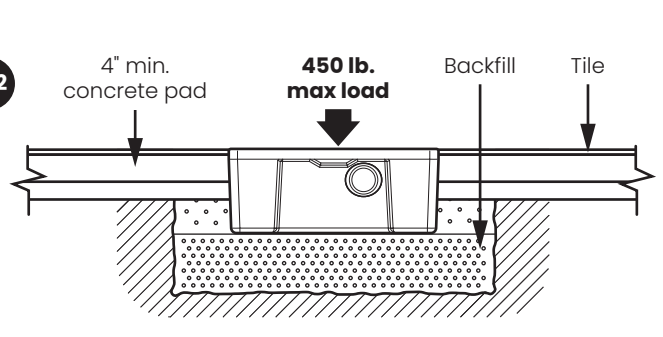

Flush-to-Grade Burials: Not recommended for heavy foot traffic areas. Backfill evenly around tank using crushed aggregate (approximately 3/4" size rock or sand, with no fines), finish with a minimum 4" thick concrete pad.