

Gas Valve Replacement Kit



Kit Part Number: PTRKIT111

Parts List

1. Honeywell Gas Valve VK4115V (120V)
2. Gas Valve/Orifice Gasket
3. Torex Screws (3 pcs)
4. Venturi/Blower Housing Gasket
5. # 25 Torex Wrench.

Recommended tools:

- A. Pipe Wrench.
- B. Phillips Screw Driver.
- C. Flat Blade Putty Knife.
- D. # 25 Torex Wrench. (Furnished in Kit.)

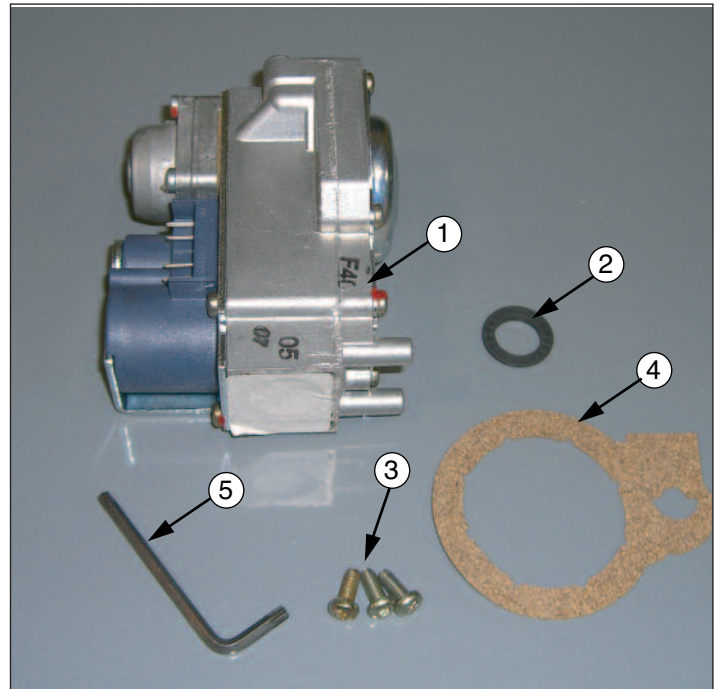

! WARNING

Indicates a potentially hazardous situation which, if ignored, can result in serious injury or substantial property damage.

NOTICE

Indicates special instructions on installation, operation or maintenance, which are important to equipment but not related to personal injury hazards.

! WARNING

Failure to follow instructions below can result in severe personal injury or damage if ignored.

- Instructions are for a qualified installer/service technician.
- Read all instructions before proceeding.
- Follow instructions in proper order.

NOTICE

This kit is designed for gas valve replacement on the Prestige TriMax 60, 110, 175, 250 and Prestige TriMax Excellence products. Boiler serial number must start with PT.

! WARNING

For your safety, turn off electrical power supply at service panel before proceeding to avoid possible electrical shock hazard. Failure to do so can cause severe personal injury or death.

NOTICE

This kit **MUST NOT** be used on Prestige Boilers equipped with MCBA Controls. These boilers have a serial number starting with PS.

Gas Valve Replacement Kit

PRESTIGE BOILER INSTRUCTIONS:

1. Turn power to the unit "OFF".
2. Shut off the gas supply to the boiler at the main manual shutoff valve.
3. Remove the front jacket panel.
4. Remove the air inlet elbow from the venturi.
5. Remove the Molex plug from the gas valve.
6. Disconnect the gas supply piping inside the PRESTIGE at the brass union located just before the gas valve.

7. Remove and save the two Torex screws attaching the venturi / gas valve assembly from the blower housing. See Fig.1. Remove the venturi / gas valve assembly from the blower housing. Use the Torex wrench supplied in the kit to remove screws.

NOTICE

There is a gasket between the venturi and blower housing. If gasket "sticks" to the blower housing use a flat blade putty knife to remove any gasket material. Make sure not to scratch or score the mating surface on the blower housing.

8. Remove the three screws attaching the gas valve to the venturi. Use Torex wrench supplied in kit to remove screws. Note orientation of the venturi to the old gas valve for reassembly of the venturi on the new gas valve.
9. Reassemble the new gas valve, gas valve/orifice gasket and the three Torex screws from the kit and reassemble the gas valve to the venturi. See Fig. 2.

WARNING

Ensure the gas valve/orifice gasket is in place before reassembling the gas valve and venturi. Failure to do so can result in death, serious injury or substantial property damage.

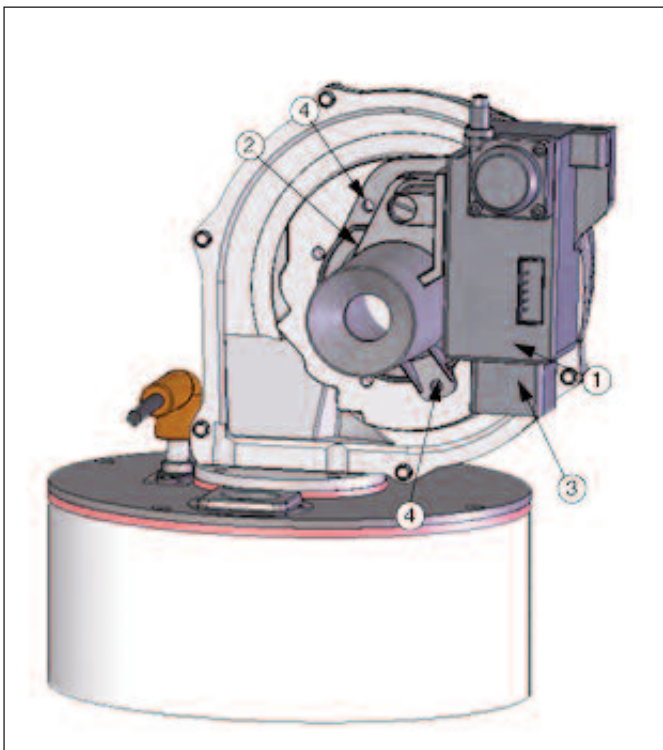

1. Gas Valve
 2. Venturi
 3. Gas Valve Fitting
 4. Venturi Mounting screws.
- Attaching Gas Valve/Venturi to Blower Housing

Fig. 1: Prestige Burner Assembly

Gas Valve Replacement Kit

NOTICE

For propane installations a brass orifice is located inside the gas valve/orifice gasket. This orifice must be placed inside of the new gas valve/orifice gasket before reassembly.

⚠ WARNING

Failure to insert the propane brass orifice, on propane installations, before reassembling the gas valve and venturi can result in the production of carbon monoxide due to incomplete combustion and may result in death, serious injury or substantial property damage.

10. With the venturi to blower gasket in place, reassemble the venturi / gas valve to the blower housing using the two mounting screws from step 7.

NOTICE

For the reassembly process do not use adhesive on any gasket surface.

11. Reconnect the Molex plug to the gas valve electrical connection.
12. Reconnect the brass gas piping union connection. Open the main manual gas shutoff valve before placing the PRESTIGE unit back into operation check and test all gas connections for leaks. Repair leaks if found.

⚠ WARNING

Do not check for gas leaks with an open flame. Use a bubble test. Failure to check for gas leaks can cause severe personal injury, death or substantial property damage.

13. Reattach the air inlet elbow to the venturi.
14. Reattach the front jacket panel.
15. Turn the electrical power “ON” to the PRESTIGE to return the unit back into service.

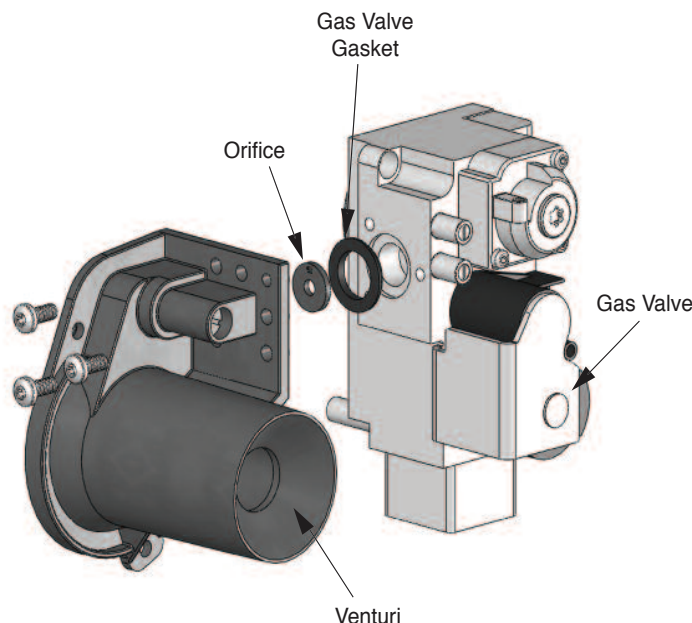

Fig. 2: Gas Valve / Venturi Assembly - PRESTIGE Solo 60/110/175/250

Gas Valve Replacement Kit

COMBUSTION TEST

1. The installer **MUST** perform a complete combustion check to ensure the following combustion levels are met at high and low input firing rates and the burner is operating at optimum conditions.

Table 1: Combustion Settings

	Natural Gas	Propane
O2 Min.	2.30%	2.70%
O2 Max.	5.30%	4.70%
CO2 Min.	8.80%	10.70%
CO2 Max.	10.50%	12.00%
CO Max.	100 ppm	100 ppm

WARNING

The combustion testing and adjustments must be performed by a qualified installer, service agency or the gas supplier. All combustion measurements must be performed with calibrated equipment to ensure proper readings and accuracy.

WARNING

Failure to perform a complete combustion test at both high and low input rates may result in incomplete combustion and the production of carbon monoxide, which can cause severe personal injury, death or substantial property damage.

2. Test for CO₂ or O₂ and for CO during high firing rate. The combustion readings should be within the range listed in Table 1. **The CO level should not exceed 100 ppm when combustion is correct.** Perform the following procedure to manually place the burner into high fire.
 - a. Press the round INSTALLER button. See Fig. 3.

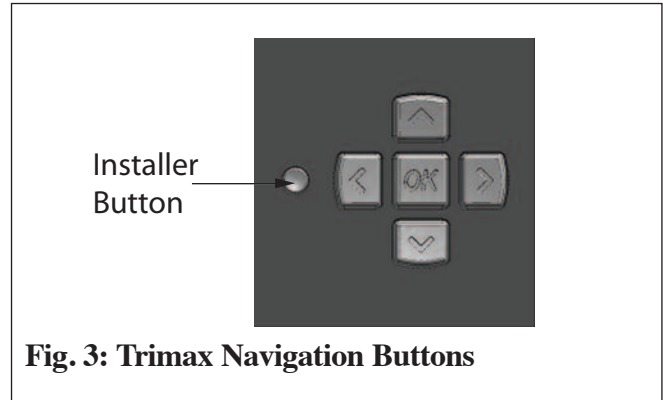

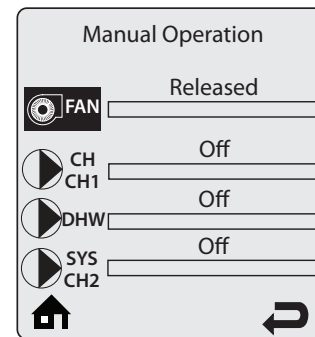

Fig. 3: Trimax Navigation Buttons

- b. Enter the installer access code “054” by using the **LEFT** and **RIGHT** buttons to select a digit and the **UP** and **DOWN** buttons to change the digit. Press the **OK** button to enter the access code.
- c. Press the **RIGHT** button to highlight the Manual Operation icon  then press the **OK** button.
- d. Press the OK button while the FAN icon is highlighted to manually fire the burner and power the CH circulator.



NOTICE

An adequate CH load must be present to dissipate the heat generated during the combustion test. If an adequate CH load is not available, an indirect water heater can be used to dissipate the heat by creating a DHW call which will enable the DHW circulator.

- e. Press the **LEFT** and **RIGHT** buttons to adjust the firing rate from 0% to 100%. Hold down the **LEFT** or **RIGHT** button to rapidly increase or decrease the firing rate.

Gas Valve Replacement Kit

- f. Press the **OK** button while the FAN icon is highlighted to shutdown the burner.
- g. Cycle power to the Prestige once combustion testing is complete to return to normal operation.

⚠ WARNING

The combustion levels should be measured at high firing rate. If the combustion levels are not within the range given in Table 1 for the firing rate, shut the boiler down and contact Triangle Tube Engineering Department. Failure to comply with this requirement could result in severe personal injury, death or substantial property damage.

If the combustion levels during high fire is outside the recommended combustion settings adjust the **THROTTLE SCREW** (see Fig. 4) as follows:

Counter-clockwise adjustment of the throttle screw at high fire:

O₂ decreases and CO₂ increases

Clockwise adjustment of the throttle screw at high fire:

O₂ increases and CO₂ decreases

- 4. Once the combustion level is set at high fire, manually place the boiler into low fire mode by pressing the **LEFT** button to adjust firing rate down.
- 5. If the combustion level during low fire is not within $\pm 0.2\%$ of the combustion level measured at high fire, adjust the metal offset screw inside the brass fitting on the top right of the gas valve (see Fig. 4) as follows.

Counter-clockwise adjustment of offset screw at low fire:

O₂ increases and CO₂ decreases

Clockwise adjustment of offset screw at low fire:

O₂ decreases and CO₂ increases

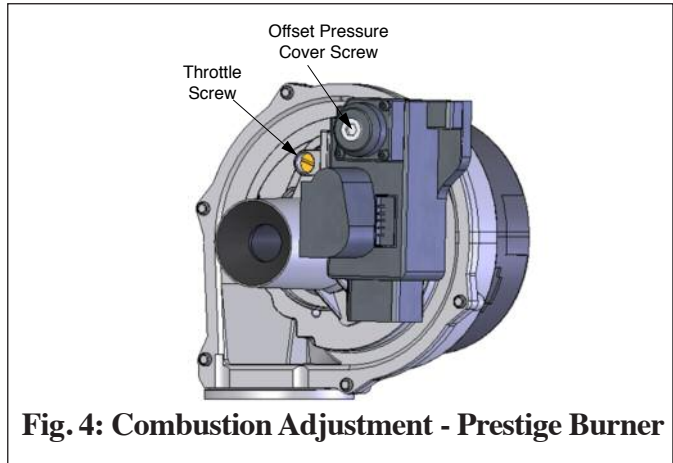

Fig. 4: Combustion Adjustment - Prestige Burner